

# Operator's Manual

# CRAFTSMAN®

## 10 in. SLIDING COMPOUND MITER SAW WITH LASER TRAC® Model No. 137.212370

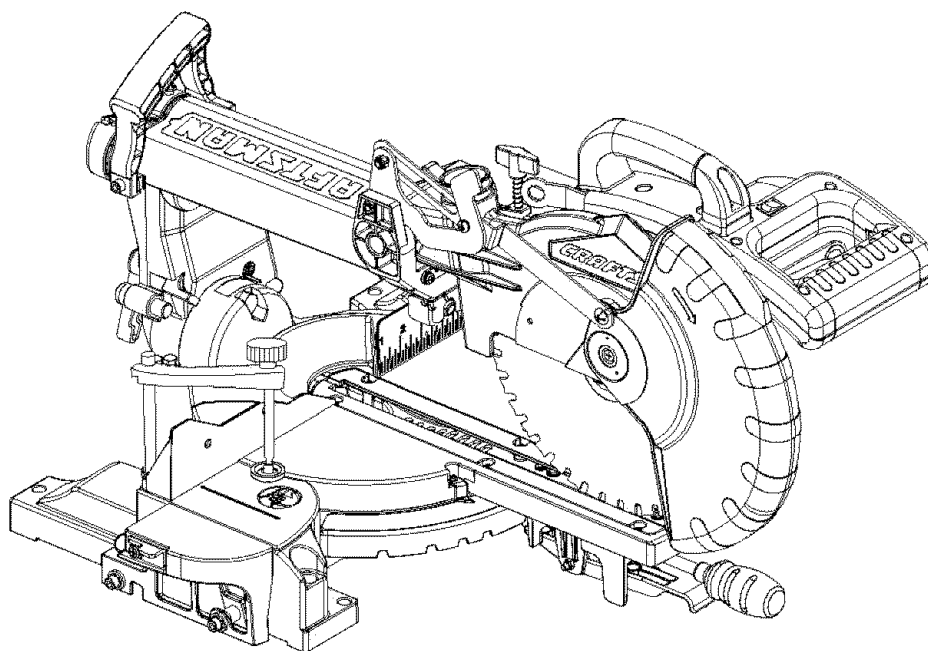

### CAUTION:

Before using this Miter Saw, read this manual and follow all its Safety Rules and Operating Instructions

- Safety Instructions
- Installation
- Operation
- Maintenance
- Parts List

**Customer Help Line  
For Technical Support  
1-800-843-1682**

**Sears Parts &  
Repair Center  
1-800-488-1222**

Sears, Roebuck and Co., Hoffman Estates, IL 60179 USA

Visit our Craftsman website: [www.sears.com/craftsman](http://www.sears.com/craftsman)

Part No. 137212370001

# TABLE OF CONTENTS

SECTION	PAGE	SECTION	PAGE
Warranty .....	2	Know Your Sliding Compound Miter Saw .....	8
Product Specifications .....	2	Glossary of Terms .....	9
Power Tool Safety .....	3	Assembly .....	10
Sliding Compound Miter Saw Safety .....	4	Adjustments .....	14
Electrical Requirements and Safety .....	4	Operation .....	16
Accessories and Attachments .....	6	Maintenance .....	24
Tools Needed for Assembly .....	6	Troubleshooting Guide .....	25
Carton Contents .....	7	Parts List .....	26

## WARRANTY

### ONE-YEAR FULL WARRANTY ON CRAFTSMAN TOOL

If this Craftsman tool fails due to a defect in material or workmanship within one year from the date of purchase, **CALL 1-800-4-MY-HOME® TO ARRANGE FOR FREE REPAIR** (or replacement if repair proves impossible). If this tool is used for commercial or rental purposes, this warranty will apply for only ninety days from the date of purchase. This warranty applies only while this tool is in the United States. This warranty gives you specific legal rights, and you may also have other rights, which vary, from state to state.

**Sears, Roebuck and Co., Hoffman Estates, IL 60179**

#### WARNING

Some dust created by power sanding, sawing, grinding, drilling and other construction activities contains chemicals known to cause cancer, birth defects or other reproductive harm. Some examples of these chemicals are:

- Lead from lead-based paints
- Crystalline silica from bricks, cement and other masonry products
- Arsenic and chromium from chemically treated lumber

Your risk from these exposures varies, depending on how often you do this type of work. To reduce your exposure to these chemicals, work in a well ventilated area and work with approved safety equipment such as dust masks that are specially designed to filter out microscopic particles.

## PRODUCT SPECIFICATIONS

#### MOTOR

Power Source ..... 120V AC, 60Hz, 15 Amp  
 Arbor Shaft Size ..... 5/8 in.  
 Speed ..... 4800 RPM (No load)  
 Brake ..... Electric  
 Double Insulated ..... Yes

#### MITER SAW

##### Rotating Table:

Miter Detent Stops ..... 0°, 15°, 22.5°, 31.6°, 45° R & L  
 Bevel Positive Stops ..... 0°, 33.9°, 45° L  
 Extension Wings ..... Yes

#### MITER SAW

##### Cutting Capacity:

Crosscut ..... 3-5/8 in. x 12 in.  
 Miter 45° R. & L ..... 3-5/8 in. x 8 in.  
 Bevel 45° L ..... 1-5/8 in. x 12 in.  
 45° Miter and 45° Bevel ..... 1-5/8 in. x 8 in.

#### BLADE

Diameter ..... 10 in.  
 Arbor ..... 5/8 in.

#### WARNING

To avoid electrical hazards, fire hazards or damage to the tool, use proper circuit protection.

This tool is wired at the factory for 110-120 Volt operation. It must be connected to a 110-120 Volt / 15 Ampere time delay fuse or circuit breaker. To avoid shock or fire, replace power cord immediately if it is worn, cut or damaged in any way.

Before using your tool, it is critical that you read and understand these safety rules. Failure to follow these rules could result in serious injury to you or damage to the tool.

# POWER TOOL SAFETY

## GENERAL SAFETY INSTRUCTIONS

Read and understand all the instructions below before using the power tool. These safety instructions are not meant to cover every possible condition that could occur. As with any power tool, common sense, vigilance and due care must be used.

1. **READ** and become familiar with the entire Operator's Manual. **LEARN** the tool's application, limitations and possible hazards.
2. **KEEP GUARDS IN PLACE** and in working order.
3. **REMOVE ADJUSTING KEYS AND WRENCHES.** Form the habit of checking to see that keys and adjusting wrenches are removed from the tool before turning ON.
4. **KEEP WORK AREA CLEAN.** Cluttered areas and benches invite accidents.
5. **DO NOT USE IN DANGEROUS ENVIRONMENTS.** Do not use power tools in damp locations or expose them to rain or snow. Keep work area well lit.
6. **KEEP CHILDREN AWAY.** All visitors and bystanders should be kept at a safe distance from work area.
7. **MAKE WORKSHOP CHILDPROOF** with padlocks, master switches or by removing starter keys.
8. **DO NOT FORCE THE TOOL.** It will do the job better and is safer if used at the rate for which it was designed.
9. **USE THE RIGHT TOOL.** Do not force the tool or an attachment to do a job for which it was not designed.
10. **USE PROPER EXTENSION CORDS.** Make sure your extension cord is in good condition. When using an extension cord, be sure to use one heavy enough to carry the current your product will draw. An undersized cord will result in a drop in line voltage and in loss of power that will cause the tool to overheat. The table on page 5 shows the correct size to use depending on cord length and nameplate ampere rating. If in doubt, use the next heavier gauge. The smaller the gauge number, the heavier the cord.
11. **WEAR PROPER APPAREL.** Do not wear loose clothing, gloves, neckties, rings, bracelets or other jewelry that may get caught in moving parts. Non-slip footwear is recommended. Wear protective hair covering to contain long hair.
12. **ALWAYS WEAR EYE PROTECTION.** Any power tool can throw debris into the eyes and could cause permanent eye damage. ALWAYS wear Safety Goggles (not glasses) that comply with ANSI Safety standard Z87.1. Everyday eyeglasses have only impact-resistant lenses. They **ARE NOT** safety glasses. **NOTE:** Glasses or goggles not in compliance with ANSI Z87.1 could cause serious injury.
13. **WEAR A FACE MASK OR DUST MASK.** Sawing operation produces dust.
14. **SECURE WORK.** Use clamps or a vise to hold work when practical. It's safer than using your hand, and it frees both hands to operate the tool.
15. **DISCONNECT TOOLS FROM POWER SOURCE** before servicing and when changing accessories, such as blades, bits and cutters.
16. **REDUCE THE RISK OF UNINTENTIONAL STARTING.** Make sure switch is in the OFF position before plugging in the tool.
17. **USE RECOMMENDED ACCESSORIES.** Consult this Operator's Manual for recommended accessories. The use of improper accessories may cause injury to yourself or others.
18. **NEVER STAND ON THE TOOL.** Serious injury could occur if the tool is tipped or if the cutting tool is unintentionally contacted.
19. **CHECK FOR DAMAGED PARTS.** Check for alignment of moving parts, binding of moving parts, breakage of parts, mounting and any other conditions that may affect its operation. A guard or other part that is damaged should be properly repaired or replaced.
20. **NEVER LEAVE THE TOOL RUNNING UNATTENDED. TURN THE POWER OFF.** Do not walk away from a running tool until the blade comes to a complete stop, and then unplug the unit.
21. **DO NOT OVERREACH.** Keep proper footing and balance at all times.
22. **MAINTAIN TOOLS WITH CARE.** Keep tools sharp and clean for best and safest performance. Follow instructions for lubricating and changing accessories.
23. **DIRECTION OF FEED.** Feed work into a blade or cutter against the direction or rotation of the blade or cutter.
24. **WARNING:** Dust generated from certain materials can be hazardous to your health. Always operate the saw in a well-ventilated area and provide for proper dust removal.
25. **DO NOT** loan your tool to another person without providing him/her with the Operator's Manual. Be sure he /she learns the tools applications and possible hazards.

# SLIDE COMPOUND MITER SAW SAFETY

- IMPORTANT: DO NOT USE THIN KERF BLADES.** They can deflect and contact the blade guard and cause possible injury to the operator.
- DO NOT** operate the miter saw until it is completely assembled and installed according to these instructions.
- IF YOU ARE NOT** thoroughly familiar with the operation of miter saws, seek guidance from your supervisor, instructor or other qualified person.
- ALWAYS** hold the work firmly against the fence and table. **DO NOT** perform any operation freehand (use clamp wherever possible).
- KEEP HANDS** out of the path of the saw blade. If the workpiece you are cutting would cause your hands to be within 7-1/2 in. of the saw blade, the workpiece should be clamped in place before making the cut.
- MAKE SURE** the blade is sharp, runs freely and is free of vibration.
- ALLOW** the motor to come up to full speed before starting a cut.
- KEEP THE MOTOR AIR SLOTS CLEAN** and free of chips or dust.
- ALWAYS MAKE SURE** all handles are tight before cutting, even if the table is positioned in one of the positive stops.
- MAKE SURE** both the blade and the collar are clean and the arbor bolt is tightened securely.
- USE** only blade collars specified for your saw.
- NEVER** use blades larger than 10 in. in diameter.
- NEVER** apply lubricants to the blade when the saw is running.
- ALWAYS** check the blade for cracks or damage before operation. Replace a cracked or damaged blade immediately.
- NEVER** use blades recommended for operation at less than 4800 rpm.
- ALWAYS** keep the blade guards in place and use at all times.
- NEVER** reach around the saw blade.
- MAKE SURE** the blade is not in contact with the workpiece before the switch is turned ON.
- IMPORTANT:** After completing a cut, release the trigger switch and wait for the blade to stop before returning the saw to the raised position.
- MAKE SURE** the blade has come to a complete stop before removing or securing the workpiece, changing the workpiece angle or changing the angle of the blade.
- NEVER** cut metals or masonry products with this tool. This miter saw is designed for use on wood and wood-like products.
- NEVER** cut small pieces. If the workpiece being cut would cause your hand or fingers to be within 7-1/2 in. of the saw blade, the workpiece is too small.
- PROVIDE** adequate support to the sides of the saw table for long workpieces.
- NEVER** use the miter saw in areas with flammable liquids or gases.
- NEVER** use solvents to clean plastic parts. Solvents could possibly dissolve or otherwise damage the material.
- SHUT OFF** the power before servicing or adjusting the tool.
- DISCONNECT** the saw from the power source and clean the machine when finished using.
- MAKE SURE** the work area is clean before leaving the machine.
- SHOULD** any part of your miter saw become missing, damaged, fail in any way or any electrical component fail to perform properly, shut off the switch and remove the plug from the power supply outlet. Replace missing, damaged or failed parts before resuming operation.

## ELECTRICAL REQUIREMENTS

### WARNING

#### POWER SUPPLY AND MOTOR SPECIFICATIONS

The AC motor used in this saw is a universal, nonreversible type. See "MOTOR" in the "PRODUCT SPECIFICATIONS" section on page 2.

To avoid electrical hazards, fire hazards or damage to the tool, use proper circuit protection. Your saw is wired at the factory for 120 V operation. Connect to a 120 V circuit. This circuit must not be less than a #12 wire with a 20 A time-lag fuse or a #14 wire with a 15 A time-lag fuse. To avoid shock or fire, if power cord is worn or cut, or damaged in any way, have it replaced immediately.

# ELECTRICAL REQUIREMENTS AND SAFETY

## ELECTRICAL REQUIREMENTS – cont'd DOUBLE INSULATED

The power tool is double insulated to provide a double thickness of insulation between you and tool's electrical system. All exposed metal parts are isolated from the internal metal motor components with protecting insulation.

**Replacement parts** – When servicing use only identical replacement parts.

**Polarized plugs** – This saw has a plug that looks like the one shown below:

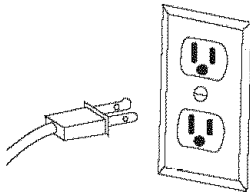

To reduce the risk of electrical shock, this saw has a polarized plug (one blade is wider than the other). This plug will fit in a polarized outlet only one way. If the plug does not fit fully in the outlet, reverse the plug. If it still does not fit, contact a qualified electrician to install the proper outlet. Do not change the plug in any way.

### WARNING

**Double insulation does not take the place of normal safety precautions when operating this tool. To avoid electrocution:**

1. Use only identical replacement parts when servicing a tool with double insulation. Servicing should be performed by a qualified technician.
2. Do not use power tools in wet or damp locations or expose them to rain or snow.

## MOTOR SAFETY PROTECTION IMPORTANT:

To avoid motor damage, the motor should be blown out or vacuumed frequently to keep sawdust from interfering with the motor ventilation.

1. **CONNECT** this saw to a 120 V, 15 A circuit with a 15 A time-delay fuse or circuit breaker. Using the wrong size fuse can damage the motor.
2. If the motor won't start, release the trigger switch immediately. **UNPLUG THE SAW.** Check the saw blade to make sure it turns freely. If the blade is free, try to start the saw again. If the motor still does not start, refer to the **TROUBLESHOOTING GUIDE.**
3. If the tool suddenly stalls while cutting wood, release the trigger switch, unplug the tool, and free the blade from the wood. The saw may now be started and the cut finished.

4. **FUSES** may “blow” or circuit breakers may trip frequently if:
  - a. **MOTOR** is overloaded – overloading can occur if you feed too rapidly or make too many start/stops in a short time.
  - b. **LINE VOLTAGE** is more than 10% above or below the nameplate voltage rating. For heavy loads, the voltage at motor terminals must equal the voltage specified on the nameplate.
  - c. **IMPROPER** or dull saw blades are used.
5. Most motor troubles may be traced to loose or incorrect connections, overload, low voltage or inadequate power supply wiring. Always check the connections, the load and supply circuit if the motor doesn't run well. Check minimum gauge for the length of cord you are using on the chart below.

## GUIDELINES FOR EXTENSION CORDS

**Use a proper extension cord.** Make sure your extension cord is in good condition. When using an extension cord, be sure to use one heavy enough to carry the current your product will draw. An undersized cord will cause a drop in line voltage, resulting in loss of power and cause overheating. The table below shows the correct size to use depending on cord length and nameplate ampere rating. If in doubt, use the next heavier gauge. The smaller the gauge number, the heavier the cord.

**Be sure your extension cord is properly wired** and in good condition. Always replace a damaged extension cord or have it repaired by a qualified person before using it. Protect your extension cords from sharp objects, excessive heat and damp or wet areas.

**Use a separate electrical circuit for your tools.** This circuit must not be less than a #12 wire with a 20 A time-lag fuse or a #14 wire with a 15 A time-lag fuse. **NOTE:** When using an extension cord on a circuit with a # 14 wire, the extension cord must not exceed 25 feet in length. Before connecting the tool to the power line, make sure the switch is in the OFF position and the electric current is rated the same as the current stamped on the motor nameplate, running at a lower voltage will damage the motor.

MINIMUM GAUGE FOR EXTENSION CORDS (AWG)				
(When using 120 volts only)				
	Ampere Rating		Total length of Cord	
	More Than	Not More Than	25ft.	50ft. 100ft. 150ft.
0	6		18	16 16 14
6	10		18	16 14 12
10	12		16	16 14 12
12	16		14	12 Not Recommended

**CAUTION:** In all cases make certain the receptacle in question is properly grounded. If you are not sure, have a certified electrician check the receptacle.

## ACCESSORIES AND ATTACHMENTS

### RECOMMENDED ACCESSORIES

#### **▲ WARNING**

- Use only accessories recommended for this miter saw. Follow instructions that accompany accessories. Use of improper accessories may cause hazards.
- The use of any cutting tool except 10 inch saw blades which meet the requirements under recommended accessories is prohibited. Do not use accessories such as shaper cutters or dado sets. Ferrous metal cutting and the use of abrasive wheels is prohibited.
- Do not attempt to modify this tool or create accessories not recommended for use with this tool. Any such alteration or modification is misuse and could result in a hazardous condition leading to possible serious injury.

### ACCESSORIES

Visit your Sears Hardware Department or see the Sears Power and Hand Tool Catalog to purchase recommended accessories for this power tool.

#### **▲ WARNING**

To avoid the risk of personal injury, do not modify this power tool or use accessories not recommended by Sears.

#### **▲ WARNING**

Read warnings and conditions on your **CARBIDE TIPPED SAW BLADE**. Do not operate the saw without the proper saw blade guard in place. Carbide is a very hard but brittle material. Care should be taken while mounting, using and storing carbide tipped blades to prevent accidental damage. Slight shocks, such as striking the tip while handling, can seriously damage the blade. Foreign objects in the workpiece, such as wire or nails, can also cause tips to crack or break off. Before using, always visually examine the blade and tips for bent blade, cracks, breakage, missing or loose tips, or other damage. Do not use if damage is suspected. Failure to heed safety instructions and warnings can result in serious bodily injury.

## TOOLS NEEDED FOR ASSEMBLY

### Supplied

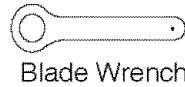

### Not supplied

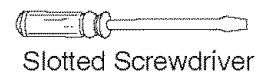
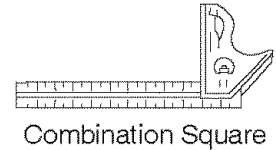
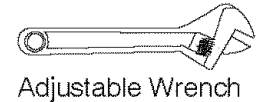

### COMBINATION SQUARE MUST BE TRUE

Should not gap or overlap when square is flipped over (see dotted figure).

Draw light line on board along this edge.

Straight edge or a 3/4 in. board, this edge must be perfectly straight.

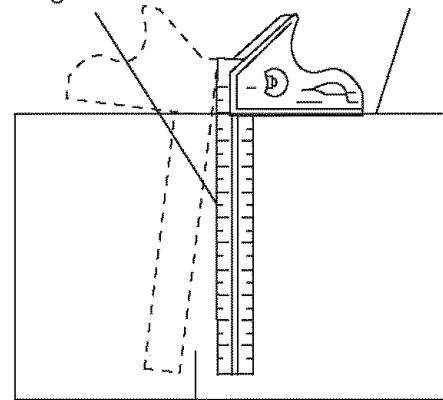

Gap from untrue square when flipped over.

# CARTON CONTENTS

## UNPACKING YOUR MITER SAW

### **▲ WARNING**

To avoid injury from unexpected starting or electrical shock, do not plug the power cord into a source of power during unpacking and assembly. The cord must remain unplugged whenever you are adjusting/assembling the saw.

1. Remove the miter saw from the carton.  
**IMPORTANT:** Do not lift the miter saw by the switch handle or miter table handle. It may cause misalignment. Lift only by the built-in carrying handles located at the top of the machine.

2. Place the saw on a secure stationary work surface.
3. Separate all parts from the packing material. Check each one with the illustration below to make certain all items are accounted for before discarding any packing material.

### **▲ WARNING**

If any part is missing or damaged, do not attempt to assemble the miter saw, or plug in the power cord until the missing or damaged part is correctly replaced. To avoid electric shock, use only identical replacement parts when servicing double insulated tools. Call 1-800-4-MY-HOME® for replacement parts.

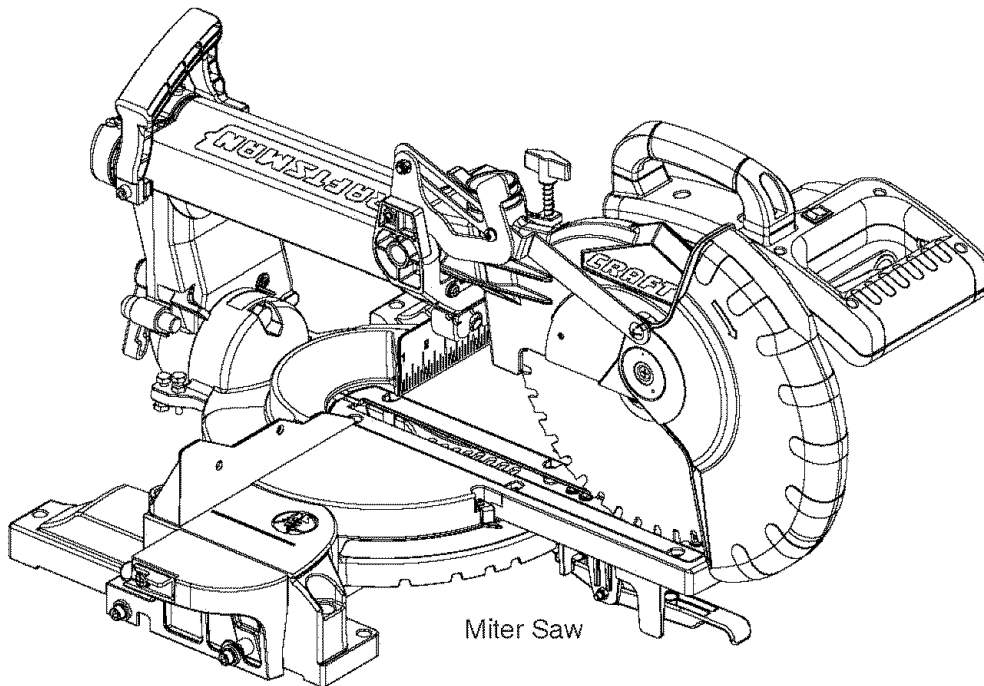

Blade Wrench

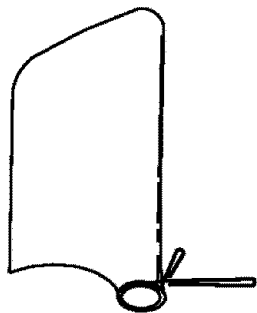

Dust Bag

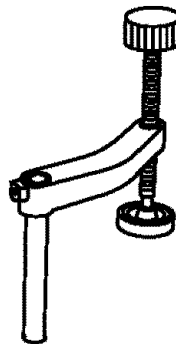

Hold-Down Clamp

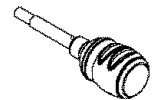

Miter Handle

# KNOW YOUR SLIDING COMPOUND MITER SAW

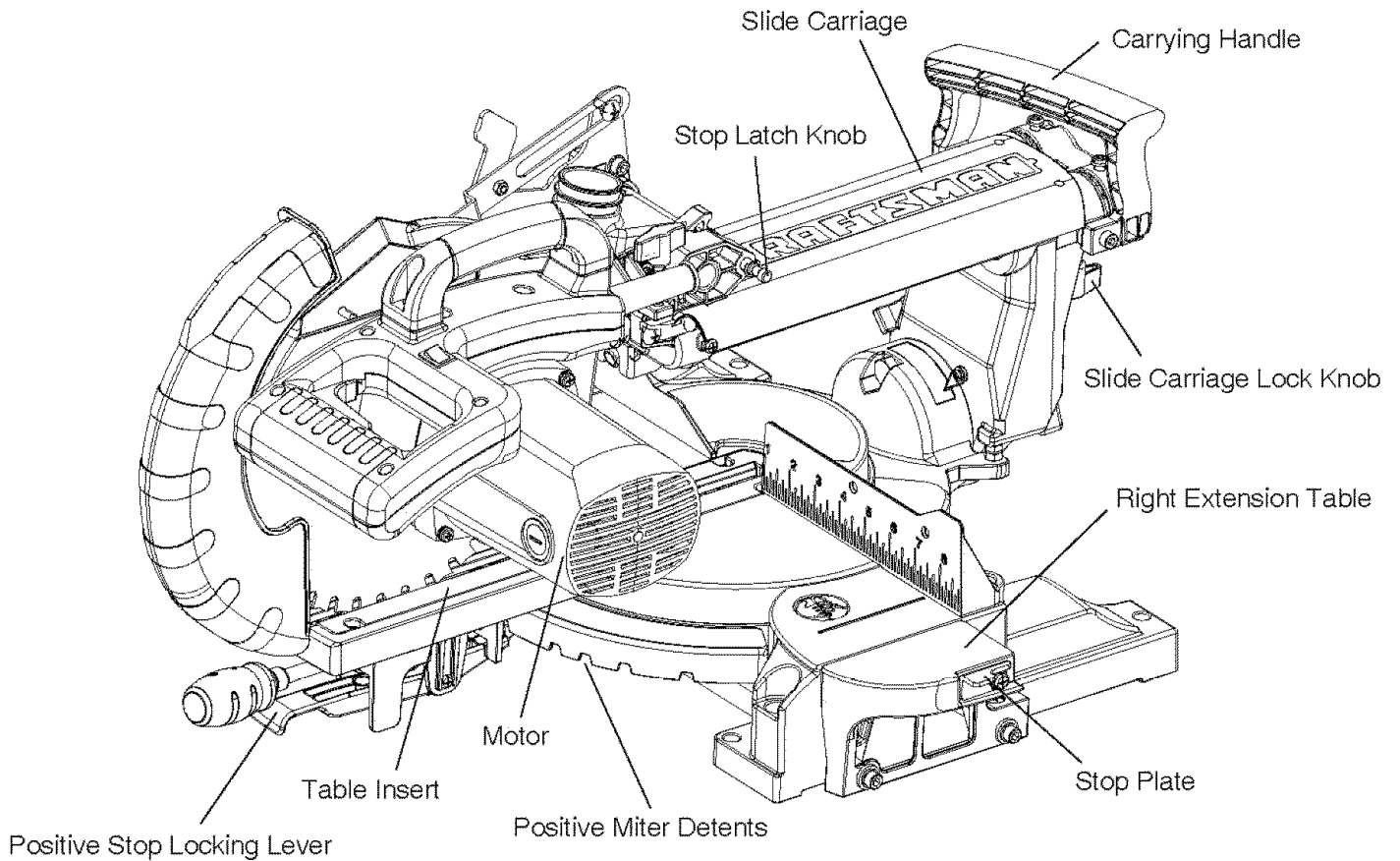
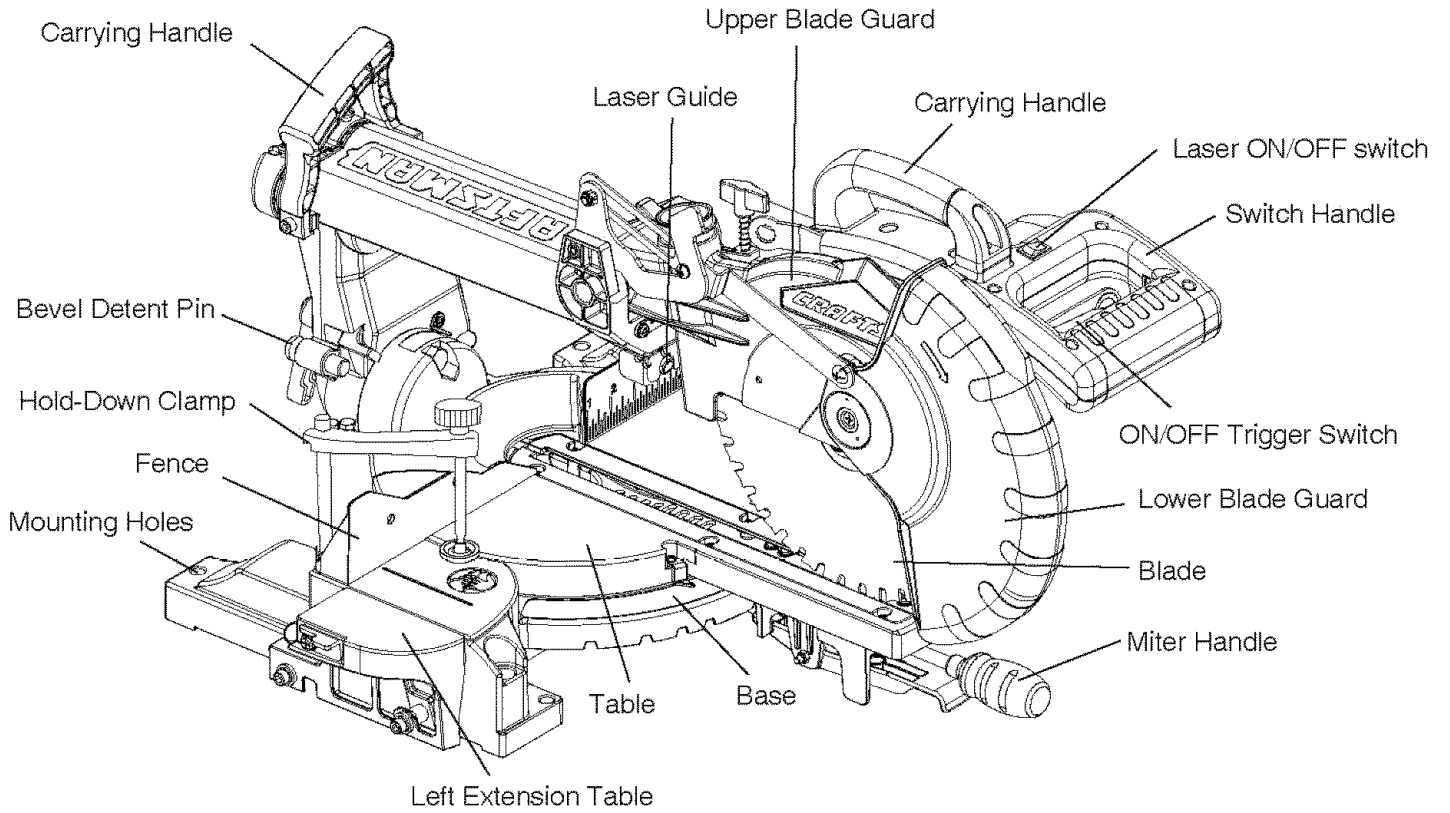

# GLOSSARY OF TERMS

**ARBOR LOCK** – Allows the user to keep the blade from rotating while tightening or loosening the arbor locking bolt during blade replacement or removal.

**BASE** – Supports the table, holds accessories and allows for workbench or leg set mounting.

**BEVEL LOCKING HANDLE** – Locks the miter saw at a desired bevel angle.

**BEVEL SCALE** – To measure the bevel angle of the saw blade 0° to 45° left.

**COVER PLATE SCREW** – Loosen this screw and rotate the plate for access to the blade arbor locking bolt.

**FENCE** – Helps to keep the workpiece from moving when sawing. Scaled to assist with accurate cutting.

**LOWER BLADE GUARD** – Helps protect your hands from the blade in the raised position. It retracts as the blade is lowered.

**MITER HANDLE** – Used to rotate the saw to the right or left cutting position.

**MITER SCALE** – To measure the miter angle 0° to 45° left, 0° to 45° right.

**MOUNTING HOLES** – Used to mount the miter saw to a stable surface.

**ON/OFF TRIGGER SWITCH** – To start the tool, squeeze the trigger. Release the trigger to stop the miter saw.

**POSITIVE STOP LOCKING LEVER** – Used in combination with the miter handle, it locks the miter saw at a preset positive stop for the desired miter angle.

**STOP LATCH** – Locks the miter saw in the lowered position for compact storage and transportation.

**SWITCH HANDLE** – The switch handle contains the trigger switch. The blade is lowered into the workpiece by pushing down on the handle. The saw will return to its upright position when the handle is released.

**WARNING LABELS** – Read and understand for your own safety. Always make certain these are in place and legible.

**WRENCH STORAGE** – Convenient storage to prevent misplacing the blade wrench.

## WOODWORKING TERMS

**ARBOR** – The shaft on which a blade is mounted.

**BEVEL CUT** – An angle cut made through the face of the workpiece.

**COMPOUND CUT** – A simultaneous bevel and miter cut.

**CROSSCUT** – A cut made across the width or grain of the workpiece.

**FREEHAND** – Performing a cut without using a fence (guide), hold down or other proper device to prevent the workpiece from twisting during the cutting operation.

**GUM** – A sticky sap from wood products.

**HEEL** – Misalignment of the blade.

**KERF** – The amount of material removed by blade cut.

**MITER CUT** – An angle cut made across the width or grain of the workpiece.

**RESIN** – A sticky sap that has hardened.

**REVOLUTIONS PER MINUTE (RPM)** – The number of turns completed by a spinning object in one minute.

**SAW BLADE PATH** – The area of the workpiece or table top directly in line with the travel of the blade or the part of the workpiece that will be cut.

**SET** – The distance between two saw blade tips, bent outward in opposite directions to each other. The farther apart the tips are, the greater the set.

**WORKPIECE** – The item being cut. The surfaces of a workpiece are commonly referred to as faces, ends and edges.

# ASSEMBLY

Estimated Assembly Time: 5 – 10 minutes

## **⚠ WARNING**

To avoid injury, do not connect this miter saw to the power source until it is completely assembled and adjusted and you have read and understood this Operator's Manual.

### INSTALLING THE MITER HANDLE (FIG. A)

1. Thread the miter handle (1) into the hole located at the front of the miter table.

Fig. A

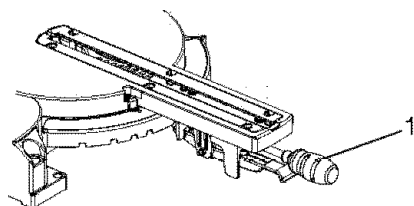

### UNLOCKING THE SLIDE CARRIAGE (FIG. B)

After removing the saw from the carton, loosen the slide carriage lock knob (1). When transporting or storing the miter saw, the slide carriage should always be locked in position. The slide carriage lock knob (1) is located on the bottom of the slide carriage.

Fig. B

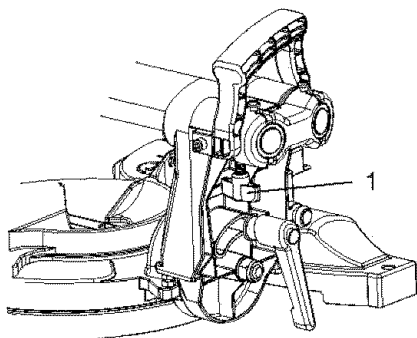

### SAW BLADE WRENCH (FIG. B-1)

1. For convenient storage and prevention of loss, there is a slot (1) in the rear of the carrying handle (2) for storing the blade wrench (3) when not in use.

Fig. B-1

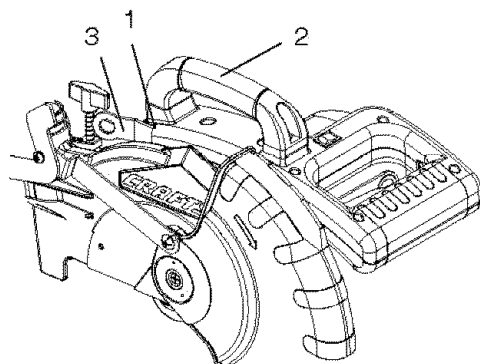

### CUTTING HEAD (FIG. C)

#### Raising

1. Push down slightly on the switch handle (1).
2. Pull out the stop latch knob (2).
3. Allow the cutting head to rise to the up position.

## **⚠ WARNING**

To avoid injury and damage to the saw, transport and store the miter saw with the cutting head locked in the down position. Never use the stop latch to hold the cutting head in a down position for cutting operations.

Fig. C

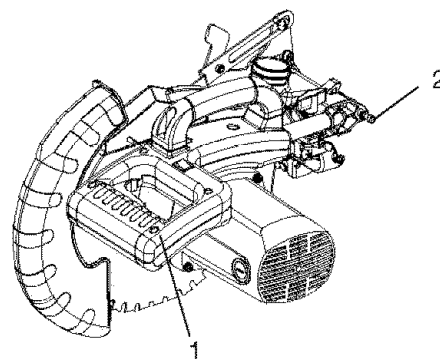

#### Locking

When transporting or storing the miter saw, the cutting head should always be locked in the down position.

1. Push the cutting head down to its lowest position.
2. Push the stop latch knob (2) into the locking hole.

**IMPORTANT:** To avoid damage, never carry the miter saw by the switch handle, the cutting arm or the miter handle. ALWAYS use the designated carrying handle.

### INSTALLING THE DUST BAG (FIG. D)

1. Squeeze the metal collar wings (2) of the dust bag (1).
2. Place the dust bag neck opening around the exhaust port (3), and release the metal collar wings.

Fig. D

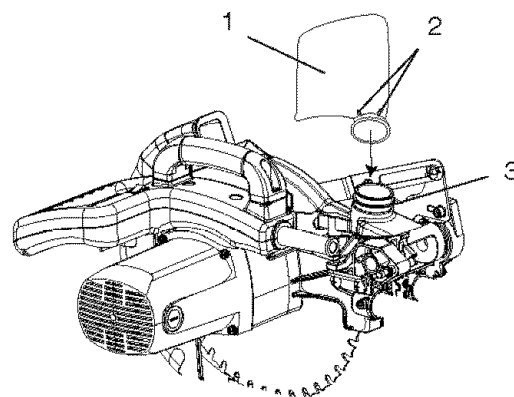

## INSTALLING THE HOLD-DOWN CLAMP

### (FIG. E and E-1)

1. Place the hold-down clamp assembly (1) in one of the mounting holes (2).

**NOTE:** There are no screws to secure clamp. The clamp will secure itself to the base when turning the knob (3) to clamp the workpiece. Do not use your other hand to hold the clamp when tightening. Only turn knob (3) to secure clamp to table. The clamp will tilt at an angle and secure itself when tightened.

#### **▲ WARNING**

When using stop block on the right side, hold-down clamp must also be in right side. Using hold-down clamp on the left side during this operation can cause kickback and serious injury to the operator.

Fig. E

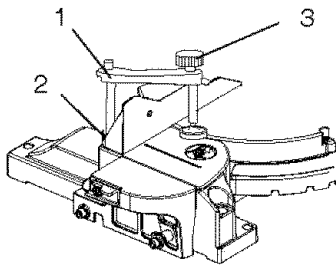
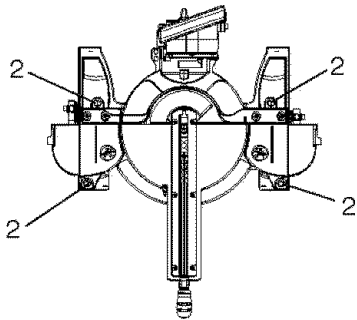

Fig. E-1



## REMOVING AND INSTALLING THE TABLE INSERT

### (FIG. F)

#### **▲ WARNING**

#### To avoid injury:

- Always unplug the saw to avoid accidental starting. Remove all small pieces of material from the table cavity before performing any cuts. The table insert may be removed for this purpose, but always reattach the table insert prior to performing a cutting operation.
- Do not start the sliding compound miter saw without checking for interference between the blade and table insert. Damage could result to the blade, table insert or turntable if blade strike occurs during the cutting operation.

1. To remove, loosen and remove the six screws (1) on the table insert (2) with a Phillips screwdriver and remove the insert.
2. To install, reposition the table insert, install the six screws and tighten.
3. Check for blade clearance by moving the slide carriage through the full motion of the blade in the table slot.

Fig. F

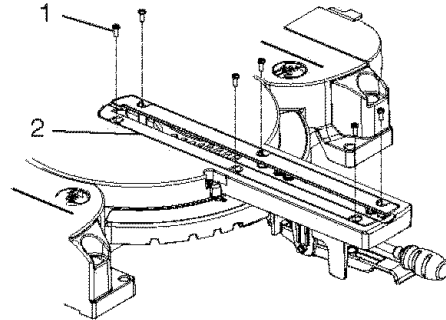

## MOUNTING THE MITER SAW (FIG. G, G-1)

#### **▲ WARNING**

#### To avoid injury from unexpected saw movement:

- Disconnect the power cord from the outlet, and lock the cutting head in the lower position using the stop latch.
- Lock the slide carriage in place by tightening the slide carriage lock knob.
- To avoid back injury, lift the saw by using the designated carrying handles located on the top of the machine. When lifting, bend at your knees, not from your back.
- Never carry the miter saw by the power cord or by the switch handle. Carrying the tool by the power cord could cause damage to the insulation or the wire connections resulting in electric shock or fire.
- To avoid injury from flying debris, do not allow visitors to stand near the saw during any cutting operation.
- Support the saw on a level work surface.
- Bolt or clamp the saw to its support.

## Mounting instructions

- For stationary use, place the saw in the desired location, directly on a workbench where there is room for handling and proper support of the workpiece. The base of the saw has four mounting holes. Bolt the base of the miter saw (1) to the work surface (5), using the fastening method as shown in Fig G.

Fig. G

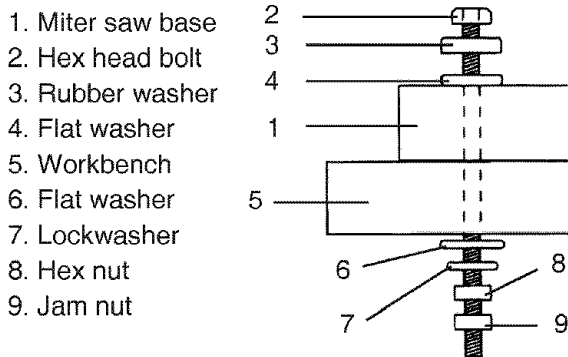

**NOTE:** Mounting hardware is not included with this tool. Bolts, nuts, washers and screws must be purchased separately.

- For portable use, place the saw on a 3/4 in. thick piece of plywood. Bolt the base of the miter saw securely to the plywood using the mounting holes on the base. Use C-clamps to clamp this mounting board to a stable work surface at the worksite. (Fig. G-1)

Fig. G-1

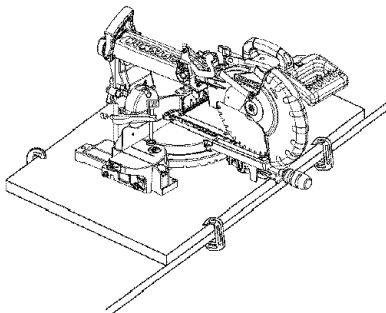

## REMOVING AND INSTALLING THE BLADE

### **WARNING**

Do not use a blade larger than 10 in. in diameter. To avoid injury from an accidental start, make sure the switch is in the OFF position and the plug is not connected to the power source outlet.

### Removing Blade (Fig. H, I and J)

- Unplug the saw from the outlet.
- Allow the cutting head to rise to the upright position. Raise the lower blade guard (1) to the up position.
- Loosen the cover plate screw (2) with a Phillips screwdriver.

- Rotate the cover plate (3) towards the rear of the tool to expose the arbor bolt (4).
- Place the blade wrench over the arbor bolt.

Fig. H

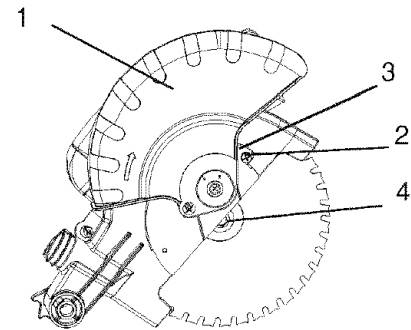

- Locate the arbor lock (5) on the motor, below the switch handle. (Fig. I)
- Press the arbor lock, holding it in firmly while turning the blade wrench clockwise. The arbor lock will engage after turning the wrench. Continue to hold the arbor locking to keep it engaged, while turning the wrench clockwise to loosen the arbor bolt.

Fig. I

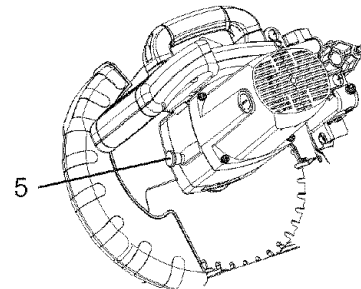

- Remove the arbor bolt (6), the outer blade collar (8) and the blade (7). Do not remove the inner blade collar. (Fig. J)

**NOTE:** Pay attention to the pieces removed, noting their position and direction they face. Wipe the blade collars clean of any sawdust before installing a new blade.

Fig. J

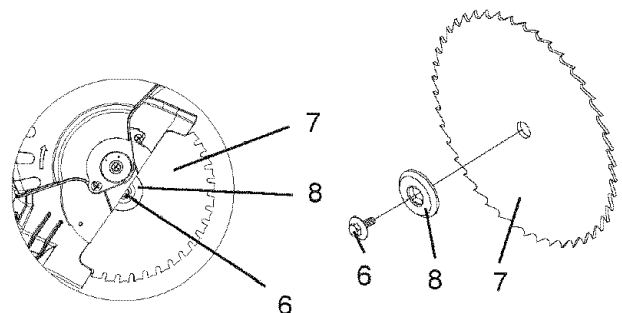

### Installing Blade (Fig. H, I, J)

Unplug the miter saw before changing/installing the blade.

1. Install a 10 in. blade with a 5/8 in. arbor, making sure the rotation arrow on the blade matches the clockwise rotation arrow on the upper guard and the blade teeth are pointing downward.
2. Place the outer blade collar (8) against the blade and on the arbor. Thread the arbor bolt (6) onto the arbor (Fig. J) in a counterclockwise direction.

**IMPORTANT:** Make sure the flats of the blade collars are engaged with the flats on the arbor shaft.

3. Place the blade wrench on the arbor bolt.
4. Press the arbor lock (5), holding it in firmly while turning the blade counterclockwise. When arbor lock engages, continue to press it in while tightening the arbor bolt securely.
5. Rotate the cover plate (3) back to its original position until the slot in the cover plate engages with the cover plate screw (2). While holding the lower blade guard, tighten the screw with a Phillips screwdriver. (Fig. H)
- NOTE:** The lower blade guard must be raised to the upright position to access the cover plate screw.
6. Lower the blade guard (1) and verify that the operation of the guard does not bind or stick. (Fig. H)
7. Be sure the arbor lock is released so the blade turns freely.

#### **▲ WARNING**

- To avoid injury, never use the saw without the cover plate secure in place. It keeps the arbor bolt from falling out if it accidentally loosens, and helps prevent the spinning blade from coming off the saw.
- Make sure the collars are clean and properly arranged. Lower the blade into the lower table and check for any contact with the base or the miter table by spinning the blade manually.

#### **▲ WARNING**

For your own safety, never connect the plug to power source outlet until all the adjustment steps are complete and you have read and understood the safety and operational instructions.

### THE LASER GUIDE (FIG. K)

#### **▲ WARNING**

Make the ON/OFF switch childproof. Insert a padlock, or chain with padlock, through the holes (2) in the trigger switch, locking the tool's switch, preventing children and other unqualified users from turning the machine on.

1. To turn laser on, press on/off rocker switch (1) to "ON" position.
2. To turn off laser, press on/off rocker switch (1) to "OFF" position.

Fig. K

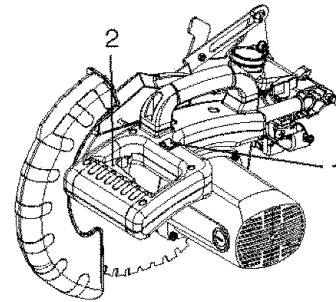

Your tool is equipped with the Laser Trac® cutting guide using Class II laser beam. The laser beam will enable to preview the saw blade path on the stock to be cut before starting the miter saw. This laser guide is powered by the transformed alternating current supply directly through the power lead. **The saw must be connected to the power source and the laser on/off switch must be turned on for the laser line to show.**

#### **▲ WARNING**

- **AVOID DIRECT EYE CONTACT**  
Laser radiated when laser guide is turned on. Avoid direct eye contact.
- **Laser Warning Label: Max output <1mW DIODE LASER: 630-670nm, Complies with 21CFR 1040.10 and 1040.11.**
- **CAUTION-Use of controls or adjustments or performance of procedures other than those specified herein may result in hazardous radiation exposure.**
- **CAUTION-The use of optical instruments with this product will increase eye hazard.**
- **Do not attempt to repair or disassemble the laser. If unqualified persons attempt to repair this laser product, serious injury may result. Any repair required on this laser product should be performed by authorized service center personnel.**

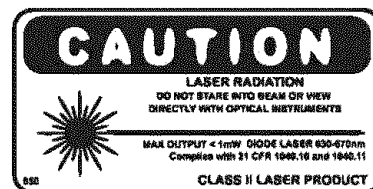

# ADJUSTMENT

## BEVEL STOP ADJUSTMENT

### **▲ WARNING**

To avoid injury from an accidental start, make sure the switch is in the OFF position and the plug is not connected to the power source outlet.

### 90° (0°) Bevel adjustment (Fig. L)

1. Loosen bevel lock handle (1) and tilt the cutting arm completely to the right. Tighten the bevel lock handle.
2. Place a combination square (2) on the miter table with the ruler against the table and the heel of the square against the saw blade.
3. If the blade is not 90° (0°) square with the miter table (5), loosen the bevel lock handle (1), tilt the cutting head to the left, loosen the locknut (4) on the bevel angle adjustment bolt (3) and use a 10 mm wrench to adjust the stop bolt (3) depth in or out to increase or decrease the bevel angle.
4. Tilt the cutting arm to back to the right at 90° (0°) bevel and recheck for alignment.
5. Repeat steps 1 through 4 if further adjustment is needed.
6. Tighten bevel lock handle (1) and locknut (4) when alignment is achieved.

Fig. L

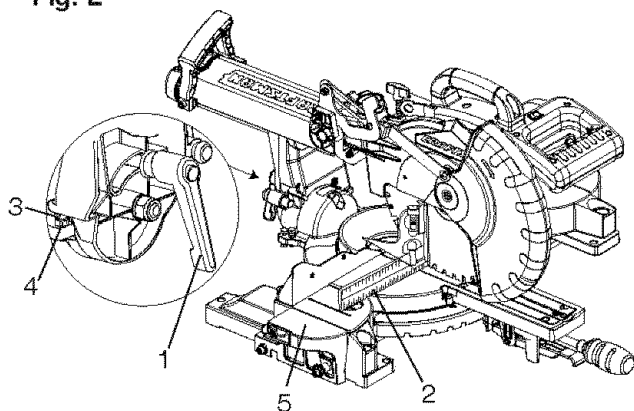

### 90° Bevel Pointer Adjustment (Fig. M)

1. When the blade is exactly 90° (0°) to the table, loosen the bevel indicator screw (5) using a # 2 Phillips screwdriver.
2. Adjust bevel indicator (6) to the "0" mark on the bevel scale and retighten the screw.

Fig. M

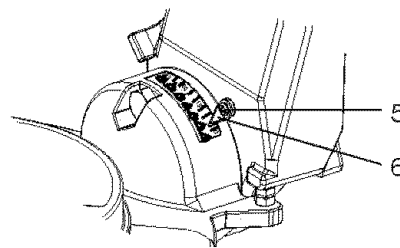

### 45° Bevel Adjustment (Fig. N)

1. Loosen the bevel lock handle (7) and tilt the cutting head completely to the left.
2. Using a combination square, check to see if the blade angle is 45° to the table.
3. If the blade is not at 45° to the miter table, tilt the cutting arm to the right, loosen the locknut (8) on the bevel angle adjustment bolt (9) and use a 10 mm wrench to adjust the stop bolt (9) depth in or out to increase or decrease the bevel angle.
4. Tilt the cutting arm to the left to 45° bevel and recheck for alignment.
5. Repeat steps 1 through 4 until the blade is at 45° to the miter table.
6. Tighten bevel lock handle (7) and locknut (8) when alignment is achieved.

Fig. N

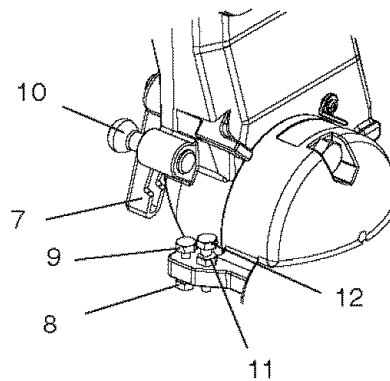

### 33.9° Bevel Adjustment (Fig. N)

1. Push the bevel detent pin (10) in toward the front of the unit.
2. Unlock the bevel lock handle and tilt the cutting arm to the crown molding positive stop at 33.9°.
3. Using a combination square, check to see if the blade angle is 33.9° to the table.
4. If the blade is not at 33.9° to the miter table, loosen locknut (11) and use a 10 mm wrench to adjust the bolt (12) in or out until the blade is at 33.9° to the miter table.
5. Secure the locknut (11) into position after alignment is achieved.

### MITER ANGLE ADJUSTMENT (FIG. O)

The sliding compound miter saw scale can be easily read, showing miter angles from 0° to 45° to the left, and 0° to 45° to the right. The miter saw table has nine of the most common angle settings with positive stops at 0°, 15°, 22.5°, 31.6°, and 45°. These positive stops position the blade at the desired angle quickly and accurately. Follow the process below for quickest and most accurate adjustments.

1. Unlock the miter table by turning the miter handle (1) counterclockwise.
2. Move the turntable while lifting up on the positive stop locking lever (2) to align the indicator (3) to the desired degree measurement.
3. If the desired angle is one of the nine positive stops, release the positive stop locking lever, making sure the lever snaps into position, and then secure by tightening the miter handle.
4. If the miter angle desired is not one of the nine positive stops, simply lock the miter table into position by turning the miter handle in the clockwise direction.

Fig. O

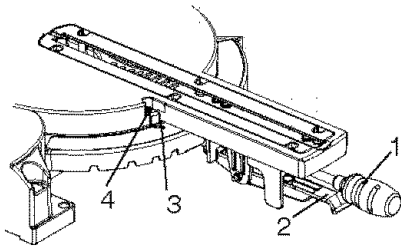

### MITER SCALE INDICATOR ADJUSTMENT (FIG. O)

1. Move the table to the 0° positive stop.
2. Loosen the screw (4) that holds the indicator with a Phillips screwdriver.
3. Adjust the indicator (3) to the 0° mark and retighten screw.

### ADJUSTING FENCE SQUARENESS (FIG. P)

1. Loosen the four fence locking bolts (1).
2. Lower the cutting arm and lock in position.
3. Using a square (3), lay the heel of the square against the blade and the ruler against the fence (2) as shown.
4. Adjust the fence 90° to the blade and tighten the four fence locking bolts.

**CAUTION: If the saw has not been used recently, recheck blade squareness to the fence and readjust if needed.**

5. After fence has been aligned, using a scrap piece of wood, make a cut at 90° then check squareness on the piece. Readjust if necessary.

Fig. P

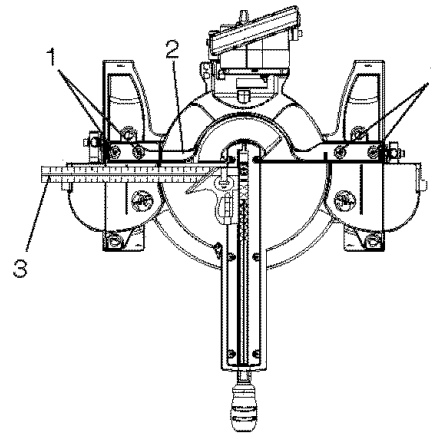

### SETTING CUTTING DEPTH (FIG. Q)

The depth of cut can be preset for even and repetitive shallow cuts.

1. Adjust the cutting head down (See CUTTING HEAD section) until the teeth of the blade are at the desired depth.
2. While holding the upper arm in that position, turn the stop knob (1) until it touches the stop plate (2).
3. Recheck the blade depth by moving the cutting head front to back through the full motion of a typical cut along the control arm.

Fig. Q

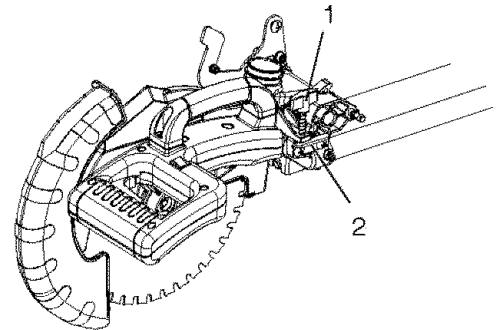

### ADJUSTING CUTTING DEPTH (FIG. Q)

The maximum depth travel of the cutting head was set at the factory. Check to see that the blade does not extend more than 1/4 in. below the table insert, and does not touch the control arm throat or any part of the base or table. If the maximum depth needs readjusting:

1. Loosen the stop knob (1) while moving the cutting head down until the blade extends just 1/4 in. below the table insert.
2. Adjust the stop knob (1) to touch the stop plate (2).
3. Recheck the blade depth by moving the cutting head front to back through the full motion of a cut along the control arm. If the blade touches the inside of the control arm, readjust the setting.

# OPERATION

## SAFETY INSTRUCTIONS FOR BASIC SAW OPERATIONS

### BEFORE USING THE MITER SAW

#### **WARNING**

To avoid mistakes that could cause serious, permanent injury, do not plug the tool in until the following steps are completed:

- Completely assemble and adjust the saw, following the instructions. **(SEE ASSEMBLY AND ADJUSTMENTS SECTIONS)**
- Learn the use and function of the ON/OFF switch, upper and lower blade guards, stop latch, bevel lock handle and cover plate screws.
- Review and understand all safety instructions and operating procedures in this Operator's Manual. **(SEE SAFETY AND OPERATIONS SECTIONS)**
- Review the **MAINTENANCE AND TROUBLESHOOTING GUIDE** for your miter saw.
- To avoid injury or possible death from electrical shock, make sure your fingers do not touch the plug's metal prongs when plugging in or unplugging your miter saw. **(SEE ELECTRICAL REQUIREMENTS AND SAFETY SECTIONS)**

### BEFORE EACH USE

#### Inspect your saw.

- **Disconnect the miter saw.** To avoid injury from accidental starting, unplug the saw before any adjustments, including setup and blade changes.
- **Compare the direction of rotation arrow** on the guard to the direction arrow on the blade. The blade teeth should always point downward at the front of the saw.
- **Tighten the arbor bolt.**
- **Tighten the cover plate screw.**
- **Check for damaged parts**, check for:
  - Alignment of moving parts
  - Damaged blade teeth
  - Damaged electric cords
  - Binding of moving parts
  - Mounting holes
  - Function of arm return spring and lower guard: Push the cutting arm all the way down, and then let it rise until it stops. The lower guard should close fully. Follow the instructions in the **TROUBLESHOOTING GUIDE** for adjustment, if necessary.
  - Other conditions that may affect the way the miter saw works.
- Keep all guards in place, in working order and properly adjusted. If any part of this miter saw is

missing, damaged or broken, or any electrical parts do not work, turn off the saw and unplug it.

- Replace bent, damaged, missing or defective parts before using the saw again.
- Maintain tools with care. Keep the miter saw clean for best and safest performance. Follow instructions for lubricating. Do not apply lubricants to the blade while it is spinning.
- Remove all adjusting wrenches from the tool before turning it on.
- To avoid injury from jams, slips, or thrown pieces, use only recommended accessories.

### RECOMMENDED ACCESSORIES

- Consult the **ACCESSORIES** and **ATTACHMENTS** section of this Operator's Manual for recommended accessories. Follow the instructions that come with the accessory. The use of improper accessories may cause risk of injury.
- Choose the correct 10 in. blade for the material and the type of cutting you plan to do. Do not use thin Kerf blades.
- Make sure the blade is sharp, undamaged and properly aligned. With the saw unplugged, push the cutting arm all the way down. Manually spin the blade and check for clearance. Tilt the miter head to a 45° bevel and repeat the test.
- Make sure the blade and arbor collars are clean.
- Make sure all clamps and locks are tight and there is no excessive play in any parts.

### KEEP YOUR WORK AREA CLEAN

Cluttered areas and benches invite accidents.

#### **WARNING**

To avoid burns or other fire damage, never use the miter saw near flammable liquids, vapors or gases.

- Plan ahead to protect your eyes, hands, face and ears.
- Know your miter saw. Read and understand the Operator's Manual and labels affixed to the tool. Learn its application and limitations as well as the potential hazards specific to this tool. To avoid injury from accidental contact with moving parts, do not lay out, assemble or set up work on the miter saw.
- Avoid accidental starting. Make sure the switch is in the OFF position before plugging the miter saw into a power outlet.

## PLAN YOUR WORK

Use the right tool. Do not force a tool or attachment to do a job it was not designed to do. Use a different tool for any workpiece that cannot be held in a solidly braced, fixed position.

### WARNING

**This machine is NOT designed for cutting masonry, masonry products or ferrous metals (steel, iron and iron-based metals.) Use this miter saw to cut only wood and wood by-products. Other materials may shatter, bind the blade or create other dangers. Remove all nails that may be in the workpiece to prevent sparking that could cause a fire.**

## DRESS FOR SAFETY

Any power tool can throw debris into the eyes. This can result in permanent eye damage. Everyday eyeglasses have only impact resistant lenses and are not safety glasses. Glasses or goggles not in compliance with ANSI Z87.1 could seriously injure you when they break.

- Do not wear loose clothing, gloves, neckties or jewelry (rings, watches). They can get caught and draw you into moving parts.
- Wear non-slip footwear.
- Tie back long hair.
- Roll long sleeves above the elbow.
- Noise levels vary widely. To avoid possible hearing damage, wear hearing protection when using any miter saw.
- For dusty operations, wear a dust mask along with safety goggles.

## INSPECT YOUR WORKPIECE

- Make sure there are no nails or foreign objects in the part of the workpiece being cut.
- Plan your work to avoid small pieces that may bind or are too small to clamp and hold securely.
- Plan the way you will grasp the workpiece from start to finish. Avoid awkward operations and hand positions. A sudden slip could cause your fingers or hand to move into the blade.

## DO NOT OVERREACH

Keep good footing and balance. Keep your face and body to one side, out of the line of a possible kickback. NEVER stand in the line of the blade.

### Never cut freehand:

- Brace your workpiece firmly against the fence and table stop so it will not rock or twist during the cut.
- Make sure there is no debris between the workpiece and the table or fence.
- Make sure there are no gaps between the workpiece, fence and table that will let the workpiece shift after it is cut.

- Keep the cut piece free to move sideways after it is cut off. Otherwise, it could get wedged against the blade and thrown violently.
- Only the workpiece should be on the saw's table.
- Secure work. Use clamps or a vise to help hold the work when it is practical.

## USE EXTRA CAUTION WITH LARGE OR ODD SHAPED WORKPIECES

- Use extra supports (tables, sawhorses, blocks, etc.) for workpieces large enough to tip.
- Never use another person as a substitute for a table extension or as an additional support for a workpiece that is longer or wider than the basic miter saw table, or to help feed, support or pull the workpiece.
- Do not use this saw to cut small pieces. If the workpiece being cut would cause your hand or fingers to be within 7-1/2 in. of the saw blade, the workpiece is too small. Keep hands and fingers out of the "no-hands zone" area marked on the saw's table.
- When cutting odd shaped workpieces, plan your work so it will not bind in the blade and cause injury. Molding, for example, must lie flat or be held by a fixture or jig that will not let it move when cut.
- Properly support round material such as dowel rods or tubing, which have a tendency to roll when cut, causing the blade to "bite."

### WARNING

**To avoid injury, follow all applicable safety instructions when cutting non-ferrous metals:**

- Use only saw blades specifically recommended for non-ferrous metal cutting.
- Do not cut metal workpieces that must be hand held. Clamp workpieces securely.
- Cut non-ferrous metals only if you are under the supervision of an experienced person and the dust bag has been removed from the saw.

## WHEN SAW IS RUNNING

### WARNING

**Do not allow familiarity from frequent use of your miter saw to result in a careless mistake. A careless fraction of a second is enough to cause a severe injury.**

**Before cutting, if the saw makes an unfamiliar noise or vibrates, stop immediately. Turn the saw OFF. Unplug the saw. Do not restart until you find and correct the problem.**

## BODY AND HAND POSITION (FIG. R)

### **▲ WARNING**

Never place hands near the cutting area. Proper positioning of your body and hands when operating the miter saw will make cutting easier and safer. Keep children away. Keep all visitors at a safe distance from the miter saw. Make sure bystanders are clear of the saw and workpiece. Don't force the saw. It will do the job better and safer at its designed rate.

#### Starting a cut:

- Place hands at least 7-1/2 in. away from the path of the blade – out of the “no-hands zone” (1).
- Hold workpiece firmly against the fence to prevent movement toward the blade.
- With the power switch OFF, bring the saw blade down to the workpiece to see the cutting path of the blade.
- Squeeze trigger switch to start saw.
- Lower blade into workpiece with a firm downward motion.

#### Finishing a cut:

- Hold the cutting arm in the down position.
- Release trigger switch and wait for all moving parts to stop before moving your hands and raising the cutting arm.
- If the blade doesn't stop within 6 seconds, unplug the saw and follow the instructions in TROUBLESHOOTING GUIDE section for adjusting the blade brake before using the saw again.

#### Before freeing jammed material:

- Release trigger switch.
- Wait for all moving parts to stop.
- Unplug the miter saw.

Fig. R

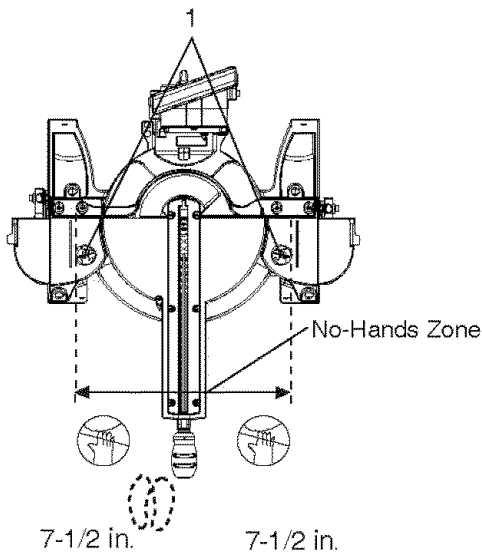

## BASIC SAW OPERATIONS

### **▲ WARNING**

For your convenience, your saw has a blade brake. The brake is not a safety device. Never rely on it to replace the proper use of the guard on your saw. If the blade doesn't stop within approximately 6 seconds, wait for the blade to stop, unplug the saw and contact customer service.

#### TO TURN SAW ON (FIG. S)

Squeeze the trigger switch (1) to turn the miter saw ON. Release the trigger switch to turn the saw OFF.

**NOTE:** Make the ON/OFF switch childproof. Insert a padlock, or chain with padlock, through the holes (2) in the trigger switch, locking the tool's switch, preventing children and other unqualified users from turning the machine on.

The miter saw is equipped with an automatic blade brake. When the trigger switch is released, the electric blade brake will stop the blade within approximately 6 seconds.

### **▲ WARNING**

To avoid injury, after completing a cut and releasing the trigger switch, allow the blade brake to activate and stop the blade before raising the cutting head.

### **▲ WARNING**

To avoid injury, check and tighten the arbor bolt periodically.

Fig. S

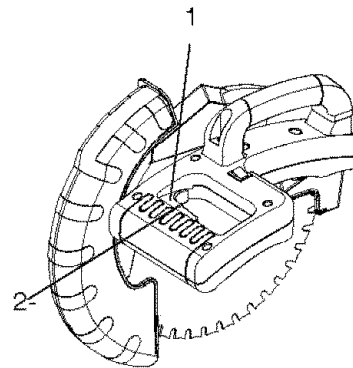

## SLIDING CARRIAGE SYSTEM (FIG. T)

### **WARNING**

To reduce the risk of injury, return carriage to the full rear position after each crosscut operation.

1. For chop cutting operations on small workpieces, slide the cutting head assembly completely toward the rear of the unit and tighten the carriage lock knob (1).
2. To cut wide boards up to 12 in., the carriage lock knob must be loosened to allow the cutting head to slide freely.

Fig. T

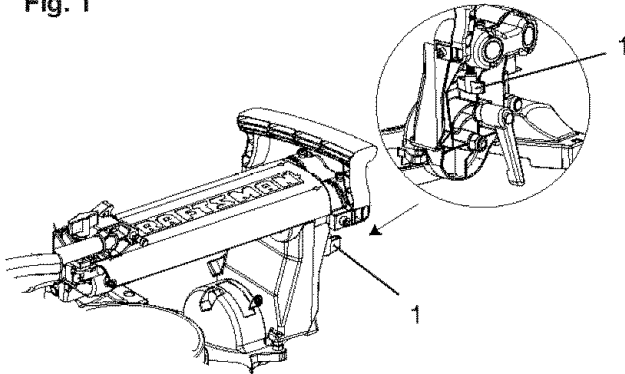

## BEFORE LEAVING THE SAW

- Never leave tool running unattended. Turn power OFF. Wait for all moving parts to stop.
- Make workshop childproof. Lock the shop. Disconnect master switches. Store tool away from children and other unqualified users.

### **WARNING**

To avoid injury from materials being thrown, always unplug the saw to avoid accidental starting, and remove small pieces of material from the table cavity.

## MITER CUT (FIG. U)

1. When a miter cut is required, unlock the miter table by turning the miter handle (1) counterclockwise.
2. While holding the miter handle, lift up on the positive stop locking lever (2).
3. Rotate the miter table to the right or left with the miter handle.

4. When the table is in the desired position, as shown on the miter scale (3), release the positive stop locking lever and tighten the miter handle. The table is now locked at the desired angle. Positive stops are provided at 0°, 15°, 22.5°, 31.6° and 45°.

**IMPORTANT:** Always tighten the miter table lock handle before performing every cutting operation.

Fig. U

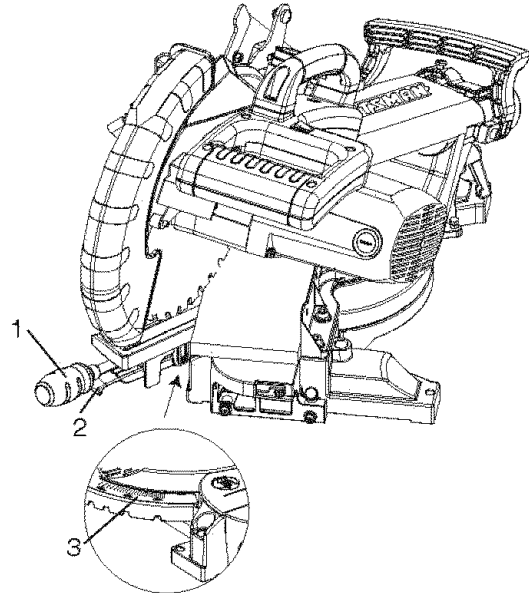

## BEVEL CUT (FIG. V)

1. When a bevel cut is required, loosen the bevel lock handle (1) by turning it clockwise.
2. Tilt the cutting head to the desired angle, as shown on the bevel scale (2).
3. The blade can be positioned at any angle, from a 90° straight cut (0° on the scale) to a 45° left bevel. Tighten the bevel lock handle (1) to lock the cutting head in position. Positive stops are provided at 0°, 33.9° and 45°.

Fig. V

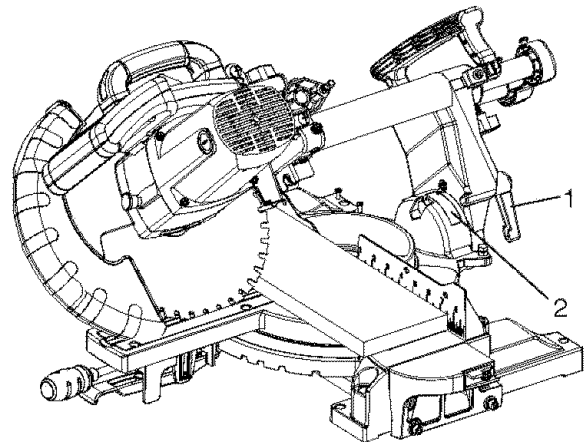

**NOTE:** The saw comes with a 33.9° crown molding stop.

### 33.9° BEVEL STOP FOR CROWN MOLDING (FIG. W)

1. Push the bevel detent stop pin (2) in toward the front of the machine.
2. Loosen the bevel lock handle (1).
3. Rotate the cutting head until the bevel detent pin stops the bevel angle at 33.9° on the bevel scale.
4. Tighten the bevel lock handle before making a cut.

**Fig. W**

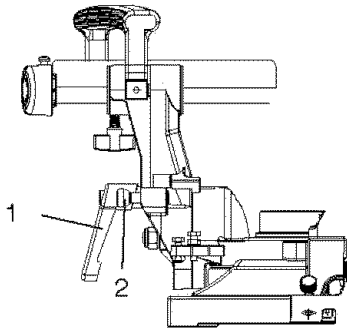

### COMPOUND CUT (FIG. X)

A compound cut is the combination of a miter and a bevel cut simultaneously.

1. Loosen the bevel lock handle (1) and position the cutting head at the desired bevel position. Lock the bevel lock handle.
2. Loosen the miter handle (2). Press down the positive stop locking lever (3) and position the table at the desired angle. Release the positive stop locking lever and lock the miter handle.

**Fig. X**

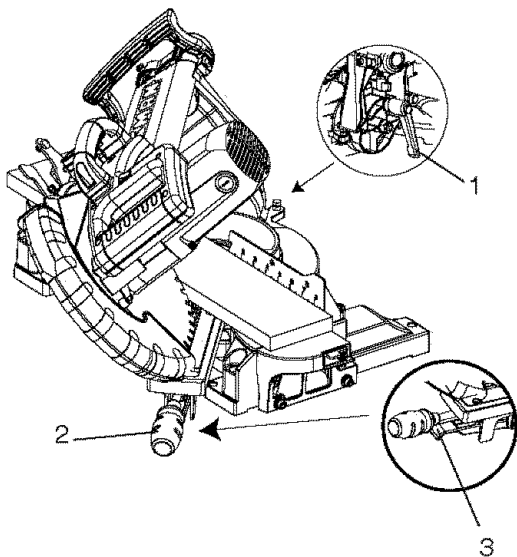

### SLIDE CUTTING WIDE BOARDS UP TO 12 in. WIDE (FIG. Y)

#### **WARNING**

#### To avoid injury:

- Never pull the cutting head assembly and spinning blade toward you during the cut. The blade may try to climb up on the top of the workpiece, causing the cutting assembly and spinning blade to kick back, forcefully. The cutting head assembly should be drawn back completely then pushed forward when sawing.
- Let the blade reach full speed before cutting. This will help reduce the risk of a thrown workpiece.

#### To Slide Cut Wide Boards (Fig. Y)

1. Unlock the carriage lock handle (1) and allow the cutting head assembly to move freely.
2. Set both the desired bevel angle and/or the miter angle and lock into position.
3. Use a hold down clamp to secure the workpiece.
4. Grasp the switch handle (2) and pull the carriage (3) forward until the center of the saw blade is over the front of the workpiece (4).
5. Engage the trigger to turn the saw on.
6. When the saw reaches full speed, push the switch handle down, slowly, cutting through the leading edge of the workpiece.
7. Slowly move the switch handle toward the fence, completing the cut.
8. Release the trigger and allow the blade to stop spinning before allowing the cutting head to raise.

**Fig. Y**

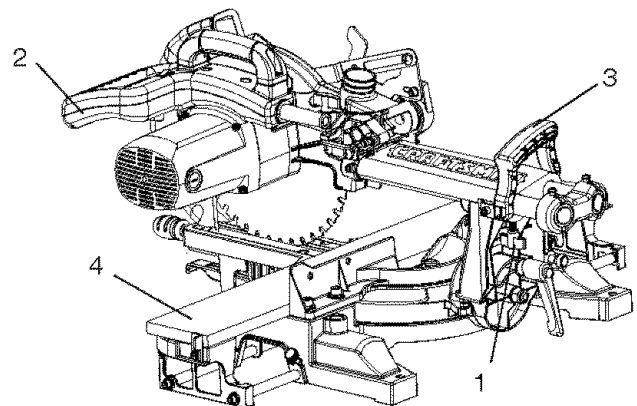

## CUTTING BOWED MATERIAL (FIG. Z)

A bowed workpiece must be positioned against the fence and secured with a clamping devise before cutting as shown. Do not position workpiece incorrectly or try to cut the workpiece without the support of the fence. This will cause the blade to bind and could result in personal injury.

Fig. Z

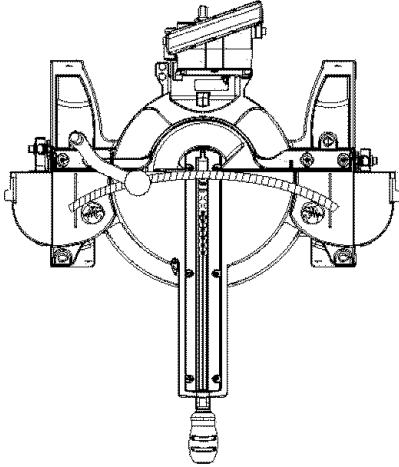

## WORKPIECE SUPPORT AND REPETITIVE CUTTING USING THE STOP PLATE (FIG. BB)

Long pieces need extension table support.

1. Loosen the knob (1) then slide the extension table to desired position and tighten the knob.
2. The stop plate is designed for use during repetitive cutting. Only use one stop plate at a time. Loosen the locking bolt (2), rotate the stop plate (3) to vertical position and retighten the locking bolt.

Fig. BB

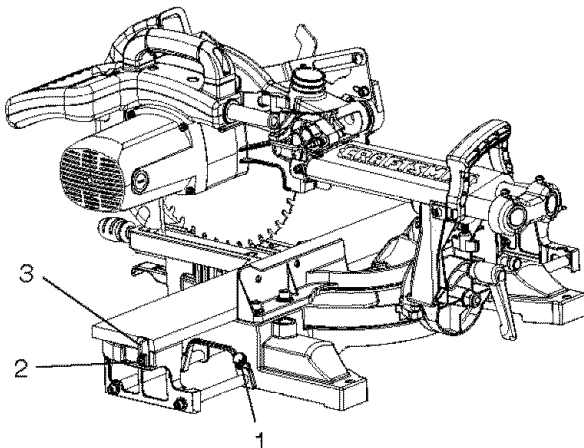

## AUXILIARY WOOD FENCE (FIG. CC)

When making multiple or repetitive cuts that result in cut-off pieces of one inch or less, it is possible for the saw blade to catch the cut-off piece and throw it out of the saw or into the blade guard and housing, possibly causing damage or injury. To minimize this, an auxiliary wood fence can be mounted to your saw.

Holes are provided in the saw fence to attach an auxiliary wood fence. This fence is to be constructed of straight wood approximately 3/4 in. thick by 2-1/2 in. high by 18 in. long.

Attach the wood fence securely and make a full depth cut to make a blade slot.

Check for interference between the wood fence and the lower blade guard. Adjust if necessary.

**NOTE:** This auxiliary fence is used only with the saw blade in the 0° bevel position (90° to the table). The auxiliary wood fence must be removed when bevel cutting.

Fig. CC

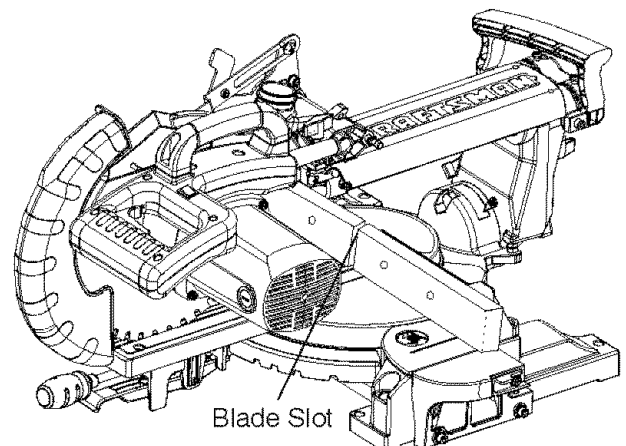

## CUTTING BASE MOLDING (FIG. DD)

Base moldings and many other moldings can be cut on a compound miter saw. The setup of the saw depends on molding characteristics and applications, as shown. Perform practice cuts on scrap material. To achieve best results:

1. Always make sure moldings rest firmly against fence and table. Use hold-down or C-clamps, whenever possible, and place tape on the area being clamped to avoid marks.
2. Reduce splintering by taping the cut area prior to making cut. Mark cut line directly on the tape.
3. Splintering typically happens due to wrong blade application and thickness of the material.

Fig. DD

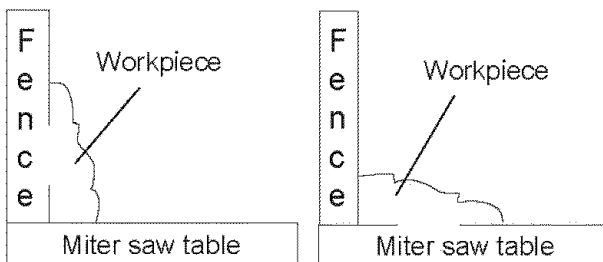

Miter at 45°, bevel at 0°      Miter at 0°, bevel at 45°

**NOTE:** Always perform a dry run cut so you can determine if the operation being attempted is possible before power is applied to the saw.

## CUTTING CROWN MOLDING (FIG. EE, FF)

Your compound miter saw is suited for the difficult task of cutting crown molding. To fit properly, crown molding must be compound-mitered with extreme accuracy. The two surfaces on a piece of crown molding that fit flat against the ceiling and wall are at angles that, **when added together, equal exactly 90°.**

Most crown molding has a top rear angle (the section that fits flat against the ceiling) of 52° and a bottom rear angle (the section that fits flat against the wall) of 38°. In order to accurately cut crown molding for a **90° inside or outside corner**, lay the molding with its broad back surface flat on the saw table.

When setting the bevel and miter angles for compound miters, remember that the settings are interdependent – changing one changes the other, as well.

Fig. EE

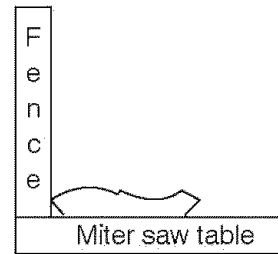

## Bevel/Miter Settings

Fig. FF

Settings for standard crown molding lying flat on compound miter saw table

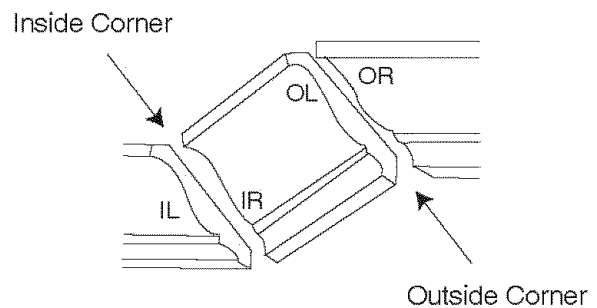

Compound Cut Crown Moldings

**NOTE:** The chart below references a compound cut for crown molding **ONLY WHEN THE ANGLE BETWEEN THE WALLS EQUALS 90°.**

KEY	BEVEL SETTING	MITER SETTING	TYPE OF CUT
<b>Inside corner-Left side</b>			
IL	33.9°	31.6° Right	1. Position top of molding against fence. 2. Miter table set at RIGHT 31.6°. 3. LEFT side is finished piece.
<b>Inside corner-Right side</b>			
IR	33.9°	31.6° Left	1. Position bottom of molding against fence. 2. Miter table set at LEFT 31.6°. 3. LEFT side is finished piece.
<b>Outside corner-Left side</b>			
OL	33.9°	31.6° Left	1. Position bottom of molding against fence. 2. Miter table set at LEFT 31.6°. 3. RIGHT side is finished piece.
<b>Outside corner-Right side</b>			
OR	33.9°	31.6° Right	1. Position top of molding against fence. 2. Miter table set at RIGHT 31.6°. 3. RIGHT side is finished piece.

# CROWN MOLDING CHART

## Compound Miter Saw Miter and Bevel Angle Settings Wall to Crown Molding Angle

Angle Between Walls	52/38° Crown Molding		45/45° Crown Molding	
	Miter Setting	Bevel Setting	Miter Setting	Bevel Setting
67	42.93	41.08	46.89	36.13
68	42.39	40.79	46.35	35.89
69	41.85	40.50	45.81	35.64
70	41.32	40.20	45.28	35.40
71	40.79	39.90	44.75	35.15
72	40.28	39.61	44.22	34.89
73	39.76	39.30	43.70	34.64
74	39.25	39.00	43.18	35.38
75	38.74	38.69	42.66	34.12
76	38.24	38.39	42.15	33.86
77	37.74	38.08	41.64	33.60
78	37.24	37.76	41.13	33.33
79	36.75	37.45	40.62	33.07
80	36.27	37.13	40.12	32.80
81	35.79	36.81	39.62	32.53
82	35.31	36.49	39.13	32.25
83	34.83	36.17	38.63	31.98
84	34.36	35.85	38.14	31.70
85	33.90	35.52	37.66	31.42
86	33.43	35.19	37.17	31.34
87	32.97	34.86	36.69	30.86
88	32.52	34.53	36.21	30.57
89	32.07	34.20	35.74	30.29
90	31.82	33.86	35.26	30.00
91	31.17	33.53	34.79	29.71
92	30.73	33.19	34.33	29.42
93	30.30	32.86	33.86	29.13
94	29.86	32.51	33.40	28.83
95	29.43	32.17	32.94	28.54
96	29.00	31.82	32.48	28.24
97	28.58	31.48	32.02	27.94
98	28.16	31.13	31.56	27.64
99	27.74	30.78	31.13	27.34
100	27.32	30.43	30.68	27.03
101	26.91	30.08	30.24	26.73
102	26.50	29.73	29.80	26.42
103	26.09	29.38	29.36	26.12
104	25.69	29.02	28.92	25.81
105	25.29	28.67	28.48	25.50
106	24.89	28.31	28.05	25.19
107	24.49	27.96	27.62	24.87
108	24.10	27.59	27.19	24.56
109	23.71	27.23	26.77	24.24
110	23.32	26.87	26.34	23.93
111	22.93	26.51	25.92	23.61
112	22.55	26.15	25.50	23.29
113	22.17	25.78	25.08	22.97
114	21.79	25.42	24.66	22.66
115	21.42	25.05	24.25	22.33
116	21.04	24.68	23.84	22.01
117	20.67	24.31	23.43	21.68
118	20.30	23.94	23.02	21.36
119	19.93	23.57	22.61	21.03
120	19.57	23.20	22.21	20.70
121	19.20	22.83	21.80	20.38
122	18.84	22.46	21.40	20.05
123	18.48	22.09	21.00	19.72

Angle Between Walls	52/38° Crown Molding		45/45° Crown Molding	
	Miter Setting	Bevel Setting	Miter Setting	Bevel Setting
124	18.13	21.71	20.61	19.39
125	17.77	21.34	20.21	19.06
126	17.42	20.96	19.81	18.72
127	17.06	20.59	19.42	18.39
128	16.71	20.21	19.03	18.06
129	16.37	19.83	18.64	17.72
130	16.02	19.45	18.25	17.39
131	15.67	19.07	17.86	17.05
132	15.33	18.69	17.48	16.71
133	14.99	18.31	17.09	16.38
134	14.66	17.93	16.71	16.04
135	14.30	17.55	16.32	15.70
136	13.97	17.17	15.94	15.36
137	13.63	16.79	15.56	15.02
138	13.30	16.40	15.19	14.62
139	12.96	16.02	14.81	14.34
140	12.63	15.64	14.43	14.00
141	12.30	15.25	14.06	13.65
142	11.97	14.87	13.68	13.31
143	11.64	14.48	13.31	12.97
144	11.31	14.09	12.94	12.62
145	10.99	13.71	12.57	12.29
146	10.66	13.32	12.20	11.93
147	10.34	12.93	11.83	11.59
148	10.01	12.54	11.46	11.24
149	9.69	12.16	11.09	10.89
150	9.37	11.77	10.73	10.55
151	9.05	11.38	10.36	10.20
152	8.73	10.99	10.00	9.85
153	8.41	10.60	9.63	9.50
154	8.09	10.21	9.27	9.15
155	7.77	9.82	8.91	8.80
156	7.46	9.43	8.55	8.45
157	7.14	9.04	8.19	8.10
158	6.82	8.65	7.83	7.75
159	6.51	8.26	7.47	7.40
160	6.20	7.86	7.11	7.05
161	5.88	7.47	6.75	6.70
162	5.57	7.08	6.39	6.35
163	5.26	6.69	6.03	6.00
164	4.95	6.30	5.68	5.65
165	4.63	5.90	5.32	5.30
166	4.32	5.51	4.96	4.94
167	4.01	5.12	4.61	4.59
168	3.70	4.72	4.25	4.24
169	3.39	4.33	3.90	3.89
170	3.08	3.94	3.54	3.53
171	2.77	3.54	3.19	3.10
172	2.47	3.15	2.83	2.83
173	2.15	2.75	2.48	2.47
174	1.85	2.36	2.12	2.12
175	1.54	1.97	1.77	1.77
176	1.23	1.58	1.41	1.41
177	0.92	1.18	1.06	1.06
178	0.62	0.79	0.71	0.71
179	0.31	0.39	0.35	0.35



# MAINTENANCE

## MAINTENANCE

### **▲ DANGER**

Never put lubricants on the blade while it is spinning.

### **▲ WARNING**

- To avoid fire or toxic reaction, never use gasoline, naphtha acetone, lacquer thinner or similar highly volatile solvents to clean the miter saw.
- To avoid injury from unexpected starting or electrical shock, unplug the power cord before working on the saw.
- For your safety, this saw is double insulated. To avoid electrical shock, fire or injury, use only parts identical to those identified in the parts list. Reassemble exactly as the original assembly to avoid electrical shock.

### REPLACING CARBON BRUSHES (FIG. GG)

Replace both carbon brushes when either has less than 1/4 in. length of carbon remaining, or if the spring or wire is damaged or burned. To inspect or replace brushes, first unplug the saw. Then remove the black plastic cap (1) on the side of the motor (2). Carefully remove the spring-loaded cap. Then pull out the brush and replace. Replace for the other side. To reassemble, reverse the procedure. The ears on the metal end of the assembly go in the same hole the carbon part fits into. Tighten the cap snugly, but do not overtighten.

**NOTE:** When reinstalling the same brushes, put them back in the way they came out. This will avoid a break-in period that reduces motor performance and increases wear.

Fig. GG

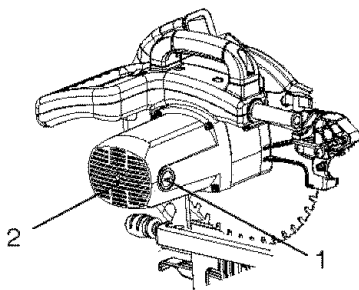

### LOWER BLADE GUARD

Do not use the saw without the lower blade guard. The lower blade guard is attached to the saw for your protection. Should the lower guard become damaged, do not use the saw until the damaged guard has been replaced. Check regularly to make sure the lower guard is working properly. Clean the lower guard of any dust or buildup with a damp cloth.

### **▲ WARNING**

- Do not use solvents on the guard. They could make the plastic “cloudy” and brittle.
- When cleaning the lower guard, unplug the saw from the power source receptacle to avoid unexpected start-up.

### SAWDUST

Periodically, sawdust will accumulate under the worktable and base. This could cause difficulty in the movement of the worktable when setting up a miter cut. Frequently blow out or vacuum up the sawdust.

### **▲ WARNING**

If blowing sawdust, wear proper eye protection to keep debris from blowing into eyes.

### LUBRICATION (FIG. HH)

All the motor bearings in this tool are lubricated with a sufficient amount of high-grade lubricant for the life of the unit under normal operating conditions; therefore, no further lubrication is required.

Lubricate the following as necessary:

**Chop pivot:** Apply light machine oil to points indicated in illustration.

**Central pivot of plastic guard:** Use light household oil (sewing machine oil) on metal-to-metal or metal-to-plastic guard contact areas as required for smooth, quiet operation. Avoid excessive oil, to which sawdust will cling.

**Link:** (which actuates the lower guard movement) may be oiled at the rear pivot, greased at ball bearing contact, and oiled where the link actuates the acetyl roller of the lower guard, if the down chop motion is hard to start.

Fig. HH

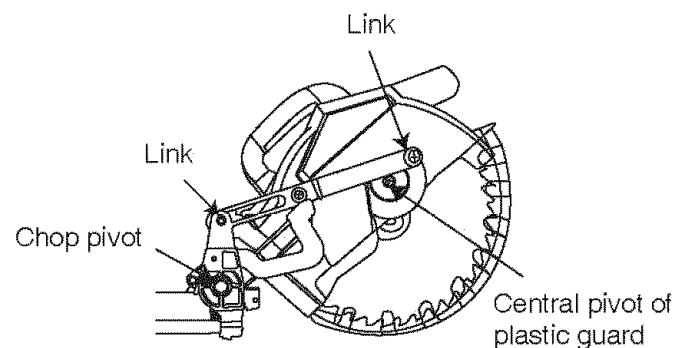

# TROUBLESHOOTING GUIDE

## WARNING

To avoid injury from accidental starting, always turn switch OFF and unplug the tool before moving, replacing the blade or making adjustments.

### TROUBLESHOOTING GUIDE - MOTOR

PROBLEM	PROBLEM CAUSE	SUGGESTED CORRECTIVE ACTION
Brake does not stop blade within 6 seconds.	<ol style="list-style-type: none"> <li>1. Motor brushes not sealed or lightly sticking.</li> <li>2. Motor brake overheated from use of defective or wrong size blade or rapid ON/OFF cycling.</li> <li>3. Arbor bolt loose.</li> <li>4. Brushes cracked, damaged, etc.</li> <li>5. Other.</li> </ol>	<ol style="list-style-type: none"> <li>1. Inspect/clean/replace brushes. See MAINTENANCE section.</li> <li>2. Use a recommended blade. Let cool down. See REMOVING OR INSTALLING THE BLADE section.</li> <li>3. Retighten. See REMOVING OR INSTALLING THE BLADE section.</li> <li>4. Replace brushes.</li> <li>5. Contact Sears Service Center.</li> </ol>
Motor does not start	<ol style="list-style-type: none"> <li>1. Limit switch failure</li> <li>2. Brush worn.</li> <li>3. Fuse blown or circuit breaker tripped on home panel.</li> <li>4. Other.</li> </ol>	<ol style="list-style-type: none"> <li>1. Replace limit switch.</li> <li>2. Replace brushes. See MAINTENANCE section.</li> <li>3. Verify there is electrical power at the outlet.</li> <li>4. Contact Sears Service Center.</li> </ol>
Brush spark when switch released.	<ol style="list-style-type: none"> <li>1. Brush worn.</li> <li>2. Other.</li> </ol>	<ol style="list-style-type: none"> <li>1. Replace Brushes. See MAINTENANCE section.</li> <li>2. Contact Sears Service Center.</li> </ol>

### TROUBLESHOOTING GUIDE - SAW OPERATION

PROBLEM	PROBLEM CAUSE	SUGGESTED CORRECTIVE ACTION
Blade hits table.	<ol style="list-style-type: none"> <li>1. Misalignment.</li> </ol>	<ol style="list-style-type: none"> <li>1. See ADJUSTMENT - Cutting Arm Travel section.</li> </ol>
Angle of cut not accurate. Can not adjust miter.	<ol style="list-style-type: none"> <li>1. Miter table unlocked.</li> <li>2. Sawdust under table.</li> </ol>	<ol style="list-style-type: none"> <li>1. See OPERATION - Miter Angle Adjustment section.</li> <li>2. Vacuum or blow out dust. WEAR EYE PROTECTION.</li> </ol>
Cutting arm wobbles.	<ol style="list-style-type: none"> <li>1. Loose pivot points.</li> </ol>	<ol style="list-style-type: none"> <li>1. See ADJUSTMENT - Cutting Arm Travel section.</li> </ol>
Cutting arm will not fully raise, or blade guard won't fully close.	<ol style="list-style-type: none"> <li>1. Pivot bolt too tight.</li> <li>2. Pivot spring not replaced properly after service.</li> <li>3. Sawdust build-up.</li> </ol>	<ol style="list-style-type: none"> <li>1. Loosen pivot bolt lock nut (see adjustment section).</li> <li>2. Contact Sears Service Center.</li> <li>3. See MAINTENANCE section.</li> </ol>
Blade binds, jams, burns wood.	<ol style="list-style-type: none"> <li>1. Improper operation.</li> <li>2. Dull or warped blade.</li> <li>3. Improper blade size.</li> <li>4. Wood is moving during cut.</li> </ol>	<ol style="list-style-type: none"> <li>1. See BASIC SAW OPERATION section.</li> <li>2. Replace or sharpen blade.</li> <li>3. Replace with 10 in. diameter blade.</li> <li>4. Use hold down clamp to secure workpiece to table.</li> </ol>
Saw vibrates or shakes.	<ol style="list-style-type: none"> <li>1. Saw blade not round / damaged / loose.</li> <li>2. Arbor bolt loose.</li> </ol>	<ol style="list-style-type: none"> <li>1. Replace blade.</li> <li>2. Tighten arbor bolt.</li> </ol>

# PARTS LIST

10 IN. SLIDING COMPOUND MITER SAW

MODEL NO. 137.212370



**WARNING**

When servicing use only CRAFTSMAN replacement parts. Use of any other parts may create a HAZARD or cause product damage. Any attempt to repair or replace electrical parts on this Miter Saw may create a HAZARD unless repair is done by a qualified service technician. Repair service is available at your nearest Sears Service Center.

## PARTS LIST FOR SAW SCHEMATIC

I.D No	Description	Size	Qty	I.D No	Description	Size	Qty
07WD	SLIDE PLATE		3	23US	SPRING PIN		1
083R	TRIGGER		1	250Z	HEX. SOCKET HD. CAP SCREW	M5*0.8-35	3
083Z	CORD CLAMP		1	25TD	MITER BAR		4
084W	WARNING LABEL		1	25TE	STOP BLOCK (LEFT)	#23	1
091S	COMPRESSION SPRING		1	25TF	STOP BLOCK (RIGHT)	#23	1
0CES	COMPRESSION SPRING		1	262V	ANCHOR PLATE		1
0CH3	COLLAR		1	26LU	WARNING LABEL		1
0CKS	SPRING WIRE		1	27KY	CLAMP BOLT		1
0CM3	HOLD-DOWN CLAMP ASS'Y		1	27PF	COMPRESSION SPRING		1
0CQH	BEVEL STOP LOCKING HANDLE		1	290M	WARNING LABEL		1
0CR8	SHAFT		1	2B5S	HEX. HD. BOLT	M10*1.5-75	1
0CT2	SHAFT SLEEVE		1	2BLG	SHAFT-PIVOT		1
0CV5	DUST BAG ASS'Y		1	2BLK	COLLAR		1
0DHT	SPRING GUARD		1	2B8T	FENCE	#AW	1
0DTH	CENTER BOLT		1	2BTL	COLLAR		1
0DVJ	BLADE WRENCH		1	2BTV	EXTENTION WING	#AW	1
0HXV	LINEAR MOTION BEARING		2	2C37	EXTENTION WING	#AW	1
0J4E	FLAT WASHER	φ6*13-1	1	2C8U	KNOB		2
0J4M	FLAT WASHER	φ12*21-1	1	2CD2	COMPRESSION SPRING		1
0J6A	FLAT WASHER	φ8*16-2.5	1	2CD7	SPRING PIN		2
0J74	FLAT WASHER	1/4*5/8-3/32	6	2D92	CONTROLLER ASS'Y		1
0J7G	FLAT WASHER	3/8*29/32-1/8	1	2DQC	MOTOR HANDLE		1
0JAZ	WAVE WASHER	WW-6	2	2DQD	MOTOR HANDLE		1
0JB0	WAVE WASHER	WW-8	2	2DUY	LEAD WIRE ASS'Y		1
0JBG	DISC SPRING WASHER	φ12	1	2DWF	BASE	#AW	1
0JEX	E-RING		1	2DWG	TABLE	#AW	1
0JMN	O-RING		1	2DWH	SUPPORT	#AW	1
0JMP	O-RING		1	2DWJ	TABLE INSERT		1
0JPE	HEX. HD. BOLT	M6*1.0-20	2	2DWK	TABLE INSERT		1
0JPF	HEX. HD. BOLT	M6*1.0-25	1	2DWL	PLUNGER HANDLE		1
0JX7	HEX. SOC. SET SCREW	M6*1.0-6	3	2DWP	NEEDLE POINTER		1
0JZN	ARBOR BOLT	M8*1.25-20	1	2DWQ	NEEDLE POINTER		1
0K2B	HEX SOC. HD. CAP SCREW	M6*1.0-16	7	2DWR	ARM-MITER	#AW	1
0K2L	HEX SOC. HD. CAP SCREW	M8*1.25-30	4	2DWS	BEARING COVER		2
0K5D	CR. RE. COUNT HD. SCREW	M6*1.0-20	1	2DWW	CLAMP BOLT		1
0K74	CR. RE. TRUSS HD. SCREW	M6*1.0-8	1	2DWX	SLIDE-BAR SEAT (FRONT)	#AW	1
0K7L	CR. RE. ROUND WASHER HD. SCREW	M6*1.0-16	2	2DWW	SLIDING RAIL		2
0K7X	CR. RE. TRUSS HD. ROUND NECK SCREW	M6*1.0-10	2	2DWZ	SLIDE-BAR SEAT (REAR)	#06	1
0K7Z	CR. RE. TRUSS HD. ROUND NECK SCREW	M6*1.0-14	2	2DX0	LEVER		1
0KA9	CR. RE. PAN HD. TAPPING SCREW	M3*24-10	1	2DX2	SLIDE-BAR BLADE GUARD		1
0KB7	CR. RE. PAN HD. TAPPING SCREW	M4*18-16	2	2DX4	PC-GUARD		1
0KB9	CR. RE. PAN HD. TAPPING SCREW	M5*16-10	1	2DX5	LEVER		1
0KB8	CR. RE. PAN HD. TAPPING SCREW	M4*18-25	4	2DX7	ARM	#AW	1
0KD6	CR. RE. PAN HD. SCREW	M4*0.7-8	5	2DX9	SEGMENT HADELE		1
0KD7	CR. RE. PAN HD. SCREW	M4*0.7-10	6	2DXA	COVER		1
0KDH	CR. RE. PAN HD. SCREW	M5*0.8-8	2	2DXF	SEGMENT HADELE		1
0KDM	CR. RE. PAN HD. SCREW	M5*0.8-20	1	2DXN	MOTOR		1
0KDR	CR. RE. PAN HD. SCREW	M5*0.8-10	3	2E5F	BRACING PLATE	#AW	1
0KDS	CR. RE. PAN HD. SCREW	M5*0.8-40	1	2E63	ROCKER SWITCH		1
0KDT	CR. RE. PAN HD. SCREW	M6*1.0-8	2	2EPB	TORSION SPRING		1
0KDV	CR. RE. PAN HD. SCREW	M6*1.0-16	4	2ESH	CUTTER SHAFT GUARD	#AW	1
0KE0	CR. RE. PAN HD. SCREW	M6*1.0-40	2	2EU9	STEEL GUARD		1
0KKK	CR. RE. PAN HD. ROUND NECK SCREW	M6*1.0-12	1	2EUA	PLASTIC GUARD		1
0KKX	CR. RE. PAN HD. ROUND NECK SCREW	M5*0.8-14	1	2EXC	LOCATION PIN		1
0KMR	HEX. NUT	M5*0.8 T=4	1	2EYT	POWER CABLE		1
0KMS	HEX. NUT	M6*1.0 T=5	4	2EYU	CR. RE. PAN HD. TAPPING SCREW	M5*12-30	1
0KQW	LOCK NUT	M5*0.8 T=5	1	2EYV	SPRING PIN		1
0KQX	NUT	M6*1.0 T=6	4	2F39	CLEVIS PIN		1
0KR0	NUT	M12*1.75 T=12	1	2F7P	LASER ASS'Y		1
0KR4	LOCK NUT	M8*1.25 T=8	1	2F9N	STICKER		1
0KTQ	CABLE CLAMP		1	2FCE	BRACKET-TILT		1
0KTS	CABLE CLAMP		1	2FCF	TILTING SCALE		1
0KUW	TERMINAL		2	2JAK	LOCKING HANDLE ASS'Y		1
0LU2	LIMIT SWITCH		1	2JAP	BLADE		1
0QQ1	CORD GUARD		1	2JL3	OPERATOR'S MANUAL		1
0S1S	COLLAR		1	2JNN	LABEL		1
0S2B	CR. RE. PAN HD. TAPPING SCREW	M6*1.0-25	2	2JNP	ROCKER SWITCH		1
0STZ	TRADE-MARK LABEL		1	2JNQ	TRADE-MARK LABEL		1
0U03	HEX. SOC. HD. CAP SCREW		2	2K8Q	WARNING LABEL		1
23LN	KNOB-HANDLE		1	2K96	WARNING LABEL		1
23NF	ARBOR COLLAR		2				





# 10 IN. SLIDING COMPOUND MITER SAW PARTS LIST AND SCHEMATIC FOR MOTOR

MODEL NO. 137.212370

I.D No.	Description	Size	Qty
0HV8	BALL BEARING	6201ZLU	1
0HVU	BALL BEARING	6200ZZ	1
0HX9	NEEDLE BEARING		1
0JX2	HEX. SOC SET SCREW	M5*0.8-6	2
OK43	CR. RE. PAN HD. SCREW & WASHER	M5*0.8-16	2
OK44	CR. RE. PAN HD. SCREW & WASHER	M5*0.8-12	1
OKCP	CR. RE.PAN HD.TAPPING SCREW & WASHER	M5*12-60	2
OKLA	PLASTIC SCREW	M5*0.8-6	2
OQ9K	FLOW GUIDE		1
OQGR	COMPRESSION SPRING		1
OQME	BRACKET STOP		1
OQMK	RUBBER CAP		1
OQMY	PROTECTOR WIRE		1
OQMZ	MOTOR COVER		1
OQQS	BRUSH HOLDER ASS'Y		2
OQQT	BRUSH ASS'Y		2
OQR0	BRUSH COVER		2
OQR2	BEARING BUSHING		1
OQYU	ARMATURE ASS'Y		1
1102	SPRING PIN		1
116D	LEAD WIRE ASS'Y -RED		1
21JM	ARBOR SHAFT ASS'Y		1
2B79	CR. RE. PAN HD. SCREW & WASHER	M5*0.8-35	4
2D2T	FIELD ASS'Y		1
2E70	GEAR BOX	#AW	1

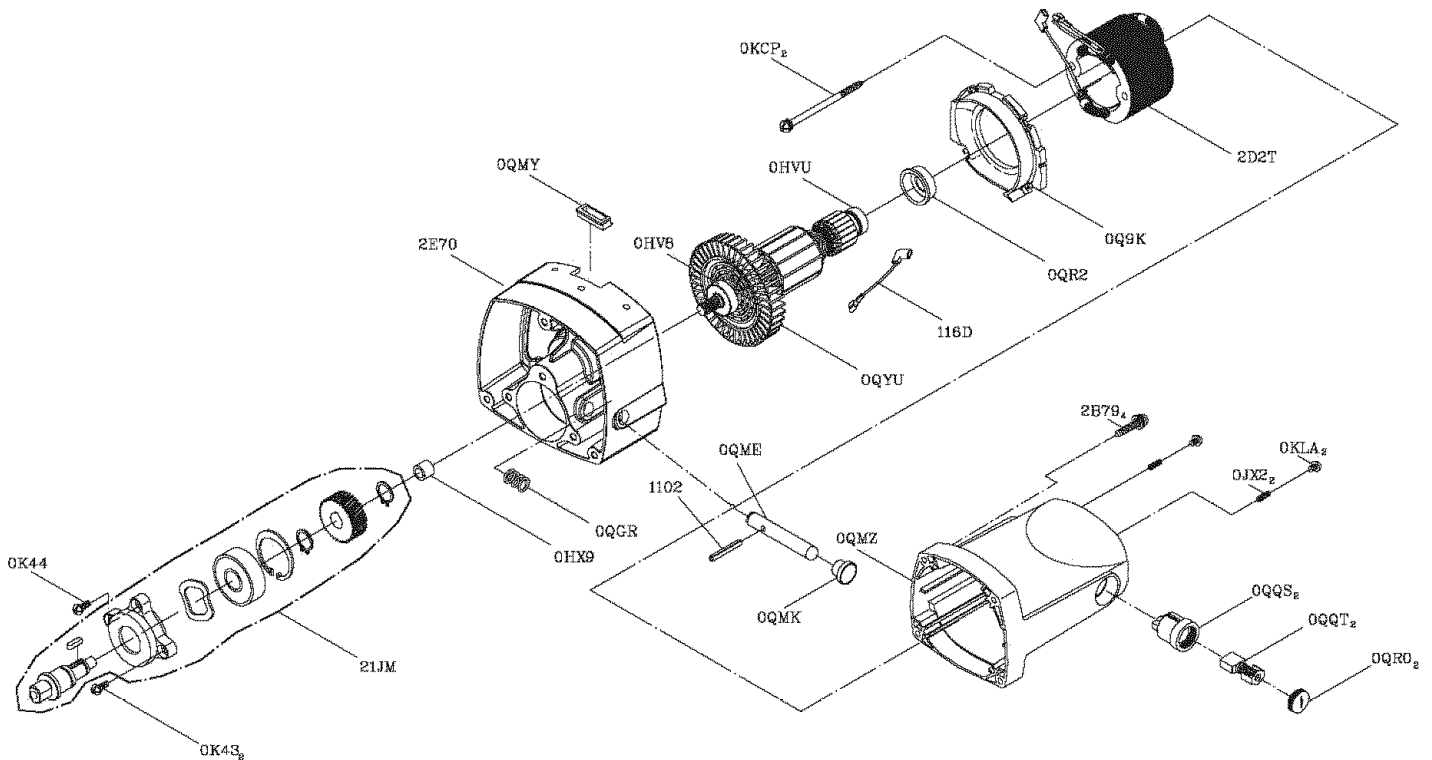

# NOTE

# Get it fixed, at your home or ours!

## Your Home

For repair – **in your home** – of **all** major brand appliances, lawn and garden equipment, or heating and cooling systems, **no matter who made it, no matter who sold it!**

For the replacement parts, accessories and owner's manuals that you need to do-it-yourself.

For Sears professional installation of home appliances and items like garage door openers and water heaters.

**1-800-4-MY-HOME® (1-800-469-4663)**

Call anytime, day or night (U.S.A. and Canada)

[www.sears.com](http://www.sears.com)      [www.sears.ca](http://www.sears.ca)

---

## Our Home

For repair of carry-in items like vacuums, lawn equipment, and electronics, call or go on-line for the location of your nearest

**Sears Parts & Repair Center.**

**1-800-488-1222**

Call anytime, day or night (U.S.A. only)

[www.sears.com](http://www.sears.com)

---

To purchase a protection agreement (U.S.A.) or maintenance agreement (Canada) on a product serviced by Sears:

**1-800-827-6655 (U.S.A.)**

**1-800-361-6665 (Canada)**

---

Para pedir servicio de reparación a domicilio, y para ordenar piezas:

**1-888-SU-HOGAR®**

(1-888-784-6427)

Au Canada pour service en français:

**1-800-LE-FOYER<sup>MC</sup>**

(1-800-533-6937)

[www.sears.ca](http://www.sears.ca)

