

## **Installation instructions and user guide**

### **Ice & Water refrigerator**

E402B, E442B and E522B models

NZ AU US CA UK AE HK SG MY

# Introduction

Thank you for buying a Fisher & Paykel *Active Smart™* refrigerator with automatic ice dispensing and chilled water through the door.

At Fisher & Paykel we are very proud of this refrigerator. We feel we have achieved water dispensing through the door without compromising the storage space or access in the fridge. During our testing we have enjoyed the health benefits of having cool filtered water so accessible, while minimising the number of door openings.

Thousands of hours of food care research and 70 years of refrigeration experience has been programmed into your refrigerator to give you the best possible performance.



We hope you enjoy your new refrigerator.

## Before you start using your Ice & Water refrigerator

- Check refrigerator is switched on and has cooled for at least 2 hours (refer to page 15 – The temperature of your refrigerator and freezer) before use.
- Check that the water filter has been connected and turned on.
- Turn on ice maker.
- At first use allow approximately 1 minute from when the dispensing pad is pushed until water is dispensed. This will allow the tank to fill.
- Run through and discard the first 3 L or 3 qt of water from the dispenser (refer to page 10 – First use).
- Discard the first bin of ice (refer to page 11 – First use).

You are now ready to enjoy ice and water from your *Active Smart™* refrigerator.

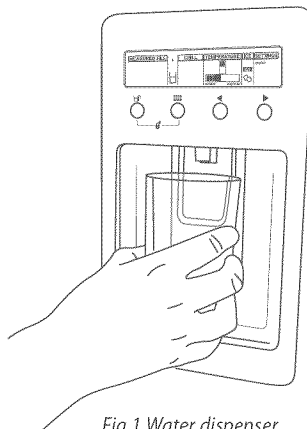

Fig.1 Water dispenser

Important safety instructions	2
Installation instructions	4
All about the display	8
Using your water dispenser	10
Using your ice maker	11
Fridge options	13
Measured Fill	13
Freezer Chill and Bottle Chill	14
The temperature of your refrigerator and freezer	15
Settings/User warnings	16
Water filter	18
Measured Fill Calibration	20
Trouble shooting	21
Cleaning and caring for your refrigerator	23
On vacation/holiday	23
Manufacturers warranty	24
Performance data sheet	26

## ***Important!***

*This Ice & Water refrigerator booklet contains specific information about the ice and water function on your refrigerator.*

*Please use this booklet in conjunction with the Refrigerator & Freezer User Guide supplied with your refrigerator.*

## **SAVE THESE INSTRUCTIONS**

The models shown in this user guide may not be available in all markets and are subject to change at any time. For current details about model and specification availability in your country, please go to our website [www.fisherpaykel.com](http://www.fisherpaykel.com) or contact your local Fisher & Paykel dealer.

## 2 Important safety instructions

To reduce the risk of fire, electric shock, or injury to persons read the IMPORTANT SAFETY PRECAUTIONS before operating this appliance.

Use this appliance only for its intended purpose as described in this User Guide.

### ***Important safety precautions***

#### **Warning**

*When using this appliance always exercise basic safety precautions including the following:*

#### **Danger**

- *This appliance is not intended for use by young children or infirm persons without supervision. Young children should be supervised to ensure they do not play with the appliance.*
- *Risk of child entrapment. Before you throw away your old refrigerator or freezer:*
  - *Take off the doors*
  - *Leave the shelves in place so that children may not easily climb inside.*

#### **Disposal**

- *Extreme care must be taken when disposing of your old appliance to avoid hazards. The refrigerant gas must be safely removed and for the safety of young children, remove doors.*
- *Your Fisher & Paykel Appliances Authorised Service Centre will be able to give advice on environmentally friendly methods of disposing of your old refrigerator or freezer.*

#### **Electrical**

- *This appliance must be properly installed in accordance with the installation instructions before it is used.*
- *Never unplug your refrigerator or freezer by pulling on the power cord.*
- *Always grip the plug firmly and pull straight out from the outlet.*
- *Do not plug in any other appliance at the same power point as your refrigerator or freezer or use extension cords or double adapters.*
- *Repair or replace immediately all electric service cords that have become frayed or otherwise damaged. Do not use a cord that shows cracks or abrasion along its length or at either the plug or appliance end.*

*If the power supply cord is damaged, it must only be replaced by your Fisher & Paykel Appliances Authorised Service Centre because special purpose tools are required.*
- *When moving your appliance away from the wall, be careful not to roll over or damage the power cord.*
- *Unplug your refrigerator or freezer before cleaning or replacing the lightbulb.*

## Storing food and drinks

- *Never store volatile or flammable materials in your refrigerator or freezer as they may explode.*
- *Never freeze liquids in glass containers. Liquid expands during freezing, which may cause the container to explode.*
- *Never freeze carbonated drinks. They may explode.*
- *Do not consume food if it is too cold. Food removed from the freezer compartment may be cold enough to cause damage when brought into contact with bare skin e.g. frozen ice cubes.*

## Power failure – food safety

- *Do not refreeze frozen foods that have thawed completely. Follow the recommendations below if you discover food in your freezer has thawed:*
  - 1) *Ice crystals still visible – food may be refrozen but should be stored for a shorter period than recommended.*
  - 2) *Thawed but refrigerator cold – refreezing generally not recommended. Fruits and some cooked food can be refrozen but use as soon as possible. Meat, fish, poultry – use immediately or cook then refreeze. Vegetables – discard as they usually go limp and soggy.*
  - 3) *Thawed but warmer than 4 °C (38 °F). Red meat can be cooked immediately and refrozen but use as soon as possible. Discard all other frozen foods.*
- *Do not refreeze frozen foods that have thawed completely. The food may be dangerous to eat.*

## Cleaning

- *Many commercially available cleaning products contain solvents which may attack plastic components of your refrigerator or freezer and cause them to crack. Please refer to the cleaning care section of this booklet for further advice.*

**SAVE THESE INSTRUCTIONS**

## 4 Installation instructions

### Contents of kit

- 1 4 m (13 ft) white 6 mm (¼") tubing
- 2 1 x 200 mm (8") blue tubing
- 3 1 x pressure reducing valve (PRV)
- 4 1 x double sided foam
- 5 2 x locking keys
- 6 1 x water filter cartridge and head
- 7 1 x tap connection – USA market – 7/16" UNS  
– All other markets – 15 mm (½") BSP

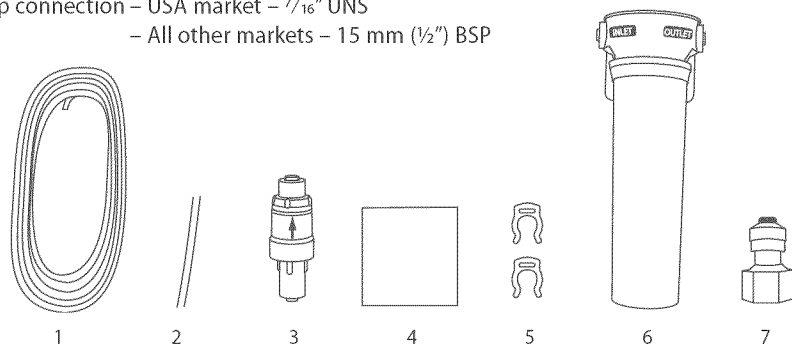

Fig.3 Water connection kit

### Important!

- It is imperative the pressure reducing valve (PRV) is fitted prior to the filter. This valve ensures the water will not flow back into the mains from the refrigerator water system. If the PRV is not fitted to the connection line your Ice & Water refrigerator features may not function in some circumstances.
- It is recommended that an authorised plumber in your state or town is used to install the water connection.
- The new tubings supplied with the machine are to be used, old tubings should not be used.

### Installation precautions/warning

- DO NOT use with water that is microbiologically unsafe or of unknown quality without adequate disinfection before or after the system.
- WARNING – connect to potable water supply only.
- DO NOT install on line pressure above 900 kPa (130 psi) or below 150 kPa (22 psi).
- DO NOT use on hot water supply (38°C [100°F max.]).
- DO NOT install near electrical wires or water pipes that will be in the path of drilling when selecting the location of filter system.
- DO NOT mount filter in such a position so that it will be struck by other items, such as wastebaskets, etc.
- DO NOT install the filter in direct sunlight as prolonged exposure to light can weaken plastic components.
- DO NOT install in a location that is susceptible to freezing temperatures as damage to the housing could occur.
- DO NOT screw filter to fridge.
- AVOID contamination of pipes during installation.

## Installation instructions:

- 1 Ensure that refrigerator is not plugged into a power supply.
- 2 Remove the compressor compartment cover from the rear of the refrigerator (USA market only).
- 3 Locate isolation tap for water connection – cold water feed only (dishwasher or sink mixer taps) – if you can't find the connection tap, contact an authorised plumber in your state or town to fit your water connection.

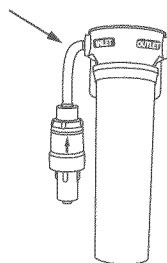

Diagram 1  
Fig.4 PRV connection

- 4 Connect the 200 mm (8") blue tubing to the outlet of the PRV (blue collet) and the inlet connection of the water filter cartridge as shown in Diagram 1. Gently pull on both ends to ensure it is locked.

- 5 Connect the white 6 mm (¼") tubing to the outlet of the water filter cartridge as shown in Diagram 2. Gently pull to ensure it is locked.

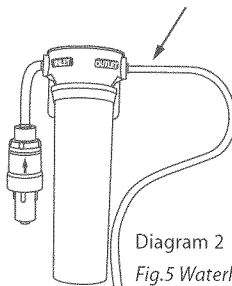

Diagram 2  
Fig.5 Waterline connection

- 6 Measure the required length of tubing to run from the PRV to the water connection point.

- 7 Cut the tubing making sure the ends are square and clean.

- 8 Connect the tubing to the tap connection and the base of the PRV (white collet) and then to the tap as shown in Diagram 3. Please note that the tap connection supplied should fit most installation situations. If your tap requires a different fitting, please contact an authorised plumber in your state or town to purchase the correct fitting.

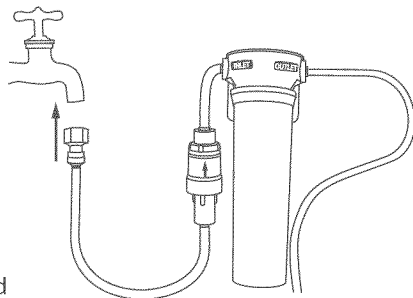

Diagram 3  
Fig.6 Tap connection

- 9 Connect one locking key to each side of the water filter cartridge in between the cartridge and the locking collet as shown in Diagram 4.

- 10 To flush the water filter and check for leaks, aim the end of the tubing into a bucket, turn isolating tap on and run at least 3 litres (3 qt) of water through. Once complete, turn isolating tap off.

- 11 Locate desired position for water filter noting carefully the following points:

- It is recommended to fit the filter in a vertical orientation with the water filter head at the top. This will minimise water leakage when replacing cartridge.
- Ensure the filter is in a convenient location to access every 6 months for replacement. We suggest that this location is beside the water filter supply tap in the cupboard beside the refrigerator.
- A minimum clearance of 64 mm (2 ½") from the bottom of the filter cartridge is required to perform cartridge removal.
- Do not screw filter to fridge.

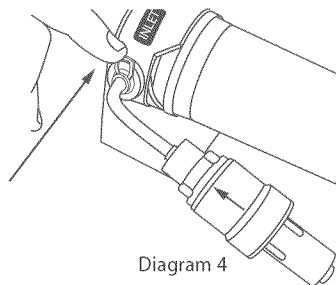

Diagram 4  
Fig.7 Locking key

## 6 Installation instructions

- 12 Attach double sided foam to the back of the water filter head as shown in Diagram 5. Write the date to be replaced on the filter (date installed + 6 months). Remove double sided foam backing and attach filter to the desired position as located in step 11 (refer to previous page).
- 13 Run the 6 mm (¼") tubing to back of the fridge ensuring there is enough tubing to pull out the refrigerator for service.
- 14 Connect tubing into the water (solenoid) valve located on the right hand side of the unit (compressor) compartment as shown in Diagram 7. Beware of hot pipes.
- 15 Pull gently on tubing to ensure it is locked in as shown in Diagram 8.
- 16 The completed installation should look like Diagram 9 on page 7.



Diagram 5

*Fig.8 Double sided foam attachment*

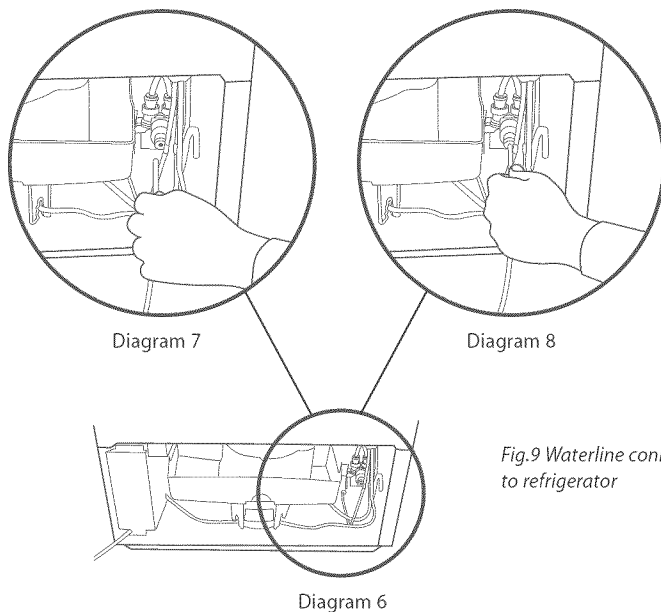



Diagram 7

Diagram 8

Diagram 6

*Fig.9 Waterline connection to refrigerator*

- 17 Turn isolating tap on and check that all connections are dry and free of drips.
- 18 Coil water line tubing behind the fridge. Push your refrigerator into place being careful not to kink or squash the water line running into the water (solenoid) valve.
- 19 Turn on refrigerator.
- 20 The first time you require water out of the dispenser, there will be a delay while the water reservoir fills up. As this is happening, the  symbol will flash. Once the reservoir is full, this symbol will stop flashing.
- 21 Run a further 3 litres (3 qt) through the system to ensure the reservoir is flushed out.
- 22 You are now ready to enjoy chilled water and ice dispensing from your *Active Smart™* refrigerator.

## **Important!**

- All connections must be checked for leaks.
- If unsure of connection process and/or leaks then contact your local plumber to install and check the system for you.
- Ensure white 6 mm (¼") tubing is routed away from sharp objects, sharp corners (beware of kinking tube as this will stop water flow), clear of the refrigerator unit compartment and not in a location where it can be squashed.
- Ensure all push-fit connections are firmly pushed into place. The tube should push in 20 mm (¾") before reaching the stop.
- If tubing is removed at any point, re-cut the end and re-insert. Tubing must be fully inserted to avoid leaks.
- To remove tube from connection points, turn off the isolating tap, push in the collet and gently pull tubing at the same time.

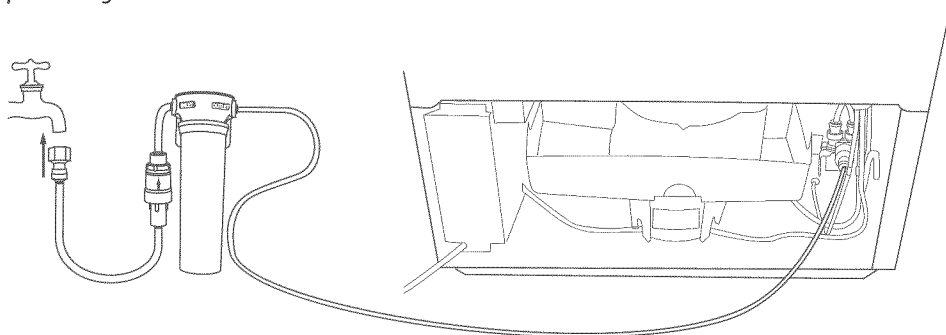

Fig.10 Connection to water supply

Diagram 9

System tested and certified by NSF International against NSF/ANSI Standard 53 for the reduction of Asbestos, Atrazine, Benzene, Cyst, Carbofuran, Lead, Lindane, Mercury, P-Dichlorobenzene, Toxaphene & Turbidity; against Standard NSF/ANSI 42 for the reduction of Chlorine Taste and Odour and Nominal Particulate Class I to a capacity of 2,838 Litres (750 gallons).

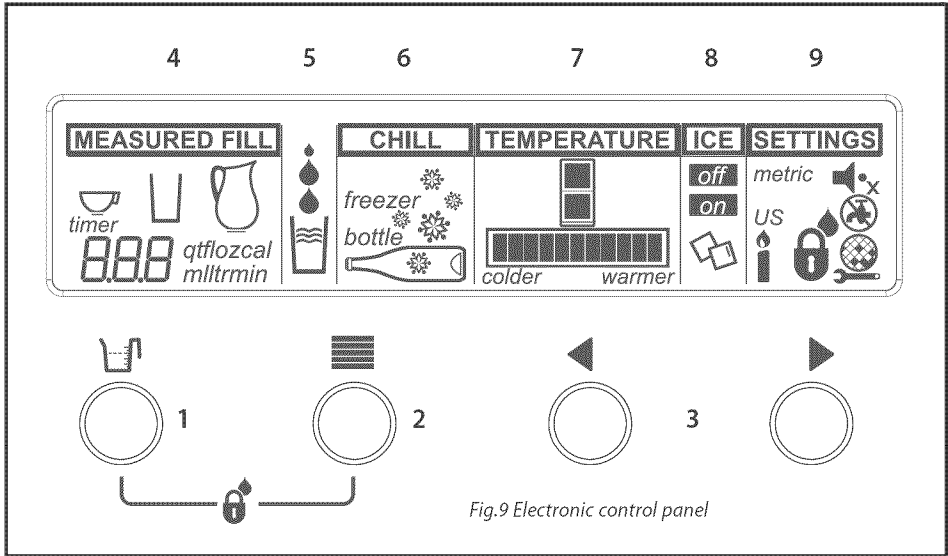

## 8 All about the display

The display screen enables you to view and modify all the features and options on your fridge. For example, you can change the temperature in your fridge or freezer, and select the Freezer Chill function when you want to quickly freeze meat. You may want a measured amount of chilled water when you are cooking, or want to quickly chill a bottle of wine when friends arrive unexpectedly.









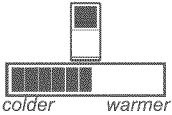

### Keys

For more detailed information on these functions please refer to pages 10 – 17.

	<p><b>1. Measured Fill</b> (see page 13) Enables you to select the amount of water to be dispensed.</p>
	<p><b>2. Main menu</b> Scrolls through the main menu. (Chill, Temperature, Ice and Settings).</p>
	<p><b>3. Arrow keys</b> Scrolls through the settings of each function.</p>

Display features

	<p><b>4. Measured Fill</b> (see page 13) A pre-measured volume of water can be selected and dispensed automatically.</p>
	<p><b>5. Dispensing water</b> (see page 10) Animation shows you water is being dispensed.</p>
	<p><b>6. Chill</b> (see pages 14 – 15)</p> <p><b>Freezer Chill</b> When activated this feature boosts cooling in your freezer, optimising the rate at which your foods are frozen.</p> <p><b>Bottle Chill</b> Your drinks can be chilled more rapidly using this function. An alarm will alert you when they are ready.</p>
	<p><b>7. Temperature</b> (see page 15) The temperature setting can be individually adjusted for each compartment.</p>
	<p><b>8. Ice</b> (see page 11) The ice making function can be turned on or off.</p>
	<p><b>9. Settings/User alerts</b> (see page 16)</p> <p><b>Water conversion</b> Your volume can be displayed as either <b>US</b> or <b>metric</b> units.</p>
	<p><b>Key Silent Mode</b> All key presses can be silenced.</p>
	<p><b>Key and dispenser lock</b> Dispenser lock – disables the buttons and prevents water from being dispensed. Key lock – disables the buttons.</p>
	<p><b>Sabbath Mode</b> Can be activated if necessary (refer to page 16).</p>

## 10 Using your water dispenser

### Dispensing pad

Your water dispenser has been designed for one handed operation. Simply push your glass up against the dispenser pad found at the back of the dispenser area. This pad requires only a gentle press to activate.

Please remember that pressing very hard against the dispensing pad will not make the dispenser operate faster or produce greater quantities of water.

### First use

- After installation, on the first use, allow approximately a one minute delay from when the dispensing pad is pushed until water is dispensed. This will allow the tank to fill completely.
- The  symbol will flash while the water reservoir fills up. Once the reservoir is full, the symbol will stop flashing.
- After you fill the tank for the first time, dispense and discard approximately 3 L or 3 qt to flush the tank out.



### Dispensing

- Unless Measured Fill is selected, water will be dispensed in free-flow mode. (For more information on Measured Fill refer to page 13).
- To dispense water push the dispensing pad gently, using a glass or container.
- When you dispense water, a light will appear above the dispensing area, and on the display screen. The water fill icon  will also appear.
- To stop the flow of water, simply pull your glass away from the dispensing pad.

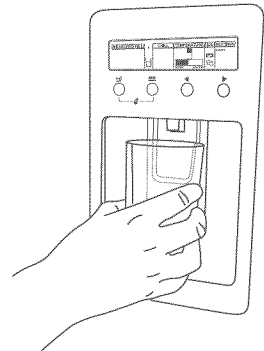

Fig.10 Water dispenser

### **Important!**



*To avoid damage to property or personal injury do not put hands, fingers or objects up the dispenser opening.*

**on**

## Ice maker

Your ice maker is designed to automatically dispense ice until it senses that the bin is full. So the more ice you use, the more it makes. It is even clever enough to sense when there is nothing there to catch the ice.

### First use

- When you first turn your refrigerator on, the ice maker will be off.
- To turn your ice maker on use the  button to scroll to the **ICE** screen. Use the  or  button to turn the ice maker on or off.

**on**

Shows the ice maker is on.

**off**

Shows the ice maker is off.

- If the bin is full, or inserted incorrectly the ice maker will not operate. When the bin is inserted correctly the scoop will be on the right hand side of the bin (refer to Fig.12 on page 12). If the bin is removed the ice maker will not operate.
- Once your ice maker is in operation, discard the first bin of ice cubes. This will flush away any impurities in the water line and ensure that you get the best quality ice. We recommend that you also do this after vacations or extended periods of not using ice.
- We recommend that you turn the ice maker off if:
  - The water supply is to be off for several hours or
  - The ice storage bin is to be removed for a period of time or
  - You are going on holiday/vacation.

### Noises

- If this is your first ice maker, you will hear occasional sounds that may be unfamiliar. They are normal ice making sounds and are not cause for concern.
- The following sounds are normal with the operation of an ice maker:
  - Motor operation (low humming).
  - Running water.
  - Water valve opening and closing (hissing sound).
  - Ice being loosened from tray (cracking).
  - Ice dropping into bin (clunking).

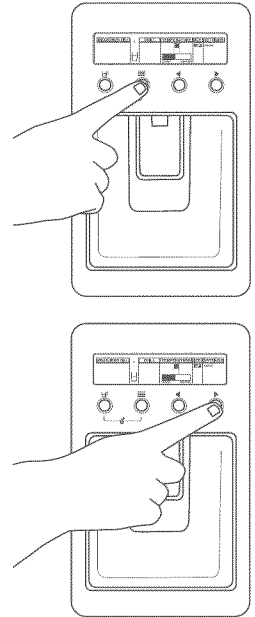

Fig.11 Turning ice maker on

## 12 Using your ice maker

### Information about your ice maker

- Your automatic ice maker will produce approximately eight cubes of ice every 2 – 3 hours, depending on freezer compartment temperature and number of door openings.
- The ice cube tray will fill with water after the freezer has reached the correct temperature. First cubes will normally freeze after several hours.
- When cubes are frozen, they will be ejected from the mould into the ice storage bin.
- Ice making will continue until the storage bin is full.
- Ice making will resume when the ice is used.
- For maximum ice storage, level the stored cubes with the ice scoop.
- Your Ice & Water product comes with a smaller ice bin inside the larger freezer bin. Attached to this is a scoop for the ice.
- If a large amount of ice is required, remove the smaller storage bin and allow ice to fall into the larger bin.
- If ice is not used often, old cubes will become cloudy and taste stale and will shrink. Empty the ice storage bin periodically and wash in lukewarm water. Dry thoroughly and place back.

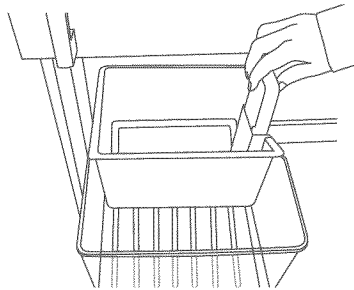

Fig.12 Ice storage bin and scoop  
in correct position

### **Important!**

- *Avoid contact with the moving parts of the ejector mechanism, and do not place your fingers on the automatic ice making mechanism while the refrigerator is plugged in.*
- *Do not use ice cubes that may have become discoloured, usually with a green-blue colour. If such dis-colouration is noted, discard the ice cubes and contact your local authorized service centre.*
- *Ensure the ice maker is connected to the filter and to a drinkable water supply only.*
- *Installation of the water connection to the ice maker must be completed by a qualified service technician (see installation instructions).*

## Measured Fill

One useful feature of your water dispenser is its ability to dispense a pre-measured amount of water. This comes in handy when cooking or preparing drinks.

- Press the  button to highlight the **MEASURED FILL** screen and again to cycle through the preset quantities.

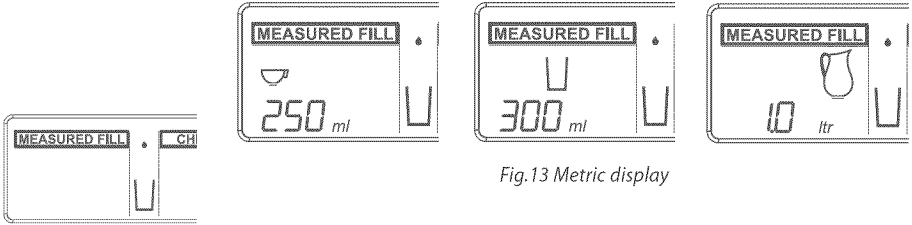

Fig.13 Metric display

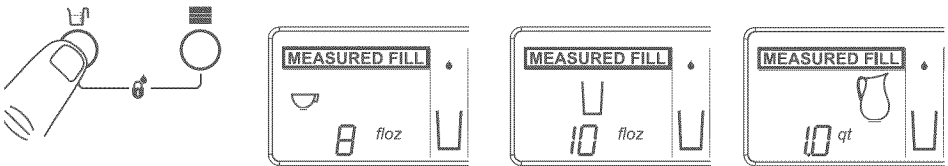







Fig.14 US display

- Push the dispensing pad to receive the pre-selected quantity of chilled water.
- If you stop dispensing part way through your pre-selected quantity the dispenser will remember the remaining quantity to be dispensed for a short time. Simply continue by pressing the pad.
- The  and  buttons can be used to increase or decrease the pre-set measurements in 25 ml, or 1 oz increments, to a maximum of 1 L, or 1 qt.

## Changing the Measured Fill units

The pre-set measurements can be displayed in US imperial or metric units.

The unit setting can be changed by pressing the  button to scroll to the **SETTINGS** screen and pressing the  and  buttons until the desired units are displayed. To return to the Measured Fill option, press the  button.







## 14 Fridge options



### Freezer Chill

We know that the faster food is frozen, the better the overall quality of the food, so we have created the Freezer Chill feature.

The Freezer Chill feature drops the freezer to its coldest temperature for a 12 hour period and then returns to its normal mode. You may wish to use this when freezing a quantity of meat or when you are making frozen desserts.

- To activate, use the  button to scroll to the **CHILL** screen. Then use the  button until  is displayed.
- To deactivate manually, use the  button to scroll to the **CHILL** screen. Then use the  and  buttons until there is no  icon in the **CHILL** screen.

For best results, we recommend that you activate the function approximately 2 hours before it is required. Alternatively, activate it when placing food into the freezer.



### Bottle Chill

This function allows you to chill your beverages in the freezer without the worry of forgetting about them.

When activated Bottle Chill will remind you to remove your bottle by sounding an alarm. The user alarm will continue to sound until any key on the panel is pressed.

The time taken to chill depends on the size of your bottle. Bottle Chill allows you to customise this chill time.





#### Recommended times:

20 minutes – can or small bottle.

25 minutes – wine bottle or similar size beverage.

30 minutes – larger bottle.



If you remove your beverage from the freezer and it is not chilled to your liking, reset the timer to 10 minutes and place the beverage back into the freezer.

- To activate, use the  button to scroll to the **CHILL** screen. Then use the  button until  is displayed.
- Then use the  button to select 10, 15, 20, 25 or 30 minutes as displayed on the left hand side of the screen in the **MEASURED FILL** screen.
- An alarm will sound after the amount of time selected has elapsed.

## Bottle Chill contd...





### ***Important!***

*Do not leave the bottle inside the freezer longer than the time needed for chilling.*

- To deactivate manually, use the  button to scroll to the CHILL screen, then use the  and  buttons until there is no icon in the CHILL screen.

Note: The freezer chill and bottle chill option cannot be used at the same time.

## The temperature of your refrigerator and freezer

- When the refrigerator is first turned on it will take approximately 2 to 3 hours to cool, depending on the humidity and temperature of the environment.
- To adjust the temperature of a compartment, use the  button to scroll to the TEMPERATURE screen, use the  button to select the compartment to change.
- The temperature can then be adjusted using the  button to make the compartment warmer or the  button to make the compartment colder.
- The temperature setting will be indicated on the icon below.

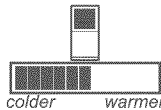



It is important to have your refrigerator set to the correct temperature. Setting it too cold may cause some items in the refrigerator to freeze, and setting it too warm will decrease the storage life of your food.

- For further information on food storage temperatures refer to the food care section in the general Refrigeration & Freezer User Guide.

## 16 Fridge options

### Settings

#### Water unit conversion

- You can change the units your refrigerator uses between US and metric units. To change the units press the  button to scroll to the **SETTINGS** screen option and press one of the  or  buttons until the desired units are displayed.

#### Key Silent Mode







- The Key Silent Mode allows you to silence all key presses.
- It can be activated or deactivated by holding the  button for four seconds.

When Key Silent Mode is on  will appear.

When this function is off no symbol will appear.

Note: Faults, Bottle Chill timer and the door alarm will still sound when the refrigerator is set on Key Silent Mode.

#### Key and dispenser lock

- The dispenser lock disables the buttons and prevents water from being dispensed.
- Key lock disables the buttons.
- Activate by holding down both the  button and the  button together.
- After 2 seconds  icon will appear indicating dispenser lock is activated.
- After 2 more seconds  icon will appear indicating key lock is activated.
- To de-activate, hold down both the  button and the  button together for 2 seconds.

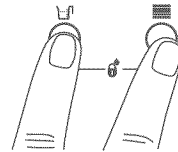





Fig.15 Key and dispenser lock

#### Sabbath Mode

- In Sabbath Mode alarms, lights and displays are deactivated.
- Sabbath Mode can be activated or deactivated by holding down the ,  and  button for 4 seconds.

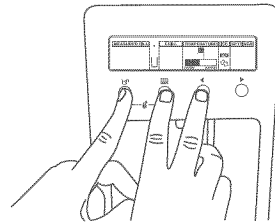

Fig.16 Sabbath Mode

## Settings

### Once in Sabbath Mode:

- The interior light will not turn on when the refrigerator is opened.
- The door alarm will not operate.
- The display will not be illuminated.
- Electronic control panel will not work.

Note: If power is turned off the refrigerator will automatically continue in Sabbath Mode once power is restored. Sabbath Mode will automatically de-activate after 80 hours.

## User warnings

Your refrigerator is clever enough to diagnose it's own problems. It will alert you when there is a fault.



### No water

The no water icon  will appear when the water supply to the refrigerator is interrupted. Please refer to the Trouble shooting checklist (refer to pages 21 – 22).



### Filter reset

The filter reset icon  will appear when the water filter needs changing. This will flash when dispensing water. To change the filter and reset the filter icon refer to pages 18 – 19.



### Fault

- In the unlikely event a fault occurs the  icon appears on the front of the display and a fault code will be displayed on the left in the **MEASURED FILL** screen.
- When the door is open the refrigerator fault alarm will sound. To silence this press any button on the display.
- Please take note of the fault code and contact our Customer Care Centre. Details of Customer Care phone numbers can be found in the back of this book.

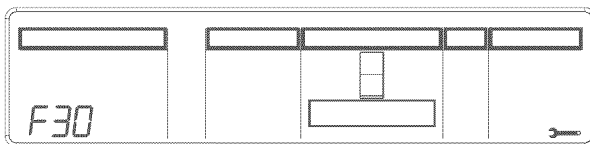



Fig.17 Fault code display

All the water to your fridge is filtered to remove impurities through a cartridge located in a position of your choice outside the refrigerator. Of course, this will need changing approximately every 6 months or up to 2800 L depending on the quality of the incoming water and how much you use the dispenser.

- There is a replacement indicator  icon on the control panel which will appear when the filter needs replacing. It will flash, when dispensing water, as a reminder.
- Replacement cartridges are available from your authorised Fisher and Paykel Dealer. The details of the replacement cartridge are on the label on the cartridge.

### Changing the water filter cartridge

- 1 Grasp and firmly twist the cartridge in an anticlockwise direction (to the left when installed in the recommended orientation) as shown in Diagram 1.
- 2 Pull the cartridge away from the filter head (down when installed in the recommended orientation) as shown in Diagram 2.
  - It is not unusual for a few drops of water to be present when filter is removed.
- 3 Discard old filter.
- 4 Filter installation:
  - Remove protective cap on spigot on head.
  - Push the cartridge up towards filter head while rotating it in a clockwise direction (to the right when installed in the recommended orientation) as shown in Diagram 3.
- 5 Reset filter indicator icon on the display (this will set to remind you when the filter is due to be replaced again). Refer to page 19.
- 6 Dispense 5 L / 5 qt to flush the cartridge, removing trapped air and harmless carbon fines.
- 7 A few drips may appear out of the dispenser over the next few days as the remaining trapped air is cleared.

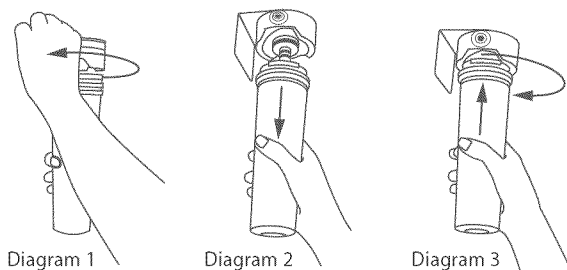





Fig.18 Changing the water filter cartridge

## To reset filter indicator

### ***Important!***





*We recommend the water filter is used from installation.*

*Do not reset monitor before filter is changed or filter monitoring will be inaccurate.*

- Press and hold  and  buttons for 4 seconds to reset the filter indicator.
- If present the  icon in the **SETTINGS** screen will disappear when reset.

## To disable filter indicator

Note: if disabled, you will not be reminded to change your filter.

- When no filter is to be fitted, you can disable the filter indicator.
- Press and hold ,  and  buttons for 4 seconds to turn this feature off/on.
- When activated or deactivated the  icon will flash and on or off will be displayed in the **MEASURED FILL** screen.
- We recommend that you do not disable the filter indicator if you have a filter fitted to the connection.

### ***Important!***

- *To avoid serious illness or death, do not use the water filter where water is unsafe or of unknown quality without adequate disinfection before or after use of filter.*
- *The water filter cartridge needs to be changed when the filter indicator icon flashes on the interface panel.*
- *We recommend the water filter cartridge is replaced when the  icon flashes. This will happen every 6 months or 2800 L.*
- *If the water filtration system has been allowed to freeze, replace filter cartridge.*
- *If system has not been used for several months and water has an unpleasant taste or odour, flush system by dispensing 3 L or 3 qt of water. If unpleasant taste or odour persists, change filter cartridge.*

## 20 Measured Fill Calibration

### Measured Fill Calibration

The accuracy of your Measured Fill function can be affected by variations in the incoming water pressure. The Measured Fill Calibration Mode allows you to fine-tune the amount of water dispensed from the preselected volumes on your cabinet.

The calibration mode is worked out as a percentage. You can measure the amount the refrigerator is under filling or over filling and increase or decrease the calibration to get the exact amount you want.

#### To assess whether the Measured Fill function is under or over filling:

- Press the **MEASURED FILL** button until 1 L (1 qt) is displayed.
- Dispense this amount into a measuring jug.
- Estimate the amount of water that has been dispensed into the jug.  
eg. 975 ml = under filling by 25 mls or 31 floz = under filling by 1 floz

#### To calculate the Calibration factor:

- Transfer the difference into a percentage.  
eg.  $1000/975 = 1.03 = 103\%$  or  $32/31 = 1.03 = 103\%$
- Enter the Calibration mode by pressing and holding the **⏏** and **◀** buttons together for 4 seconds.
- 100CAL will be displayed.
- The number displayed is a percentage. Adjust this accordingly using the **◀** and **▶** buttons.  
eg. 100CAL = 103CAL
- Press the **MEASURED FILL** button to confirm your selection.

Please note:

- The Measured Fill function has an accuracy of +/-5% at the time of calibration.
- The accuracy of your calibration will of course be subject to the accuracy of your measuring device and method.

### Calibration quick reference guides

#### Metric





Actual amount of water received	Under filled	Difference from 1 L	Adjust display to read (calibration factor)
Underfilling – you dispense 1 L but the amount of water you receive is actually less than 1 L			
975 ml	25 ml	3%	103 CAL
950 ml	50 ml	5%	105 CAL
Overfilling – you dispense 1 L but the amount of water you receive is actually more than 1 L			
1025 ml	25 ml	2%	98 CAL
1050 ml	50 ml	5%	95 CAL

#### US

Actual amount of water received	Under filled	Difference from 32 floz	Adjust display to read (calibration factor)
Underfilling – you dispense 1 qt but the amount of water you receive is actually less than 1 qt			
31 floz	1 floz	3%	103 CAL
30 floz	2 floz	7%	107 CAL
Overfilling – you dispense 1 qt but the amount of water you receive is actually more than 1 qt			
33 floz	1 floz	3%	97 CAL
34 floz	2 floz	6%	94 CAL

Problem	Possible Causes	What to Do
<b>Ice maker makes unfamiliar sounds or seems too loud.</b>	Normal ice maker operation.	Refer to ice maker noises (see page 11).
<b>Automatic ice maker does not work.</b>	Ice maker has not been switched on.	Switch on ice maker (see page 11).
	Bin is in the wrong way or no bin at all.	Place bin so scoop is on the right side. Ice bin sits directly under ice maker on top left side of freezer.
	Water supply turned off or not connected.	Connect water supply.
	Freezer compartment not working.	Contact Customer Care.
	Water pressure too low.	Check water pressure.
	Water line kinked/squashed.	Check water line for kinks/squashing.
	Filter clogged.	Water filter may need replacing.
<b>Ice cubes have odour/taste.</b>	Unsealed packages may be transmitting odour/taste.	Old cubes need to be discarded. Ensure food packaging is sealed.
	Interior of freezer needs cleaning.	Ice storage bin needs to be emptied and washed.  Clean refrigerator (refer to cleaning instructions in Refrigerator & Freezer User Guide).
	Poor taste from incoming water.	Filter may need changing. A filter may need to be installed.
<b>Slow ice cube freezing.</b>	Door may have been left ajar.	Close door.
	Freezer compartment too warm.	Turn temperature to a colder setting (refer to page 15).

## 22 Trouble shooting

Problem	Possible Causes	What to Do
Water has poor taste/odour.	Refrigerator not used for an extended period.	Dispense 3 L or 3 qt water so fresh water supply is replenished.
Water dispenser does not work and/or  icon flashing.	Water supply turned off or not connected.	Turn water on. Press dispenser for 2 mins to remove trapped air from water line and to fill the water system.
	Supply line may be blocked. On first installation there may be air in water system.	Check supply for kinks or leaks. To remove air, run a litre or a quart of water through the dispenser.
	Filter may be blocked and need replacing.	Replace filter (see back of this booklet for Customer Care contact details).
	Dispenser lock activated.	Hold down the  and  button for 2 seconds.
	Water frozen in tank.	Increase temperature to a warmer setting in fresh food compartment and freezer.
Water in first glass is warm.	Water dispenser not used for extended period.	Allow 24 hrs for water to cool to set temperature.
	Tank capacity used recently.	Allow water time to cool.
Filter warning light  is flashing.	Filter needs replacing.	Replace filter as soon as possible (see pages 18 – 19).
Wet ice/ice clumping.	Low water pressure.	Check water pressure.
	Filter blocked.	Replace filter (see pages 18 – 19).
	Long freezer door openings High ambient temperature Ice bin left out of freezer compartment a length of time Ice will stick together over time.	Gently tap ice with scoop to unstick or, if large clumps occur, empty ice bin and make new ice.
Measured Fill amount of water is inaccurate.	Measured Fill needs recalibration.	Recalibrate (see page 20).

## Water dispenser pad and interface

- We have incorporated a Dispenser and Key Lock function in your refrigerator to make cleaning easier. This will help you to avoid accidental water dispensing while you clean.
- Clean the pad and interface panel with a soft damp cloth.

## Automatic ice dispenser

- We do not recommend you clean the ice maker componentry, but it is important to clean the bins occasionally.
- The storage bin should be cleaned regularly and the old ice in the bottom of the bin discarded.
- Wash bin in lukewarm water. Dry thoroughly and replace.
- When replacing the bin ensure that the scoop is on the right hand side.

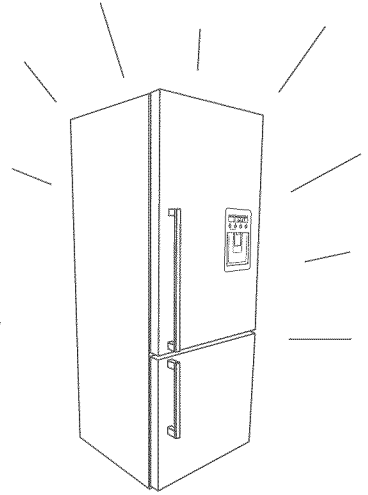

For further cleaning instructions please refer to the general Refrigeration & Freezer User Guide.

## On vacation/holiday

- Switch the ice maker to off on the interface panel (see page 11).
- Shut off the water supply to the refrigerator.
- On return turn on the water supply to the refrigerator.
- Dispense 3 L or 3 qt of water and discard to ensure the tank is refilled with fresh water.
- Turn on the ice maker (see page 11).
- Throw away the first bin of ice cubes.

### Before you call for service or assistance ...

Check the things you can do yourself. Refer to the installation instructions and your user guide and check that:

- 1 Your product is correctly installed.
- 2 You are familiar with its normal operation.

If after checking these points you still need assistance please refer to the following...

### In New Zealand If You Need Assistance...\*

Call your Fisher & Paykel retailer who is trained to provide information on your appliance, or if we can be of any further help, please contact our Customer Care Centre,

**Toll Free:** 0800 FP CARE or 0800 37 2273

**Fax:** (09) 273 0656

**Email:** [customer.care@fp.co.nz](mailto:customer.care@fp.co.nz)

**Postal Address:** Fisher & Paykel Appliances Limited, PO Box 58732 Greenmount, Auckland

### If you need service...\*

Fisher & Paykel has a network of independent Fisher & Paykel AUTHORISED SERVICE CENTRES whose fully trained technicians can carry out any service necessary on your appliance. Your dealer or our Customer Care Centre can recommend an AUTHORISED SERVICE CENTRE in your area.

### In Australia If You Need Assistance...\*

Please call our Fisher & Paykel Customer Care Centre.

**Toll Free:** 1300 650 590

**Fax:** (07) 3826 9298

**Email:** [customer.care@fp.com.au](mailto:customer.care@fp.com.au)

**Postal Address:** Fisher & Paykel Appliances Limited, PO Box 798, Cleveland, QLD4163

### If you need service...\*

Fisher & Paykel Australia Pty Ltd has a network of independent Fisher & Paykel AUTHORISED CUSTOMER SERVICE CENTRES whose fully trained technicians can carry out any service necessary on your appliance. Our Customer Care Centre can recommend an AUTHORISED SERVICE CENTRE in your area.

### In United Kingdom If You Need Assistance...\*

**Phone:** (0845) 066 2200

**Fax:** (0845) 331 2360

**Email:** [customer.care@fisherpaykel.co.uk](mailto:customer.care@fisherpaykel.co.uk)

**Postal Address:** Fisher & Paykel Appliances Limited, Pheasant Oak Barn, Hob Lane, Balsall Common, CV7 7GX

## In Ireland If You Need Assistance...\*

**Phone:** 01800 625 174

**Fax:** 01800 635 012

**Email:** [customer.care@fisherpaykel.ie](mailto:customer.care@fisherpaykel.ie)

**Postal Address:** Fisher & Paykel Appliances Limited, Unit 3, North Park, North Road, Dublin 11

## For the Rest of the World...\*

Call your Fisher & Paykel retailer/dealer from whom you purchased the product. They are trained to provide information on your appliance. If we can be of any further help, please contact us on:

**Phone:** +64 9 273 0660

**Fax:** +64 9 273 0580

**Email:** [international.enquiries@fp.co.nz](mailto:international.enquiries@fp.co.nz)

**Postal Address:** Fisher & Paykel Appliances Limited, PO Box 58550, Greenmount, Auckland, New Zealand

## In Europe If You Need Assistance...\*

Please refer to website for regional service providers.

[www.fisherpaykel.com](http://www.fisherpaykel.com)

## In USA If You Need Assistance...\*

**Toll Free:** 1 888 9 FNP USA or 1 888 367 872

**Fax:** 949 790 8913

**Email:** [customer.care@fisherpaykel.com](mailto:customer.care@fisherpaykel.com)

**Postal Address:** Fisher & Paykel Appliances Inc, 5900 Skylab Road, Huntington Beach, CA 92647, USA

**Feel free to contact us at our website on  
[www.fisherpaykel.com](http://www.fisherpaykel.com)**

\*If you call or write, please provide: name, address, model number, serial number, date of purchase and a description of the problem. This information is needed in order to better respond to your request for assistance.

## Product Details

Fisher & Paykel Appliances Ltd

**Model/Serial No.**

**Date of Purchase** \_\_\_\_\_ **Purchaser** \_\_\_\_\_

**Dealer** \_\_\_\_\_ **Suburb** \_\_\_\_\_

**Town** \_\_\_\_\_ **Country** \_\_\_\_\_

State of California  
Department of Health Services  
Water Treatment Device  
Certificate Number

06 - 1806

Date Issued: July 18, 2006

---

---

**Trademark/Model Designation**

Fisher & Paykel 836860

**Replacement Elements**

836848

---

---

**Manufacturer: Cuno Incorporated**

The water treatment device(s) listed on this certificate have met the testing requirements pursuant to Section 116830 of the Health and Safety Code for the following health related contaminants:

**Microbiological Contaminants and Turbidity**

Cysts

Turbidity

**Organic Contaminants**

Atrazine

Benzene

Carbofuran

Lindane

p-dichlorobenzene

Toxaphene

**Inorganic/Radiological Contaminants**

Asbestos

Lead

Mercury

---

**Rated Service Capacity:** 750 gal

**Rated Service Flow:** 0.78 gpm

**Conditions of Certification:**

Do not use where water is microbiologically unsafe or with water of unknown quality, except that systems certified for cyst reduction may be used on disinfected waters that may contain filterable cysts.

# Performance Data Sheet For Fisher & Paykel Filter System Model: 836860

## Replacement Cartridge: 836848

This system has been tested according to NSF/ANSI 42 and 53 for the reduction of the substances listed below. The concentration of the substances in water entering the system was reduced to a concentration less than or equal to the permissible limit for water leaving the system as specified in NSF/ANSI 42 & 53.



System tested and certified by NSF International against NSF/ANSI Standard 53 for the reduction of Asbestos, Atrazine, Benzene, Cyst, Carbofuran, Lead, Lindane, Mercury, P-Dichlorobenzene, Toxaphene and Turbidity; against Standard NSF/ANSI 42 for the reduction of Chlorine Taste and Odor and Nominal Particulate Class I.

Note that while the testing was performed under standard laboratory conditions, actual performance may vary.

To a capacity of 2,838 liters (750 gallons)

Standard 53: Health Effects								
Substance	USEPA MCL	Influent Challenge concentration (mg/L)	Influent Average	Effluent		% Reduction		Min. Required Reduction
				Average	Maximum	Average	Maximum	
Turbidity	1 NTU**	11±1 NTU**	10.7 NTU**	0.31 NTU**	0.49 NTU**	97.09%	95.20%	0.5 NTU**
Cysts	99.95% reduction	Minimum 50,000 #/L	166500 #/L	<1 #/L	<1 #/L	<99.99%	<99.99%	>99.95%
Asbestos	99% reduction	10 <sup>7</sup> to 10 <sup>8</sup> fibers/L; fibers greater than 10 um in length	155 MF/L	<1 MF/L	<1 MF/L	<99.99%	<99.99%	>99%
Lead @ pH 6.5	0.015 mg/L	0.15mg/L +10%	0.153 mg/L	<0.001 mg/L	<0.001 mg/L	99.35%	99.29%	0.010 mg/L
Lead @ pH 8.5	0.015 mg/L	0.15mg/L +10%	0.150 mg/L	<0.001 mg/L	<0.001 mg/L	99.33%	99.29%	0.010 mg/L
Mercury @ pH 6.5	0.002 mg/L	0.006mg/L ±10%	0.006 mg/L	0.0003 mg/L	0.0005 mg/L	95.70%	90.91%	0.002 mg/L
Mercury @ pH 8.5	0.002 mg/L	0.006mg/L ±10%	0.006 mg/L	0.0008 mg/L	0.0015 mg/L	86.22%	75.31%	0.002 mg/L
Atrazine	0.003 mg/L	0.009mg/L ±10%	0.009 mg/L	<0.002 mg/L	<0.002 mg/L	76.99%	75.31%	0.003 mg/L
Benzene	0.005 mg/L	0.015mg/L ±10%	0.014 mg/L	0.0006 mg/L	0.0011 mg/L	95.71%	92.14%	0.005 mg/L
Carbofuran	0.04 mg/L	0.08mg/L ±10%	0.081 mg/L	<0.001 mg/L	<0.001 mg/L	98.74%	98.46%	0.04 mg/L
p-dichlorobenzene	0.075 mg/L	0.225mg/L ±10%	0.208 mg/L	<0.0005 mg/L	<0.0005 mg/L	99.76%	99.74%	0.075 mg/L
Lindane	0.0002 mg/L	0.002mg/L +10%	0.002 mg/L	0.000025 mg/L	0.00007 mg/L	98.72%	96.50%	0.0002 mg/L
Toxaphene	0.003 mg/L	0.015±10%	0.015 mg/L	<0.001 mg/L	<0.001 mg/L	92.97%	91.67%	0.003 mg/L
Standard 42: Aesthetic Effects								
Substance	USEPA MCL	Influent Challenge concentration (mg/L)	Effluent Average	Effluent		% Reduction		Min. Required Reduction
				Average	Maximum	Average	Maximum	
Chlorine Taste & Odor	~	2.0mg/L +10%	1.88 mg/L	0.051366364 mg/L	0.06 mg/L	97.26%	96.84%	>50%
Nominal Particulate*	~	at least 10,000 particales/mL	5,700,000 #/ml	30,583 #/ml	69,000 #/ml	99.95%	98.94%	>85%

\* Measurement in Particles/ml. Particles used were 0.5 - 1 microns.

\*\*NTU = Nephelometric Turbidity Units

### Operation Specifications

Water pressure	172-827 kPa (25-120psi)
Water temperature	0.6-38°C (33-100°F)
Service flow	2.9 lpm (.78 gpm)
Filter capacity	2,838 liters (750gallons)

Systems must be installed and operated in accordance with manufacturer's recommended procedures and guidelines. Follow any and all local plumbing codes and requirements. Some local codes may require the use of a licensed plumber or a certified installer when disrupting a potable water line.

**Important: Failure to follow instructions may result in voidance of warranty.**

**Important: Do not use with water that is microbiologically unsafe or of unknown quality without adequate disinfection before or after the system.** Systems certified for cyst reduction may be used on disinfected water may contain filterable cysts.

EPA Establishment Number 070595-MN-001

**Install on cold water line only.**

**IMPORTANT: Change the filter cartridge at least every 6 months.**

**CAUTION:** To reduce the risks associated with water leakage, which, if not avoided, may result in property damage - check with your plumbing professional to verify that water pressure is less than 827 kPa (120 psi).

For estimated cost of replacement element, please call 1-888-936-7872 or contact your local appliance distributor or dealer.

# Fisher & Paykel

Manufactured by : CUNO Incorporated, a 3M Company  
1000 Apollo Road  
Eagan, MN 55121

Copyright © Fisher & Paykel 2006. All rights reserved.  
The product specifications in this booklet apply to the specific products and models described at the date of issue. Under our policy of continuous product improvement, these specifications may change at any time. You should therefore check with your Customer Care Centre to ensure this booklet correctly describes the product currently available.

**[www.fisherpaykel.com](http://www.fisherpaykel.com)**

NZ AU US CA UK AE HK SG MY

Ice & Water refrigerator

Installation instructions and user guide

Published: 10/2006

Part No. 814940B