



Charcoal Grill Owners Guide

Performer Smart / Performer Premium Smart 22in/57cm

Keep this Owner's Manual for future reference, thoroughly read through it, and if you have any questions please contact us today.



REGISTER TODAY

Register your grill and receive special content to make you the ultimate backyard hero.

Scan the QR Code or register online at weber.com

Do not discard. This owner's guide contains important product dangers, warnings, and cautions. For assembly instructions, refer to the assembly guide. Do not use the grill indoors!

Visit weber.com, select your country of origin, and register your grill today.

SAFETY

Failure to follow the DANGERS, WARNINGS, and CAUTIONS contained in this Owner's Guide may result in serious bodily injury or death, or may result in a fire or an explosion causing damage to property. Please read all safety information contained in this Owner's Guide before operating this barbecue.

DANGERS

- Do not use indoors! This grill is designed for outdoor use in a well-ventilated area and is not intended for and should never be used as a heater. If used indoors, toxic fumes will accumulate and cause serious bodily injury or death.
- Do not use in a garage, building, breezeway, or any other enclosed area.
- Do not use gasoline, alcohol, or other highly volatile fluids to ignite charcoal. If using charcoal starter fluid (not recommended), remove any fluid that may have drained through the bowl vents before lighting the charcoal.
- Do not add charcoal starter fluid or charcoal impregnated with charcoal lighter fluid to hot or warm charcoal. Cap starter fluid after use, and place a safe distance away from the grill.
- Keep the cooking area clear of flammable vapor and liquids, such as gasoline, alcohol, etc., and combustible material.

WARNINGS

- Do not use this grill unless all parts are in place. This grill must be properly assembled according to the assembly instructions. Improper assembly may be dangerous.
- Never use grill without the ash catcher installed.
- Do not use this grill under any overhead combustible construction.
- The use of alcohol, prescription, or non-prescription drugs may impair the consumer's ability to properly assemble or safely operate the grill.
- Exercise caution when operating your grill. It will be hot during cooking or cleaning, and should never be left unattended.
- This grill will become very hot, do not move it during operation.
- Keep children and pets away.
- This WEBER grill is not intended to be installed in or on recreational vehicles and/or boats.
- Do not use this grill within two feet (60cm) of any combustible material. Combustible materials include, but are not limited to, wood or treated wood decks, patios, and porches.
- Keep the grill on a secure, level surface at all times, clear of combustible material.

- Do not place grill on glass or a combustible surface.
- Do not use grill in high winds.
- Do not wear clothing with loose flowing sleeves while lighting or using the grill.
- Never touch the cooking or charcoal grate, ashes, charcoal, or the grill to see if they are hot.
- Extinguish charcoal when finished cooking. To extinguish, close bowl vent and lid damper and place lid on bowl.
- Use heat-resistant barbecue mitts or gloves while cooking, adjusting air vents (dampers), adding charcoal, and handling thermometer or lid.
- Use proper tools, with long, heat-resistant handles.
- Always put charcoal on top of the charcoal (lower) grate. Do not put charcoal directly in the bottom of the bowl.
- Do not lean on or overload the end of the table.
- Do not use the TUCK-AWAY lid holder as a handle to lift or move the grill.
- Do not hang the lid on the bowl handle.
- Never dump hot charcoal where it might be stepped on or be a fire hazard. Never dump ashes or charcoal before they are fully extinguished.
- Do not store grill until ashes and charcoal are fully extinguished.
- Do not remove ashes until all charcoal is completely burned out and fully extinguished and grill is cool.
- Keep electrical wires and cords away from the hot surfaces of the grill and away from high traffic areas.
- Do not hang the lid on the bowl handle.
- Do not use the TUCK-AWAY lid holder as a handle to lift or move the grill.
- WARNING!** Do not use the grill in a confined and/or habitable space e.g. houses, tents, caravans, motor homes, boats. Danger of carbon monoxide poisoning fatality.
- This appliance is not intended for use by persons (including children) with reduced physical, sensory or mental capabilities, or lack of experience and knowledge, unless they have been given supervision or instruction concerning use of the appliance by a person responsible for their safety.
- Keep electrical wires and cords away from the hot surfaces of the grill and away from high traffic areas so as not to cause a tripping hazard.
- Use this grill only as described in this manual. Misuse may cause fire, electric shock or injury.
- This appliance should only be connected to a grounded outlet. Do not use plug adapters. If an extension cord is needed, only use a 14-gauge cable with a grounded plug, suitable for use with outdoor appliances. The maximum length for the extension cord is 4 meters (13 feet). Keep the extension cord as short as possible. Examine the extension cord before use and replace if damaged. To minimize the risk of property damage and/or personal injury, do not use an extension power-supply cable unless it conforms to the specifications listed in this manual.
- Inspect the power cord and plug regularly for any signs of damage. Do not operate appliance with damaged cord or plug.
- Do not operate the unit if the electrical outlet is damaged.
- Always unplug the grill by pulling from the plug. Do not pull from the cord.
- The food temperature probes are very sharp and can become hot when in use. Use care when handling the probes to avoid the risk of injury.

Serial Number

Write your barbecue's serial number in the box above for future reference. The serial number is on the barbecue's data label.

- If using the WEBER CONNECT app to monitor the operation of the barbecue, make sure that all safety precautions otherwise applicable to the operation of the grill have been observed prior to using the grill. Someone familiar with the operation of the grill must be in close proximity of the grill in order to address any emergencies that could arise. Do not leave the grill unattended.
- Make sure all electrical connections are kept dry and off of the ground.
- When connecting this appliance to a power supply, ensure that the supply voltage corresponds with the voltage rating marked on the appliance label.
- Use proper tools, with long, heat-resistant handles.
- Always unplug the grill from the outlet when not in use and before cleaning. Allow the grill to cool before performing maintenance.

CAUTIONS

- Do not use water to control flare-ups or to extinguish charcoal.
- Lining the bowl with aluminum foil will obstruct the air flow. Instead, use a drip pan to catch drippings from meat when cooking using the indirect method.
- Grill brushes should be checked for loose bristles and excessive wear on a regular basis. Replace brush if any loose bristles are found on cooking grate or brush. WEBER recommends purchasing a new stainless steel bristle grill brush at the beginning of every spring.

CALIFORNIA PROPOSITION 65

- WARNING:** Combustion byproducts produced when using this product contain chemicals known to the state of California to cause cancer, birth defects, or other reproductive harm.
- WARNING:** This product can expose you to chemicals including nickel, which is known to the state of California to cause cancer. For more information go to www.P65Warnings.ca.gov.

ADDITIONAL WARNINGS

- Do not use the TUCK-AWAY lid holder as a handle to lift or move the grill.

WARRANTY

Limited Warranty

Thank you for purchasing a WEBER product. Weber-Stephen Products LLC, 1415 S. Roselle Road, Palatine, Illinois 60067 ("WEBER") prides itself on delivering a safe, durable, and reliable product. This is WEBER's Limited Warranty ("Warranty") provided to you at no extra charge. It contains the information you will need to have your WEBER product repaired in the unlikely event of a failure or defect. Pursuant to applicable laws, the customer has several rights in case the product is defective. Those rights include supplementary performance or replacement, abatement of the purchasing price, and compensation. These and other statutory rights remain unaffected by this warranty provision. In fact, this warranty grants additional rights to the Owner that are independent from statutory warranty provisions.

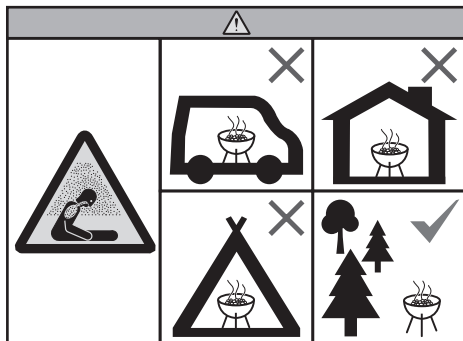

8659405

enUS

12/22/25



WARRANTY

WEBER'S LIMITED WARRANTY

WEBER warrants, to the purchaser of the WEBER product (or in the case of a gift or promotional situation, the person for whom it was purchased as a gift or promotional item) ("Owner"), that the WEBER product is free from defects in material and workmanship for the period(s) of time specified below when assembled and operated in accordance with the accompanying Owner's Manual, normal wear and tear excluded. (Note: If you lose or misplace your WEBER Owner's Manual, a replacement is available online at www.weber.com.) WEBER agrees within the framework of this warranty to repair or replace the part that is defective in material or workmanship subject to the limitations, and exclusions listed below. TO THE EXTENT ALLOWABLE BY APPLICABLE LAW, THIS WARRANTY IS EXTENDED ONLY TO THE ORIGINAL PURCHASER AND IS NOT TRANSFERABLE TO SUBSEQUENT OWNERS, EXCEPT IN THE CASE OF GIFTS AND PROMOTIONAL ITEMS AS NOTED ABOVE.

WEBER stands by its products and is happy to provide you with the Warranty described for material defects in the grill or its relevant components, normal wear and tear excepted.

- 'Normal wear and tear' includes cosmetic and other immaterial deterioration that may come with ownership of your grill over time, such as surface rust, dents / scratches, etc.

However, WEBER will honor this Warranty for the grill or its relevant components where damage or dysfunction results from a material defect.

- 'Material defect' includes rust through or burn through of certain parts, or other damage or failure inhibiting your ability to safely / properly use your grill.

OWNER'S RESPONSIBILITIES UNDER THIS WARRANTY

To ensure trouble-free warranty coverage, it is important (but it is not required) that you register your WEBER product online at www.weber.com. Please also retain your original sales receipt and/or invoice. Registering your WEBER product confirms your warranty coverage and provides a direct link between you and WEBER in case we need to contact you. If you have not had time to register your grill before calling for Warranty service, please have the following information available when you do call:

Name – Address – Phone Number – Email – Serial Number – Purchase Date – Purchase Dealer – Model – Color – Primary Issue

The above warranty only applies if the Owner takes reasonable care of the WEBER product by following all assembly instructions, usage instructions, and preventative maintenance as outlined in the accompanying Owner's Manual, unless the Owner can prove that the defect or failure is independent of non-compliance with the above mentioned obligations. If you live in a coastal area, or have your product located near a pool, maintenance includes regular washing and rinsing of the exterior surfaces as outlined in the accompanying Owner's Manual.

WARRANTY HANDLING / EXCLUSION OF WARRANTY

If you believe that you have a part which is covered by this Warranty, please contact WEBER Customer Service using the contact information on our website (www.weber.com, or such country-specific website to which Owner may be redirected). WEBER will, upon investigation, repair or replace (at its option) a defective part that is covered by this Warranty. In the event that repair or replacement are not possible, WEBER may choose (at its option) to replace the grill in question with a new grill of equal or greater value. WEBER may ask you to return parts for inspection, shipping charges to be pre-paid by owner. When you contact Customer Service, please have the following information available:

Name – Address – Phone Number – Email – Serial Number – Purchase Date – Purchase Dealer – Model – Color – Primary Issue

This WARRANTY lapses if there are damages, deteriorations, discolorations, and/or rust for which WEBER is not responsible caused by:

- Abuse, misuse, alteration, modification, misapplication, vandalism, neglect, improper assembly or installation, and failure to properly perform normal and routine maintenance;
- Insects (such as spiders) and rodents (such as squirrels), including but not limited to damage to burner tubes and/or gas hoses;
- Exposure to salt air and/or chlorine sources such as swimming pools and hot tubs/spas;
- Severe weather conditions such as hail, hurricanes, earthquakes, tsunamis or surges, tornadoes or severe storms.
- Acid rain and other environmental factors.

Using third party parts will not void this Warranty. However, any parts that are used and/or installed on your WEBER product that are not genuine WEBER parts are not covered by this Warranty. In addition, any damages that result from the use and/or installation of parts on your WEBER product that are not genuine WEBER parts are not covered by this Warranty. Any conversion of a gas grill not authorized by WEBER and performed by a WEBER authorized service technician will void this Warranty.

PRODUCT WARRANTY PERIODS

Bowl and Lid:
10 years, rust through/burn through

ONE-TOUCH cleaning system:
5 years, rust through/burn through

Stainless steel components:
5 years, rust through/burn through

Plastic components:
5 years, excluding fading or discoloration

Electrical components:
3 years

All remaining parts:
2 years

DISCLAIMERS

APART FROM THE WARRANTY AND DISCLAIMERS AS DESCRIBED IN THIS WARRANTY STATEMENT, THERE ARE EXPLICITLY NO FURTHER WARRANTY OR VOLUNTARY DECLARATIONS OF LIABILITY GIVEN HERE WHICH GO BEYOND THE STATUTORY LIABILITY APPLYING TO WEBER. THE PRESENT WARRANTY STATEMENT ALSO DOES NOT LIMIT OR EXCLUDE SITUATIONS OR CLAIMS WHERE WEBER HAS MANDATORY LIABILITY AS PRESCRIBED BY STATUTE.

NO WARRANTIES SHALL APPLY AFTER THE APPLICABLE PERIODS OF THIS WARRANTY. NO OTHER WARRANTIES GIVEN BY ANY PERSON, INCLUDING A DEALER OR RETAILER, WITH RESPECT TO ANY PRODUCT (SUCH AS ANY "EXTENDED WARRANTIES"), SHALL BIND WEBER. THE EXCLUSIVE REMEDY OF THIS WARRANTY IS REPAIR OR REPLACEMENT OF THE PART OR PRODUCT.

IN NO EVENT UNDER THIS WARRANTY SHALL RECOVERY OF ANY KIND BE GREATER THAN THE AMOUNT OF THE PURCHASE PRICE OF THE WEBER PRODUCT SOLD.

YOU ASSUME THE RISK AND LIABILITY FOR LOSS, DAMAGE, OR INJURY TO YOU AND YOUR PROPERTY AND/OR TO OTHERS AND THEIR PROPERTY ARISING OUT OF THE MISUSE OR ABUSE OF THE PRODUCT OR FAILURE TO FOLLOW INSTRUCTIONS PROVIDED BY WEBER IN THE ACCOMPANYING OWNER'S MANUAL.

PARTS AND ACCESSORIES REPLACED UNDER THIS WARRANTY ARE WARRANTED ONLY FOR THE BALANCE OF THE ABOVE MENTIONED ORIGINAL WARRANTY PERIOD(S).

THIS WARRANTY APPLIES TO PRIVATE SINGLE FAMILY HOME OR APARTMENT USE ONLY AND DOES NOT APPLY TO WEBER GRILLS USED IN COMMERCIAL, COMMUNAL OR MULTI-UNIT SETTINGS SUCH AS RESTAURANTS, HOTELS, RESORTS, OR RENTAL PROPERTIES. WEBER MAY FROM TIME TO TIME CHANGE THE DESIGN OF ITS PRODUCTS. NOTHING CONTAINED IN THIS WARRANTY SHALL BE CONSTRUED AS OBLIGATING WEBER TO INCORPORATE SUCH DESIGN CHANGES INTO PREVIOUSLY MANUFACTURED PRODUCTS, NOR SHALL SUCH CHANGES BE CONSTRUED AS AN ADMISSION THAT PREVIOUS DESIGNS WERE DEFECTIVE.

Webster-Stephen Products LLC
Customer Service Center
1415 S. Roselle Road
Palatine, IL 60067
U.S.A.

For replacement parts, call:
1-800-446-1071

COOKING SYSTEM

Your WEBER charcoal grill is designed with a smart fan/temperature control feature for the cooking system. This grill can be used with or without this feature depending on your preference. Both cooking methods produce excellent results and give you a choice of how you want to grill.

A Fan control

Using the WEBER LCD Wi-Fi® Enabled Controller and fan adds an additional level of controlled cooking. By closing the bowl vents and setting a target temperature you can control and monitor the internal temperature of your grill.

Extensive thought was put into how your WEBER charcoal grill was designed. We design our grills to perform so that you never have to worry about flare-ups, hot and cold spots, or burnt food. Expect excellent performance, control, and results every time.

B Dampers and Vents

A big factor in charcoal grilling is air. The more air that you allow into the grill, the hotter the internal temperature will be until the fuel has been maximized. During cooking, you can control the internal grill temperature by easily adjusting the lid damper and bowl vents. To ensure a high internal grill temperature for direct method cooking, be sure that the bowl and lid vents are fully open. If your intention is to cook indirectly at lower temperatures, you can close the lid and bowl dampers as much as halfway. Closing the dampers completely will cut off oxygen flow and will eventually extinguish the coals.

C ONE-TOUCH Cleaning System

The ONE-TOUCH cleaning system makes cleanup hassle free. As you move the handle back and forth, the three blades in the bowl move ash from the bottom of the grill into the ash catcher. These same vents help bring oxygen up to the fire or to allow you to easily extinguish the fire.

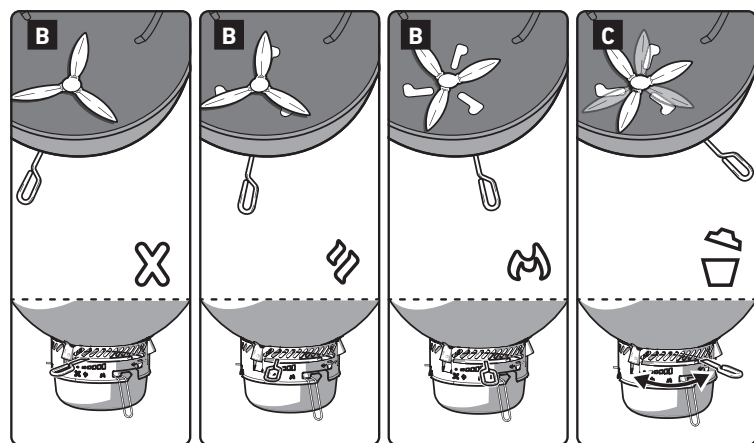
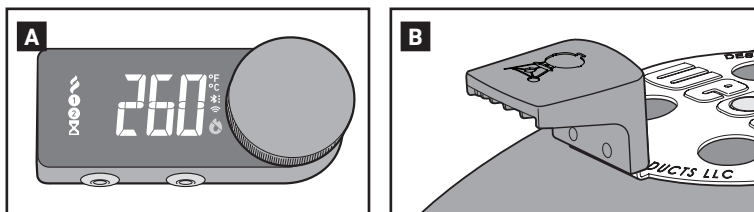

SPECIAL FEATURES

Depending on the model you purchased, your grill may or may not be equipped with the features described on this page.

D WEBER LCD Wi-Fi® Enabled Controller

The WEBER LCD Wi-Fi® Enabled Controller helps you monitor and maintain a consistent temperature while grilling. The controller display can be used to see the grill's ambient temperature, timer, food probe functions, and send alerts and notifications.

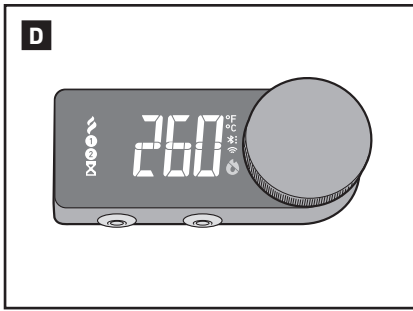

E Food Probe

The included food probe/s allows for accurate temperature reading and alerts on your controller and wireless device.

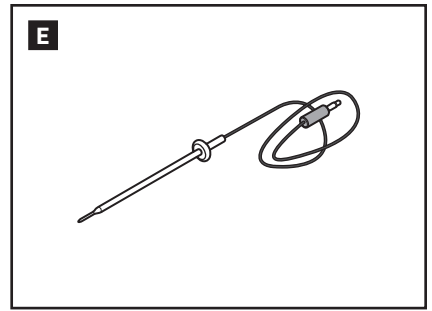

F TUCK-AWAY Lid Holder

The TUCK-AWAY lid holder allows you to easily move your lid to the side to check your meal or to add charcoal.

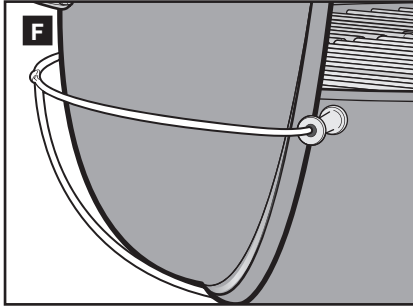

G Hinged Cooking Grate

The hinged cooking grate has an area on both sides that lift up to allow you to easily add fuel.

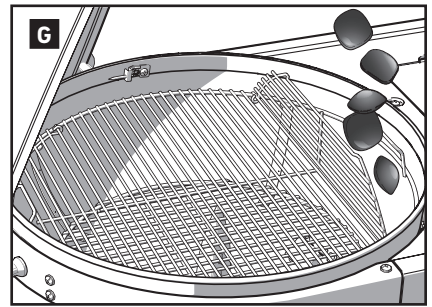

H High Capacity Ash Catcher

The fully enclosed high capacity ash catcher keeps ashes from blowing around and easily detaches for quick and clean ash removal.

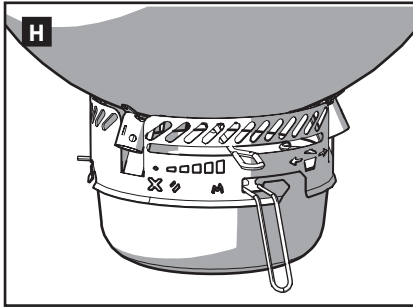

I Curved Cooking Grate Handles

The curved handles of the cooking grate allow you to hang the grate from the side panel of the grill.

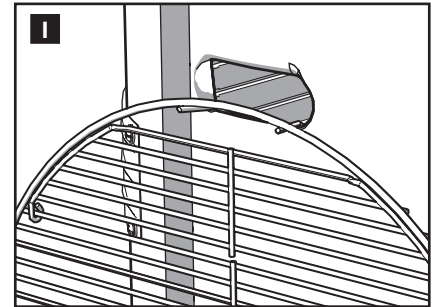

J Table Top

The table top provides a convenient work surface and food prep area.

K WEBER WORKS Table

This table top provides a removable insert to use with WEBER WORKS accessory storage.

This feature is included on select models only.

L Storage Shelving

Built-in storage shelving helps keep accessories and grilling tools within reach.

Storage shelving is included on select models only.

M Charcoal Rails

Arranges charcoal for indirect cooking.

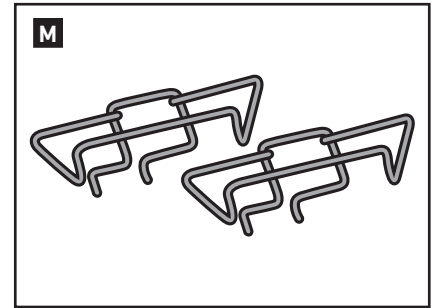
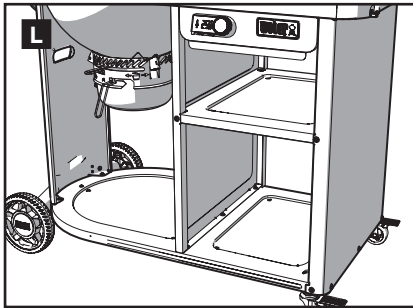
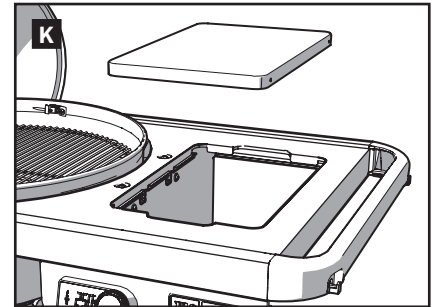
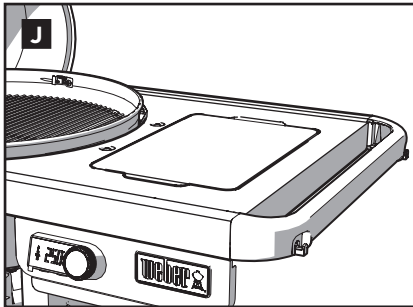

USE AND SETUP USING THE WEBER LCD Wi-Fi® ENABLED CONTROLLER

GETTING STARTED

WEBER CONNECT App



First things first.

Download the WEBER CONNECT app.

Open the app to receive:

- Precise temperature set-up
- Cooking modes, including: Roasting, smoking, and searing..
- Remote grill monitoring
- STEP-BY-STEP BARBECUING
- App-enabled food thermometers
- Recipes and instructions
- And more!

Connecting your grill to Bluetooth® or a Wi-Fi® network.

To connect your WEBER grill via Bluetooth® or your local Wi-Fi® network, follow these steps:

NOTE: WEBER recommends that your smart device runs the latest version of its operating system before attempting to connect your grill to Bluetooth® or your Wi-Fi® router.

- 1) Turn the dial on the temperature controller to turn the display ON.
- 2) Verify that your smart device is connected to Bluetooth® or your local Wi-Fi® network.
- 3) From your smart device, download the new WEBER CONNECT app from the App Store on Apple devices, or the Play Store on Android devices.
- 4) Open the WEBER CONNECT app and follow the in-app instructions for connecting to your WEBER grill.
- 5) Ensure that the temperature controller is plugged into a power source. The power cord must be plugged into the controller module under the table top and a properly grounded outlet.

NOTE: To successfully connect your smart device to your grill via a local Wi-Fi® network, first make sure your grill is paired via Bluetooth® and that your grill is within range of your Wi-Fi® router. If your attempts to connect have been unsuccessful, try moving the grill within range of the Wi-Fi® router or adding a signal extender for a stronger signal.

Scan the QR code to download the WEBER CONNECT app.



WEBER LCD Wi-Fi® ENABLED CONTROLLER

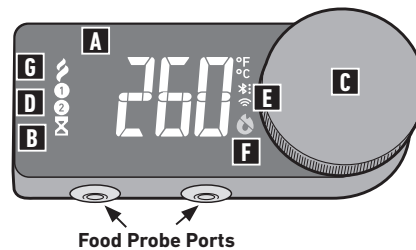

A Dashboard

The LCD display dashboard on your controller is where you can visually check temperatures, receive notifications, view connectivity status, and check the status of your cook.

Note: Fahrenheit and Celsius is set through the WEBER CONNECT App.

B Timer

A timer icon  indicates the timer function.

C Main Dial

Turn the Main Dial to adjust grill temperature, navigate through the icons, and set a timer.

D Food Probe Icons

Your grill has two food temperature probe ports to gain superior control over your grill for perfect results every time.

E Connectivity Icons

These icons indicate strength of your grill's Bluetooth®  and Wi-Fi®  connection.

F Fire Icon

This icon indicates when the grill is in an active cook mode. It will have a strike through when shutting down.

G Manual Mode

Navigate to this icon to activate the manual fan function.

GRILL SETUP USING THE WEBER LCD Wi-Fi® ENABLED CONTROLLER

IMPORTANT:



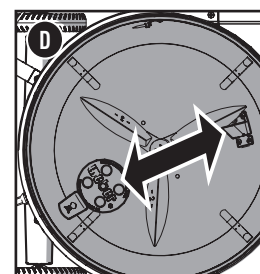
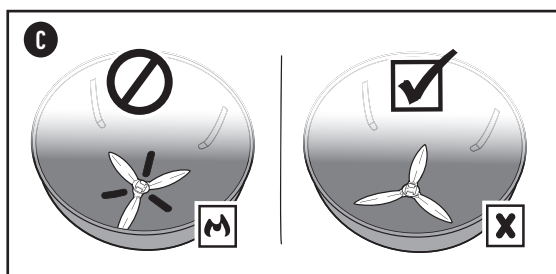
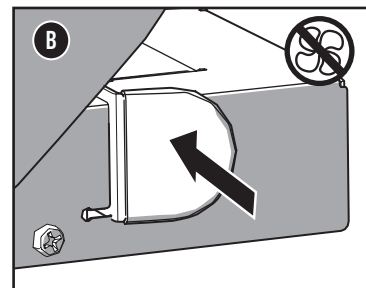
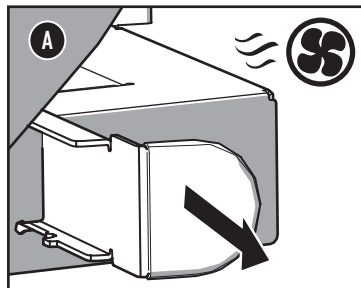

Charcoal requires oxygen to burn, so be sure the fan door is in the proper position when igniting and shutting off the grill.

- To allow oxygen to flow into the kettle when igniting the grill, pull the fan door toward you to open it (A). Use heat-resistant barbecue mitts or gloves while adjusting fan door.
- To prevent oxygen flow into the kettle when shutting off the grill, push the fan door in to close it (B). Use heat-resistant barbecue mitts or gloves while adjusting fan door.

1. Remove the lid and cooking grate (top grate) from your grill.
 2. **IMPORTANT:** Fully close the (bottom) bowl vents on your grill (C).
 3. Choose and follow your preferred cooking method from "RECOMMENDED CHARCOAL SET-UPS WHEN USING THE WEBER LCD WI-FI® ENABLED CONTROLLER". Then, proceed to "SETTING TARGET TEMPERATURE".
 4. Be sure to position lid with lid damper on the opposite side of the fan tunnel (D).
 5. Make final adjustments to LID DAMPER while cooking. Do not fully close.
- Use heat-resistant barbecue mitts or gloves while cooking, adjusting air vents (dampers), adding charcoal, adjusting the fan door, and handling thermometer or lid.

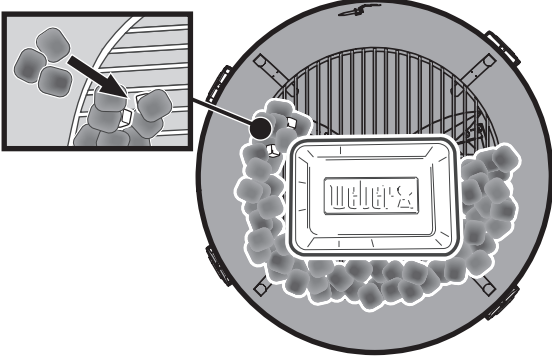

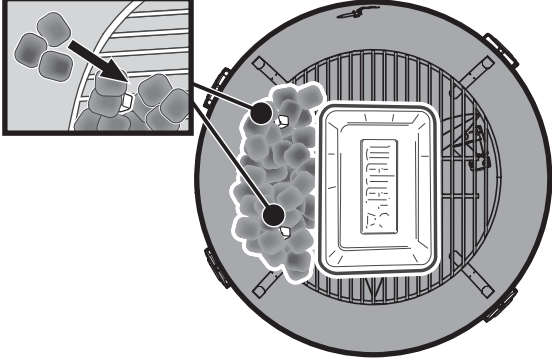
RECOMMENDED CHARCOAL SETUPS WHEN USING THE WEBER LCD Wi-Fi® ENABLED CONTROLLER

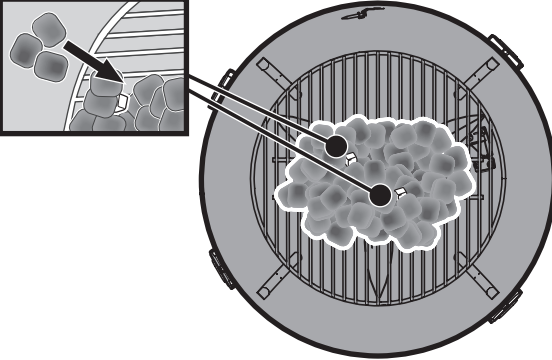
	Fuel Quantity	Temperature	Lid Damper	Charcoal Setup	Instructions
Low and Slow	4 - 5 lbs - thin row of briquettes (75-95 briquettes)	180°-220°F	1/4 open 		<p>Low and Slow Temperature Cooking (180° - 295°F)</p> <p>The charcoal will be arranged in a ring around the outside perimeter of the bowl. This setup creates a low and slow heat cooking method. <i>Note: The amount of charcoal and thickness of the briquette row will help set the temperature of the cooking area during a long cook.</i></p> <ol style="list-style-type: none"> Place a large drip pan in the middle of the charcoal grate. Add a row of briquettes around the drip pan starting 4-5" away from the thermocouple and ending before the fan tunnel outlet. Place 2 lighter cubes directly on the charcoal grate at the starting point of your charcoal at the back left of the bowl, making sure that they are not directly next to one another. Ignite the lighter cubes. Using long handled tongs, place the 3-4 reserved briquettes on top of lit lighter cubes. Turn the controller dial to set a target grill temperature. Press the dial to confirm. Using heat-resistant barbecue mitts or gloves, pull fan door handle toward you to open position (A) to start air flow. Using heat-resistant barbecue mitts or gloves, install the cooking grate into the bowl. Place the lid on the bowl. Adjust the top lid damper to the 1/4 open position. <p><i>See weber.com for more information.</i></p>
	5+ lbs - thicker row of briquettes (95+ briquettes)	225° - 295°F			
Roasting / Indirect Heat	4 lbs (75 briquettes)	300°F - 420°F	1/2 open 		<p>Roasting / Indirect Heat Temperature Cooking (300° - 445°F)</p> <p>The charcoal will be arranged on the back corner of bowl opposite the fan tunnel outlet. This setup creates an indirect heat cooking area. An optional large drip pan can be used on the opposite side of the bowl to catch food drippings.</p> <ol style="list-style-type: none"> Add the appropriate quantity of charcoal to the left side of the bowl on the charcoal grate. Keep the briquettes at least 4-5" away from the fan tunnel outlet and thermocouple. The included Char-Rails can be used to hold the briquettes in place. Place 2 lighter cubes directly on the charcoal grate on opposite ends of your charcoal pile. Ignite the lighter cubes. Using long handled tongs, place the 3-4 reserved briquettes on top of lit lighter cubes. Turn the controller dial to set a target grill temperature. Press the dial to confirm. Using heat-resistant barbecue mitts or gloves, pull the fan door handle toward you to open position (A) to start air flow. Using heat-resistant barbecue mitts or gloves, install the cooking grate into the bowl. Place the lid on the bowl. Adjust the top lid damper to the 1/2 open position. <p><i>See weber.com for more information.</i></p>
	~6 lbs (~100 briquettes)	425°F to 445°F			
Searing / Direct Heat	~6 lbs (~100 briquettes)	450°F+	Fully open 		<p>Searing / Direct Heat Temperature Cooking (450°F+)</p> <p>The charcoal will be arranged in the center of the bowl. This set up creates a direct heat cooking area.</p> <ol style="list-style-type: none"> Add the appropriate quantity of charcoal to the center of the bowl on the charcoal grate. Keep the briquettes at least 4-5" away from the fan tunnel outlet and thermocouple. Place 2 lighter cubes directly on the charcoal grate making sure that they are not directly next to one another. Ignite the lighter cubes. Using long handled tongs, place the 3-4 reserved briquettes on top of lit lighter cubes. Turn the controller dial to set a target grill temperature. Press the dial to confirm. Using heat-resistant barbecue mitts or gloves, pull the fan door handle toward you to open position (A) to start air flow. Using heat-resistant barbecue mitts or gloves, install the cooking grate into the bowl. Place the lid on the bowl. Adjust the top lid damper to the fully open position. <p><i>See weber.com for more information.</i></p>

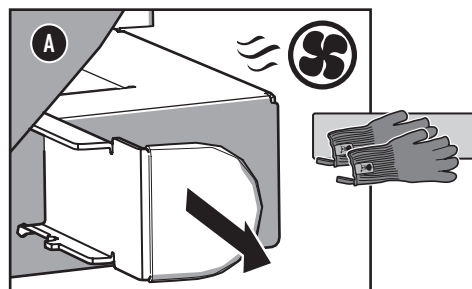

SETTING TARGET TEMPERATURE

Start-Up with WEBER LCD Wi-Fi® Enabled Controller

Refer back to grill and fuel set-ups when using the controller to assist with charcoal ignition.

1. Ensure that the grill is properly plugged in to a power source. The controller display will show three dashes (A). If your grill has been plugged in and the display is not lit, wake your grill by turning the dial.
2. Choose your preferred method of charcoal setup and ignition from the previous section of this manual and setup the grill accordingly.
3. **Rotate** the dial to select a target grill temperature (B).
4. **Press** the dial to confirm the selection. The red flame icon will illuminate and flash as the grill heats (C).
5. Place the lid on the bowl.
6. Adjust the top lid damper to the appropriate position according to your cook setup.
7. Keep the grill lid closed and preheat the grill to the desired cooking temperature.
8. Once the grill has reached the desired temperature, open the lid and clean the cooking grate using a grill brush or scraper.
9. Place the food on the cooking grate, then close the grill lid. Refer to your choice of recipe for cooking times.

To turn off the controller and stop cooking:

1. **Press** and hold the dial for 3 seconds until the controller reads "STOP" on the display (D) - or select **OFF** from your WEBER CONNECT app. **Press** the dial once more to confirm "STOP".
2. **IMPORTANT!** Using heat-resistant barbecue mitts or gloves, **PUSH THE FAN DOOR TO THE CLOSED/OFF POSITION (E)**.
3. Using heat-resistant barbecue mitts or gloves, rotate the lid damper vent closed. The lid damper and fan door must be closed to properly shut down the grill.
4. Unplug the grill from the power source. **DO NOT UNPLUG** until the grill is cool. **WARNING: ALWAYS MAKE SURE THE GRILL IS COMPLETELY COOLED AND UNPLUGGED FROM A POWER SOURCE BEFORE PERFORMING ANY MAINTENANCE OR CLEANING.**

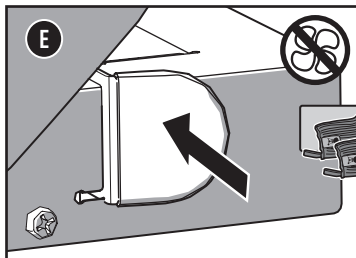
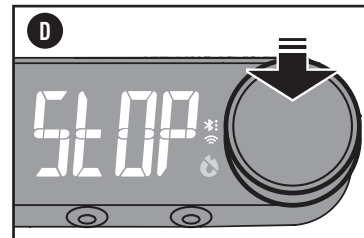
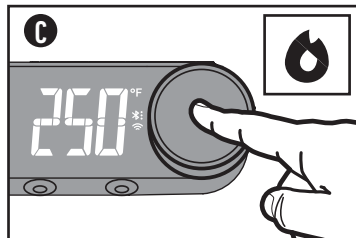
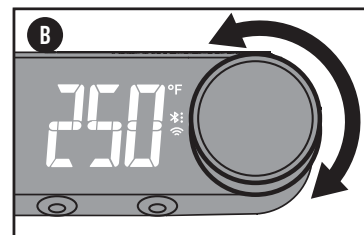
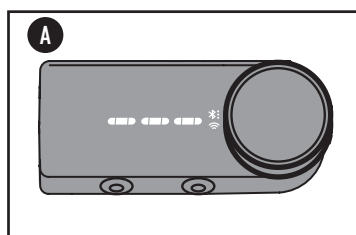

ADDITIONAL FUNCTIONS

TO SET A COOK TIMER

1. **Press** the dial.
2. From the main menu screen, **Rotate** the dial anticlockwise until the hourglass icon illuminates on the display (A).
3. **Press** the dial once for timer adjustment mode (B).
4. **Rotate** the dial to select a time. The default time starts at 5 minutes (C).
5. **Press** the dial to confirm the selection and start the timer.

Note: Cancel your set cook timer with the WEBER CONNECT app.

MANUAL MODE:

Manual mode is a setting that allows continual operation of the fan speed manually.

1. From the Main Menu, **Rotate** the dial all the way left or right until "FAN" is displayed on the controller.
2. **Press** the dial and **Rotate** it to select the fan speed. Fan speed settings: From 1 to 10 (Highest setting).
3. **Press** the dial to confirm the selection.

USING FOOD PROBES:

To set a target food probe temperature:

- 1) Plug in a food probe to the bottom of the controller. The controller can hold up to two food probes at once.
- 2) To set a target food probe temperature from the main menu screen, **Rotate** the dial anticlockwise until the (1) or (2) food probe indicator illuminates on the display (D).
- 3) **Press** the dial once for probe temperature adjustment mode.
- 4) **Rotate** the dial to select a target food probe temperature. The default temperature starts at 165°F (74°C).
- 5) **Press** the dial to confirm the selection.
- 6) Alternatively, from the WEBER CONNECT app, select a desired food to cook or select a cook program. You will receive a notification once your food has reached the set temperature(s) and your cook has ended.

IMPORTANT OPERATING NOTES

- **Do not overload charcoal. Using more than the recommended amount of fuel can cause damage to electronics**
- **High Temperature Protection feature:** Do not unplug power to the grill until the grill has completely cooled. The electronics housing has an onboard temperature sensor. If too much heat is detected, the fan will spin at a low speed to cool the housing even if a cook is active.
- When setting up your grill for direct searing or roasting you should follow the recommended charcoal set-up on the previous page for safe cooking temperatures.
- Due to the fan rotating air around the kettle, it is not necessary to reposition your cooking grate mid-cook for an even, indirect cook.

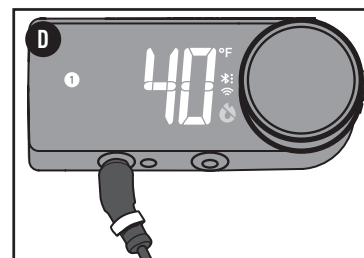
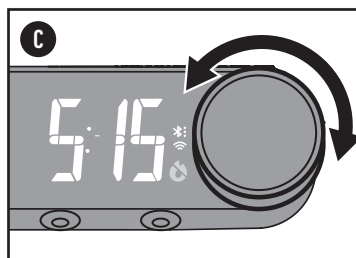
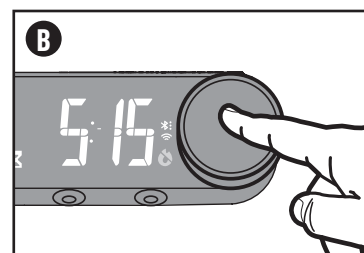
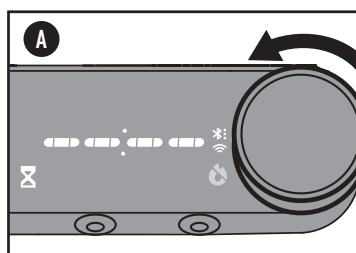

- E2 - Fan Error
 - E3 - Flame Out
 - E4 - Communication Error
 - E5 - Grill Too Hot
 - E8 - Thermocouple Error
 - E10 - Improper Shutdown Notification
 - E13 - Diagnostic Component Failure
 - E16 - Grill ID Error
- Some error codes simply notify you of a potential critical error before it happens. These notifications can be cleared from the controller by pressing the dial.
- E18 - Temperature Drop Notification
 - E34 - Fan Door Error
 - E36 - Internal Software Update Error
 - E37 - Probe is Overheating

USE AND SETUP WITHOUT USING THE WEBER LCD Wi-Fi® ENABLED CONTROLLER

Your WEBER charcoal grill can be used without the WEBER LCD Wi-Fi® Enabled Controller. Simply use the preferred charcoal ignition method using charcoal lighter cubes. Control the amount of oxygen by adjusting the bottom bowl vents and the lid damper. Follow the steps below for grill setup and ignition for direct and indirect grilling.

BEFORE LIGHTING

Choose a Proper Location to Grill

- Only use this grill outdoors in a well-ventilated area. Do not use in a garage, building, breezeway, or any other enclosed area.
- Keep the grill on a secure, level surface at all times.
- Do not use the grill within two feet (60cm) of any combustible material. Combustible materials include, but are not limited to, wood or treated wood decks, patios, and porches.

Choose How Much Charcoal to Use

Choosing charcoal quantity depends on what you are grilling and the size of your grill. If you are grilling small, tender pieces of food that take less than 20 minutes, refer to the **Charcoal Quantity for Direct Heat** chart. If you are intending to grill larger joints of meat that require 20 minutes or more of grilling time, or delicate foods, refer to the **Charcoal Quantity for Indirect Heat** chart. For more details about the difference between direct and indirect cooking, refer to the **GRILLING METHODS** sections.

The Very First Time You Grill

It is recommended that the grill be heated up and the fuel kept red hot, with the lid on, for at least 30 minutes prior to cooking for the first time to burn off any manufacturing residue.

Preparing the Grill for Lighting

1. Slide the lid open into the TUCK-AWAY lid holder.
2. Remove the cooking grate from the grill.
3. Remove the charcoal (bottom) grate and clear ashes or chunks of old charcoal from the bottom of the bowl using the ONE-TOUCH cleaning system. Charcoal requires oxygen to burn, so be sure that nothing clogs the vents. Move the handle back and forth to move ash and debris from the bottom of the grill into the ash catcher (A).
4. To remove the high capacity ash catcher and dispose of the ashes, lift and rotate the ash catcher handle to the right to release it from the grill (B).
5. Open the bowl vents by moving the ONE-TOUCH damper blade handle to the fully open position (C).
6. Reinstall the charcoal (bottom) grate.

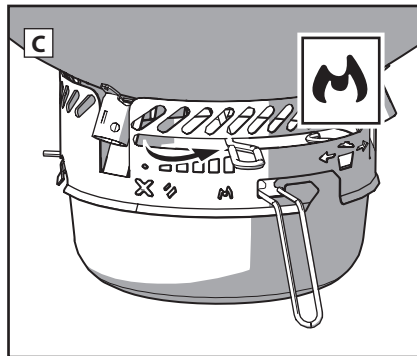
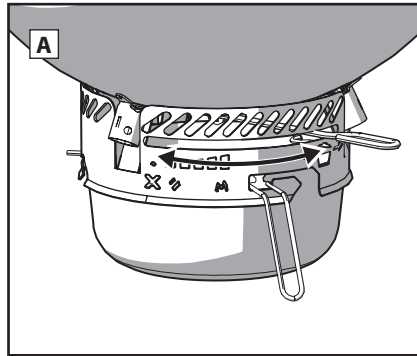

7. Open the lid vents by moving the lid damper to the fully open position (D).

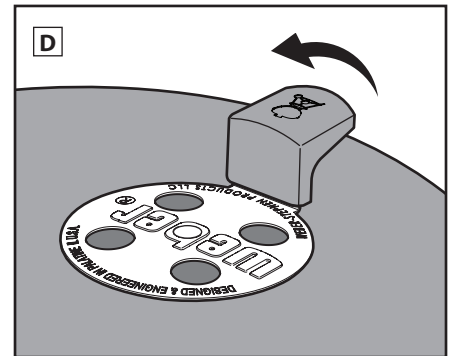
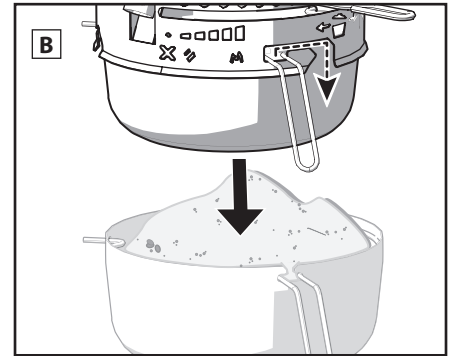

Note: Instructions for using lighter fluid were purposely left out of this owner's guide. Lighter fluid is messy and can transmit a chemical taste to your food, while lighter cubes (sold separately) do not. If you choose to use lighter fluid, follow the manufacturer's instructions and NEVER add lighter fluid to a burning fire.

LIGHTING CHARCOAL

Before lighting charcoal, determine which barbecuing method you will be using. Depending on the model you purchased, your grill may or may not be equipped with the features described on the following pages.

Setting Up the Grill for Direct Grilling Method

Lighting the Charcoal Using a Chimney Starter

The simplest, most thorough way to light any kind of charcoal is to use a chimney starter; particularly, the WEBER RAPIDFIRE chimney starter (sold separately). Refer to the cautions and warnings included with the RAPIDFIRE chimney starter before lighting charcoal.

1. Put a few sheets of crumpled up newspaper in the bottom of the chimney starter and set the chimney starter on the charcoal (bottom) grate (A); or put a few lighter cubes (sold separately) in the center of the charcoal grate and place the chimney starter over them (B).
2. Fill the chimney starter with charcoal (C).
3. Using a long lighter or matchstick, light the lighter cubes or newspaper through the holes on the bottom side of the chimney starter (D).
4. Keep the chimney starter in place until the charcoal is fully lit. You know the charcoal is fully lit when it is covered with a coating of white ash.

Note: Lighter cubes must be completely consumed and the charcoal ashed over before placing food on the cooking grate. Do not cook before the charcoal has a coating of ash.

5. Once the charcoal is fully lit, continue to the following pages for instructions on how to arrange your charcoal and begin cooking according to your desired grilling method.

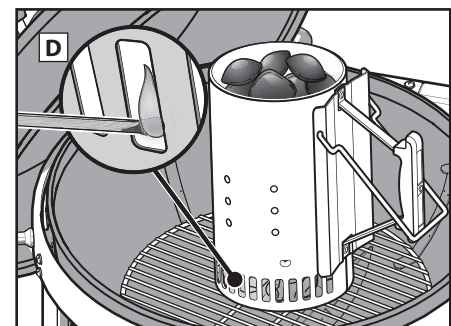
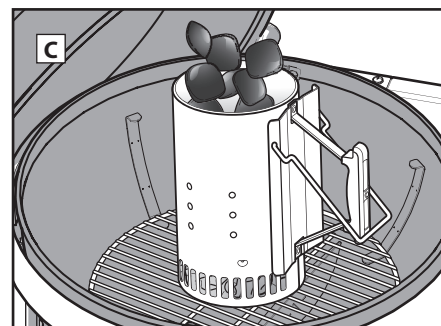
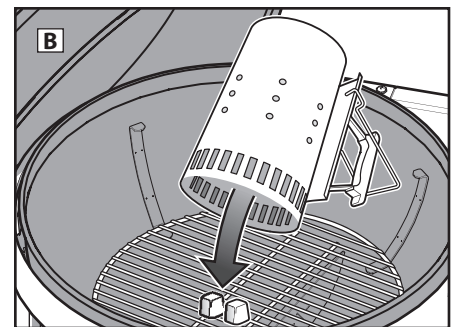
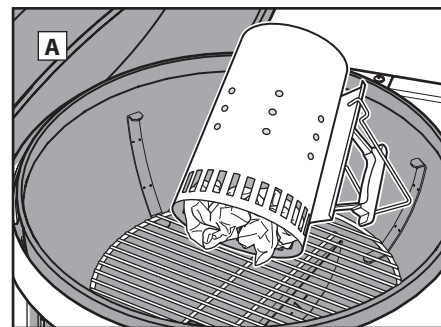

Charcoal Quantity for Direct Heat

Hamburgers, steaks, chops, kabobs, boneless chicken pieces, fish fillets, shellfish, sliced vegetables

Grill Diameter	WEBER Briquettes Needed	Charcoal Briquettes Needed
22" (57 cm)	40	50

Charcoal Quantity for Indirect Heat

Roasts, bone-in poultry pieces, whole fish, delicate fish fillets, whole chickens or turkeys, ribs

Grill Diameter	WEBER Briquettes Needed for First Hour	WEBER Briquettes Added for Each Additional Hour	Charcoal Briquettes Needed for First Hour	Charcoal Briquettes Added for Each Additional Hour
22" (57 cm)	15 per side	7 per side	25 per side	8 per side

LIGHTING CHARCOAL

Lighting the Charcoal Without a Chimney Starter

1. Build a pyramid of charcoal in the center of the charcoal (bottom) grate and insert a couple of lighter cubes (sold separately) within the pyramid.
2. Using a long lighter or matchstick, light the lighter cubes. The lighter cubes will then ignite the charcoal (E).
3. Wait for the charcoal to fully light. You know the charcoal is fully lit when it is covered with a coating of white ash.

Note: Lighter cubes must be completely consumed and the charcoal ashed over before placing food on the cooking grate. Do not cook before the charcoal has a coating of ash.

4. Once the charcoal is fully lit, continue to the following pages for instructions on how to arrange your charcoal and begin cooking according to your desired grilling method.

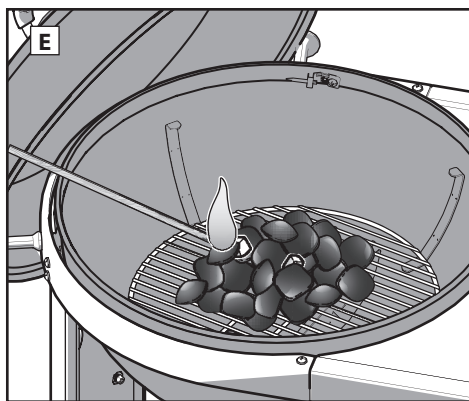

Setting Up the Grill for Indirect Grilling Method

When using the indirect grilling method, you have the option to spread the coals directly on the charcoal (bottom) grate on opposite sides of the bowl, or make use of WEBER CHAR-RAILS or CHAR-BASKETS (sold separately).

△ Avoid positioning charcoal directly beneath the thermometer and lid damper.

△ When using the CHAR-RAILS or CHAR-BASKETS, they must first be placed into the bowl of the grill on the charcoal (bottom) grate before lighting the charcoal.

To install the CHAR-RAILS, hook them on the outer charcoal grate wires (A), and push the front of the rails down. The front of the CHAR-RAILS should slip over the fourth charcoal grate wire and snap into place (B).

Lighting the Charcoal Using a Chimney Starter

The simplest, most thorough way to light any kind of charcoal is to use a chimney starter; particularly, the WEBER RAPIDFIRE chimney starter (sold separately). Refer to the cautions and warnings included with the RAPIDFIRE chimney starter before lighting charcoal.

1. Put a few sheets of crumpled up newspaper in the bottom of the chimney starter and set the chimney starter on the charcoal (bottom) grate between the CHAR-RAILS or CHAR-BASKETS if they are being used. Alternatively, you can put a few lighter cubes (sold separately) in the center of the charcoal (bottom) grate. Place the chimney starter over the lighter cubes and fill the chimney starter with charcoal (C).
2. Using a long lighter or matchstick, light the lighter cubes or newspaper through the holes on the bottom side of the chimney starter (D).

3. Keep the chimney starter in place until the charcoal is fully lit. You know the charcoal is fully lit when it is covered with a coating of white ash.

Note: Lighter cubes must be completely consumed and the charcoal ashed over before placing food on the cooking grate. Do not cook before the charcoal has a coating of ash.

4. Once the charcoal is fully lit, continue to the following pages for instructions on how to arrange your charcoal and begin cooking according to your desired grilling method.

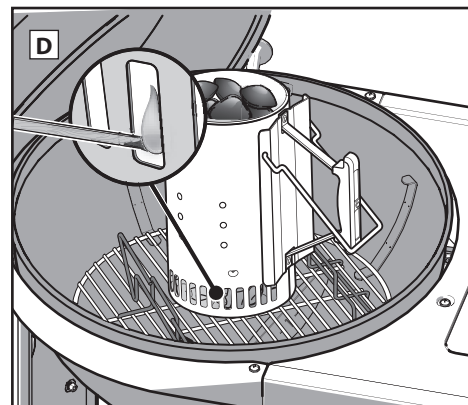
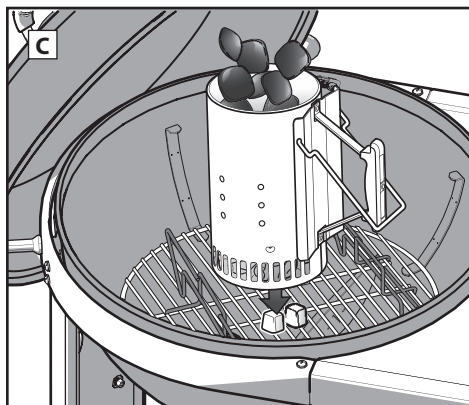
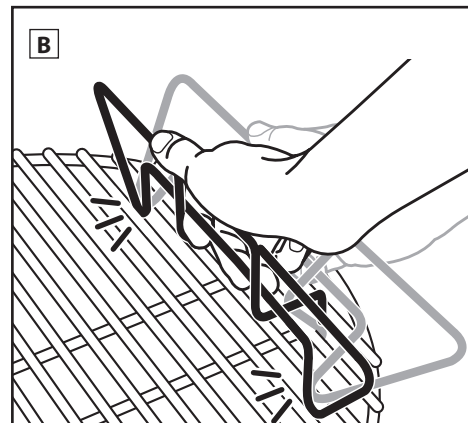
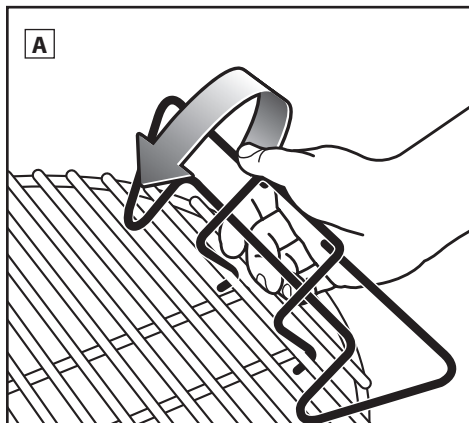

Lighting the Charcoal Without a Chimney Starter

△ Avoid positioning charcoal directly beneath the thermometer and lid damper.

△ When using the CHAR-RAILS or CHAR-BASKETS, they must first be placed into the bowl of the grill on the charcoal (bottom) grate before lighting the charcoal.

1. Place CHAR-RAILS or CHAR-BASKETS on the charcoal (bottom) grate on opposite sides of the bowl.
2. Fill each CHAR-RAIL or CHAR-BASKET with your choice of charcoal. Avoid positioning charcoal directly beneath the thermometer and lid damper (E). A drip pan may be placed between the charcoal to collect food drippings.

3. Insert a couple of lighter cubes (sold separately) within the charcoal.

Note: Be sure to slightly bury them at the top of the charcoal briquettes.

4. Using a long lighter or matchstick, light the lighter cubes (F). The lighter cubes will then ignite the charcoal.

5. Wait for the charcoal to fully light. You know the charcoal is fully lit when it is covered with a coating of white ash.

Note: Lighter cubes must be completely consumed and the charcoal ashed over before placing food on the cooking grate. Do not cook before the charcoal has a coating of ash.

6. Once the charcoal is fully lit, continue to the following pages for instructions on how to arrange your charcoal and begin cooking according to your desired grilling method.

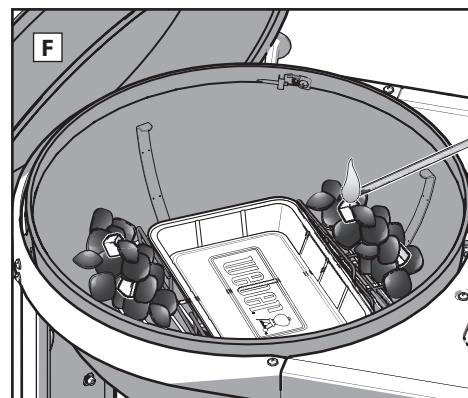
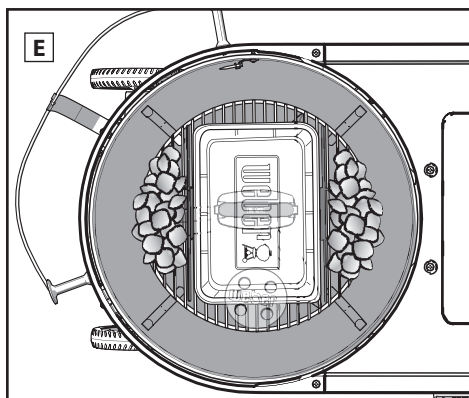

GRILLING METHODS - DIRECT HEAT

Arranging the Charcoal for Direct Heat

1. Put on barbecue mitts or gloves.

CAUTION: The grill, including the handle and damper/vent handles, will become hot. Make sure that you are wearing barbecue mitts or gloves to avoid burning your hands.

2. After the charcoal is fully lit, spread them evenly across the charcoal grate with long handle tongs (A) or using a WEBER charcoal rake (sold separately).
3. Make sure the ONE-TOUCH cleaning system handle and lid damper are in the fully open position (B), (C).
4. Once the charcoal has ashed over, reinstall the cooking grate inside the bowl.
5. Slide the lid closed on the grill.
6. Preheat the cooking grate for approximately 10 to 15 minutes.
7. Once the cooking grate is preheated, slide the lid open. Using a grill brush or scraper, scrub the cooking grate clean.

Note: When using a stainless steel bristle grill brush, replace the brush if any loose bristles are found on the cooking grate or brush.

8. Place your food on the cooking grate.

Note: When removing the grill lid during cooking, slide it to the side, rather than straight up. Lifting straight up may create suction, drawing ashes up onto your food.

9. Slide the lid closed and consult recipe for recommended cooking times.

When finished cooking...

Close the lid damper and bowl vents to extinguish the charcoal (D).

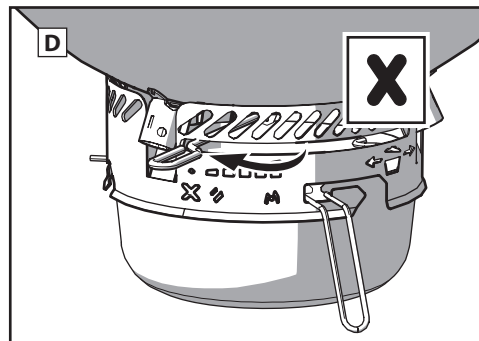
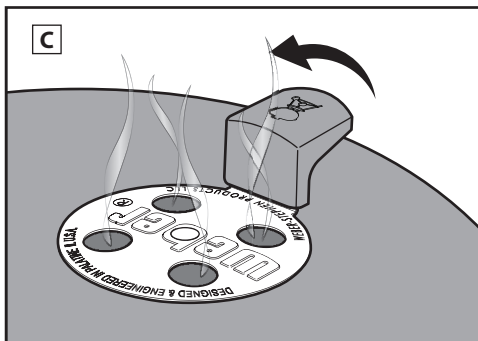
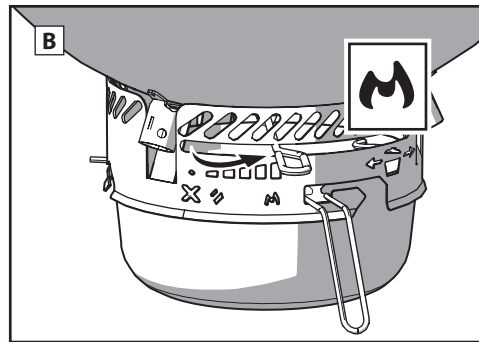
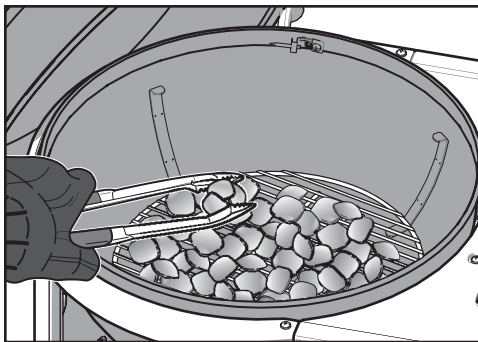

GRILLING METHODS - INDIRECT HEAT

Arranging the Charcoal for Indirect Heat

1. Put on barbecue mitts or gloves.

CAUTION: The grill, including the handles, lid damper and bowl vents, will become hot. Make sure that you are wearing barbecue mitts or gloves to avoid burning your hands.

2. Once the charcoal is fully lit using your preferred indirect grilling method (refer to "Lighting Charcoal" section), using barbecue mitts or gloves and long handle tongs, be sure that the charcoal is properly positioned on opposite sides of the bowl. Avoid positioning the charcoal next to the bowl handles, or directly beneath the thermometer and lid damper (A). A drip pan may be placed between the charcoal to collect food drippings.

3. Make sure the ONE-TOUCH cleaning system handle and lid damper are in the fully open position (B), (C).

4. Once the charcoal has ashed over, reinstall the cooking grate inside the bowl. If your cooking grate has hinged sides, make sure that they are directly above the charcoal inside the bowl. This will make it easy to add more charcoal if needed.

5. Slide the lid closed on the grill.

6. Preheat the grate for approximately 10 to 15 minutes.

7. Once the cooking grate is preheated, slide the lid open. Using a grill brush or scraper, scrub the cooking grate clean.

Note: When using a stainless steel bristle grill brush, replace the brush if any loose bristles are found on the cooking grate or brush.

8. Place your food in the center of the cooking grate, above a drip pan if using one.

Note: When removing the grill lid during cooking, slide it to the side, rather than straight up. Lifting straight up may create suction, drawing ashes up onto your food.

9. Slide the lid closed. Always position the lid so that the thermometer is not above the charcoal where it will be exposed to direct heat. Consult recipe for recommended cooking times. Adjust the lid damper and bowl vent positions to lower the interior grill temperature if needed.

Note: Rotate the lid damper fully open to raise the grill temperature and close it more to lower the grill temperature.

When finished cooking...

Close the lid damper and bowl vents to extinguish the charcoal (D).

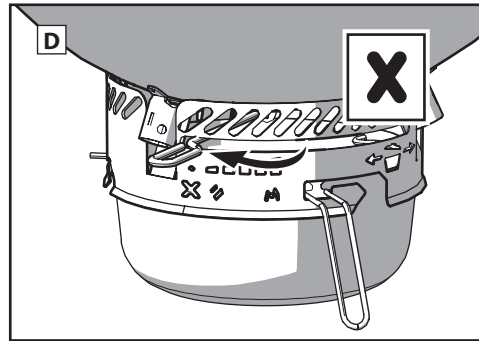
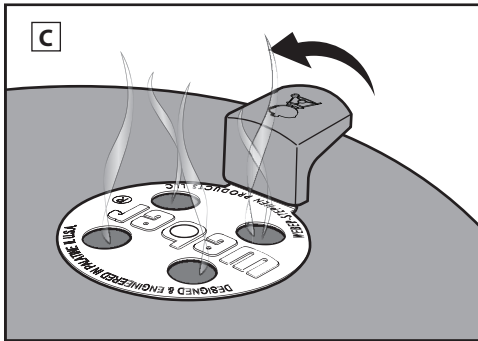
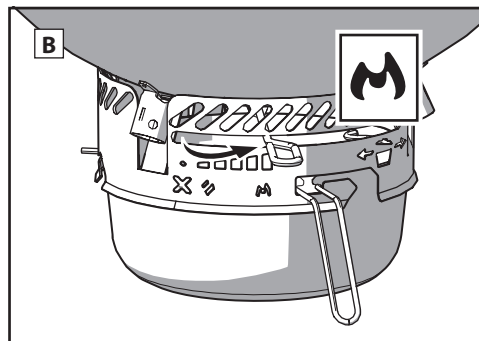
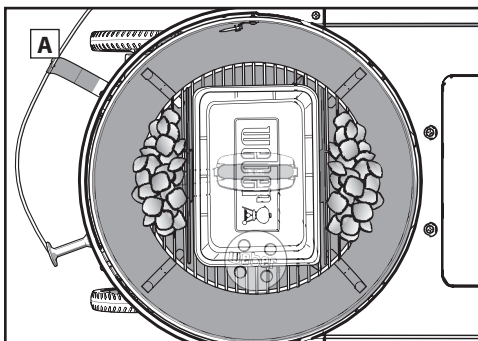

TIPS AND TRICKS

Wear Gloves

Always wear a barbecue mitt or mitts when using your charcoal grill. Vents, dampers, handles, and the bowl will all get hot during the grilling process, so be sure to keep your hands and forearms protected.

Skip the Lighter Fluid

Avoid using lighter fluid, as it can impart a chemical taste to your food. Chimney starters (sold separately) and lighter cubes (sold separately) are much cleaner and much more effective ways of lighting charcoal.

Preheat the Grill

Preheating your grill with the lid closed for 10 to 15 minutes prepares the cooking grate. With all of the charcoal glowing red, the temperature under the lid should reach 500° F. The heat loosens any bits and pieces of food hanging onto the grate, making it easy to brush them off with a stainless steel bristle grill brush. Preheating your grill gets the grate hot enough to sear properly and also helps prevent food from sticking to the grate.

Note: Use a stainless steel bristle grill brush. Replace brush if any loose bristles are found on cooking grate or brush.

Oil the Food, Not the Grate

Oil prevents food from sticking and also adds flavor and moisture. Lightly brushing or spraying the food with oil works better than brushing the grate.

Keep the Air Flowing

A charcoal fire needs air. The lid should be closed as much as possible, but keep the lid damper and bowl vent open. Remove the ashes on the bottom of the grill regularly to prevent them from blocking the vents.

Put a Lid on It

For four important reasons, the lid should be closed as much as possible.

1. Keeps the grate hot enough to sear the food.
2. Speeds up the cooking time and prevents the food from drying out.
3. Traps the smokiness that develops when fat and juices vaporize in the grill.
4. Prevents flare-ups by limiting oxygen.

Tame the Flame

Flare-ups happen, which is good because they sear the surface of what you are grilling; however, too many flare-ups can burn your food. Keep the lid on as much as possible. This limits the amount of oxygen inside the grill, which will help extinguish any flare-ups. If the flames are getting out of control, move the food over indirect heat temporarily, until they die down.

Frozen or Fresh

Whether you are grilling frozen or fresh food, follow the safety guidelines on the package and always cook it to the recommended internal temperature. Frozen food will take longer to grill and may need more fuel to be added depending on the type of food.

Keeping it Clean

Follow a few basic maintenance instructions to keep your grill looking and grilling better for years to come!

- For proper air flow and better grilling, remove accumulated ashes and old charcoal from the bottom of the kettle and the ash catcher before use. Make sure that all of the charcoal is fully extinguished and the grill is cool before doing so.
- You may notice "paint-like" flakes on the inside of the lid. During use, grease and smoke vapors slowly oxidize into carbon and deposit on the inside of your lid. Brush the carbonized grease from the inside of the lid with a stainless steel bristle grill brush. To minimize further build-up, the inside of the lid can be wiped with a paper towel after cooking while the grill is still warm (not hot).
- Clean painted, porcelain-enameled, and plastic surfaces on the outside of your grill with warm soapy water and a non-abrasive cloth.
- If your grill is subject to a particularly harsh environment, you will want to clean the outside more often. Acid rain, chemicals, and salt water can cause surface rusting to appear. WEBER recommends wiping down the outside of your grill with warm soapy water. Follow up with a rinse and thorough drying.
- Do not use any of the following to clean your grill: abrasive stainless steel polishes or paints, cleaners that contain acid, mineral spirits or xylene, oven cleaner, abrasive cleansers (kitchen cleansers), and abrasive cleaning pads.

FOOD SAFETY

Food Safety Tips

- Do not defrost meat, fish, or poultry at room temperature. Defrost in the refrigerator.
- Wash your hands thoroughly with hot, soapy water before starting any meal preparation and after handling fresh meat, fish, and poultry.
- Never place cooked food on the same plate raw food was on.
- Wash all plates and cooking utensils that have come into contact with raw meats or fish with hot, soapy water and rinse.

Visit www.weber.com for recipes and grilling tips.

GRILLING GUIDE

Cooking times for beef and lamb use the USDA's definition of medium doneness, unless otherwise noted. The cuts, thicknesses, weights, and grilling times are meant to be guidelines. Factors such as altitude, wind, and outside temperature can affect cooking times.

Visit www.weber.com for recipes and grilling tips.

	Thickness / Weight	Approximate Total Grilling Time
RED MEAT	¾ in (1.9 cm) thick	4 to 6 minutes direct high heat
	Steak: New York strip, porterhouse, rib-eye, T-bone, and filet mignon (tenderloin)	1 in (2.5 cm) thick 6 to 8 minutes direct high heat
	2 in (5 cm) thick	14 to 18 minutes sear 6 to 8 minutes direct high heat, and grill 8 to 10 minutes indirect high heat
	Flank Steak	1½ lb to 2 lb (680 g to 907 g), ¾ in (1.9 cm) thick 8 to 10 minutes direct medium heat
	Ground Beef Patty	¾ in (1.9 cm) thick 8 to 10 minutes direct medium heat
Tenderloin	3 lb to 4 lb (1.36 kg to 1.81 kg) 45 to 60 minutes 15 minutes direct medium heat, and grill 30 to 45 minutes indirect medium heat	
PORK	Bratwurst: fresh	3 oz (85 g) link 20 to 25 minutes direct low heat
	Chop: boneless or bone in	¾ in (1.9 cm) thick 6 to 8 minutes direct high heat
		1¼ in to 1½ in (3.17 cm to 3.81 cm) thick 10 to 12 minutes sear 6 minutes direct high heat, and grill 4 to 6 minutes indirect high heat
	Ribs: baby back, spareribs	3 lb to 4 lb (1.36 kg to 1.81 kg) 1½ to 2 hours indirect medium heat
	Ribs: country-style, bone in	3 lb to 4 lb (1.36 kg to 1.81 kg) 1½ to 2 hours indirect medium heat
Tenderloin	1 lb (453 g) 30 minutes sear 5 minutes direct high heat, and grill 25 minutes indirect medium heat	
POULTRY	Chicken Breast: boneless, skinless	6 oz to 8 oz (170 g to 226 g) 8 to 12 minutes direct medium heat
	Chicken Thigh: boneless, skinless	4 oz (113 g) 8 to 10 minutes direct medium heat
	Chicken Pieces: bone in, assorted	3 oz to 6 oz (85 g to 170 g) 36 to 40 minutes 6 to 10 minutes direct low heat, 30 minutes indirect medium heat
	Chicken: whole	4 lb (1.81 kg) to 5 lb (2.26 kg) 1 to 1½ hours indirect medium heat
	Cornish Game Hen	1½ lb (680 g) to 2 lb (907 g) 60 to 70 minutes indirect medium heat
	Turkey: whole, unstuffed	10 lb (4.53 kg) to 12 lb (5.44 kg) 2 to 2½ hours indirect medium heat
SEAFOOD	Fish, Fillet, or Steak: halibut, red snapper, salmon, sea bass, swordfish, tuna	¾ in to 1½ in (0.63 cm to 1.27 cm) thick 3 to 5 minutes direct medium heat
		1 in to 1¼ in (2.54 cm to 3.17 cm) thick 10 to 12 minutes direct medium heat
	Fish: whole	1 lb (453 g) 15 to 20 minutes indirect medium heat
		3 lb (1.36 kg) 30 to 45 minutes indirect medium heat
Shrimp	1½ oz (28 g) 2 to 4 minutes direct high heat	
VEGETABLES	Asparagus	½ in (1.27 cm) diameter 6 to 8 minutes direct medium heat
	Corn	in husk 25 to 30 minutes direct medium heat
		husked 10 to 15 minutes direct medium heat
	Mushroom	shiitake or button 8 to 10 minutes direct medium heat
		portobello 10 to 15 minutes direct medium heat
	Onion	halved 35 to 40 minutes indirect medium heat
	Potato	½ in (1.27 cm) slices 8 to 12 minutes direct medium heat
whole 45 to 60 minutes indirect medium heat		
	½ in (1.27 cm) slices 9 to 11 minutes parboil 3 minutes, and grill 6 to 8 minutes direct medium heat	

Make sure food fits on the grill with the lid down, leaving approximately 1 inch (2.54 cm) of clearance between the food and lid.

REPLACEMENT PARTS

Performer Premium SMART - 22.5 (57cm) - US 102525

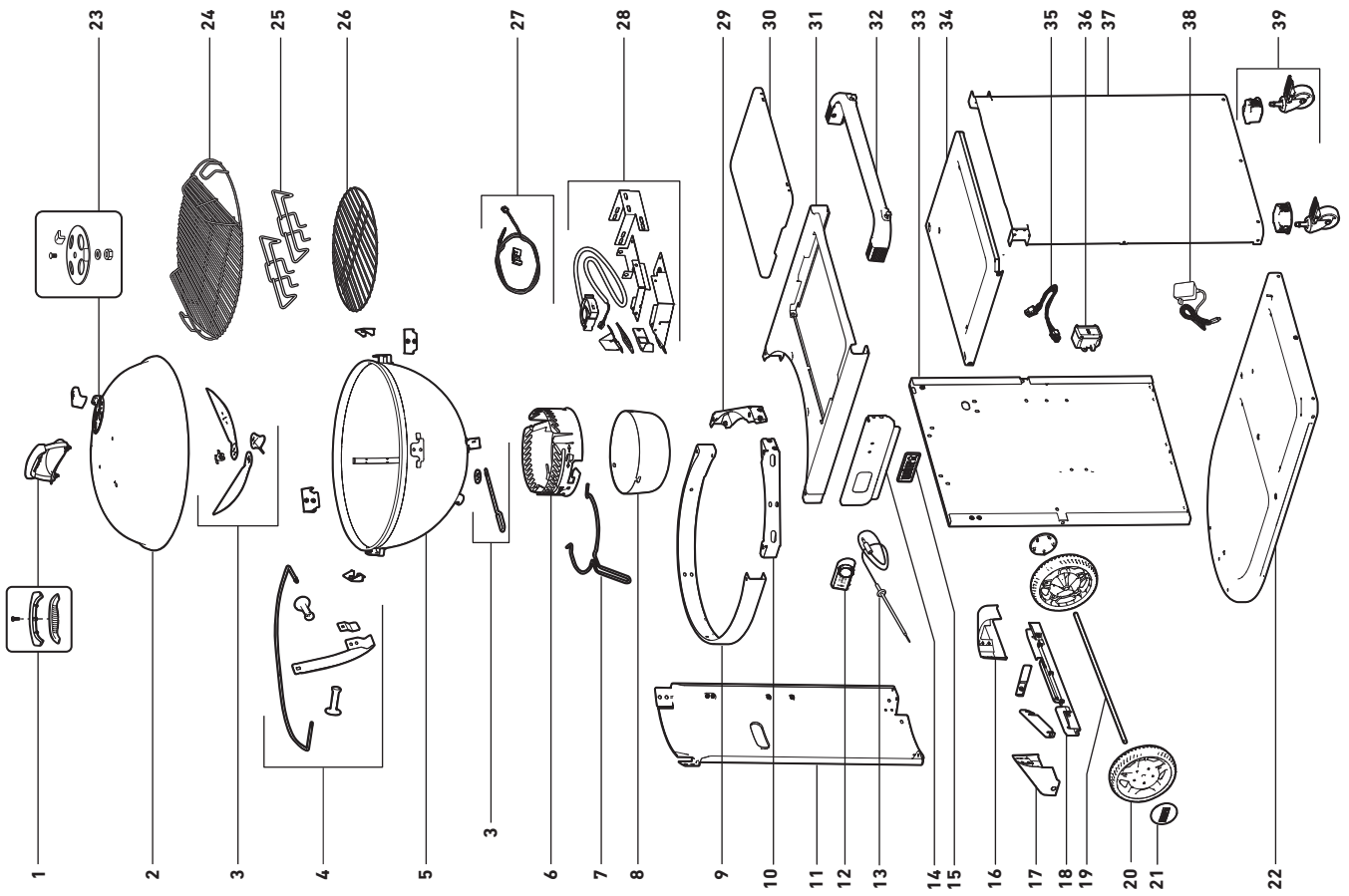

Performer - SMART 22.5 (57cm) - US 102525

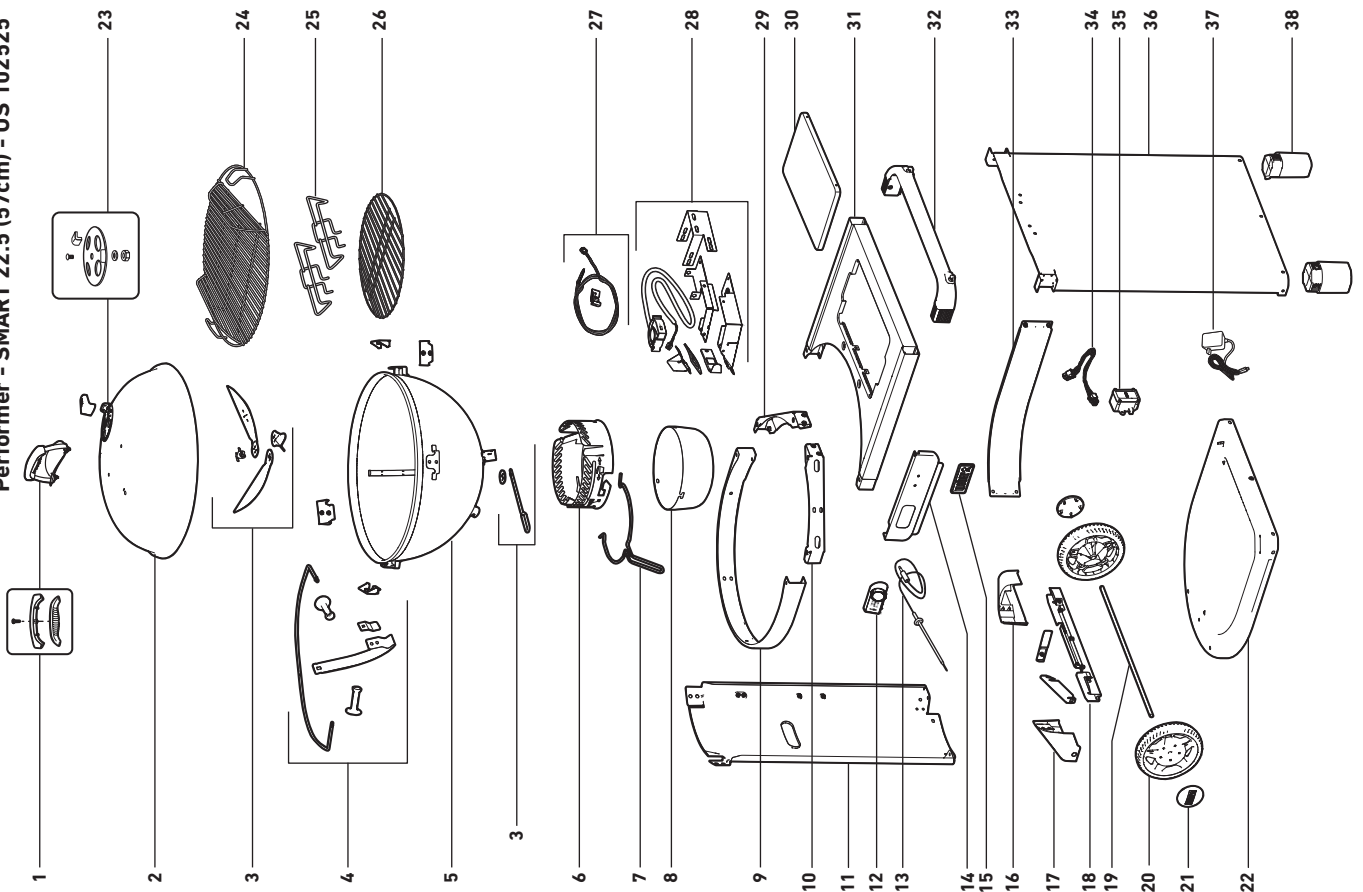

FCC Compliance: This equipment has been tested and found to comply with the limits for a Class B digital device, pursuant to part 15 of the FCC rules. These limits are designed to provide reasonable protection against harmful interference in a residential installation. This equipment generates, uses and can radiate radio frequency energy and, if not installed and used in accordance with the instructions, may cause harmful interference to radio communications. However, there is no guarantee that interference will not occur in a particular installation. If this equipment does cause harmful interference to radio or television reception, which can be determined by turning the equipment off and on, the user is encouraged to try to correct the interference by one or more of the following measures: (1) Reorient or relocate the receiving antenna. (2) Increase the separation between the equipment and receiver. (3) Connect the equipment into an outlet on a circuit different from that to which the receiver is connected. (4) Consult the manufacturer, dealer or an experienced radio/TV technician for help. Changes or modifications not expressly approved by Weber could void the user's authority to operate this device.

FCC Radio Frequency (RF) Exposure: This equipment complies with FCC and ICSED Canada radiation exposure limits set forth for an uncontrolled environment. The user should avoid prolonged exposure within 20cm of the antenna, which may exceed the FCC or RSS-102 radio frequency exposure limits.

IC Compliance: This device contains license-exempt transmitter(s)/receiver(s) that comply with Innovation, Science and Economic Development Canada's license-exempt RSS(s). Operation is subject to the following two conditions: (1) This device may not cause interference; and (2) This device must accept any interference, including interference that may cause undesired operation of the device.

IFETEL Compliance: Operation of this unit is subject to the following two conditions: (1) this unit or device may not cause harmful interference, and (2) this unit or device must accept any interference, including interference that may cause undesired operation.

ULC/ORD-C2728 2019

UL2728A 2019

Model: WCR001



WEBER-STEPHEN PRODUCTS LLC

www.weber.com

© 2025 Designed and engineered by Weber-Stephen Products LLC,
1415 S. Roselle Road, Palatine, Illinois 60067 USA.