

Owner's Manual

CRAFTSMAN®

1 HP (Max. Developed)
2 Speeds
1410 and 2600 F.P.M. (No Load)
Leg Stand

12" BAND SAW

Model No.
137.224320

E82358



37J5 LISTED

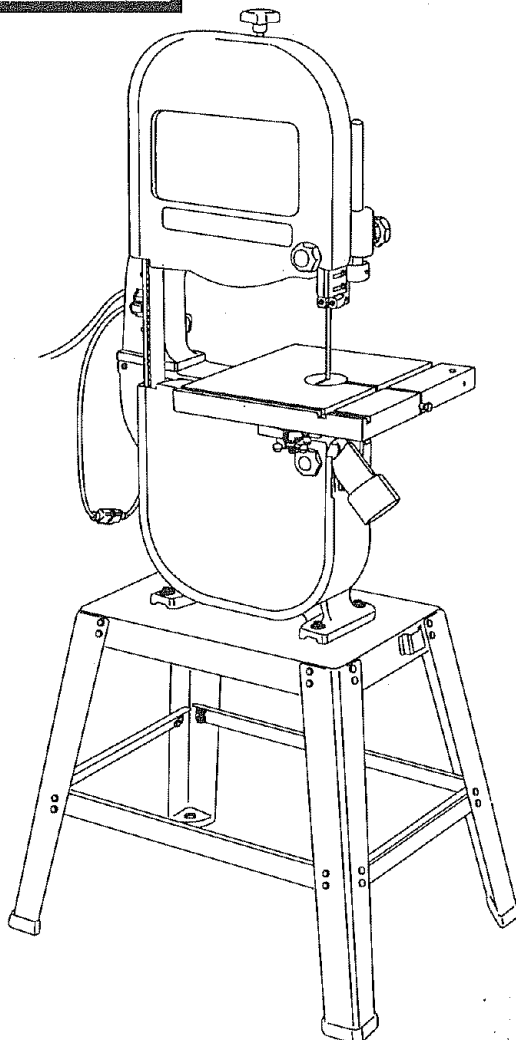

CAUTION:

Before using this band saw, read this manual and follow all its Safety Rules and Operating Instructions.

- Safety Instructions
- Installation
- Operation
- Maintenance
- Parts List

Customer Help Line
1-800-843-1682

Sears, Roebuck and Co., Hoffman Estates, IL 60179 USA
Part No. 3BS12401

TABLE OF CONTENTS

SECTION	PAGE
Warranty	2
Product Specifications	2
Safety Instructions	3
Accessories and Attachments	6
Carton Contents	6
Know Your Band Saw	8
Glossary of Terms	9
Assembly and Adjustments	10
Operation	16
Maintenance	18
Troubleshooting guide	20
Parts	22

PRODUCT SPECIFICATIONS

MOTOR

Power source	120 V AC, 60 HZ, 7 AMPS
Horsepower	1 HP (Max. developed)
Speeds Low	1410 F.P.M.
	(Feet per minute)
High	2600 F.P.M.
Type	Induction

DRIVE BELT A 26

CUTTING CAPACITY

Throat	12"
Height	5"

BLADE

Width	1/8", 1/4", 3/8", 1/2"
Length	80"

TABLE

Size	13" x 13"
Tilt	0 - 45° Right

DUST COLLECTION Yes

NET WEIGHT 145.5 LB (66 Kg.)

⚠ WARNING

To avoid electrical hazards, fire hazards, or damage to the tool, use proper circuit protection.

Use a separate electrical circuit for your tools.

Your band saw is wired at the factory for 120V operation.

Connect to a 120V, 15 AMP time delay fuse or circuit breaker. To avoid shock or fire, replace power cord immediately if it is worn, cut or damaged in any way.

WARNING

⚠ WARNING

Some dust created by power sanding sawing, grinding, drilling, and other construction activities contains chemicals known [to the State of California] to cause cancer, birth defects or other reproductive harm. Some examples of these chemicals are:

- Lead from lead-based paints.
- Crystalline silica from bricks and cement and other masonry products, and
- Arsenic and chromium from chemically-treated lumber.

Your risk from these exposures varies, depending on how often you do this type of work. To reduce your exposure to these chemicals: work in a well ventilated area, and work with approved safety equipment, such as those dust masks that are specially designed to filter out microscopic particles.

SAFETY

GENERAL SAFETY INSTRUCTIONS BEFORE USING THE BAND SAW

Safety is a combination of common sense, staying alert and knowing how to use your band saw.

▲ WARNING

To avoid mistakes that could cause serious injury, do not plug the band saw in until you have read and understood the following:

1. **READ** and become familiar with this entire instruction manual. LEARN the tool's applications, limitations, and possible hazards.
2. **KEEP GUARDS IN PLACE** and in working order.
3. **REMOVE ADJUSTING KEYS AND WRENCHES.** Form the habit of checking to see that keys and adjusting wrenches are removed from the tool before turning ON.
4. **KEEP WORK AREA CLEAN.** Cluttered areas and benches invite accidents.
5. **DON'T USE IN A DANGEROUS ENVIRONMENT.** Don't use power tools in damp or wet locations, or expose them to rain. Keep work area well lit.
6. **KEEP CHILDREN AWAY.** All visitors should be kept at a safe distance from the work area.
7. **MAKE WORKSHOP KID-PROOF** with padlocks, master switches, or by removing starter keys.
8. **DON'T FORCE THE TOOL.** It will do the job better and safer at the rate for which it was designed.
9. **USE THE RIGHT TOOL.** Don't force the tool or the attachment to do a job for which it was not designed.
10. **USE PROPER EXTENSION CORD.** Make sure your extension cord is in good condition. When using an extension cord, be sure to use one heavy enough to carry the current your product will draw. An undersized cord will result in a drop in line voltage and loss of power which will cause the tool to overheat. The table on page 5 shows the correct size to use depending on cord length and nameplate ampere rating. If in doubt, use the next heavier gauge. The smaller the gauge number, the heavier the cord.
11. **WEAR PROPER APPAREL.** DO NOT wear loose clothing, gloves, neckties, rings, bracelets, or other jewelry which may get caught in moving parts. Non-slip footwear is recommended. Wear protective hair covering to contain long hair.
12. **WEAR YOUR SAFETY GOGGLES.**  **ALWAYS WEAR EYE PROTECTION.** Any band saw can throw foreign objects into the eyes which could cause permanent eye damage. ALWAYS wear Safety Goggles (not glasses) that comply with ANSI safety standard Z87.1. Everyday eyeglasses have only impact-resistant lenses. They ARE NOT safety glasses. Safety Goggles are available at Sears. **NOTE:** Glasses or goggles not in compliance with ANSI Z87.1 could seriously hurt you when they break.
13. **WEAR A FACE MASK OR DUST MASK.** Sawing operation produces dust.
14. **SECURE WORK.** Use clamps or a vise to hold work when practical. It's safer than using your hand and it frees both hands to operate tool.
15. **DISCONNECT TOOLS** before servicing, and when changing accessories, such as blades, bits, cutters, and the like.
16. **REDUCE THE RISK OF UNINTENTIONAL STARTING.** Make sure the switch is in OFF position before plugging in.
17. **USE RECOMMENDED ACCESSORIES.** Consult the owner's manual for the recommended accessories. The use of improper accessories may cause risk of injury to persons.
18. **NEVER STAND ON TOOL.** Serious injury could occur if the tool is tipped or if the cutting tool is unintentionally contacted.
19. **CHECK FOR DAMAGED PARTS.** Before further use of the tool, a guard or other part that is damaged should be carefully checked to determine that it will operate properly and perform its intended function. Check for alignment of moving parts, binding of moving parts, breakage of parts, mounting, and any other conditions that may affect its operation. A guard or other part that is damaged should be properly repaired or replaced.
20. **NEVER LEAVE TOOL RUNNING UNATTENDED. TURN THE POWER OFF.** Don't leave the tool until it comes to a complete stop.
21. **DON'T OVERREACH.** Keep proper footing and balance at all times.
22. **MAINTAIN TOOLS WITH CARE.** Keep tools sharp and clean for best and safest performance. Follow instructions for lubricating and changing accessories.
23. **DO NOT** use power tools in the presence of flammable liquids or gases.

SAVE THESE INSTRUCTIONS

24. **DO NOT** operate the tool if you are under the influence of any drugs, alcohol or medication that could affect your ability to use the tool properly.
25. **ALWAYS** operate the band saw in a well-ventilated area and provide for proper dust removal. Use dust collection systems whenever possible. Dust generated from certain materials can be hazardous to your health.

SPECIFIC SAFETY INSTRUCTIONS

1. **TO AVOID INJURY** from unexpected movement, make sure the saw is on a firm, level surface, properly secured to prevent rocking. Make sure there is adequate space for operating. Bolt the saw to a support surface to prevent slipping, walking, or sliding during operation.
2. **TURN** the saw OFF and unplug the saw before moving it.
3. **USE THE CORRECT** size and style of blade.
4. **USE** blades recommended at 2700 FPM or greater.
5. **MAKE SURE** the blade teeth point down and towards the table.
6. **BLADE GUIDES, SUPPORT BEARINGS AND BLADE TENSION** must be properly adjusted to avoid accidental blade contact and to minimize blade breakage. To maximize blade support, always adjust the upper blade guide and blade guard so that it is 1/8 inch above the workpiece.
7. **TABLE LOCK HANDLE** should be tight.
8. **USE EXTRA CAUTION** with large, very small or awkward workpieces.
9. **USE EXTRA SUPPORTS** to prevent workpieces from sliding off the table top. Never use another person in place of a table extension, or to provide additional support for the workpiece.
10. **WORKPIECES** must be secured so they don't twist, rock, or slip while being cut.
11. **PLAN** intricate and small work carefully to avoid pinching the blade. Avoid awkward operation and hand positions to prevent accidental contact with the blade.
12. **SMALL PIECES** should be secured with jigs or fixtures. Do not hand hold pieces that are so small your fingers are under the blade guard.
13. **SUPPORT** round work properly (with a V-block or clamped to the miter gauge) to prevent it from rolling and the blade from biting.

14. **CUT** only one workpiece at a time. Make sure the table is clear of everything except the workpiece and its guides before you turn the saw on.
15. **ALWAYS WATCH** the saw run before each use. If there is excessive vibration or unusual noise, stop immediately. Turn the saw off. Unplug it immediately. Do not start the saw again until the problem has been located and corrected.
16. **TO FREE** any jammed material, turn the switch OFF. Remove the switch key and unplug the saw. Wait for all moving parts to stop before removing jammed material.
17. **DON'T LEAVE** the work area until all moving parts are stopped. To childproof the workshop, shut off the power to master switches and remove the switch key from the band saw. Store it in a safe place, away from children.

▲ WARNING

For your own safety, read the entire instruction manual before operating the band saw.

1. Wear eye protection.
2. Do not wear gloves, necktie, or loose clothing.
3. Make sure the saw is on a firm level surface and properly secured.
4. **USE ONLY THE RECOMMENDED ACCESSORIES.**
5. Use extra caution with very large, very small, or awkward workpieces.
6. Keep hands away from the blade at all times to prevent accidental injury.
7. Do not remove jammed cutoff pieces until the blade has stopped.
8. Maintain proper adjustment of blade tension, blade guides, and thrust bearings.
9. Adjust upper guide to just clear the workpiece.
10. Hold the workpiece firmly against the table.

SAVE THESE INSTRUCTIONS

ELECTRICAL REQUIREMENTS

POWER SUPPLY AND MOTOR SPECIFICATIONS

⚠ WARNING

To avoid electrical hazards, fire hazards, or damage to the tool, use proper circuit protection. Use a separate electrical circuit for your tools. Your saw is wired at the factory for 120V operation. Connect to a 120V, 15 Amp circuit and use a 15 Amp time delay fuse or circuit breaker. To avoid shock or fire, if power cord is worn or cut, or damaged in any way, have it replaced immediately.

GROUNDING INSTRUCTIONS

⚠ WARNING

This tool must be grounded while in use to protect the operator from electrical shock.

IN THE EVENT OF A MALFUNCTION OR BREAKDOWN, grounding provides a path of least resistance for electric current and reduces the risk of electric shock. This tool is equipped with an electric cord that has an equipment grounding conductor and a grounding plug. The plug **MUST** be plugged into a matching receptacle that is properly installed and grounded in accordance with ALL local codes and ordinances.

DO NOT MODIFY THE PLUG PROVIDED. If it will not fit the receptacle, have the proper receptacle installed by a qualified electrician.

IMPROPER CONNECTION of the equipment grounding conductor can result in risk of electric shock. The conductor with the green insulation (with or without yellow stripes) is the equipment grounding conductor. If repair or replacement of the electric cord or plug is necessary, **DO NOT** connect the equipment grounding conductor to a live terminal.

CHECK with a qualified electrician or service person if you do not completely understand the grounding instructions, or if you are not sure the tool is properly grounded.

USE ONLY 3-wire extension cords that have 3-prong grounding plugs and 3-pole receptacles that accept the tool's plug. Repair or replace damaged or worn cord immediately.

Use a separate electrical circuit for your tools. This circuit must not be less than #12 wire and should be protected with a 15 Amp time lag fuse. Before connecting the motor to the power line, make sure the switch is in the OFF position and the electric current is rated the same as the current stamped on the motor nameplate. Running at a lower voltage will damage the motor.

This tool is intended for use on a circuit that has a receptacle like the one illustrated in FIGURE A. **FIGURE A** shows a 3-prong electrical plug and receptacle that has a grounding conductor. If a properly grounded receptacle is not available, an adapter (**FIGURE B**) can be used to temporarily connect this plug to a 2-contact ungrounded receptacle. The adapter (**FIGURE B**) has a rigid lug extending from it that **MUST** be connected to a permanent earth ground, such as a properly grounded receptacle box. **THE TEMPORARY ADAPTER SHOULD BE USED ONLY UNTIL A PROPER GROUNDED OUTLET CAN BE INSTALLED BY A QUALIFIED ELECTRICIAN.** The Canadian Electrical Code prohibits the use of adapters.

CAUTION: In all cases, make certain the receptacle is properly grounded. If you are not sure have a qualified electrician check the receptacle.

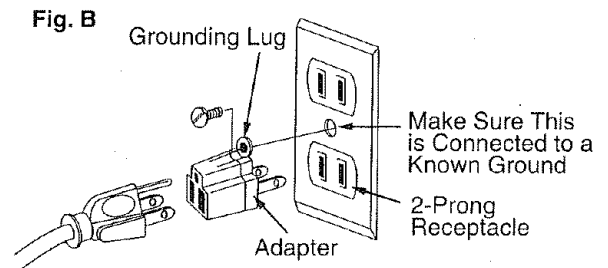
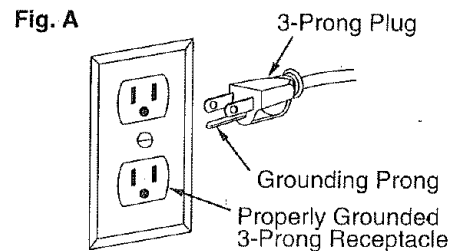

⚠ WARNING

This band saw is for indoor use only. Do not expose to rain or use in damp locations.

GUIDELINES FOR EXTENSION CORDS

USE PROPER EXTENSION CORD. Make sure your extension cord is in good condition. When using an extension cord, be sure to use one heavy enough to carry the current your product will draw. An undersized cord will result in a drop in line voltage and in loss of power which will cause the tool to overheat. The table below shows the correct size to use depending on cord length and nameplate ampere rating. If in doubt, use the next heavier gauge. The smaller the gauge number, the heavier the cord.

SAVE THESE INSTRUCTIONS

Be sure your extension cord is properly wired and in good condition. Always replace a damaged extension cord or have it repaired by a qualified person before using it. Protect your extension cords from sharp objects, excessive heat and damp or wet areas.

MINIMUM GAUGE FOR EXTENSION CORDS (AWG)					
(when using 120 volts only)					
Ampere Rating		Total length of cord in feet			
more than	not more than	25'	50'	100'	150'
0	6	18	16	16	14
6	10	18	16	14	12
10	12	16	16	14	12
12	16	14	12	Not recommended	

SAVE THESE INSTRUCTIONS

ACCESSORIES AND ATTACHMENTS

RECOMMENDED ACCESSORIES

Visit your Sears Hardware Department or see the Sears Power and Hand Tool Catalog to purchase recommended accessories for this power tool.

⚠ WARNING

To avoid personal injury:

- Use only accessories recommended for this band saw.
- Follow instructions that accompany accessories. Use of improper accessories may cause hazards.
- Use only accessories designed for this band saw to avoid injury from thrown broken parts or workpieces.
- Do not use any accessory unless you have completely read the instruction or owner's manual for that accessory.

ITEM

Miter gauge

Blade width: 1/8", 1/4", 3/8", 1/2"

Blade length: 80"

CARTON CONTENTS

UNPACKING AND CHECKING CONTENTS

Carefully unpack the band saw and all its parts, and compare against the list below and the illustration on page 7. Place the saw on a secure surface and examine it carefully.

⚠ WARNING

- To avoid injury from unexpected starting, do not plug the power cord into a power source receptacle during unpacking and assembly. This cord must remain unplugged whenever you are assembling or adjusting the saw.
- Although compact, this saw is heavy. To avoid back injury, get help whenever you have to lift the saw.
- If any part is missing or damaged, do not plug the band saw in until the missing or damaged part is replaced, and assembly is complete.

TABLE OF LOOSE PARTS

ITEM	DESCRIPTION	QUANTITY
BAND SAW		
A.	Band saw with motor	1
B.	Table with insert	1
C.	Table trunnions	2
D.	Table hardware	
	Hex bolts	6
	Lock washers	6
	Table alignment pin	1
E.	Trunnion support bracket	1
F.	Trunnion support hardware	
	Long bolt	2
	Short hex. bolt	1
	Hex nut	1
	Table lock knobs	2
	Washers	2
G.	Miter gauge	1
H.	Sawdust port	1
	Hex bolts	2
	Washers	2
I.	Power cord hooks	2
	Phillips head bolts	2
J.	Hex. key	1
K.	Stand attachment hardware	
	Large washers	8
	Hex. nuts	4
	Long hex. bolts	4
LEG STAND		
L.	Leg stand top plate	1
M.	Legs	4
N.	Short lower brackets	2
O.	Long lower brackets	2
P.	Foot pads	4
Q.	Bag:	
	Carriage bolts	32
	Hex. nuts	32
	Washers	32

UNPACKING YOUR BAND SAW

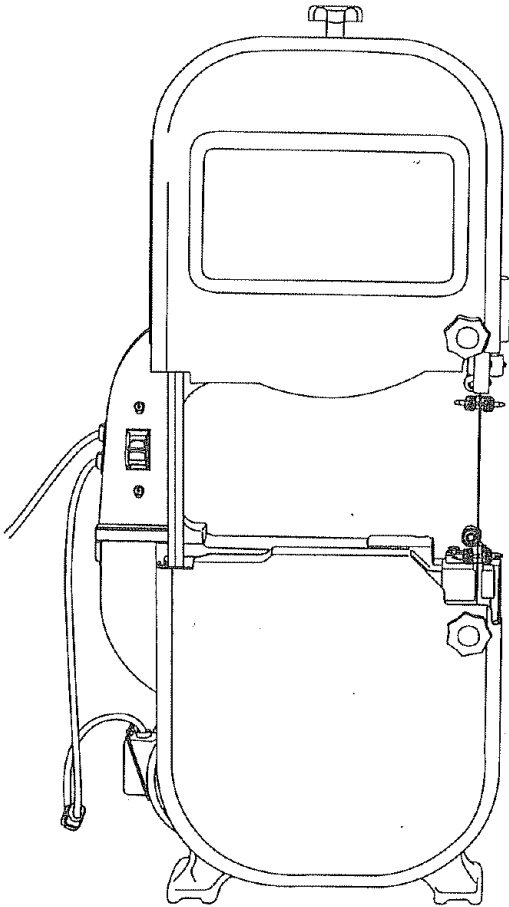

A

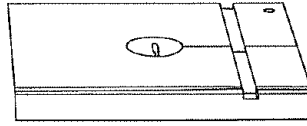

B



C



D

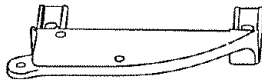

E



F

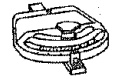

G

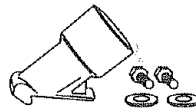

H

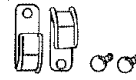

I



J

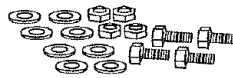

K



L

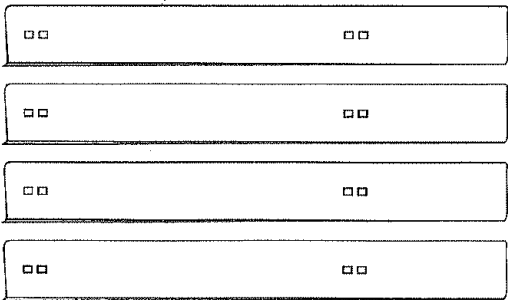

M

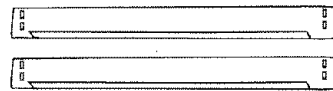

N

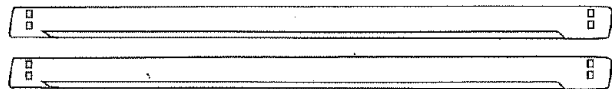

O



P

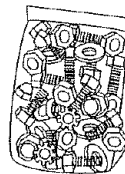

Q

KNOW YOUR BAND SAW

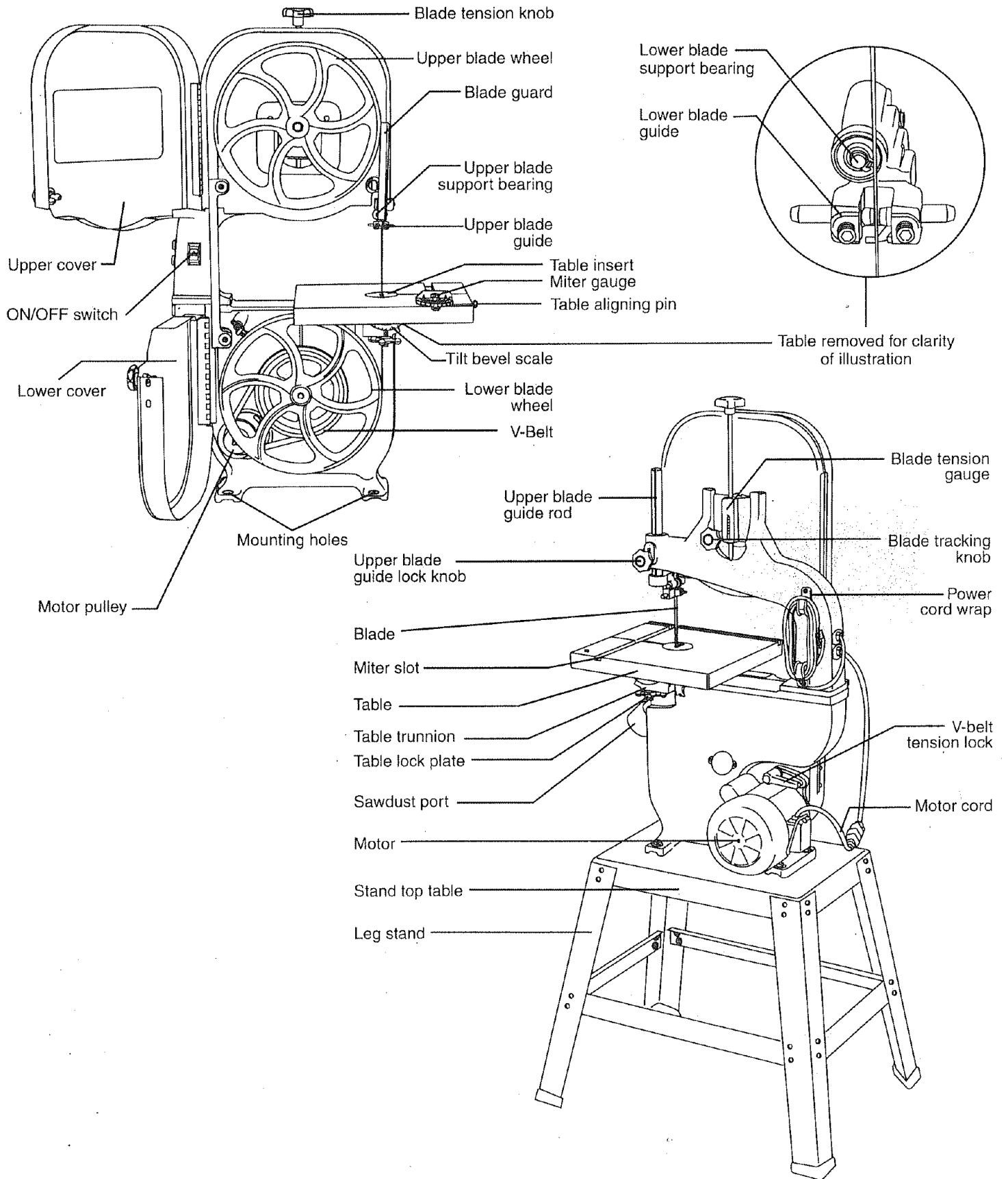

GLOSSARY OF TERMS

CRAFTSMAN BAND SAW TERMS

BLADE GUIDES – Support the blade and keep it from twisting during operation. Blade guides must be adjusted when the blade is changed or replaced.

BLADE TENSION KNOB – Controls the amount of blade tension when changing blades.

BLADE TRACKING KNOB – Adjusts the blade position so the blade always runs in the center of the wheel.

ON / OFF SWITCH – Has a built-in child safety lock. To lock the switch in the OFF position, remove the switch key from the switch.

RELIEF CUT – Removal of waste material by a cut from the outside edge, allowing easier cutting of intricate curves.

SAWDUST PORT – Helps keep the machine free from sawdust. The sawdust port makes an excellent hookup for a wet/dry vacuum.

TABLE LOCK KNOB – Locks the table in place.

TILT (BEVEL) SCALE – Shows the degree the table is tilted for bevel cutting.

UPPER BLADE GUIDE LOCK KNOB – Locks the upper slide. Use it after you adjust the upper guide assembly to make sure the upper blade guide just clears the workpiece before cutting. Upper guide lock knob must be tightened before the band saw is turned on.

WOODWORKING TERMS

BEVEL CUT – An angle cut made through the face of a workpiece

COMPOUND CUT – A simultaneous bevel and miter cut.

CROSSCUT – A cut made across the width of the workpiece.

F.P.M. – Feet per minute. Used in reference to the surface speed of the saw blade.

FREEHAND – Performing a cut without using a fence (guide), hold-down or other proper device to prevent the workpiece from twisting during the cutting operation.

GUM – A sticky sap based residue from wood products.

HEEL – Misalignment of the blade.

KERF – The material removed by a blade in a through cut, or the slot produced by the blade in a non-through or partial cut.

LEADING EDGE – The end of the workpiece pushed into the cutting tool first.

MITER CUT – An angle cut made across the width of a workpiece.

RELIEF CUT – Removal of waste material by a cut from the outside edge, allowing easier cutting of intricate curves.

RESAW – A cutting operation to reduce the thickness of the workpiece to make thinner workpieces.

RESIN – A sticky sap that has hardened.

RIPPING CUT – A cutting operation along the length of the workpiece.

R.P.M. – Revolutions per minute. The number of turns completed by a spinning object in one minute.

SAW BLADE PATH – The area of the workpiece or table top directly in line with the travel of the blade or the part of the workpiece which will be cut.

SET – The distance between two tips of the saw blade teeth, bent outward in opposite directions to each other.

TRAILING END – The workpiece end last cut by the blade.

WORKPIECE – The item being cut. The surfaces of a workpiece are commonly referred to as faces, ends, edges.

WORKTABLE – The surface on which the workpiece rests while performing a cutting or sanding operation.

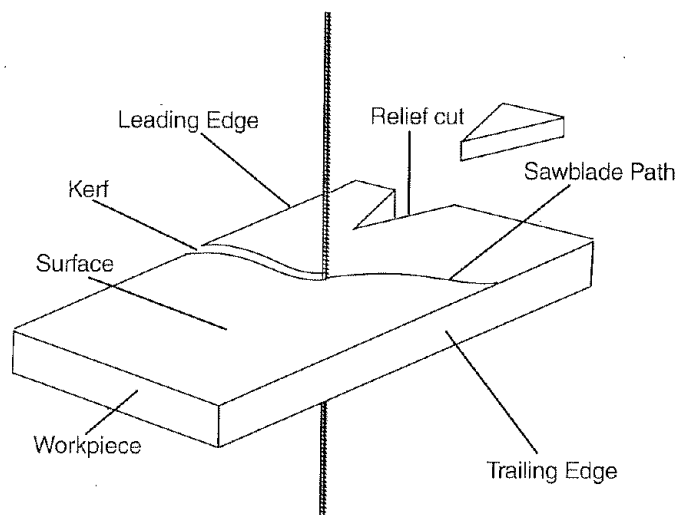

ASSEMBLY AND ADJUSTMENTS

ASSEMBLY INSTRUCTIONS

TOOLS NEEDED



Phillips screwdriver

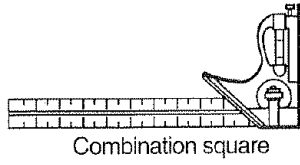

Combination square

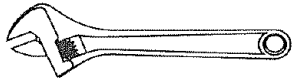

Adjustable wrench

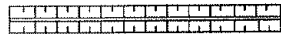

Straight edge



Feeler gauge - size 0.02

▲ WARNING

For your safety, never connect plug to power source receptacle until all assembly and adjustment steps are completed, and you have read and understood the safety and operating instructions.

LEG STAND ASSEMBLY (FIG. A)

1. Lay the top plate (1) upside down on a flat surface.
2. Attach a leg (2) to the outside of the stand top plate with four carriage bolts (3), washers (4), and nuts (5). Do not tighten.
3. Repeat for the remaining three legs.
4. Attach two long brackets (6) and two short brackets (7) to the inside of the legs, using carriage bolts (3), washers (4), and nuts (5). Do not tighten.
5. Place the leg pads (8) on each leg and turn the leg stand upright on a firm level surface.
6. Adjust the stand for stability.

FIG. A

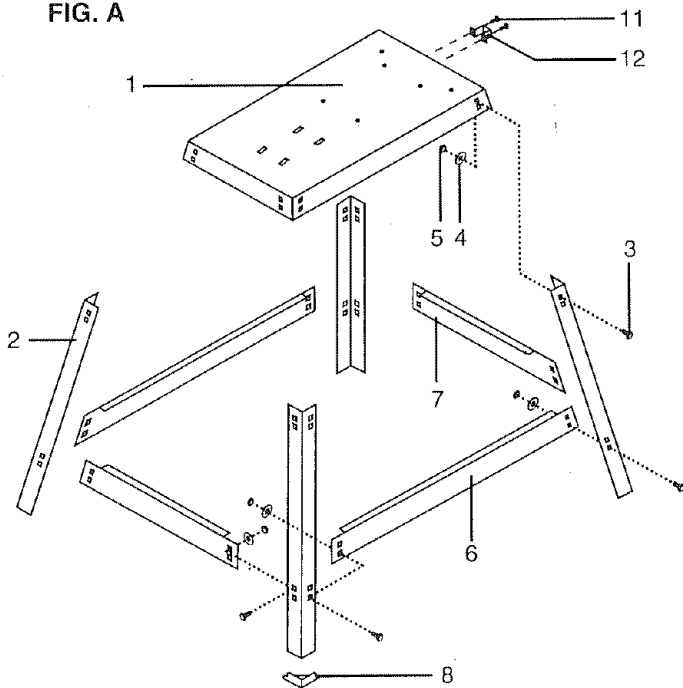

▲ WARNING

Although compact, this saw is heavy. To avoid back injury, get help to lift the saw.

ASSEMBLE BAND SAW TO LEG STAND (FIG. B)

1. Lift the saw body (1) and place on the leg stand (2), aligning the mounting holes (3) of the saw base with the four mounting holes of the leg stand top plate.
2. Attach the band saw to the stand with four long hex head bolts (4) and four flat washers (5).
3. Place a flat washer (5) and hex nut (6) on each bolt from the underside. Hand tighten.
4. Tighten all mounting bolts and nuts with a wrench.
5. Tighten all leg stand bolts and nuts with the wrench.

FIG. B

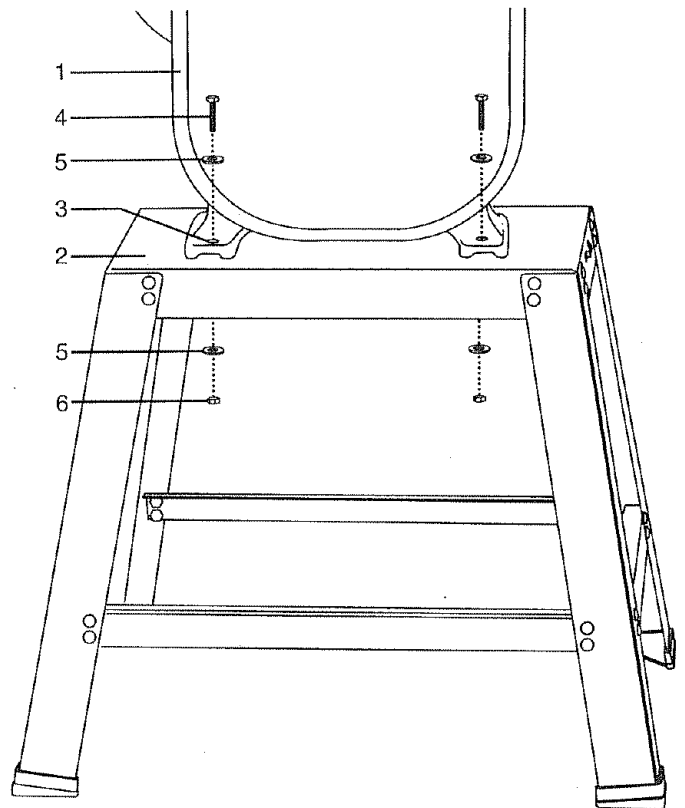

THE SAWDUST PORT (FIG. C)

The sawdust port has a 2-1/2" (O.D)/2-1/4" (I.D) diameter opening, suitable for attaching to a wet / dry vacuum hose, to help keep the work area free of sawdust.

1. Remove the bolts (1) and washers (2) from the sawdust port (3).
2. Open the lower wheel cover (4).
3. Attach the sawdust port to the edge of the wheel cover, using the same hex. head bolts and washers.
4. Tighten the bolts and close the cover.

FIG. C

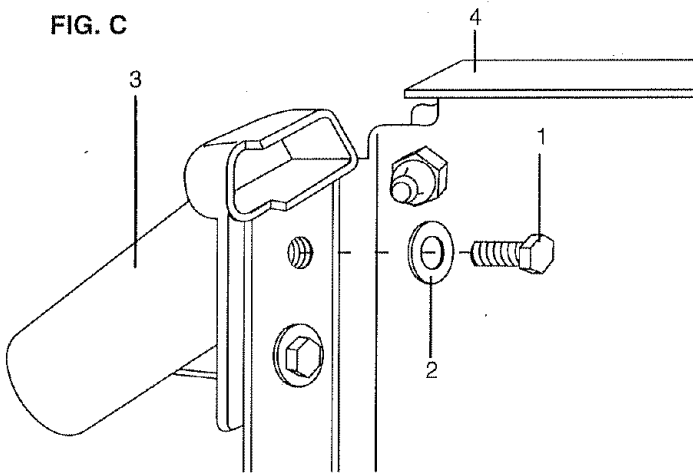

ASSEMBLE THE BAND SAW TABLE (FIG. D, E, F, G)

Mounting the trunnion support bracket (FIG. D)

1. Remove the two hex head bolts (1) and washers (2), located on the lower band saw housing.
2. Place the trunnion support bracket (3) on the saw body, as shown, aligning the mounting holes.
3. Place the washers on the hex head bolts, and insert into the threaded holes, through the bracket and saw body. Tighten.
4. Thread a nut (4) onto the table stop bolt (5) and screw both into the rear tab (6) on the trunnion support bracket.
5. Tighten the nut down onto the bracket tab.

FIG. D

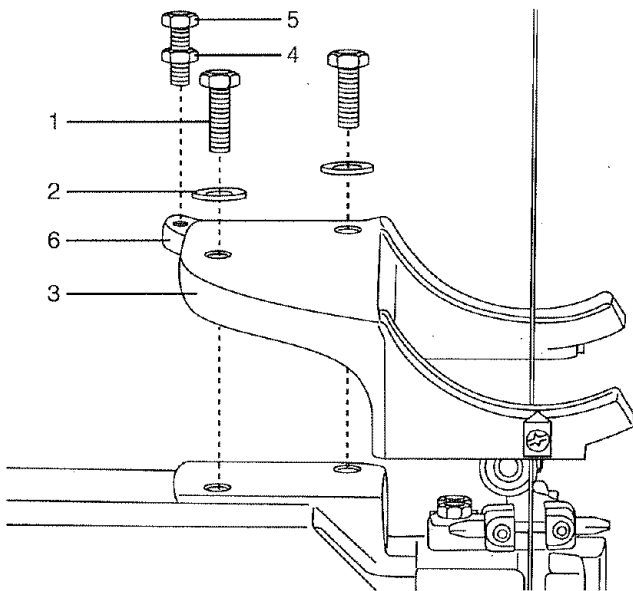

Mounting the table (FIG. E, F, G)

6. On the underside of the table (7), place the scale brackets (8) on the bracket mounting holes (9).
7. Be sure the long lock knob bolts (10) are placed upwards through the bracket slots as shown.
8. Place lock washers (11) on three short hex head bolts (12). Thread the bolts through the mounting holes and tighten.

FIG. E

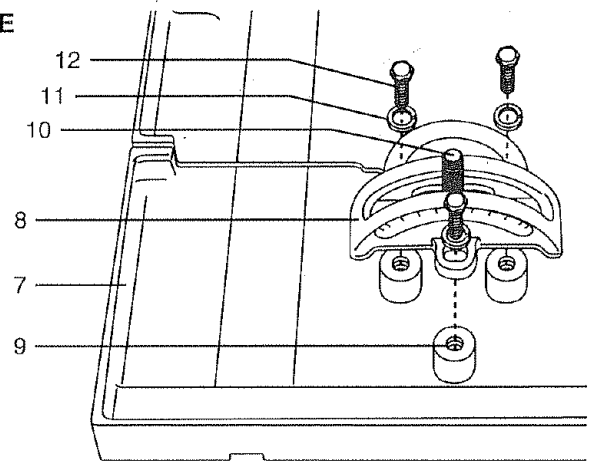

9. Turn the table right side up.
10. Remove the table insert (13) from the table.
11. Guide the table slot (14) over the saw blade and rotate a 1/4 turn, so the slot is perpendicular to the blade.
12. Placing the scale lock knob bolts (10) through the trunnion bracket holes (15) as shown, lower the table onto the trunnion bracket.

FIG. F

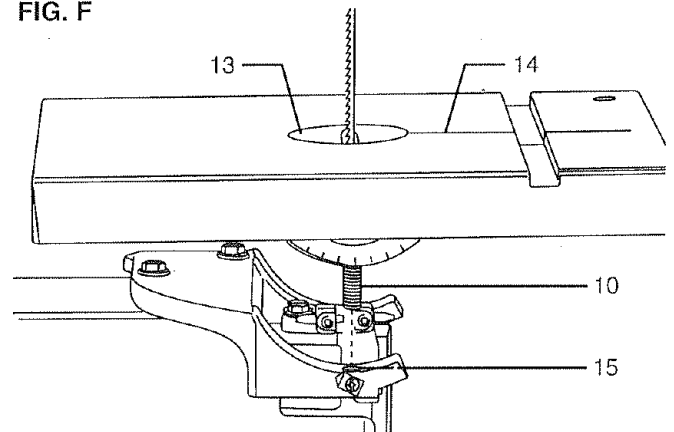

13. Place a lock knob (16) on each scale knob bolt. Adjust the table by aligning the zero scale mark to the scale pointer (17), and tighten the knobs.
14. Replace the table insert (13), aligning the indents.
15. Place the table aligning pin (18) in the hole at the front of the table, and tighten.

FIG. G

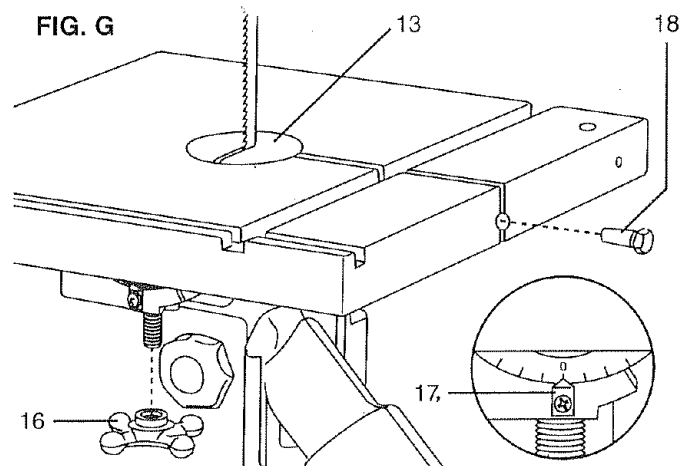

INSTALLING AND REMOVING BLADES (FIG. H)

▲ WARNING

To avoid injury from accidental starting, always turn the switch OFF and remove the plug from the power source before moving, replacing, or adjusting the blade.

Removing

1. Loosen the blade tension by turning the blade tension knob (1) counterclockwise.
2. Remove the table insert (2) and remove the table aligning pin (3) from the table.
3. Open the upper and lower wheel cover doors (4).
4. Loosen the two Phillips screws (5) and remove the upper blade guard (6).
5. Remove the blade (7) from the upper and lower blade guides (8).
6. Carefully pull the blade from the side slot (9) and from the wheels (10).
7. Swing the left side of the blade toward you, turning the blade so it will fit through the slot (11) in the table, and remove.

FIG. H

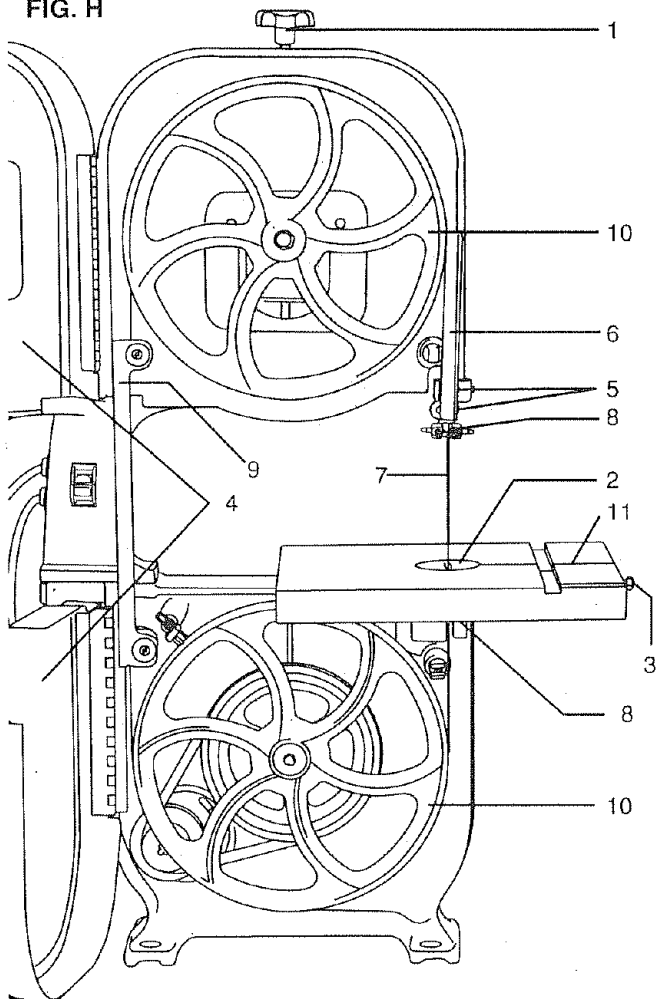

Installing

1. Make sure the blade tension knob (1) is turned counterclockwise until it stops.
2. Remove old blade as explained in "Removing".
3. Guide the new blade (7) through the table slot (11). Make sure the blade teeth are pointing forward and down.

NOTE: To avoid lifting the workpiece, the blade teeth must point downward toward the table.

4. Swinging the left side off the blade away and back, place the blade on the upper and lower wheels (10).
5. Place the blade carefully between the upper and lower blade guides (8).
6. Slide the blade into the slot (9) at the left of the wheels, and make sure the blade is positioned at the middle of the wheels.
7. Turning the blade tension knob (1) clockwise, tighten the tension until the blade is tight on the wheels.
8. Replace the table insert (2) and the table aligning pin (3).
9. Adjust the blade tracking and tension properly (See ADJUSTMENT INSTRUCTIONS section) before operating the band saw.

▲ WARNING

To avoid injury, the blade tension, tracking, and upper and lower guides and bearings must be properly adjusted before operating the band saw. (See ADJUSTMENT INSTRUCTIONS section)

MITER GAUGE (FIG. I)

A miter gauge (1) is supplied with your band saw to be used in the table slot (2) on the right side of the blade. The miter gauge can be tilted 0° to 45° right or left, to maintain an accurate angle for your workpiece. A bracket is provided on the leg stand for convenient miter gauge storage.

FIG. I

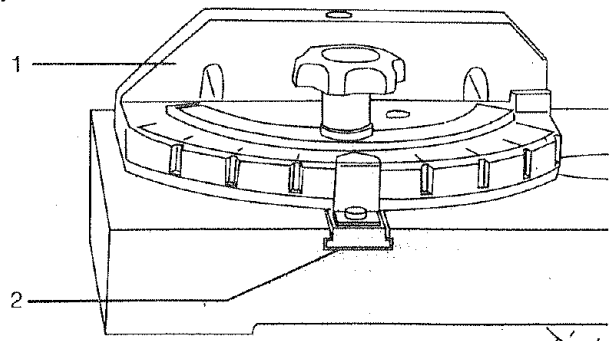

▲ WARNING

Before operation always make sure the blade is in center of table insert slot.

INSTALL POWER CORD BRACKETS (FIG. J)

1. Power cord brackets (1) are provided for convenient cord storage. Attach the power cord brackets to the back of the saw body, as shown, with two Phillips head screws (2). Tighten.
2. Wrap the power cord onto the brackets when the band saw is not in use, to prevent damage to the cord.

FIG. J

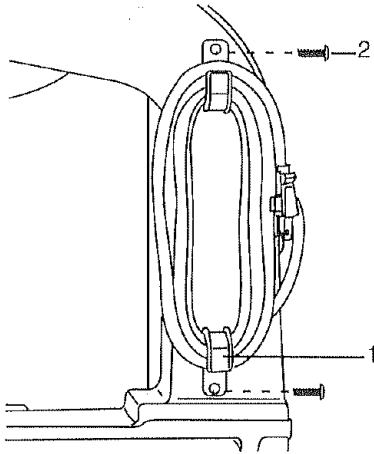

Adjusting the 90° table stop (FIG. L)

1. Loosen the table lock knobs (2) and tilt the table to the right.
2. Loosen the nut (4) on the table stop bolt (5) and lower the stop bolt as far as possible.
3. Tilt the table until it rests on the stop bolt.
4. Place a combination square (6) on the table with the heel of the square against the saw blade.
5. Adjust the tilt of the table left or right until it is 90° to the blade. Make sure there is no space between the square and the blade. Tighten the table lock knobs.
6. Adjust the table stop bolt up until it touches the table. Tighten the jam nut down to the support bracket.
7. Loosen the lock knobs and see that the table is resting on the stop bolt.
8. Check the square to make sure the table is still square to the blade. If not, readjust the stop bolt.
9. When the adjustment is accurate at 90°, align the pointer (7) to 0° on the scale (8).

FIG. L

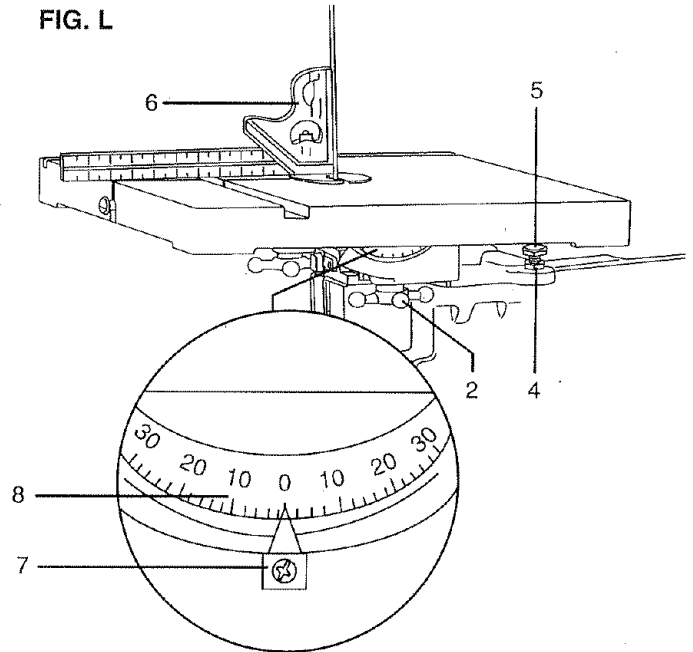

ADJUSTMENT INSTRUCTIONS

⚠ WARNING

To avoid injury, turn the switch OFF and unplug the band saw from the power source before making any adjustments.

TABLE ADJUSTMENTS (FIG. K, L)

Tilting the table (FIG. K)

The band saw table (1) tilts 0° to 45° to the right

1. Loosen both table lock knobs (2) underneath the table.
2. Tilt the table to the desired angle on the scale (3) underneath the table.
3. Tighten the two table lock knobs.

FIG. K

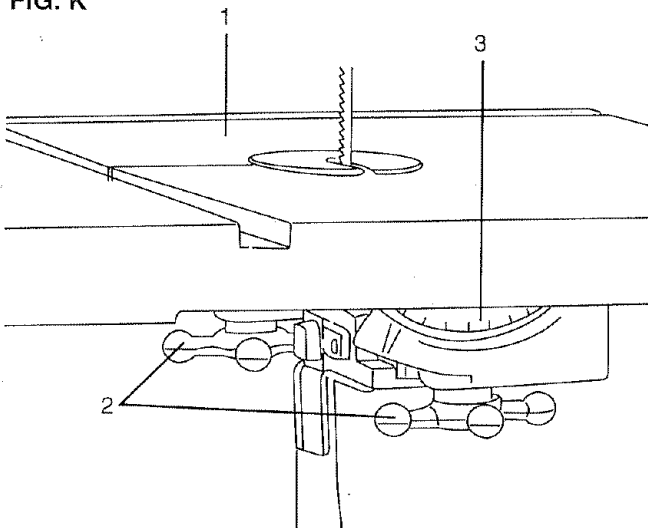

BLADE TENSION (FIG. M)

⚠ WARNING

To avoid injury, turn the switch OFF and disconnect the saw from the power source before making any adjustments. NEVER make tension adjustments with the machine running.

The gauge (1) on the bracket (2) at the rear of the upper wheel housing indicates the proper tension for the various blade widths.

1. Set the blade tension gauge to correspond with the width of the blade in use.
2. Turn the blade tension knob (3) clockwise, raising the upper wheel to tighten the blade. Turn the knob counterclockwise to lower the upper wheel, loosening the blade.
3. As you become familiar with the saw, you may want to change the tension settings.

NOTE: Changes in blade width and type of material being cut will have an effect on the blade tension. Too much or too little tension could break the blade. When the band saw is not in use, relax the blade tension.

FIG. M

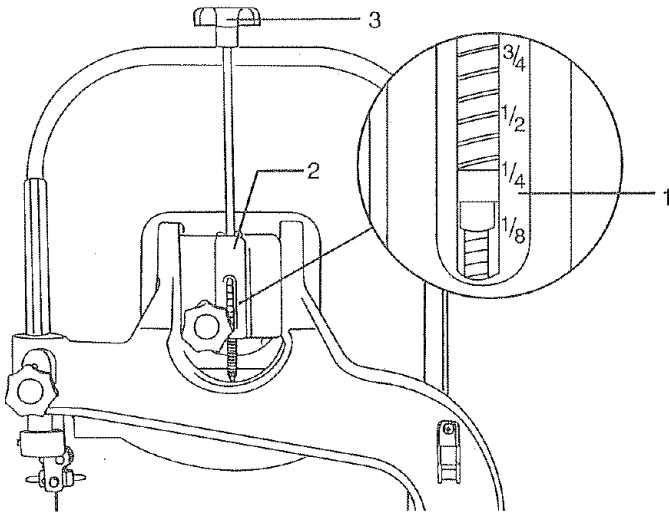

BLADE TRACKING (FIG. N)

⚠ WARNING

To avoid injury, turn the switch OFF and disconnect the saw from the power source before making any adjustments. NEVER make tension adjustments with the machine running.

1. The blade (1) must be tensioned properly before adjusting the tracking.
2. Open the upper cover.
3. Move the blade guides (2) and support bearings (3) away from the blade, if necessary. See page 15 for bearing and guide adjustment.
4. Rotate the wheel (4) slowly forward by hand, and check the position of the blade on the wheel. The blade should remain centered on the wheel as it turns.

5. If the blade moves toward the front of the wheel, turn the tracking knob (5) on the rear of the band saw clockwise. This tilts the top of the wheel and moves the blade toward the center.
6. If the blade moves toward the back edge, turn the tracking knob counterclockwise, moving the blade toward the center.

NOTE: Turn the tracking knob SLIGHTLY to make blade tracking adjustments.

FIG. N

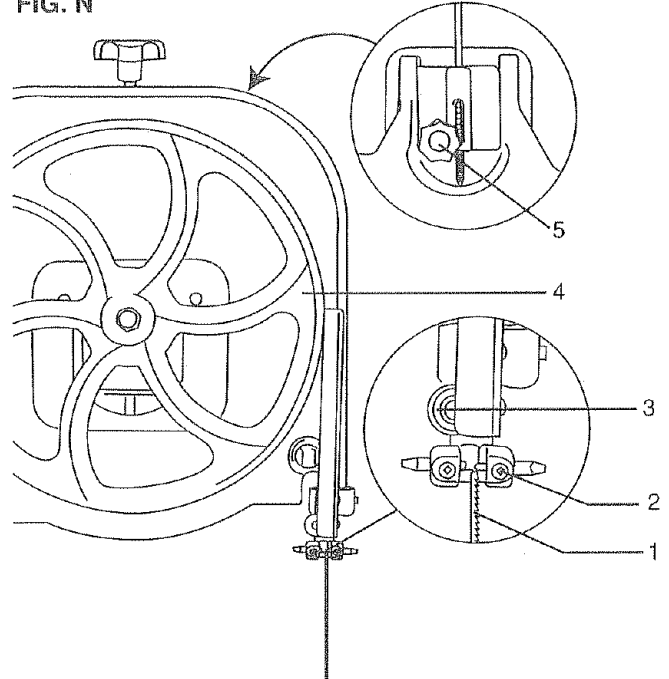

UPPER BLADE GUIDE ASSEMBLY (FIG. O)

⚠ WARNING

To avoid injury, turn the switch OFF and disconnect the saw from the power source before making any adjustments. NEVER make adjustments with the machine running.

1. Loosen the lock knob (1) and move the blade guide assembly (2) up or down to 1/8" above the workpiece.
2. Tighten the lock knob.

FIG. O

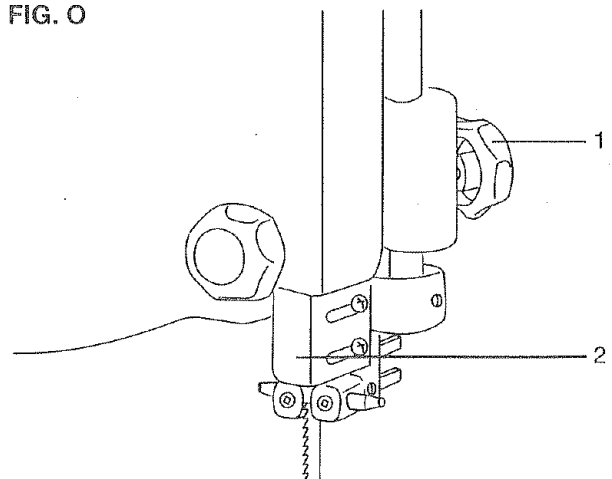

UPPER BLADE GUIDES AND BLADE SUPPORT BEARING (FIG. P, Q)

⚠ WARNING

- The blade guard has been removed for clarity of illustration. To avoid injury never operate the band saw without all guards in place and in working order.
- To avoid injury, turn the switch OFF and disconnect the saw from the power source before making any adjustments. NEVER make adjustments with the machine running.

NOTE: Make sure the blade is tensioned and tracking properly. Adjust the blade guides and support bearing after each blade tension and tracking adjustment. When the upper blade guides and support bearings are adjusted, the lower guides and bearings should also be adjusted.

Blade guides (FIG. P)

1. Make sure the blade is tensioned and tracking properly.
2. Loosen the front hex socket screws (1) with a hex wrench.
3. Move the guides (2) as close to the blade (3) as possible without pinching it.
4. Using a feeler gauge, make sure the space between each guide and the blade measures 0.02" (the thickness of a dollar bill)
5. Tighten the hex socket screws.
6. Loosen the side hex socket screw (4) by turning counterclockwise.
7. Move the blade guide bracket shaft (5) in or out until the guides are at least 1/32" behind the blade teeth.
8. The guides must remain behind the blade teeth during operation to prevent damage to the saw blade.
9. Tighten the hex socket screw.

FIG. P

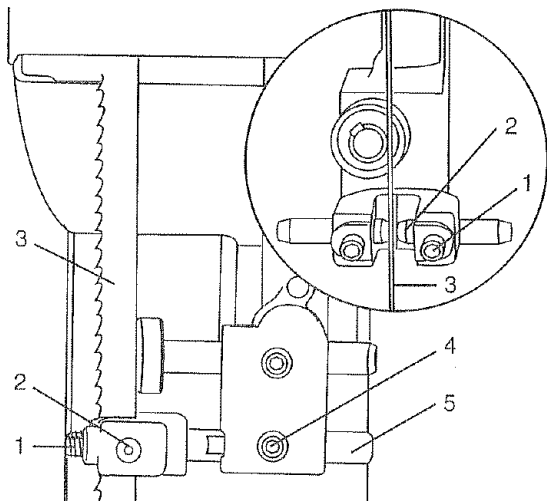

Support bearing (FIG. Q)

10. Loosen the bearing hex socket screw (6).
11. Move the support bearing shaft (7) in or out, until the bearing (8) is 1/64" behind the blade.
12. Tighten the hex socket screw (6).

NOTE: The blade support bearing prevents the blade from moving back too far and damaging the saw teeth setting.

FIG. Q

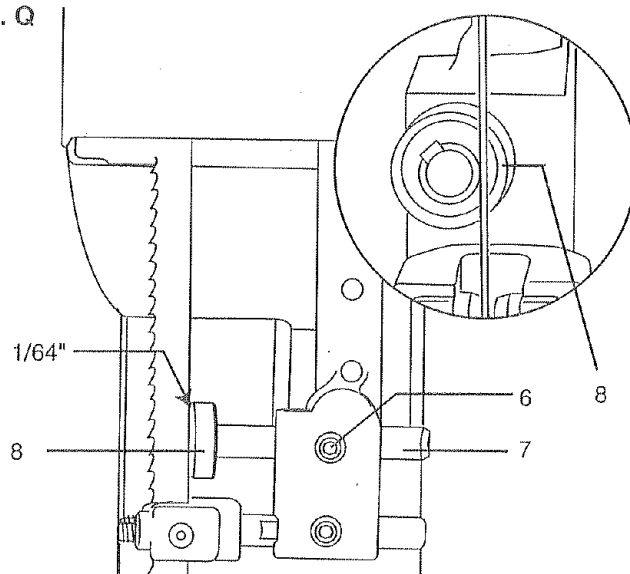

LOWER BLADE GUIDES AND SUPPORT BEARING

⚠ WARNING

To avoid injury, turn the switch OFF and disconnect the saw from the power source before making any adjustments. NEVER make adjustments with the machine running.

NOTE: Make sure the blade is tensioned and tracking properly.

The lower blade guides and support bearings should always be adjusted after the blade is tensioned, the tracking is adjusted, and the upper blade guides and upper support bearings are properly adjusted.

Blade guides (FIG. R)

1. Loosen both front hex socket screws (1) with a hex wrench.
2. Move the guides (2) as close to the sides of the blade (3) as possible without pinching it.
3. Using the feeler gauge, measure the spaces between the guides and the blade. Adjust to 0.02".
4. Tighten the hex screws.
5. Loosen the side hex socket screw (4). Move the guide support bracket (5) in or out until the guides are at least 1/32" behind the saw teeth. Tighten the screw.

FIG. R

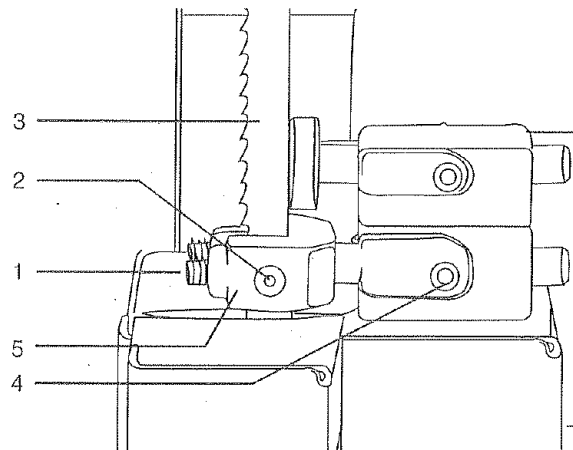

Support bearing (FIG. S)

- Loosen the bearing hex socket screw (7) with the hex wrench.
- Move the blade support bearing shaft (8) in or out until the support bearing (9) is 1/64" behind the saw blade.
- Tighten the bearing hex socket screw.

FIG. S

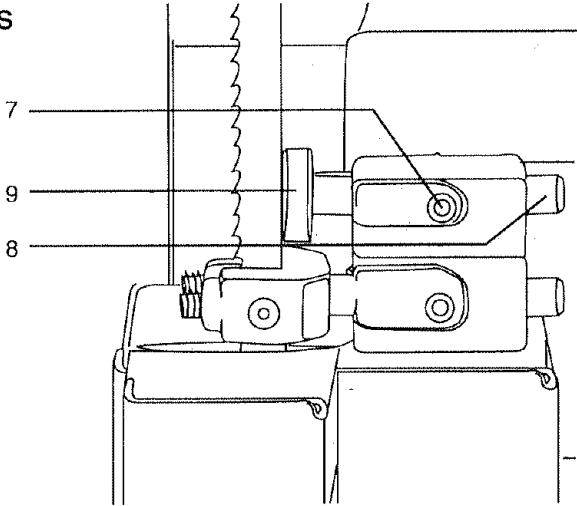

Pulley alignment (FIG. T)

The pulley alignment is adjusted properly at the factory and should not need readjustment.

If adjustment is needed, or the belt needs replacing:

- Place a straight edge in the front groove of both pulleys, behind the blade wheel.
- Turn the hex socket screw (1) in the side of the motor pulley (2) to loosen the pulley on the shaft.
- Adjust the motor pulley in or out on the motor shaft (3) to align the edges of the two pulleys.
- When aligned, tighten the hex socket screw on the side of the motor pulley.

FIG. T

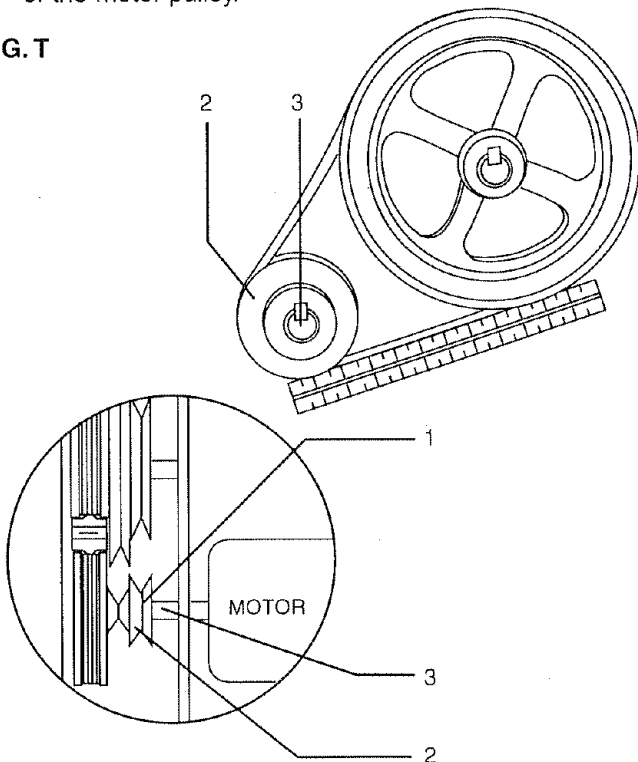

OPERATION

BASIC SAW OPERATIONS

ON / OFF SWITCH (FIG. U)

The keyed switch is intended to prevent unauthorized use of the band saw.

- To turn the band saw ON insert the yellow key (1) into the key slot (2) in the center of the switch.
- Push the key firmly into the slot, then push switch to the ON position to start the band saw.
- To turn the band saw OFF push the switch to the down position.
- Remove the yellow switch key, when the saw has come to a complete stop, by gently pulling it outward.

▲ WARNING

Remove the switch key whenever the saw is not in use. Place it in a safe place and out of reach of children.

FIG. U

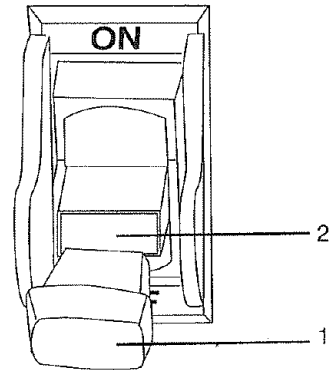

GENERAL CUTTING

▲ WARNING

For your safety, read and understand all GENERAL and SPECIFIC SAFETY INSTRUCTIONS on pages 3 - 5 before using the band saw.

Operating band saws involves a certain amount of hazard. Before attempting regular work, use scrap lumber to check the settings, and to get the feel of operating the band saw. Read instructions and plan your work before cutting a workpiece.

Do not turn the power ON until after you have made all adjustments, checked that the guard is in place, and turned the wheel by hand to make sure all parts work properly. Always keep the guide assembly close to your work, 1/8" above the workpiece.

Do not force the workpiece, against the blade. Light contact permits easier cutting and prevents unwanted friction and heating of the blade.

Sharp saw blades need little pressure for cutting. Steadily move the workpiece against the blade without forcing it.

To avoid twisting the blade, do not turn sharp corners, saw around corners.

A band saw is basically a "curve-cutting" saw. It is not capable of doing intricate inside cutting as can be done with a scroll saw.

It is also used for straight line operations such as crosscutting, ripping, mitering, beveling, compound cutting, and resawing.

⚠ WARNING

To avoid blade breakage, fire or other damage or injury, NEVER use this band saw to cut ferrous metals.

CUTTING CURVES

When cutting curves, carefully turn the workpiece so the blade follows without twisting. If the curve is so sharp that you repeatedly back up and cut new kerf, use a narrower blade, or a blade with more set (teeth further apart). When a blade has more set, the workpiece turns easier but the cut is rougher.

When changing a cut, do not withdraw the workpiece from the blade. The blade may get drawn off the wheels. To change a cut, turn the workpiece and saw out through the scrap material area.

When cutting long curves, make relief cuts as you go along.

CIRCLE CUTTING (FIG. V)

1. Adjust the guide assembly to 1/8" above the workpiece.
2. Use both hands while feeding the work into the blade. Hold the workpiece firmly against the table. Use gentle pressure. Do not force the work, ALLOW the blade to cut.
3. The smallest diameter circle that can be cut is determined by the width of the blade. For example, a 1/4" wide blade will cut a minimum diameter of approximately 1-1/2".

FIG. V

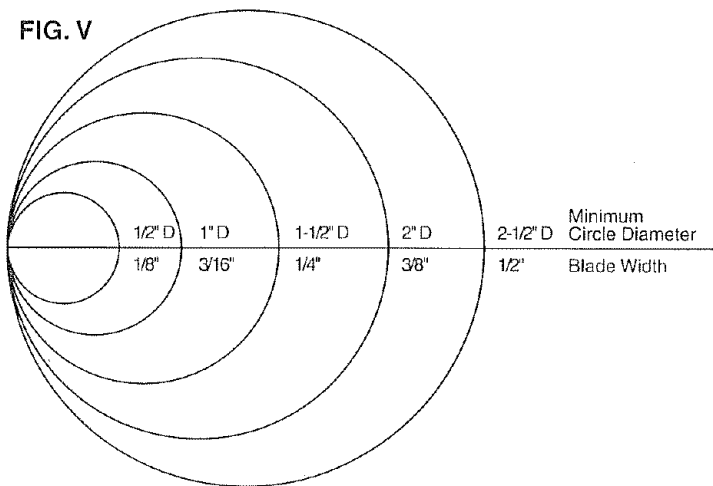

BLADE SELECTION (FIG. W)

CAUTION: Blade teeth are sharp. Use care when handling a saw blade.

For longest wear and best cutting results, use the correct blade thickness, width, and temper for the type of material you will cut.

When sawing small curves and delicate work, use narrow blades. Otherwise, use the widest blade possible. For cutting wood and similar materials with this bandsaw, purchase blades in widths up to 1/2", and a length of 80".

Do not cut ferrous metals with this band saw.

Common causes of blade breakage:

- Poor guide alignment and adjustment.
- Forcing or twisting a wide blade around a short radius.
- Feeding too fast.
- Dull teeth or not enough set.
- Too much blade tension.
- Setting top guide assembly too high above the workpiece.
- Lumpy or improperly finished braze or weld on the blade.
- Continuous running of blade when not cutting.

FIG. W

Operation	Recommended Blade Width (Inches)
Cross Cutting	1/4, 3/8, 1/2
Mitering	1/4, 3/8, 1/2
Beveling	1/4, 3/8, 1/2
Compound Cutting	1/4, 3/8, 1/2
Circle Cutting	See Fig. V
Curve Cutting	1/8, 1/4

BLADE SPEED SELECTION (FIG. X)

This band saw has two speed settings:

1. 2600 F.P.M. for normal operation.
2. 1410 F.P.M. for operation requiring more control.

RECOMMENDED SPEEDS

FIG. X

SPEED	APPLICATION	BLADE TYPE
2600 F.P.M.	1. Basic wood cutting 2. Resawing	1. Skip tooth type 2. Hook tooth type 3. Regular tooth blades
1410 F.P.M.	1. Intricate wood cutting 2. Veneers, tiles, plastics 3. Nonferrous metals; brass, copper, aluminum	15 teeth per inch blades



CHANGING SPEED SETTING (FIG. Y)

▲ WARNING

To avoid injury, turn the switch OFF and disconnect the saw from the power source before making any adjustments. NEVER make adjustments with the machine running.

1. Loosen the belt tension by turning the tension lock handle (6).
2. Open the lower wheel cover and reposition the V-belt (3).
 - A. Changing the speed from 1410 to 2600 FPM: Remove the belt (3) from the band saw pulley (4) first, and reposition in the saw pulley groove (1). Next, remove the belt from the motor pulley (5) and reposition in the motor pulley groove (1).
 - B. Changing the speed from 2600 to 1410 FPM: Remove the belt (3) from the motor pulley (5) first, and reposition in the motor pulley groove (2). Remove the belt from the saw pulley (4) and reposition in the saw pulley groove (2).
3. Tighten the belt tension by turning the tension lock handle (6).

NOTE: After readjusting belt position and belt tension, check and readjust the settings for the blade tension and tracking, guides and bearings (See ADJUSTMENT section).

FIG. Y

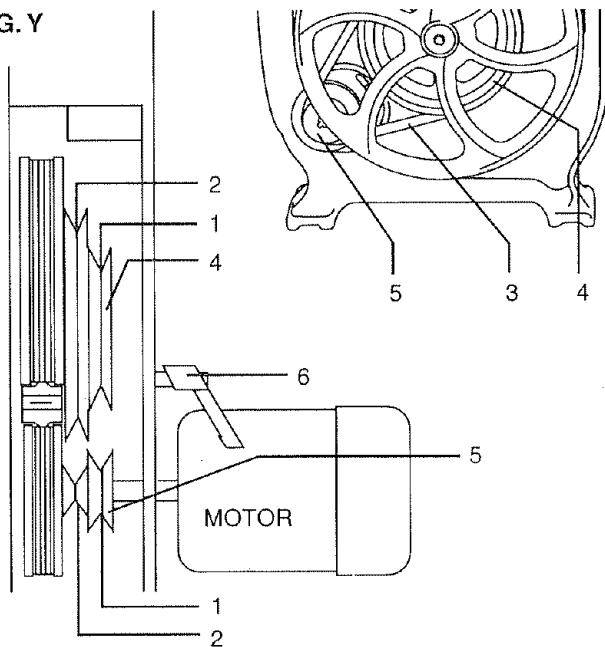

▲ WARNING

To avoid possible injury or damage, NEVER use this band saw to cut ferrous metals.

CAUTION: When cutting nonferrous metals, metal shavings can react with wood dust and start a fire. To avoid this:

1. Disconnect any dust collecting hose from the band saw.
2. Remove all traces of wood dust from inside the saw.
3. Remove all metal shavings from inside the saw before sawing wood again.

MAINTENANCE

GENERAL MAINTENANCE

▲ WARNING

- For your own safety, turn switch OFF and remove the plug from power source receptacle before maintaining, cleaning, adjusting, or lubricating your band saw.
- To avoid fire or toxic reaction, never use gasoline, naphtha, acetone, lacquer thinner or similar highly volatile solvents to clean the band saw.
- To avoid eye injury from blowing debris, wear safety goggles when blowing out sawdust.

BAND SAW

Sawdust will accumulate under the table and base. This could cause difficulty in the movement of the table when setting up a band saw cut, and also cause a fire hazard. Frequently blow out or vacuum up the sawdust.

Keep your band saw clean. Remove the sawdust from the inside. Vacuum or blow out frequently.

Do not allow filth to build up on the table, the guides, or the support bearings. Clean them with Craftsman Gum and Pitch Remover.

NOTE: Do not immerse the support bearings in the gum and pitch remover.

Put a thin coat of paste wax on the table so that the wood slides easily while cutting.

TO INSTALL A NEW BELT (FIG. Z)

1. Open the lower wheel door.
2. Loosen the blade tension by turning the blade tension lock knob (1).
3. Remove the blade from the lower blade wheel.
4. Loosen and remove the hex head bolt (2) and flange (3) on the lower blade wheel.
5. Remove the lower blade wheel.
6. Turn the belt tension handle (4) on the rear of the saw housing to loosen the v-belt tension.
7. Remove the v-belt (5).
8. Check the alignment of the two pulleys.
9. If the edges of the two pulleys are not aligned, see "ALIGN THE PULLEYS" in ADJUSTMENT section.
10. Place the new v-belt on the saw pulley and the motor pulley. See OPERATION section "CHANGING SPEED SETTINGS" on page for proper belt placement.
11. When positioned properly, tighten the v-belt tension by turning the tension lock handle.

NOTE: The pulley belt is properly tensioned when there is 1/2" deflection if pressed in the center between the pulleys.

12. Replace the blade wheel. Push the wheel on firmly until it is touching the saw pulley. Replace and tighten the flange and nut.
13. Reinstall the blade (See INSTALLING BLADES Section on page).
14. Adjust the blade tension, tracking, and the upper and lower blade guides and bearings before operating the band saw.

▲ WARNING

To avoid injury, the blade tension, tracking, and upper and lower guides and bearings must be properly adjusted before operating the band saw. (See ADJUSTMENT INSTRUCTIONS section)

FIG. Z

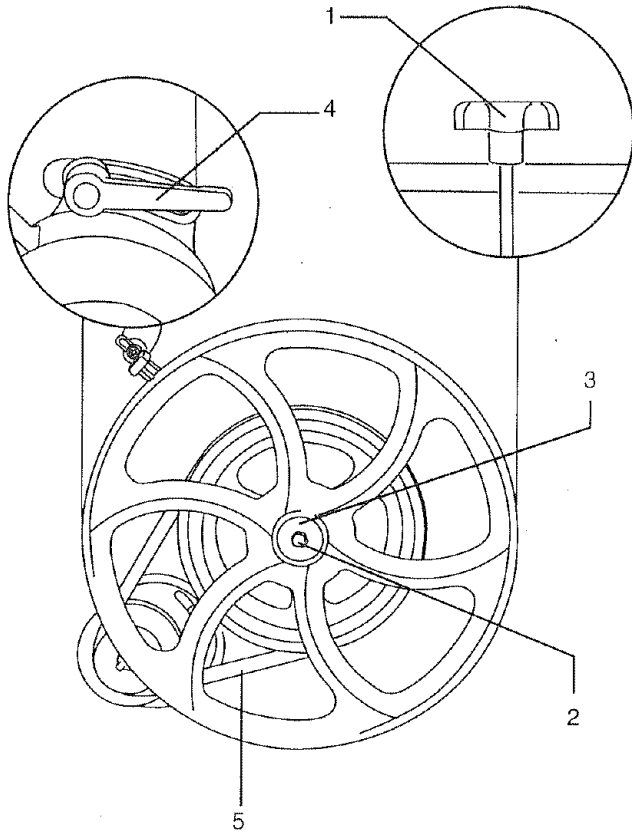

BLADE WHEEL TIRES

Pitch and sawdust that build up on the tires should be removed with a stiff brush or scrape off with a piece of wood.

NOTE: To avoid damaging the tires do not use a sharp knife or any kind of solvent.

When the tires become worn they should be replaced. When replacing the tires, stretch them around the wheels but do not glue them on.

MOTOR

Frequently blow or vacuum out any sawdust from the motor. Follow lubrication instruction on the motor label.

▲ WARNING

To avoid electrocution or fire, immediately replace a worn, cut or damaged power cord.

LUBRICATION

All of the bearings are packed with grease at the factory. They require no further lubrication.

CAUTION: Never put lubricants on the blade while it is spinning.



TROUBLESHOOTING

TROUBLESHOOTING GUIDE

▲ WARNING

- To avoid injury from an accidental start, turn the switch OFF and always remove the plug from the power source before making any adjustments.
- All electrical or mechanical repairs should be done only by qualified service technicians. Contact the nearest Sears Service Center.

GENERAL

Problem	Probable Cause	Remedy
Blade does not run in the center of the upper wheel.	<ol style="list-style-type: none"> 1. Not tracking properly. 2. Defective blade. 	<ol style="list-style-type: none"> 1. Adjust tracking. See ASSEMBLY AND ADJUSTMENTS section "BLADE TRACKING". 2. Replace blade.
Band saw slows down when cutting.	<ol style="list-style-type: none"> 1. Belt too loose. 2. Cutting too small a radius. 3. Dull blade. 4. Overloading motor. 	<ol style="list-style-type: none"> 1. Adjust belt tension. See ASSEMBLY AND ADJUSTMENTS section "BLADE TENSION". 2. Stop feeding, back up the material slightly, until the band saw speeds up. 3. Replace blade. 4. Slow down, you are trying to cut too fast. See "MOTOR TROUBLESHOOTING GUIDE".
Blades braking.	<ol style="list-style-type: none"> 1. Too much tension on the blade. 2. Kink in the blade caused by cutting too small a radius or turning the material too fast when cutting. 	<ol style="list-style-type: none"> 1. Adjust tension. See ASSEMBLY AND ADJUSTMENTS section "BLADE TENSION" 2. Use correct cutting technique. See OPERATION section "GENERAL CUTTING".
Blade dulls too quickly.	<ol style="list-style-type: none"> 1. Blade guides set too close to the teeth. 2. Cutting incorrect material. 	<ol style="list-style-type: none"> 1. Adjust upper and lower blade guides. 2. See OPERATION section "BLADE SELECTION".
Band saw vibrates.	<ol style="list-style-type: none"> 1. Too much tension on motor belt. 	<ol style="list-style-type: none"> 1. Adjust according to ASSEMBLY AND ADJUSTMENTS section, "INSTALL THE BELT".

MOTOR

Problem	Probable Cause	Remedy
Noisy operation.	<ol style="list-style-type: none"> 1. Incorrect belt tension. 2. Loose motor pulley. 3. Loose pulley cover. 	<ol style="list-style-type: none"> 1. Adjust tension. See ASSEMBLY AND ADJUSTMENTS section "INSTALL THE BELT". 2. Readjust and tighten motor pulley set screw. 3. Readjust and tighten pulley cover mounting screws.
Motor will not start.	<ol style="list-style-type: none"> 1. Not plugged into power outlet. 2. Switch and key not in ON position. 3. Motor cord cut or abraded. 4. Plug on cord is faulty. 5. Fuse on circuit breaks open. 6. Faulty motor 	<ol style="list-style-type: none"> 1. Plug it into the power outlet. 2. Insert key and turn the switch ON. 3. Take to Sears Service Center for new cord. 4. Take to Sears Service Center for new plug. 5. Re-set; may be too many machines on line. 6. Take to Sears Service Center for repair or replacement.
Motor will not start and fuse or circuit breaker opens.	<ol style="list-style-type: none"> 1. Too many electrical machines. 2. Incorrect fuse. 3. Wheels do not rotate. 4. Undersized extension cord. 5. Short circuit. 	<ol style="list-style-type: none"> 1. Turn off other machines and try again. 2. Try time delay fuse, or go to circuit with higher rated fuse or circuit breaker. 3. Unplug and turn wheels by hand, move obstruction. 4. Use correct size extension cord; see page 5. 5. Cord, plug, or motor need repair; take to Sears Service Center for repair.
Motor fails to develop full power.	<ol style="list-style-type: none"> 1. Low line voltage. 2. Faulty motor or capacitor. 	<ol style="list-style-type: none"> 1. Check power line for proper voltage. 2. Take to Sears Service Center for evaluation.
Motor overheats.	<ol style="list-style-type: none"> 1. Overload on motor. 2. Poor ventilation of motor. Provide better air circulation. 3. Capacitor failure. 	<ol style="list-style-type: none"> 1. Reduce load to motor, feed work slower into blade. 2. Unplug and clean out around motor; provide better air circulation. 3. Take to Sears Service Center for repair.
Motor stalls or slows.	<ol style="list-style-type: none"> 1. Motor overload. 2. Low line voltage. 3. Loose wire connections. 4. Faulty motor. 	<ol style="list-style-type: none"> 1. Reduce load to motor, feed work slower into blade. 2. Check power line for proper voltage. 3. Take to Sears Service Center for repair. 4. Take to Sears Service Center for repair.
Frequent fuse or circuit breaker failure.	<ol style="list-style-type: none"> 1. Motor overload. 2. Overload of electrical circuit. 3. Incorrect fuse or circuit breaker. 	<ol style="list-style-type: none"> 1. Reduce load to motor, feed work slower into blade. 2. Too many electrical appliances on same circuit. 3. Have electrician upgrade service to outlet.

PARTS

CRAFTSMAN 12" BAND SAW

137.224320

WARNING

- When servicing use only CRAFTSMAN replacement parts. Use of any other parts may create a HAZARD or cause product damage.
- Any attempt to repair or replace electrical parts on this band saw may create a HAZARD unless repair is done by a qualified service technician. Repair service is available at your nearest Sears Service Center.

Order by PART NUMBER, not by key number

PARTS LIST FOR FIGURE A

Key	Part No.	Description	Size	Qty	Key	Part No.	Description	Size	Qty
1	3BS00101	BASE		1	41	3AE09601	SAFETY SWITCH		1
2	3BS00201	UPPER ARM		1	42	3AE04601	BALL BEARING	626ZZ	2
3	3BS00301	UPPER COVER, INNER		1	43	3BS04301	PLASTIC BRUSH ASSY.		1
4	3BS00401	COMPLETED MOTOR W/CORD		1	44	3BS04401	STEEL WASHER	3/8"*19	2
5	3BS00501	FRAME ARM COVER, UPPER		1	45	3AE01301	KEY	5*5*54	1
6	3BS00601	FRAME ARM COVER, LOWER		1	46	3BS04601	FLAT KEY	5*5*32.5	1
7	3BS00701	POST SEAT		1	47	3BS04701	KNOB		1
8	3BS00801	SLIDING BKT.		1	48	3BS04801	FLAT WASHER	3/8"*23	1
9	3BS00901	UPPER WHEEL SHAFT HINGE		1	49	3BS04901	HEX. SCREW	3/8"*1-1/2	1
10	3BS01001	SHAFT OF UPPER WHEEL		1	50	3BS05001	FLAT WASHER	3/8"*19	1
11	3BS01101	ADJUST KNOB ASSY.		1	51	3BS05101	HEX. SCREW	3/4"*2-1/2"	1
12	3BS01201	GUIDE POST(V TYPE)		1	52	3BS05201	FLAT WASHER	3/4"	2
13	3BS01301	GUIDE SUPPORT BRACKET BLADE GUARD		1	53	3BS05301	HEX. NUT	3/4:	1
14	3AE04501	BEARING SHAFT		2	54	3BS05401	NYLON NUT		1
15	3AE04701	Y TYPE BLOCK		2	55	3BS05501	TOOTH WASHER	5mm	2
16	3BS01601	ADJUST SPRING		1	56	3BS05601	COPPER WASHER		2
17	3BS01701	SQUARE NUT		1	57	3BS05701	SCREW(CROSS HEAD)/WASHER	3/16"*1/4"	2
18	3BS01801	STAR KNOB	5/16"*2"	1	58	3BS05801	STEEL WASHER	3/16-14	4
19	3BS01901	BUTTERFLY NUT	5/16"	1	59	3BS05901	STEEL WASHER	5/16"*23	2
20	3BS02001	PIN		2	60	3AE06201	LOWER SUPPORT BKT		1
21	3BS02101	SCREW(HEADLESS)	5/16"*5/16"	1	61	3BS06101	HEX. SCREW	1/4"*3/4"	2
22	3BS02201	SPRING		1	62	3BS06201	FLAT WASHER	1/4"*16	2
23	3BS02301	STEEL BALL	1/4"	1	63	3AE04801	STEEL PIN		4
24	3BS02401	STAR KNOB	5/16"*1-1/4"	1	64	3AE06901	SET SCREW(HEADLESS)	M6*16	1
25	3AE08701	POWER CORD STORAGE		2	65	3BS06501	SCREW(CROSS HEAD)/WASHER	3/16"*3/8"	13
26	3BS02601	BLADE GUARD, LOWER		1	66	3AE01201	CROSS HEAD SCREW	3/16"*3/8"	2
27	3BS02701	PLATE		2	67	3BS06701	HEADLESS CROSS SCREW	3/16"*3/8"	2
28	3AE08401	POWER CORD W/PLUG	SJT18*3C*2.3m	1	68	3BS06801	SET SCREW	1/4*1/4	5
29	3AE08501	POWER CORD W/INSERT PLUG	SJT18*3C*2FT	1	69	3AE04901	SET SCREW	1/4*1/2	4
30	3AE08601	STRAIN RELIEF BUSHING	6N-4	2	70	3BS07001	CROSS HEAD SCREW	3/16"*1/4"	2
31	3AE01101	BEARING COVER		1	71	3BS07101	SPRING WASHER	3/4"	1
32	3AE00501	C RING	S-15	1	72	3BS07201	MOTOR LABEL		1
33	3AE00401	BALL BEARING	620ZZ	2	73	3BS07301	LOWER GUIDE HOLDER ASSY.		1
34	3BS03401	PIN		2	74	3AE08801	CROSS HEAD SCREW W/ WASHER	3/16"*1/2"	2
35	3BS03501	FIXTURE BOLT		2	75	3BS07501	UPPER GUIDE HOLDER ASSY.		1
36	3AE06801	MOTOR PULLEY		1	76	3BS07601	SPRING WASHER	3/16"	2
37	3BS03701	SHAFT OF LOWER WHEEL		1	77	3BS07701	HEX. SCREW	5/16"*1-1/4"	4
38	3BS03801	HEX. FIXTURE BOLT		2	78	3BS07801	FLAT WASHER	5/16"*23"	8
39	3BS03901	CLIP HEAD		2	79	3BS07901	HEX. NUT	5/16"	4
40	3BS04001	GUARD	ABS	1					

FIGURE A

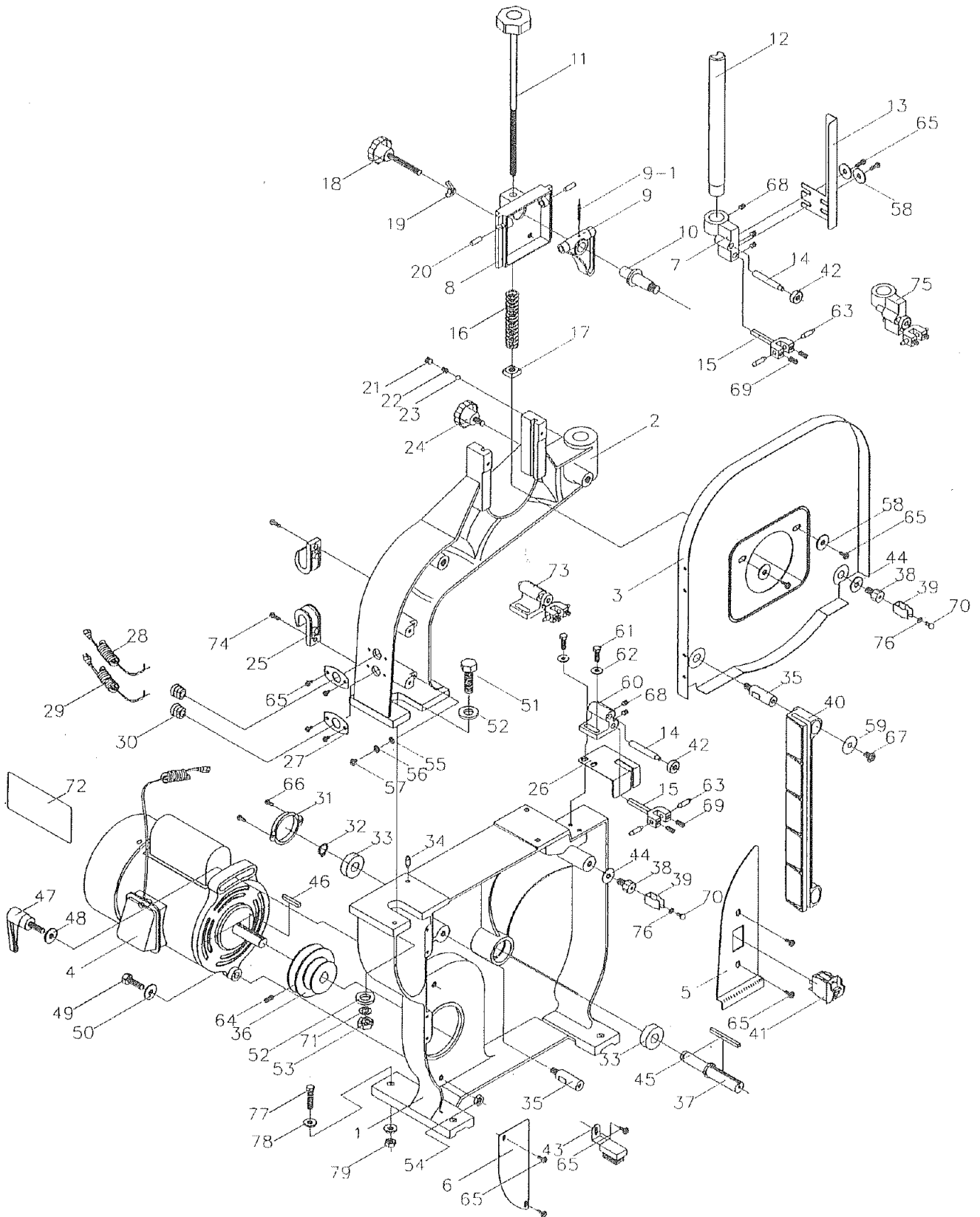

PARTS LIST FOR FIGURE B

Key	Part No.	Description	Size	Qty	Key	Part No.	Description	Size	Qty
80	3AE13101	DUST COLLECTION HOSE		1	110	3BS11001	CROSS HEAD SCREW W/ WASHER	3/16*3/8	4
81	3BS08101	KNOB		2	111	3BS11101	PULLEY	φ 180- φ 163	1
82	3BS08201	HINGE LOWER		1	112	3BS11201	LOWER DOOR		1
83	3AE01801	FLAT WASHER FOR LOWER WHEEL		1	113	3BS11301	UPPER DOOR		1
84	3BS08401	HINGE UPPER		1	114	3BS11401	UPPER WHEEL		1
85	3BS08501	CUTTING BLADE	80**3/8**0.5	1	115	3BS11501	LOWER WHEEL		1
86	3AE03401	BALL BEARING	6002ZZ	2	116	3BS11601	WHEEL PROTECTOR		2
87	3AE03501	HEX. NUT	1/2" THIN	1	117	3BS11701	NAMEPLATE		1
88	3AE12001	TRUNNION		2	118	3AE13801	WARNING LABEL		1
89	3AE11801	TRUNNION CLAMP SHOE		2	119	3BS11901	FLAT WASHER	1/4	2
90	3AE11901	HEX. SCREW	M10*50	2	120	3BS12001	HEX. SCREW	1/4*1/4	2
91	3AE03001	SPRING WASHER	5/16	6	121	3BS12101	UPPER WHEEL ASSEMBLY		2
92	3AE06501	HEX. SCREW	1/4**5/8"	6	122	3BS12201	CLAMP SHOE ASSEMBLY		1
93	3AE12101	SCALE	45 °	1	123	3AE13601	HEX. WRENCH	3mm	1
94	3AE10701	KNOB	10mm	2	124	3BS12401	INSTRUCTION MANUAL	#22432	1
95	3AE11301	HEX. SCREW	5/16**1-1/4"	2	125	3BS12501	PUSH/PULL LABEL		2
96	3AE11201	FLAT WASHER	5/16**18	2	126	3BS12601	V-BELT	A-26	1
97	3AE10901	POINTER		1	127	3BS12701	TRUNNION BRACKET		1
98	3AE08901	CROSS HEAD SCREW	3/16*3/8	1	128	3BS12801	SPRING CLIPPER		2
99	3AE11001	SPRING WASHER	3/16	17					
100	3BS10001	HEX. SCREW	5/16*1	1					
101	STD541031	HEX. NUT	5/16	1					
102	3BS10201	TABLE		1					
103	3AE12501	TABLE PIN		1					
104	3AE12401	SPRING PIN		1					
105	3AE12601	TABLE INSERT		1					
106	3BS10601	METER GAUGE ASSY.		1					
107	3BS10701	NUT	3/16	12					
108	3BS10801	CROSS HEAD SCREW W/ WASHER	3/16*1/4	12					
109	3AE13001	HEX. SCREW	1/4*5/8	1					



FIGURE B

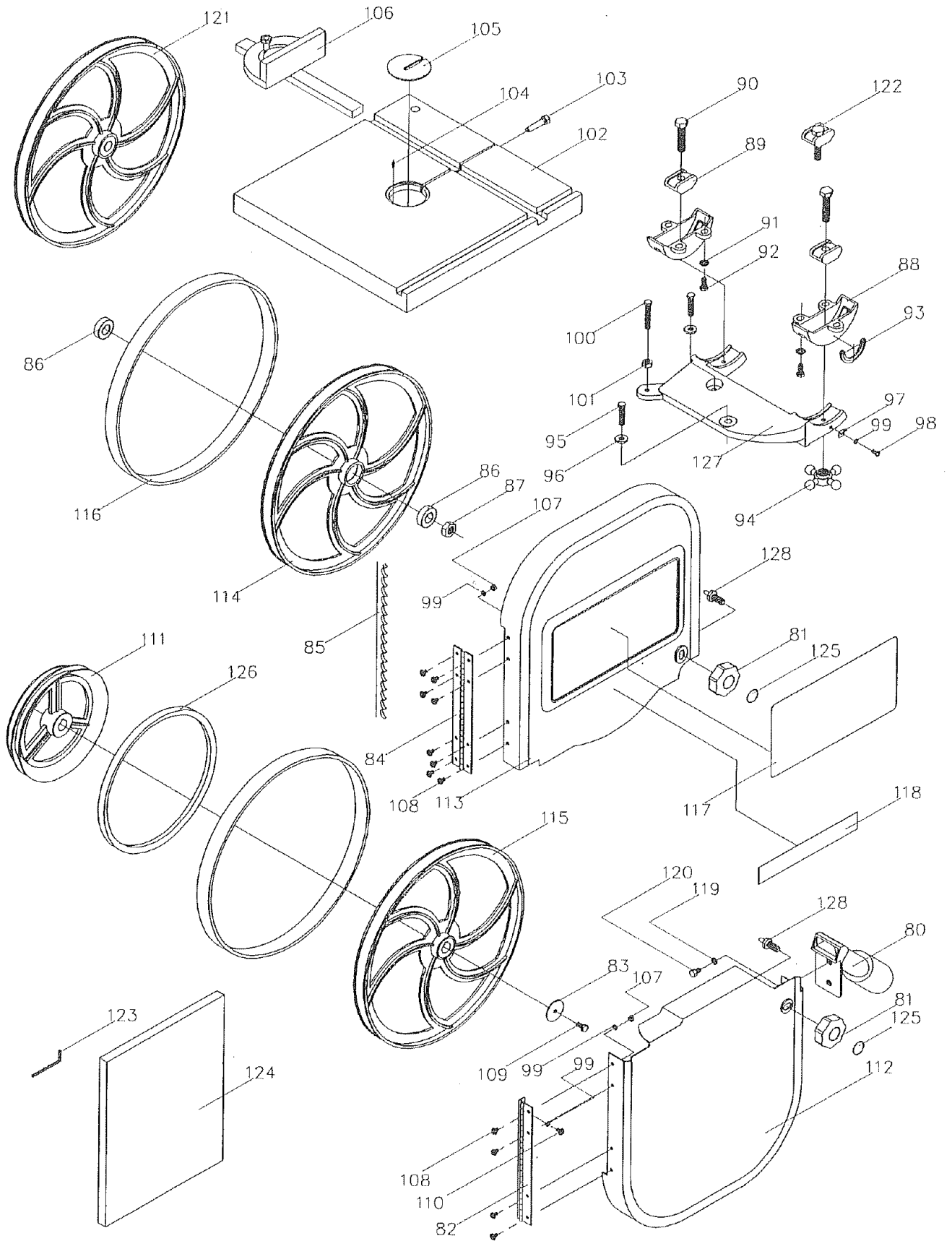

PARTS LIST FOR FIGURE C

Key	Part No.	Description	Qty
1	3BS40101	Stand top plate	1
2	3BS40201	Lower bracket (long)	2
3	3BS40301	Lower bracket (short)	2
4	3BS40401	Leg	4
5	3BS40501	Miter gauge storage	1
6	3BS40601	Screw	2
7	3BS40701	Nut	32
8	3BS40801	Flat washer	32
9	3BS40901	Screw	32
10	3BS41001	Pad	4

