

Copyright © 2025 by SHENZHEN SMARTSAFE TECH CO.,LTD. All rights reserved. No part of this publication may be reproduced, stored in a retrieval system, or transmitted in any form or by any means, electronic, mechanical, photocopying, recording or otherwise, without the prior written permission of SMARTSAFE.

Neither SMARTSAFE nor its affiliates shall be liable to the purchaser of this unit or third parties for damages, losses, costs, or expenses incurred by purchaser or third parties as a result of: Accident, misuse, or abuse of this unit, or unauthorized modifications, repairs, or alterations to this unit, or failure to strictly comply with SMARTSAFE operating and maintenance instructions. SMARTSAFE shall not be liable for any damages or problems arising from the use of any options or any consumable products other than those designated as Original SMARTSAFE Products or SMARTSAFE Approved Products by SMARTSAFE.

All information, specifications and illustrations in this manual are based on the latest information available at the time of printing. SMARTSAFE reserves the right to make changes at any time without prior written or oral notice.

### **Registered Trademark**

**SmartSafe** is a registered trademark of SHENZHEN SMARTSAFE TECH CO.,LTD. in China and other countries. All other SMARTSAFE trademarks, service marks, domain names, logos, and company names referred to in this manual are either trademarks, registered trademarks, service marks, domain names, logos, company names of SMARTSAFE or are otherwise the property of SMARTSAFE or its affiliates. In countries where any of the SMARTSAFE trademarks, service marks, domain names, logos and company names are not registered, SMARTSAFE claims other rights associated with unregistered trademarks, service marks, domain names, logos, and company names. Other products or company names referred to in this manual may be trademarks of their respective owners. You may not use any trademark, service mark, domain name, logo, or company name of SMARTSAFE or any third party without permission from the owner of the applicable trademark, service mark, domain name, logo, or company name. You may contact SMARTSAFE by visiting the website at [www.newsmartsafe.com](http://www.newsmartsafe.com), or writing to SHENZHEN SMARTSAFE TECH CO.,LTD., 3310, Building 11, Tianan Cloud Park, Bantian Street, Longgang District, Shenzhen, Guangdong, China, to request written permission to use Materials on this manual for purposes or for all other questions relating to this manual.

**Table of Contents**

**1. Safety Precautions ..... 1**

**2. Product Overview ..... 1**

    2.1. Equipment Interfaces and Controls ..... 1

    2.2. Accessories Introduction ..... 2

    2.3. Technical Characteristics ..... 3

**3. Product Usage ..... 4**

    3.1. Equipment Connection ..... 4

    3.2. Equipment Operation ..... 5

        3.2.1. Connect Detection Tablet ..... 5

        3.2.2. Compressor Test System ..... 9

    3.3. Guide ..... 15

    3.4. History ..... 15

    3.5. Settings ..... 17

        3.5.1 User Manual ..... 17

        3.5.2 Development and Maintenance ..... 17

        3.5.3 Factory Reset ..... 18

        3.5.4 About ..... 18



## 1. Safety Precautions

- (1) Follow the relevant requirements of the user manual to operate the equipment.
- (2) Take insulation measures when operating the equipment, and wear dry and clean insulating gloves.
- (3) Disconnect the operating power and test cables in case of equipment abnormality.

## 2. Product Overview

The ECP739 Electric Compressor Comprehensive Tester is a modular, multi-protocol compatible specialized test equipment developed by SmartSafe. It performs fast and accurate "off-vehicle" testing on compressors by simulating the real operating environment of the compressor on the vehicle (power supply, communication, load, etc.).

### 2.1. Equipment Interfaces and Controls

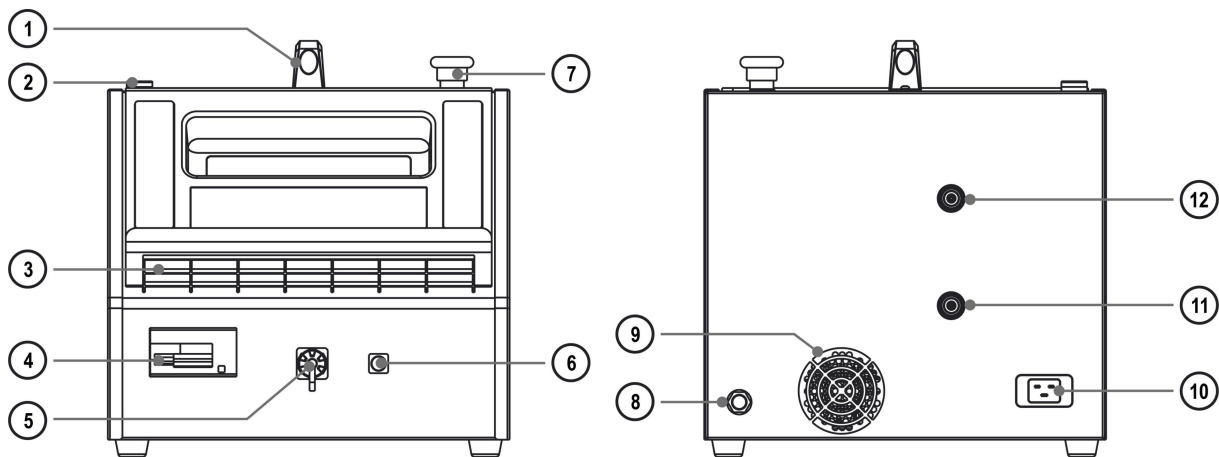









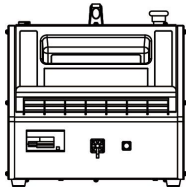

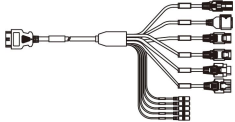

No.	Name	Description
1	Handle	Facilitates carrying the equipment.
2	Indicator Light	Solid blue indicates standby; solid green indicates working; flashing red indicates fault; solid red indicates stop warning.
3	Tablet Stand	Used to place the detection tablet.
4	AC Switch	Turns on/off the equipment AC input; circuit protection.
5	High Voltage Output Interface	Outputs high voltage electricity to simulate the vehicle system's power supply to the compressor.
6	Low Voltage Output Interface	Outputs low voltage electricity to simulate the vehicle system's power supply to the low-voltage components of the compressor.
7	Emergency Stop Switch	Used to cut off power to the equipment in an emergency and immediately stop operation. After pressing this emergency stop button, rotate the switch to the right to reset it before the AC switch can be closed again.
8	Vent	Used to vent gas from the tank.

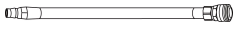
9	Cooling Fan	Dissipates internal heat when the equipment is working.
10	Power Input Port	Used to connect to the power source.
11	Oil Drain Port	Drains residual refrigerant oil from inside the equipment.
12	High-Pressure Port	Connects to the high-pressure piping of the electric compressor under test for compression performance and line leak-tightness testing.

## 2.2. Accessories Introduction

The following accessories are for reference only. For product configuration details, please consult your local dealer or refer to the packing list supplied with the device.

No.	Name	Qty	Unit	Reference Image
1	Main Unit	1	PCE	
2	AC Power Cord	1	PCE	
3	High Voltage Wiring	1	PCE	
4	External Low-Voltage Plug	1	PCE	
5	Compressor Testing Cable	1	PCE	
6	High Voltage Jumper 1	1	PCE	 Black Red
7	High Voltage Jumper 2	1	PCE	 Black Red
8	Compressor Takeover Kit	1	PCE	
9	Compressor Oil Discharge Pipe Kit	1	PCE	
10	Plug Kit	1	SET	-
11	Password Envelope	1	PCE	
12	Quick Reference Guide	1	PCE	
13	User Manual	1	PCE	
14	Packing List	1	PCE	

### 2.3. Technical Characteristics

Parameter Name	Description
<b>Model</b>	ECP739
<b>Power Supply</b>	AC 100-240 V, 50/60 Hz, 16 A Max
<b>Power Input</b>	3.5KW TYP
<b>High Voltage Output</b>	DC 50-750 V, 20 A Max
<b>Low Voltage Output</b>	DC 12 V/24 V, 2 A Max
<b>Gas Tank Capacity</b>	3 L
<b>Equipment Air Pressure</b>	12 kgf/cm <sup>2</sup> Max
<b>Compressor Drive Method</b>	CAN, LIN, Enable Control
<b>Protection Function</b>	AC Protection: 0-40 A adjustable circuit breaker; DC Protection: manual circuit breaker
<b>Operating Temperature</b>	-10 °C~50 °C
<b>Storage Temperature</b>	-20 °C~70 °C
<b>Operating Humidity</b>	20%~90%
<b>Storage Humidity</b>	10%~90%
<b>Dimensions</b>	385.3 x 543.5 x 388.0 mm

## 3. Product Usage

### 3.1. Equipment Connection

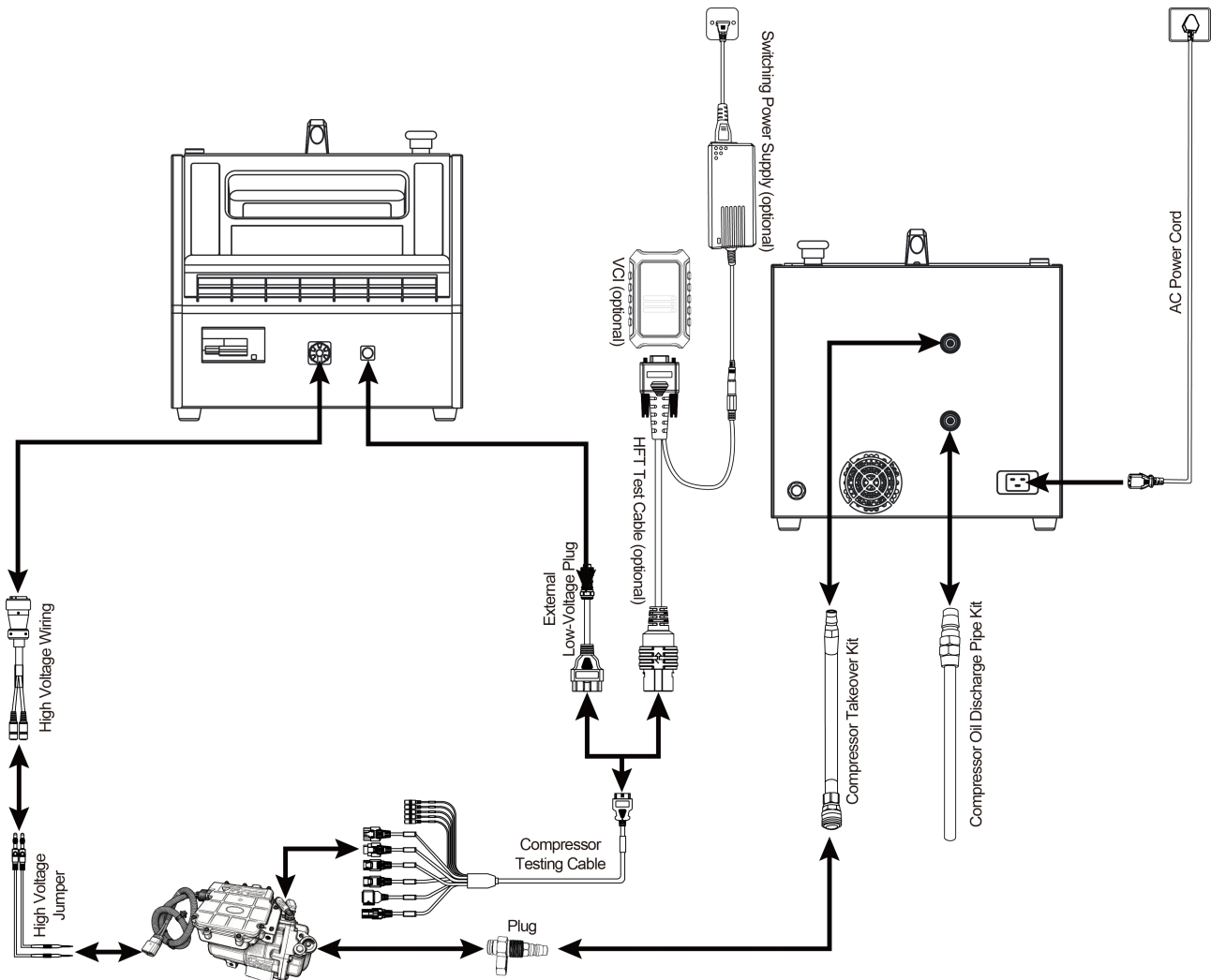

#### High Voltage Connection

Insert one end of the aviation plug of the high voltage docking cable into the equipment's "**High Voltage Output Interface**", and connect the other end to the positive and negative terminals of the compressor high voltage socket using high voltage jumpers.

#### Low Voltage Connection

- Connect the external low voltage plug to the equipment's "**Low Voltage Output Interface**". Connect the other end to the female connector of the compressor test cable. Select the corresponding interface according to the compressor type to insert into the low voltage communication interface of the compressor. If a matching interface has not been developed for the compressor, use jumpers for connection according to the software guidelines.
- To detect compressor faults, it is necessary to use a compressor testing cable to connect the VCI Box (optional) with the compressor's low-pressure communication interface for testing.

#### High-Pressure Port

Connect the compressor piping assembly to the equipment's "**High-Pressure Port**", and connect the other end to the compressor's high-pressure pipe port via the plug.

#### Oil Drain Port

Connect the compressor oil drain pipe assembly to the equipment's **"Oil Drain Port"**, and connect the other end to a recovery container.

### Power Supply Connection

Use the supplied power cable to connect the equipment's power input port and the power socket to supply power to the equipment. Confirm that the input voltage matches.

## 3.2. Equipment Operation

The ECP739 needs to be operated with a detection tablet (optional) loaded with the **"Compressor"** APP.

### 3.2.1. Connect Detection Tablet

- (1) Tap the **"Compressor"** icon on the home page of the detection tablet to launch the corresponding APP.

Note: Functional modules may vary across different detection tablets. The following images are for reference only. Please refer to the actual detection tablet for specific functional modules.

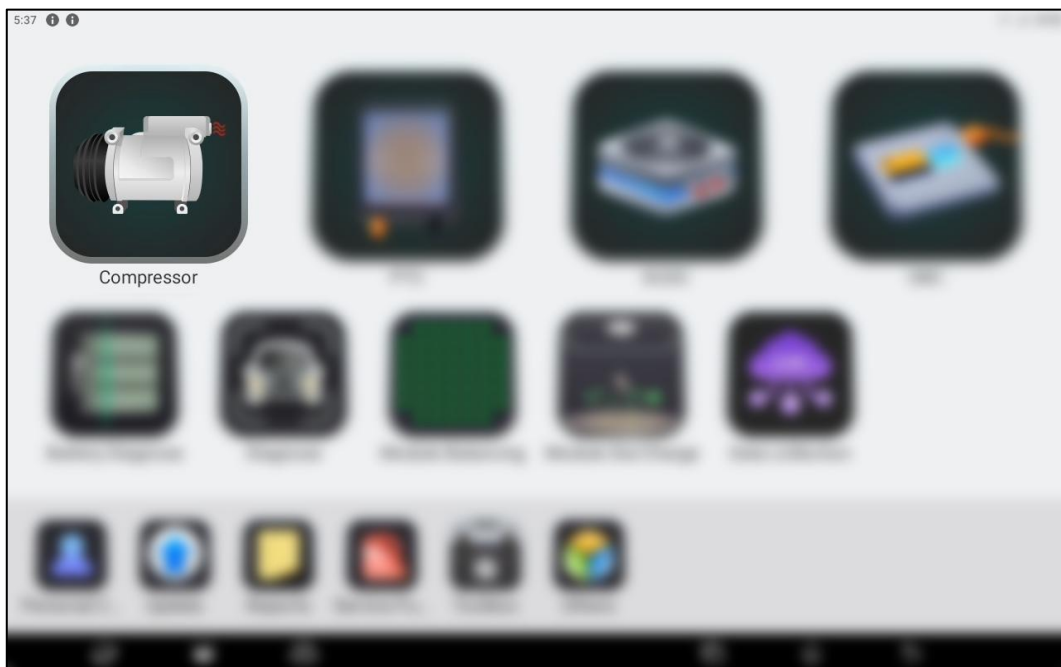

- (2) Select the **"Compressor Test System"** option in the pop-up window.

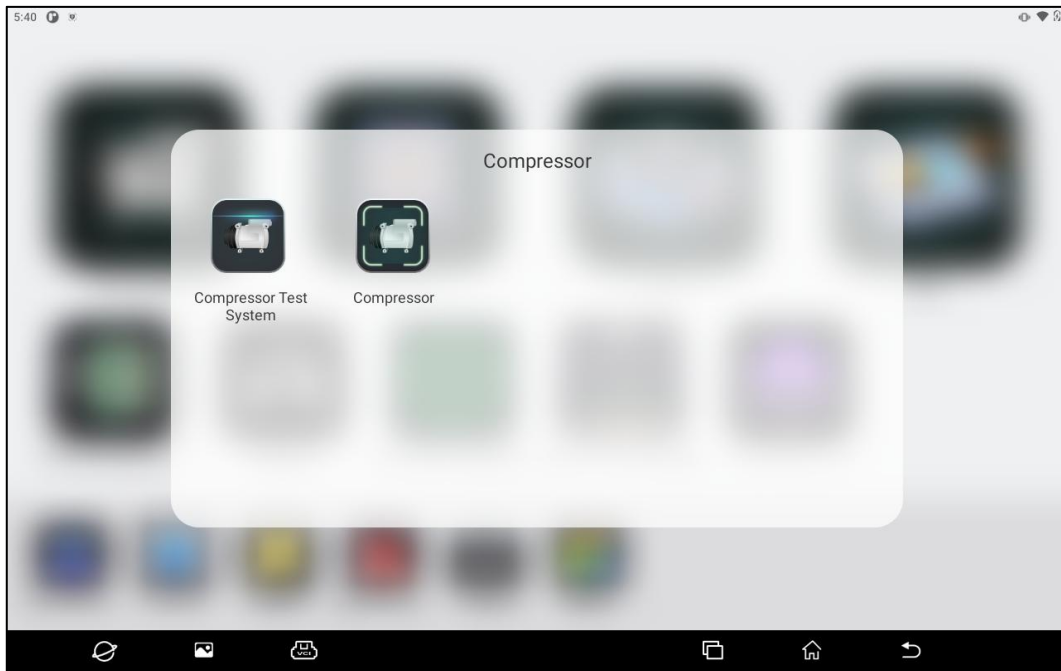

(3) If the detection tablet has previously connected to an ECP739 device, the APP will enter the device display interface upon startup and show the devices the tablet has connected to.

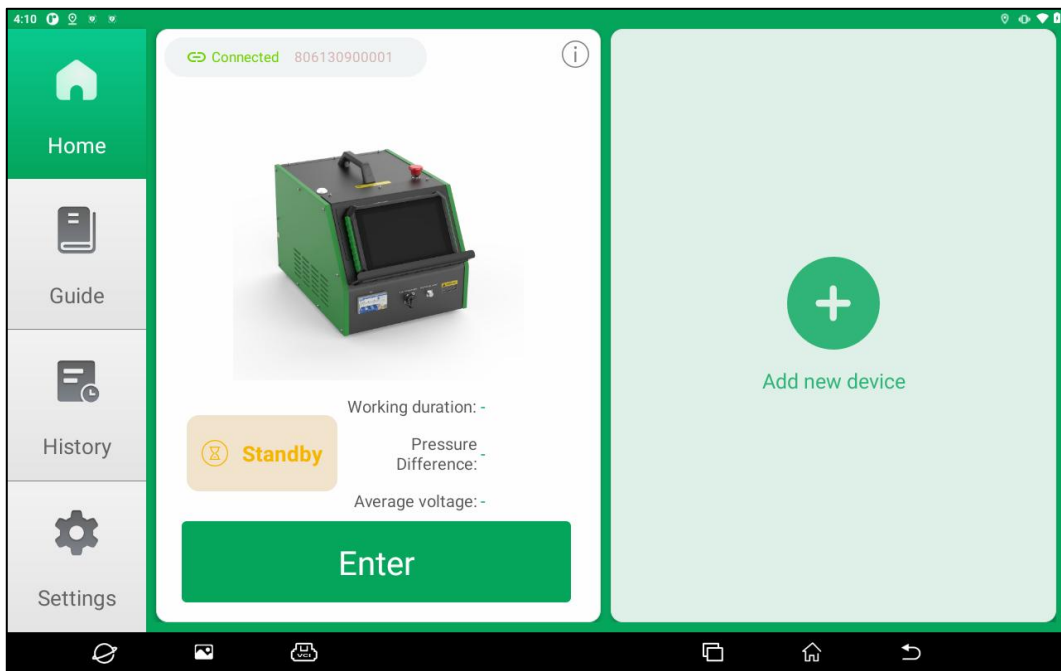

If the detection tablet has not connected to an ECP739 device before, the APP will enter the device search page upon startup. Follow the on-screen prompts to connect the power supply of the ECP739 device and turn on its DC and AC switches. Wait for the indicator lights on the top of the device to flash alternately in red and green.

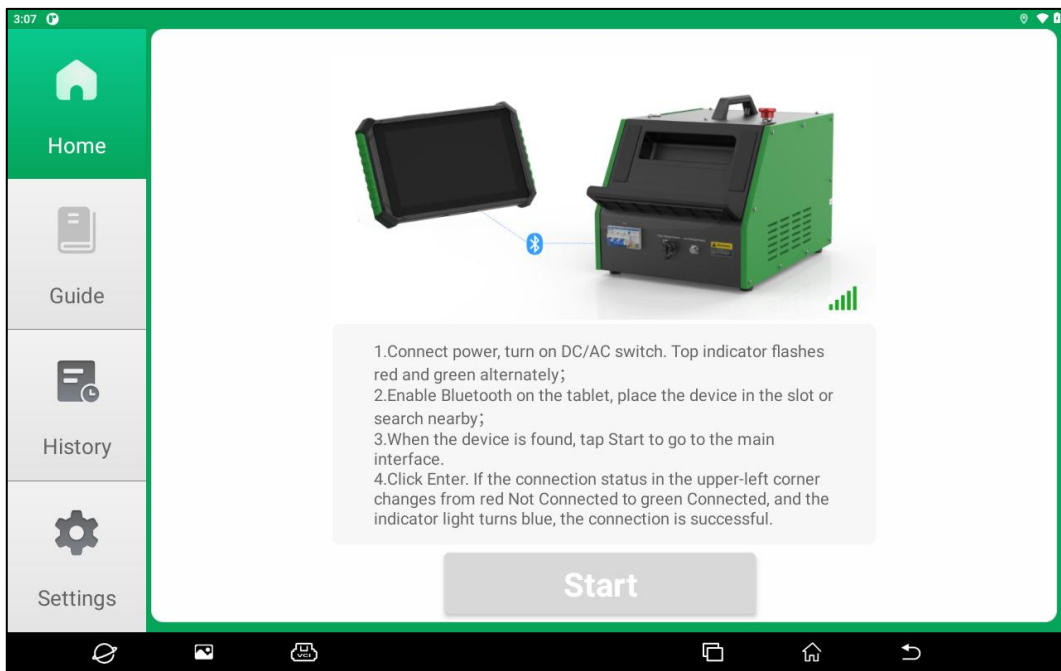

- (4) Enable the Bluetooth function of the detection tablet, and keep the distance between the tablet and the ECP739 device within 1 m.
- (5) After the ECP739 device is found, the page displays "Device Found", and the **"Start"** button turns from gray to green. Tap the **"Start"** button to enter the home page.

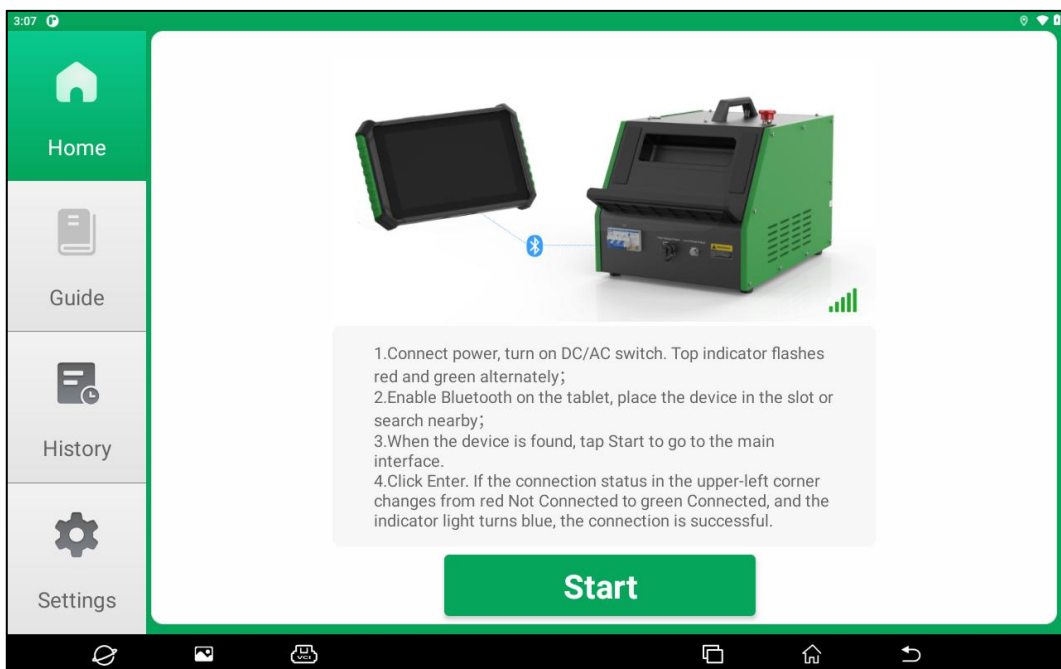

- (6) Confirm that the ECP739 device serial number matches the one displayed on the interface, then tap the **"Enter"** button.

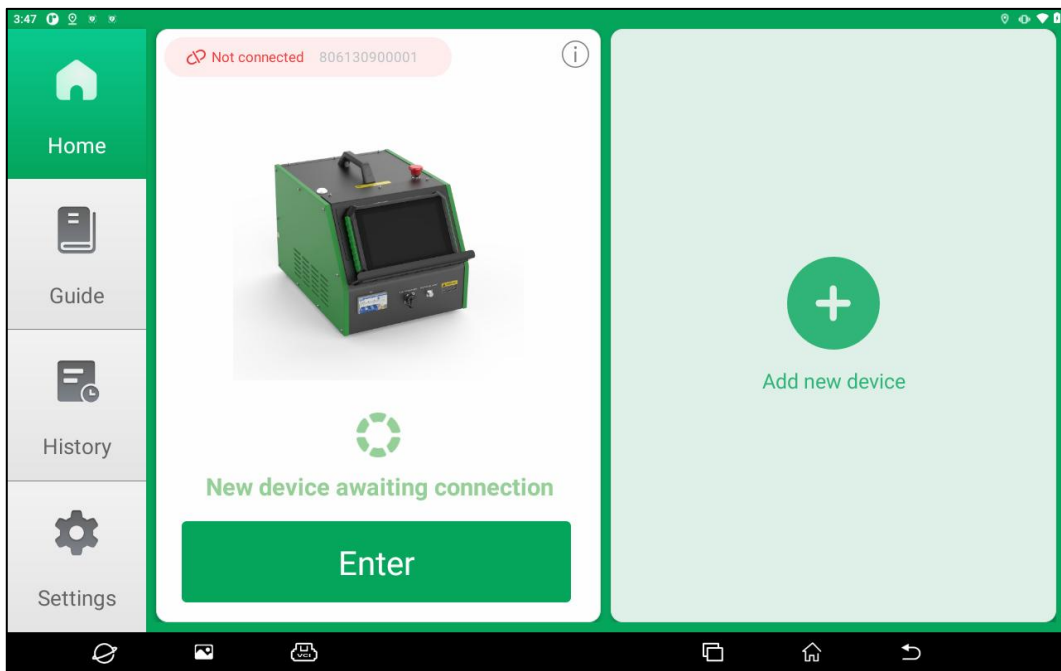

- (7) When the connection status in front of the device serial number on the screen displays "Connected", it means the connection is successful. Tap the **"Add New Device"** button to add a new device in the same way.

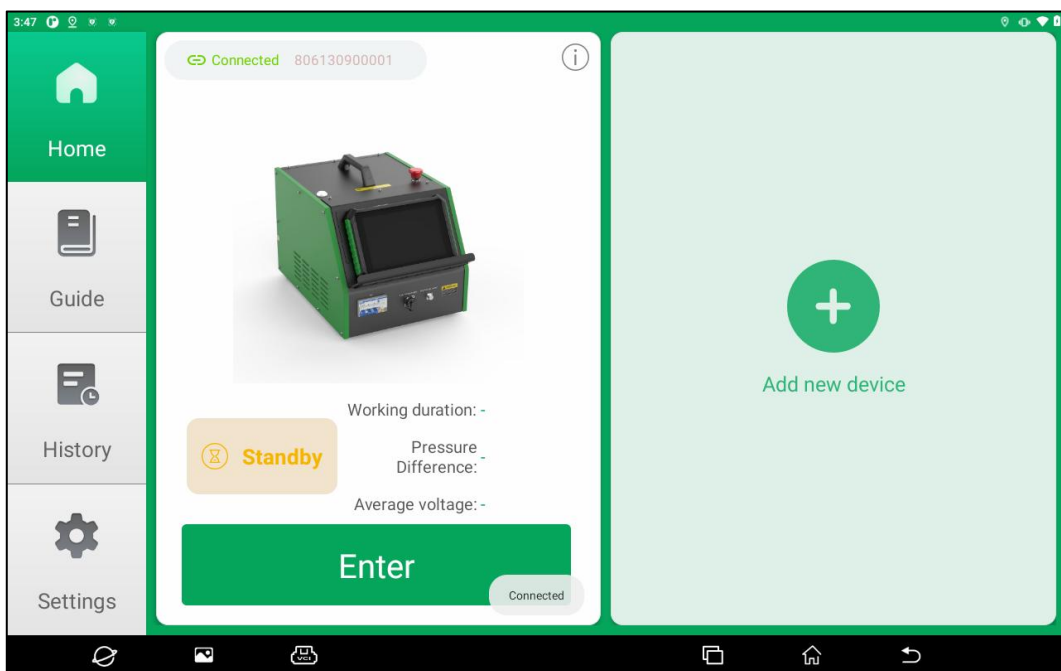

Note: The detection tablet can connect and bind up to two ECP739 devices simultaneously. If you want to connect a new device after connecting two devices, you must remove a previously connected device.

- (8) Tap the icon in the upper-right corner of the single-device display interface. ⓘ button to enter the device details page, where you can view device information and remove the device.

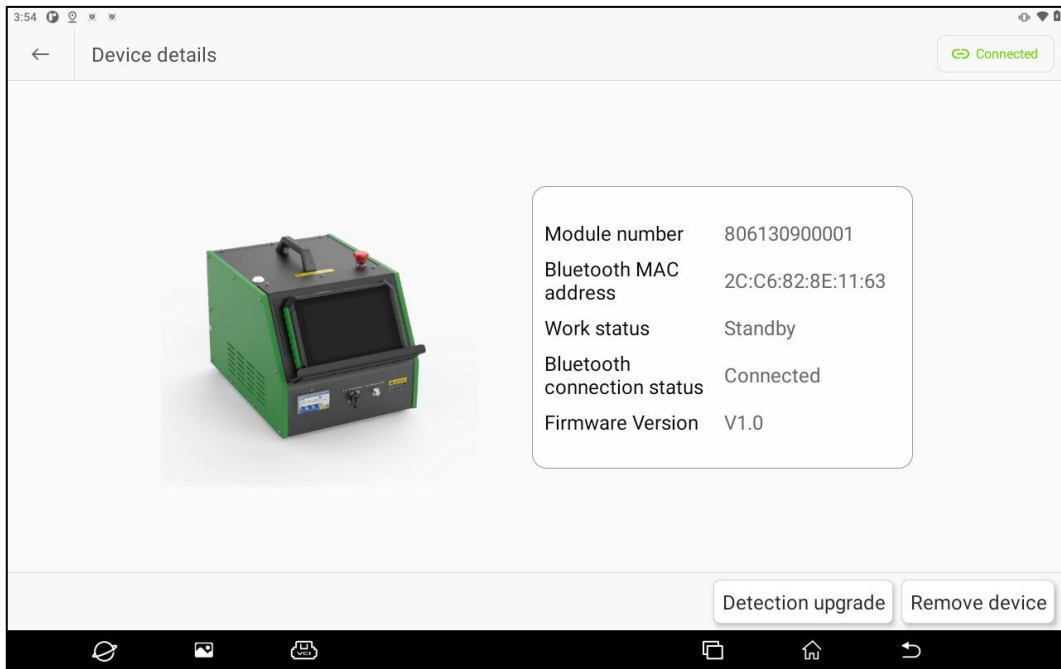

- (9) Tap the **"Remove Device"** button, and then tap **"Confirm"** to unbind the device from the detection tablet.

### 3.2.2. Compressor Test System

- (1) Tap the **"Compressor"** icon on the detection tablet, then select the **"Compressor Test System"** option in the pop-up window to enter the compressor test system home page.

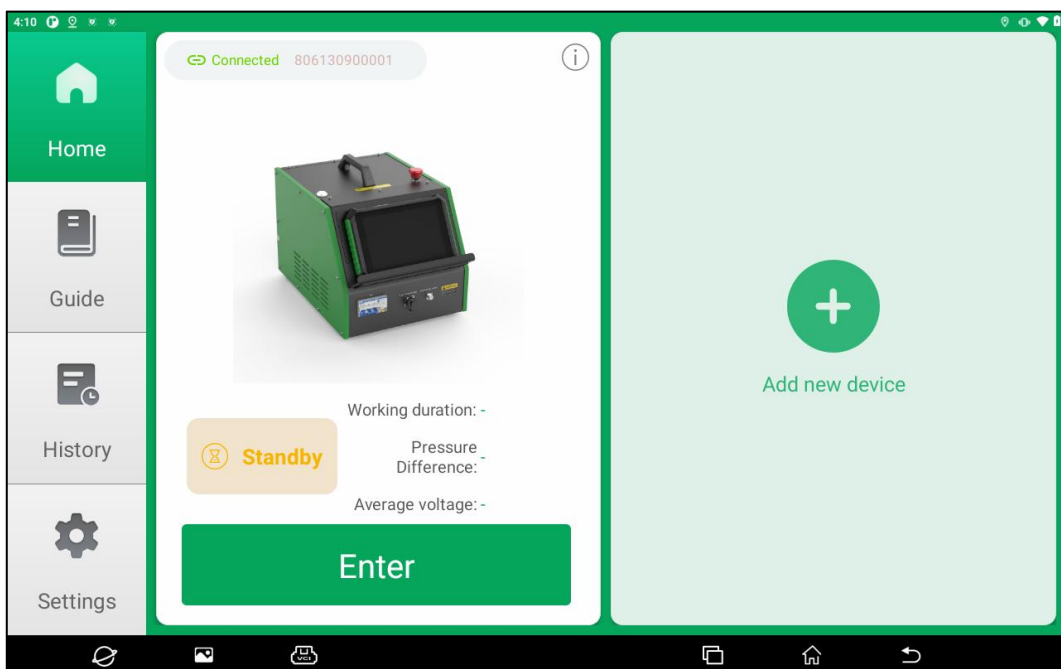

- (2) Tap the **"Enter"** button on the device card to enter the compressor model selection page. Select the corresponding vehicle brand, compressor brand, or compressor model to proceed to the next step. After learning and understanding the relevant safety regulations for operating the equipment, tap **"Next"**. The equipment will start testing the compressor.

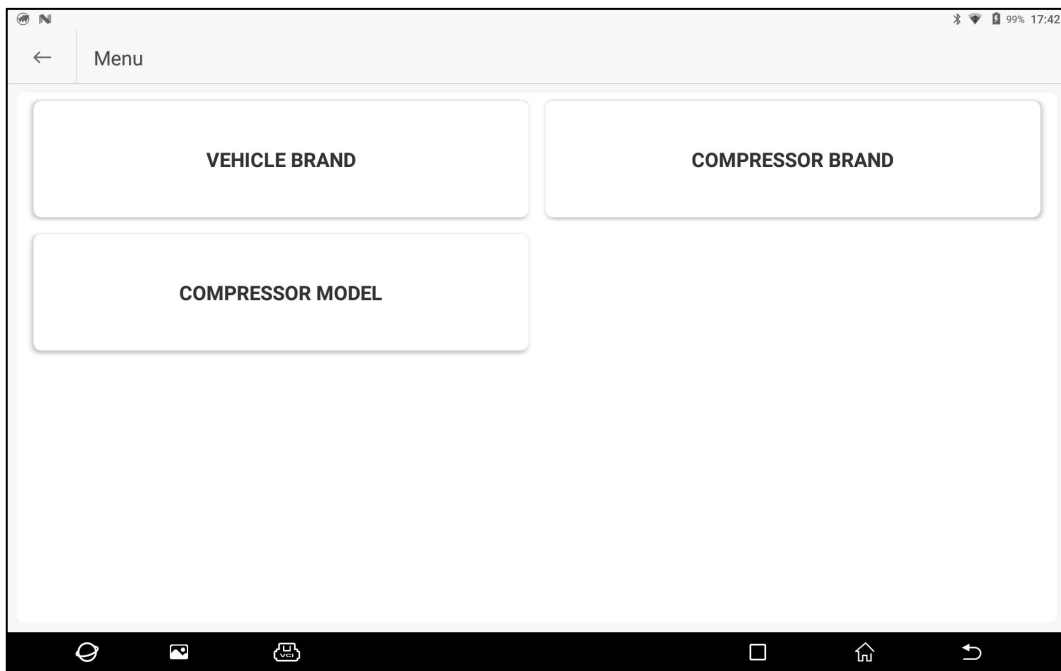

- (3) After learning and understanding the relevant safety regulations for operating the equipment, tap **Confirm** and the device will begin detecting the compressor.

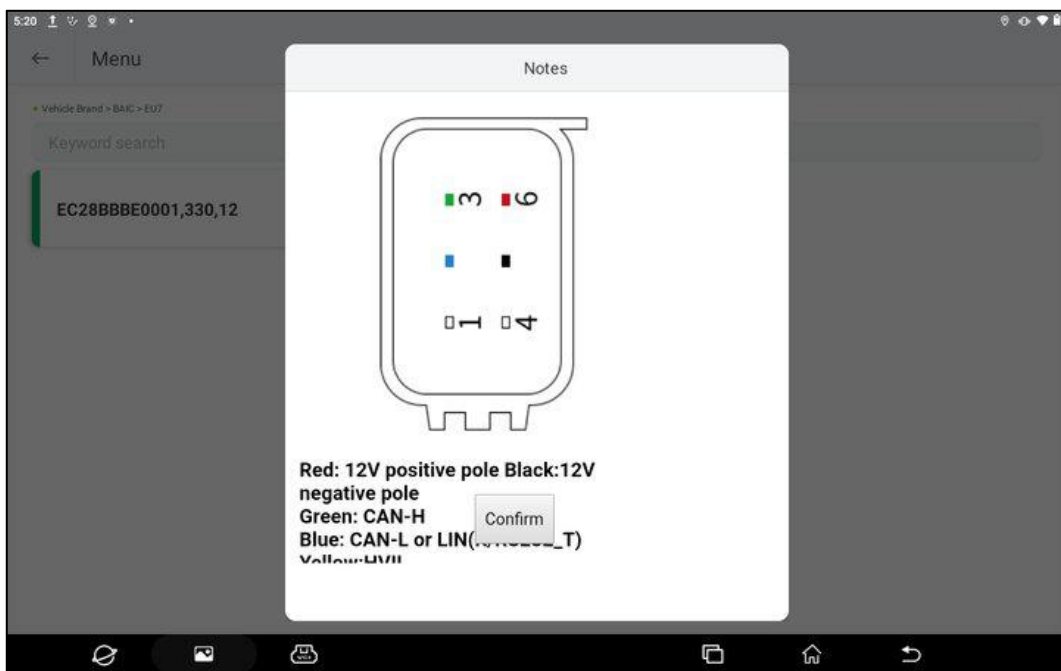

- (4) Parameters and curves related to the equipment's operating status can be viewed on the test working page.

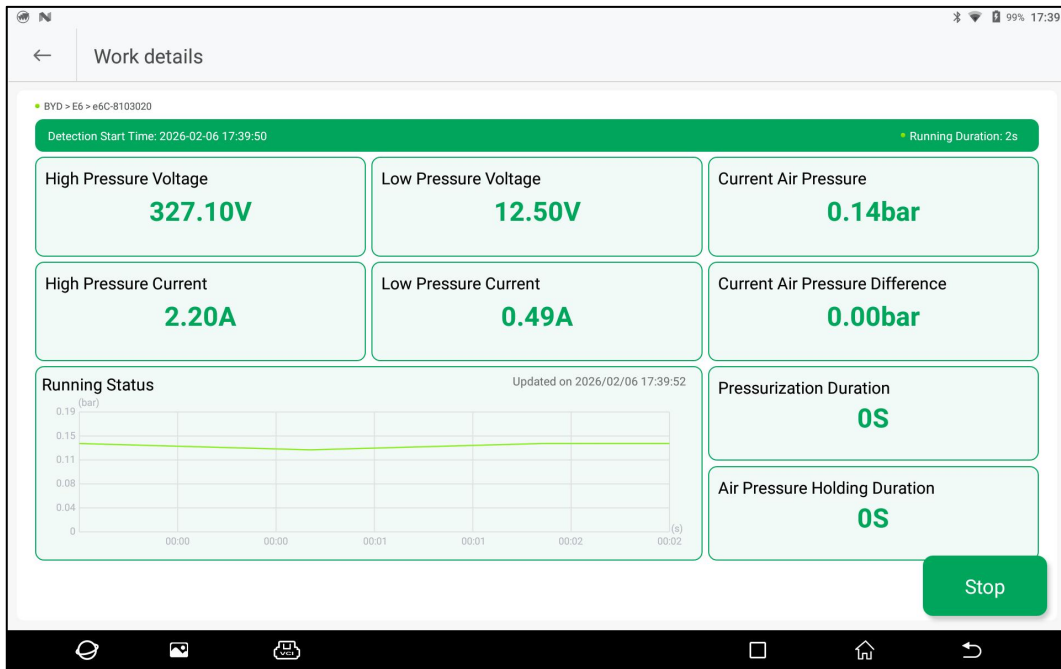

Parameter Description	
<b>HV Voltage</b>	The high voltage driving the compressor motor.
<b>High Voltage Current</b>	The operating current driving the compressor motor.
<b>LV Voltage</b>	The low voltage of the compressor control circuit.
<b>Low Voltage Current</b>	The operating current of the compressor control circuit.
<b>Current Pressure</b>	The refrigerant pressure inside the compressor or in the pipeline.
<b>Current Pressure Difference</b>	The difference between the pressure at the beginning and end of the pressure holding process.
<b>Running Duration</b>	The duration of the compressor test.
<b>Pressurization Duration</b>	The time taken for the compressor to rise to the current pressure value.
<b>Pressure Holding Duration</b>	The time during which the compressor maintains stable pressure in the pressure holding stage after reaching the target pressure.
<b>Running Status Curve</b>	Displays the dynamic trend of pressure changes over time during the test.

(5) Tap the **"Stop"** button to end the current test process. After stopping, tap **"View Report"** to generate the test report.



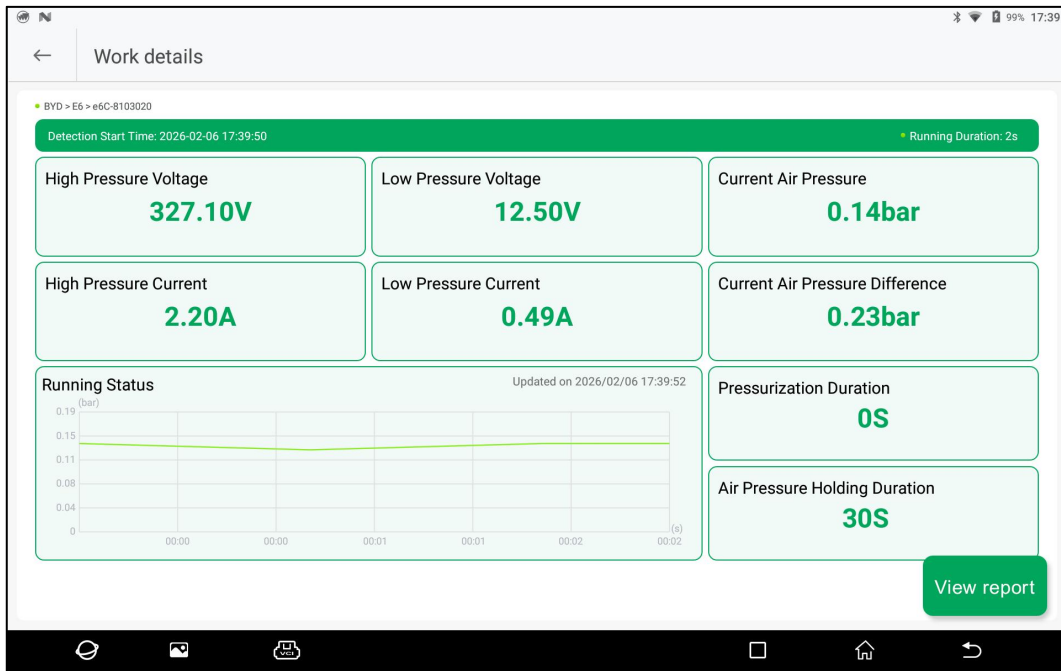

Tap "Share" to share the test report via QR code, email, or Bluetooth.

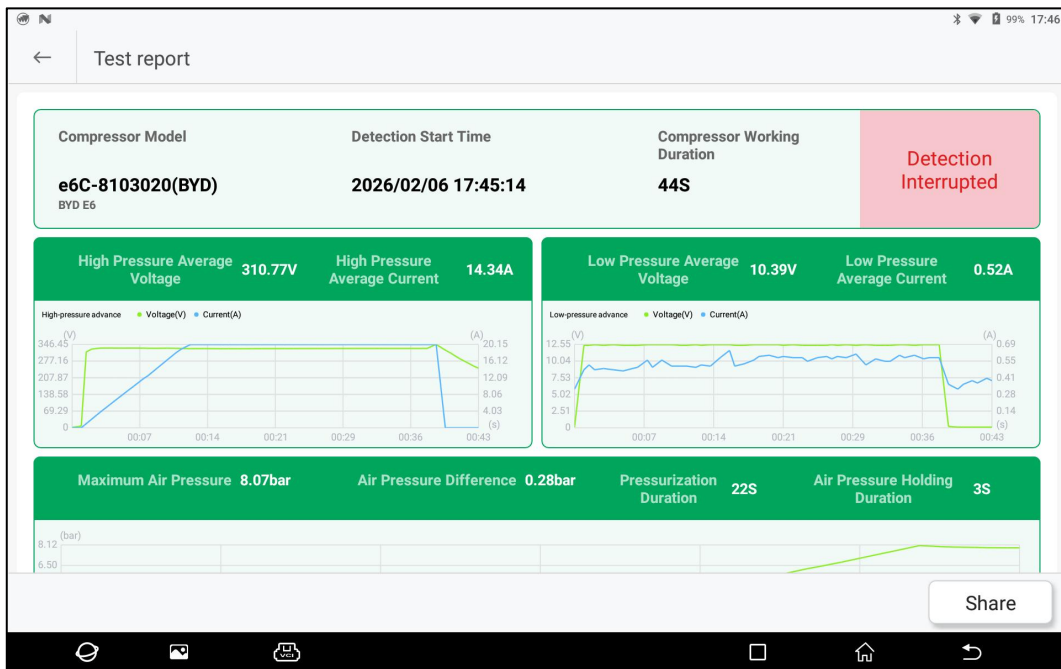

(6) If a fault is detected in the compressor, the job details page after the detection will be displayed as follows. Tap the **View Repair Instructions** button on this page.



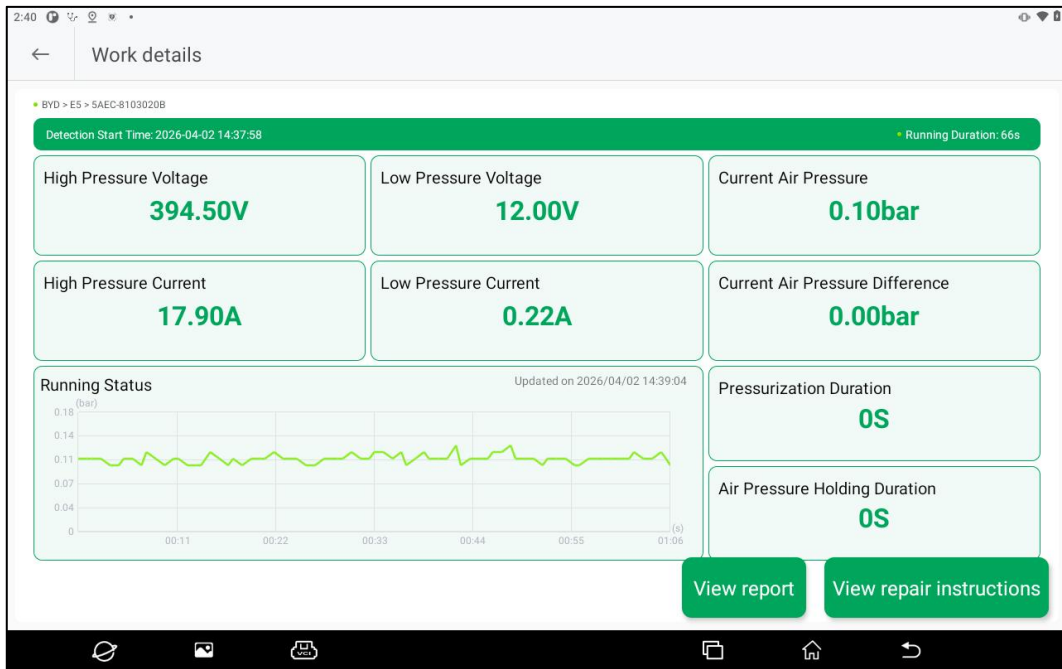

Then, on the following page, tap **ECU Detection** button.

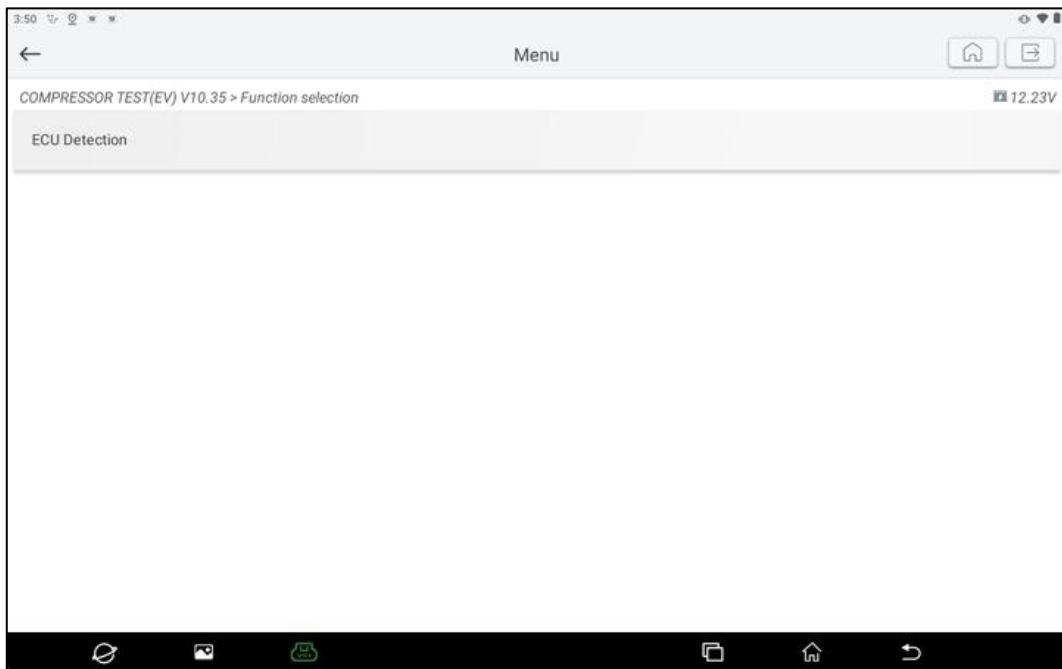

If a fault code is read, the system will enter the fault code display page as shown below. On this page, tap **Help** button corresponding to the fault code to view the related repair instructions.



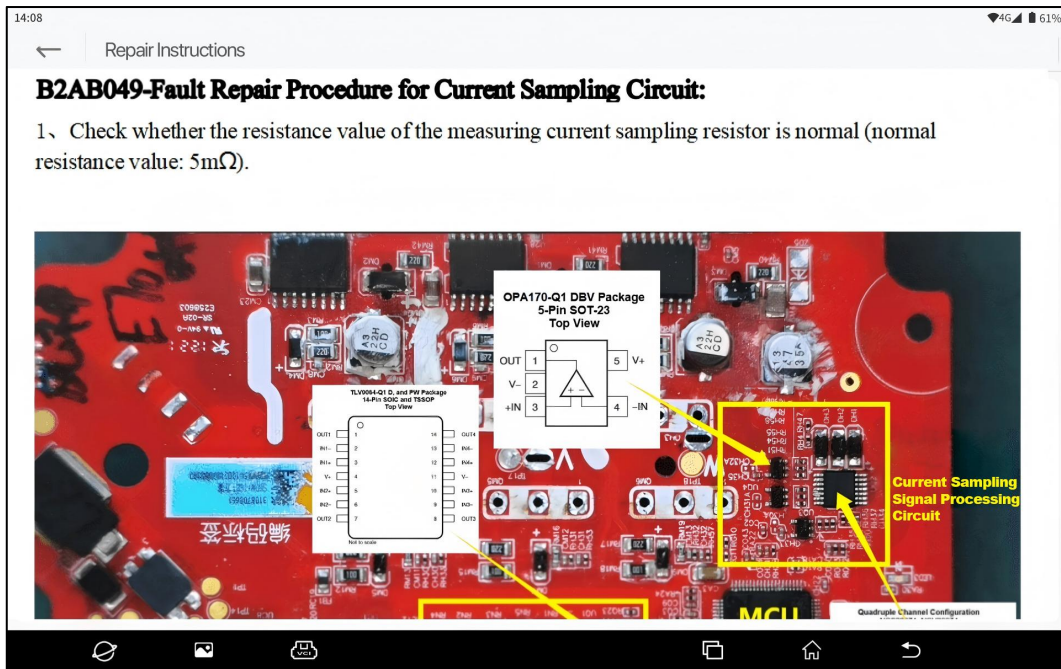
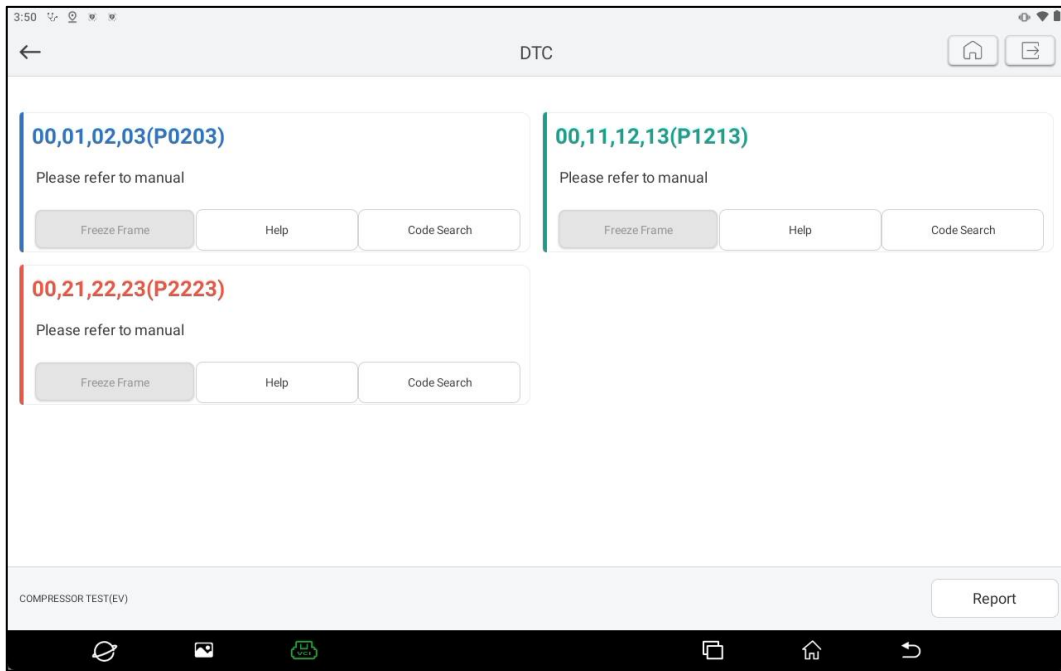

If no fault code is read, the current status of the fault diagnosis will be displayed as “No DTC”.

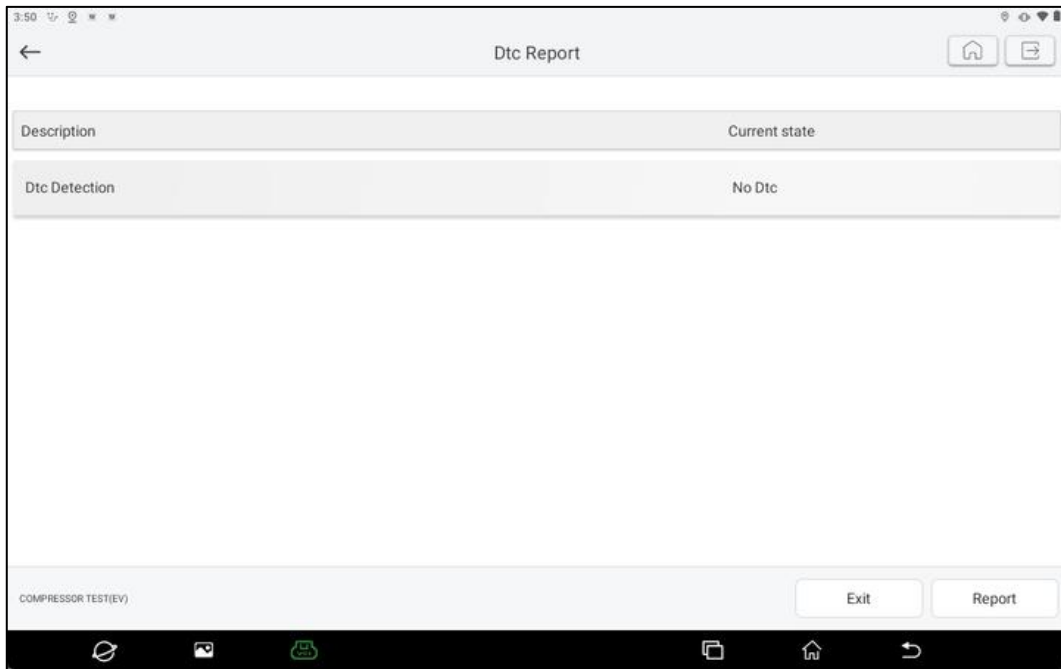

### 3.3. Guide

Tap **"Guide"** in the left function module navigation on the compressor test system main interface to view the quick Guide of the equipment.

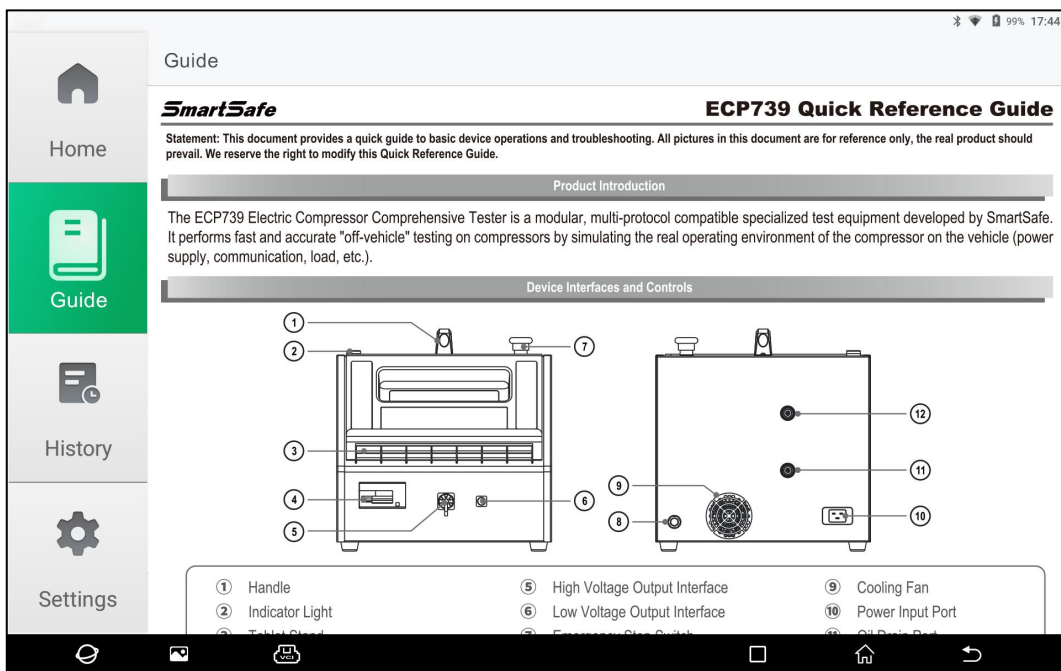

### 3.4. History

(1) Tap **"History"** in the left function module navigation on the compressor test system main interface to enter the history interface.



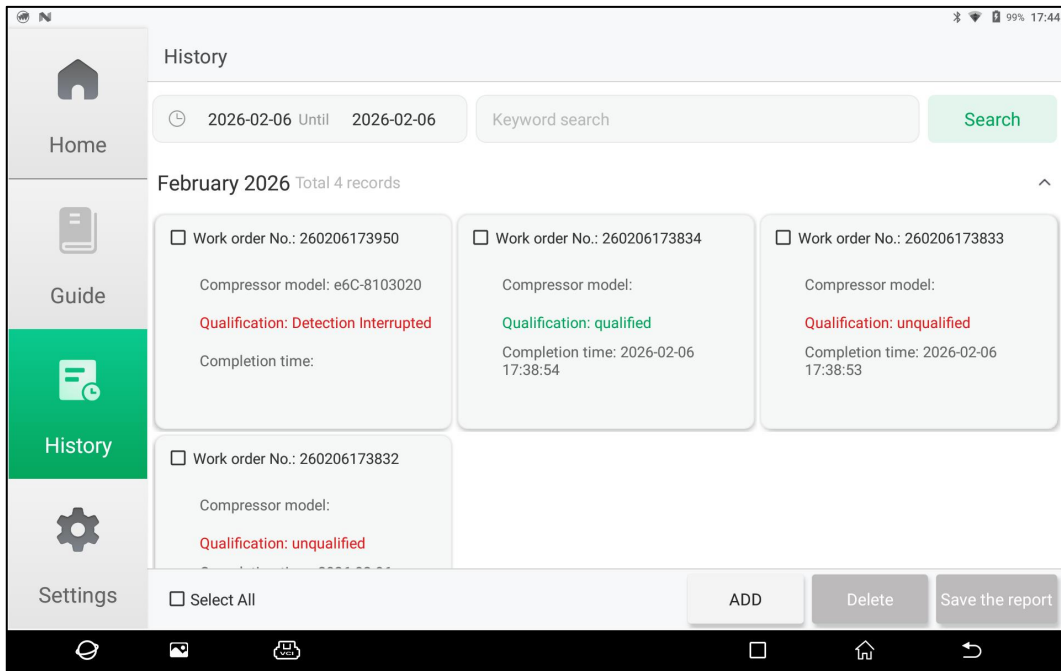

- (2) Check one or multiple history records, and tap **"Delete"** to delete the checked records.
- (3) Set the start and end dates or enter keywords, then tap **"Search"** to filter out records that meet the criteria.
- (4) Tap a single record card to view the detailed test report for that record.

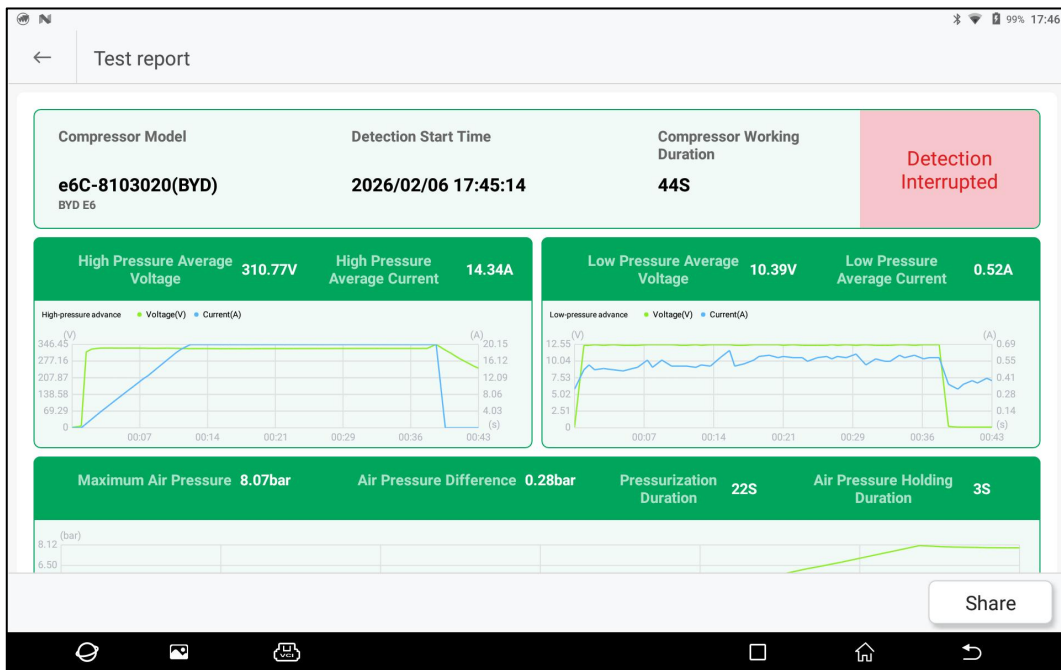

- (5) Tap **"Share"** on the test report page to share the test report via QR code, email, or Bluetooth.

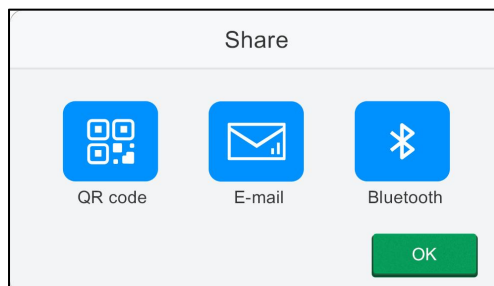

### 3.5. Settings

Click on the **"Compressor"** icon on the detection tablet, then select the **"Compressor Test System"** option in the pop-up window to enter the compressor test system homepage, and then tap **"Settings"** in the left functional module navigation to enter the settings interface. The settings options include User Manual, Development Maintenance, and About.

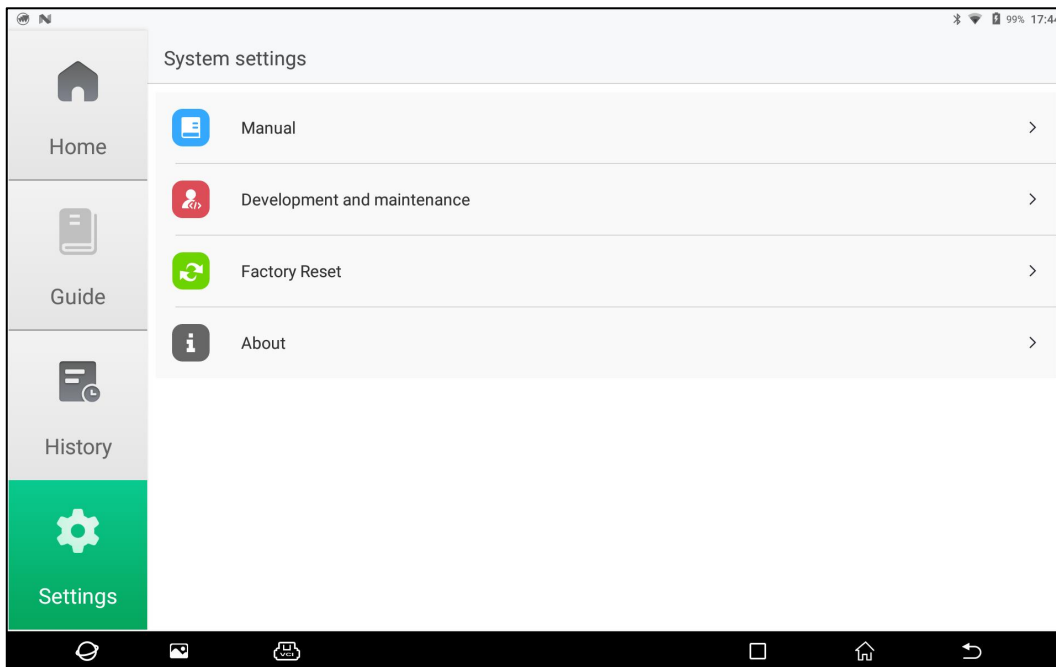

#### 3.5.1 User Manual

Tap **"User Manual"** on the settings interface to enter the manual interface, where you can view the user manual online.

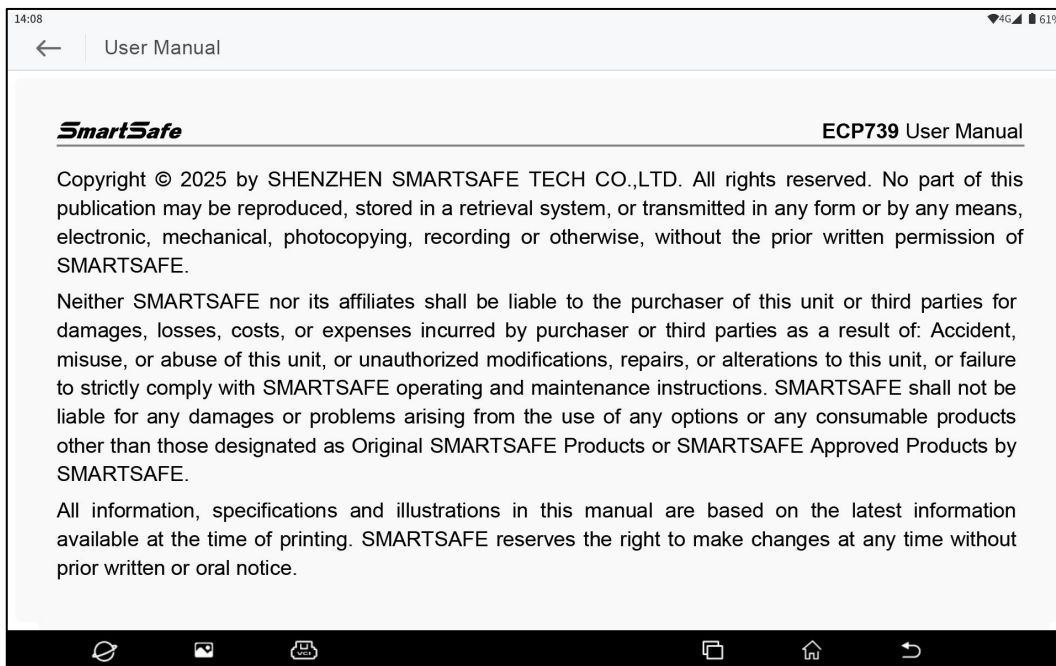

#### 3.5.2 Development and Maintenance

Tap **"Development and Maintenance"** on the settings interface to enter the development and maintenance interface. This function is for manufacturer testing only and requires a dedicated password to access. Unauthorized personnel are not allowed to access it.



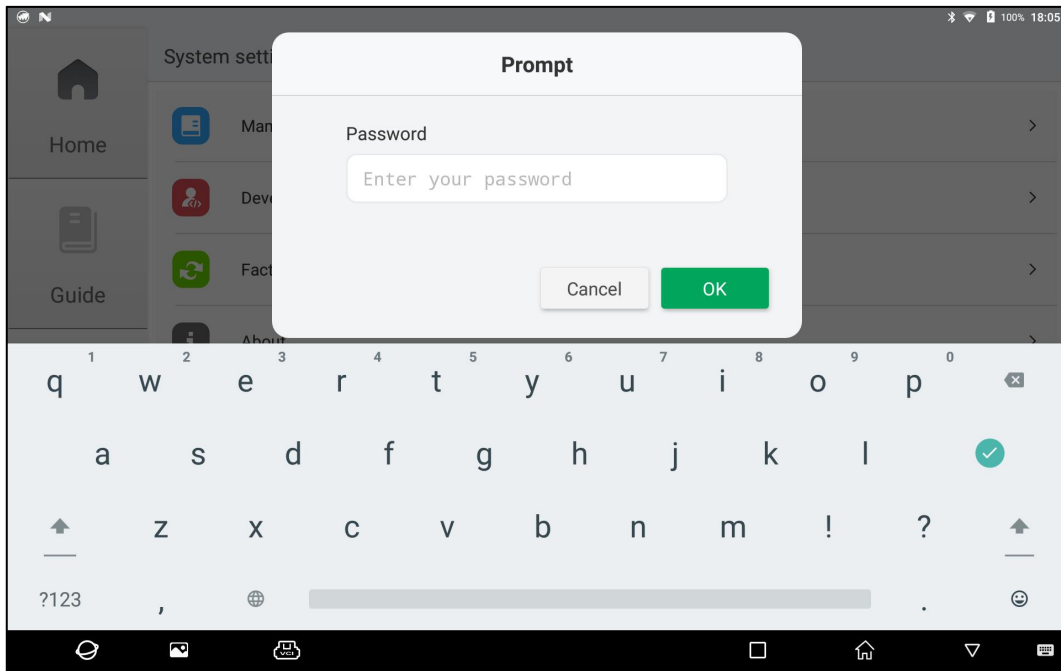

### 3.5.3 Factory Reset

This operation will delete personal data and custom settings. Please proceed with caution.

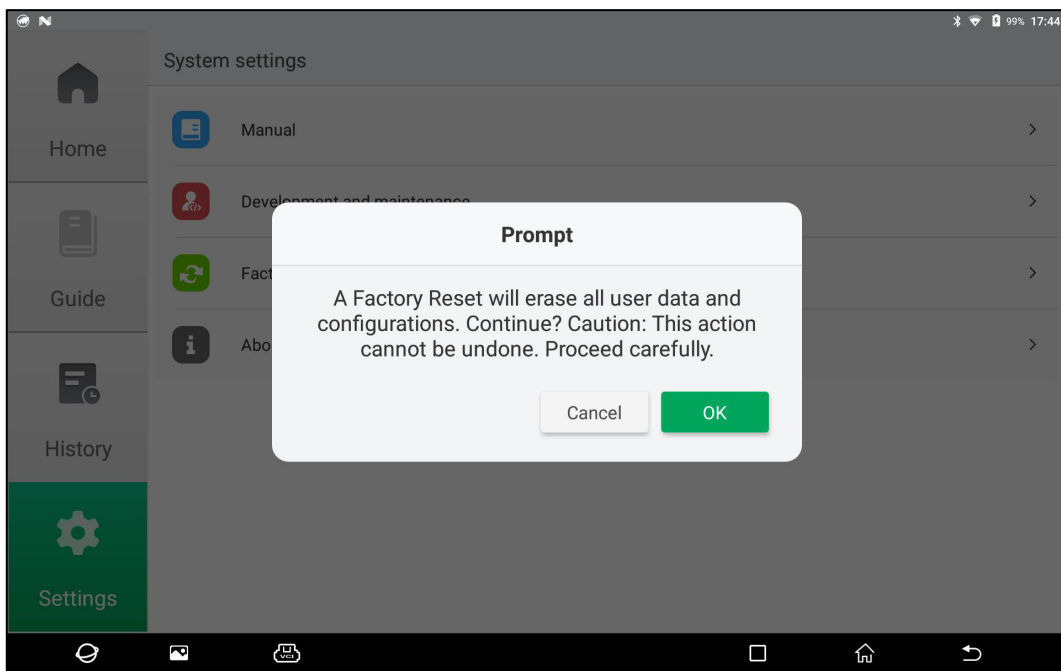

### 3.5.4 About

Tap "**About**" on the settings interface to enter the following interface, where you can view APP version information and check for APP updates.

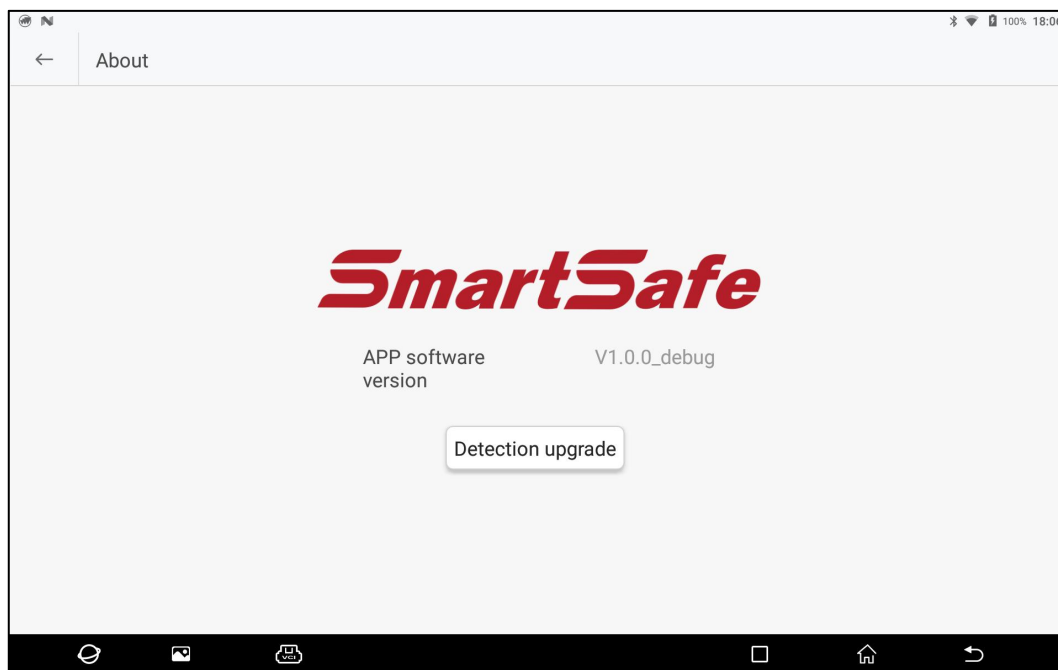
**FCC Caution:**

This device complies with part 15 of the FCC Rules. Operation is subject to the following two conditions: (1) this device may not cause harmful interference, and (2) this device must accept any interference received, including interference that may cause undesired operation.

Any changes or modifications not expressly approved by the party responsible for compliance could void the user's authority to operate the equipment.

NOTE: This equipment has been tested and found to comply with the limits for a Class B digital device, pursuant to Part 15 of the FCC Rules. These limits are designed to provide reasonable protection against harmful interference in a residential installation. This equipment generates, uses and can radiate radio frequency energy and, if not installed and used in accordance with the instructions, may cause harmful interference to radio communications. However, there is no guarantee that interference will not occur in a particular installation.

If this equipment does cause harmful interference to radio or television reception, which can be determined by turning the equipment off and on, the user is encouraged to try to correct the interference by one or more of the following measures:

- Reorient or relocate the receiving antenna.
- Increase the separation between the equipment and receiver.
- Connect the equipment into an outlet on a circuit different from that to which the receiver is connected.
- Consult the dealer or an experienced radio/TV technician for help.

To maintain compliance with FCC's RF Exposure guidelines, This equipment should be installed and operated with minimum distance between 20cm the radiator your body: Use only the supplied antenna.

## **Warranty**

THIS WARRANTY IS EXPRESSLY LIMITED TO PERSONS WHO PURCHASE SMARTSAFE PRODUCTS FOR PURPOSES OF RESALE OR USE IN THE ORDINARY COURSE OF THE BUYER'S BUSINESS.

SMARTSAFE electronic product is warranted against defects in materials and workmanship for one year from date of delivery to the user.

This warranty does not cover any part that has been abused, altered, used for a purpose other than for which it was intended, or used in a manner inconsistent with instructions regarding use. The exclusive remedy for any automotive meter found to be defective is repair or replacement, and SMARTSAFE shall not be liable for any consequential or incidental damages.

Final determination of defects shall be made by SMARTSAFE in accordance with procedures established by SMARTSAFE. No agent, employee, or representative of SMARTSAFE has any authority to bind SMARTSAFE to any affirmation, representation, or warranty concerning SMARTSAFE automotive meters, except as stated herein.

### **Disclaimer**

The above warranty is in lieu of any other warranty, expressed or implied, including any warranty of merchantability or fitness for a particular purpose.

### **Purchase Order**

Replaceable and optional parts can be ordered directly from your SMARTSAFE authorized dealer. Your order should include the following information:

- Order quantity
- Part number
- Part name

### **Statement:**

SMARTSAFE reserves the rights to make any change to product designs and specifications without notice. The actual object may differ a little from the descriptions in the manual in physical appearance, color and configuration. We have tried our best to make the descriptions and illustrations in the manual as accurate as possible, and defects are inevitable, if you have any question, please contact local dealer or after-sale service center of SMARTSAFE, SMARTSAFE does not bear any responsibility arising from misunderstandings.