

SENCOR®

SBU 9878BK



UNIVERSAL 5-IN-1 FOOD PROCESSOR

Translation of the original manual



SENCOR®

SBU 9878BK



A

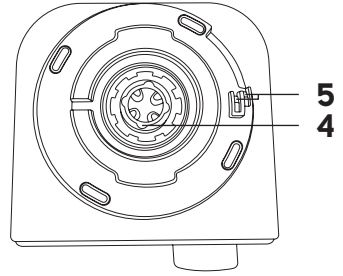
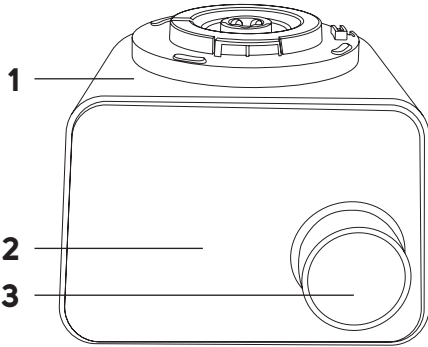

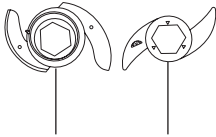
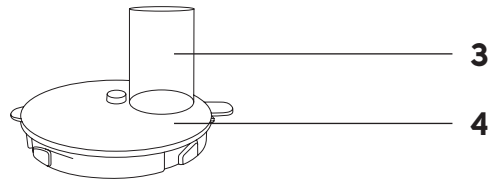
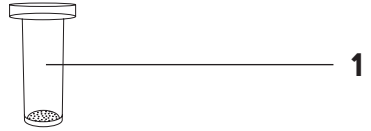
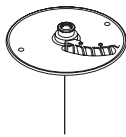
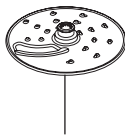
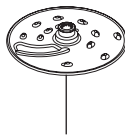
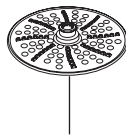
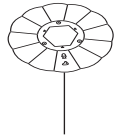
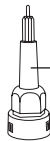
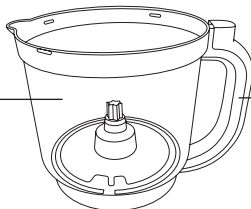
B**5****6****7****8****9****10****11****12****13****14**

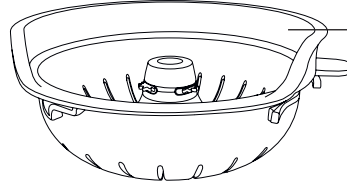
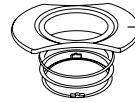
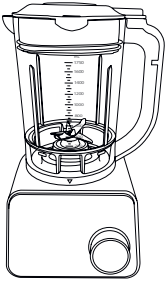
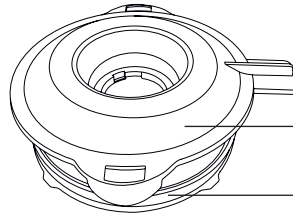
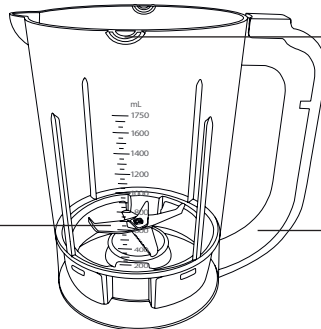
C**1****2****D****1****2****3****4****6****5**

E

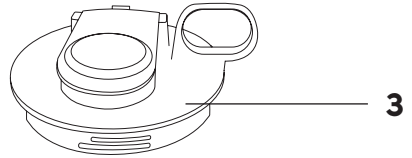
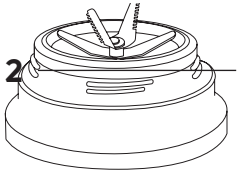
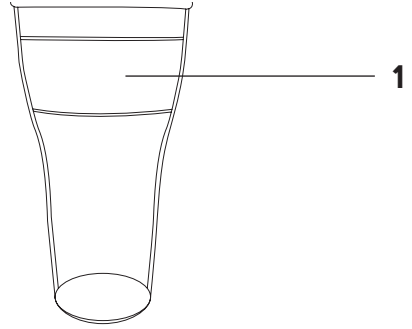

F1

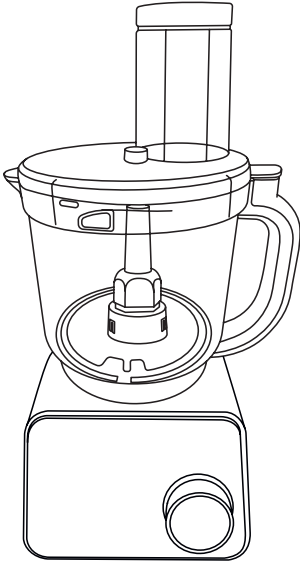

F2

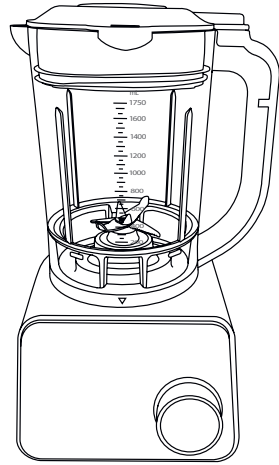

F3

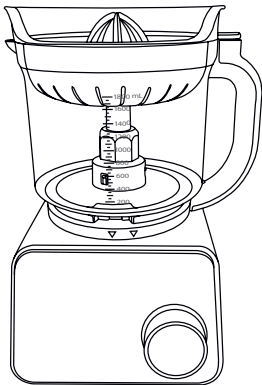

F4

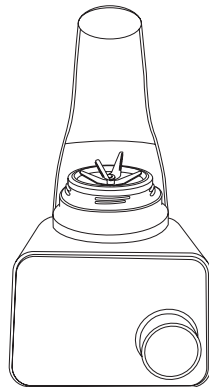

G1



G2

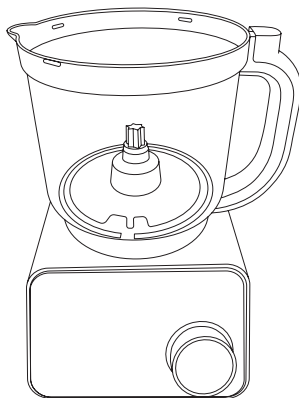

G3

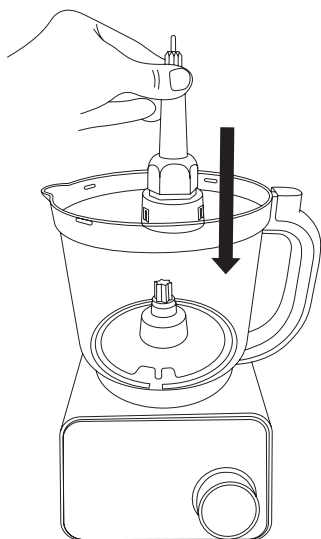

G4

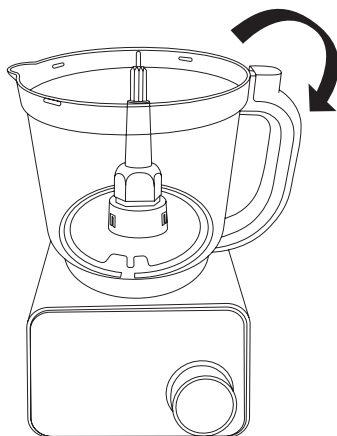

G5

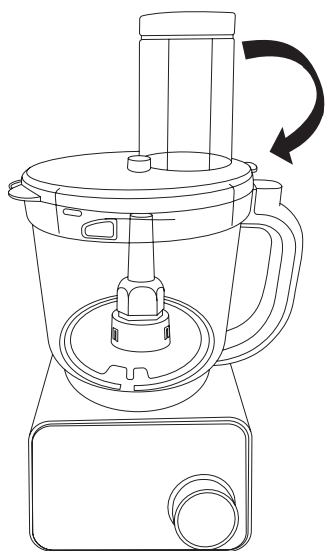

G6

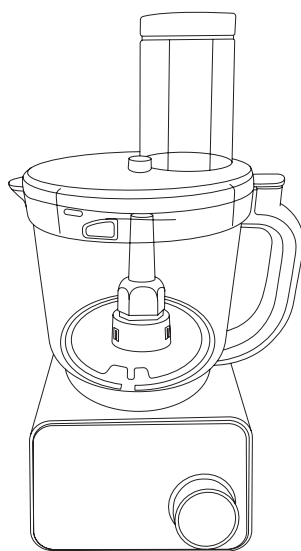

H1

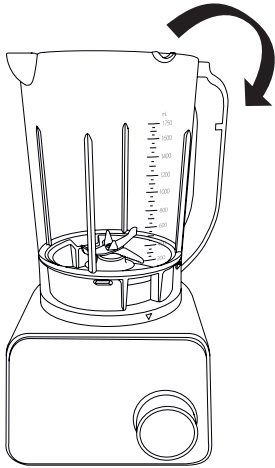

H2

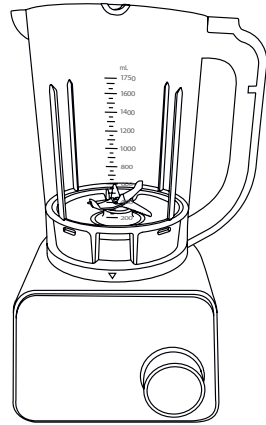

H3

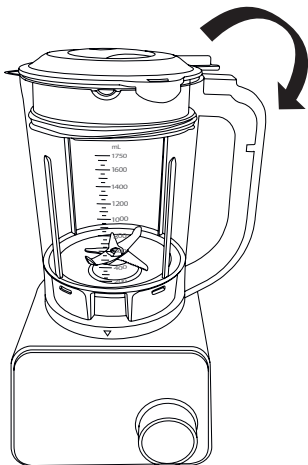

H4

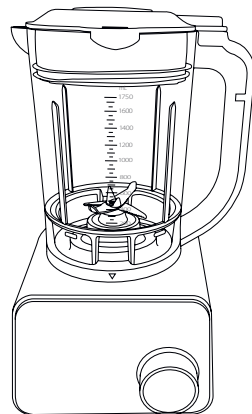

11



12

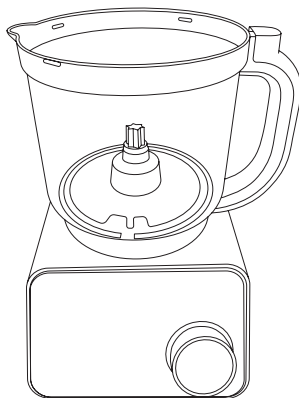

13

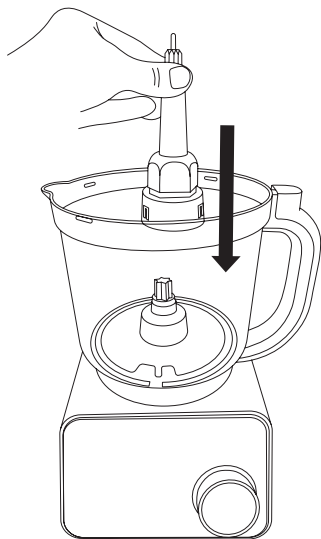

14

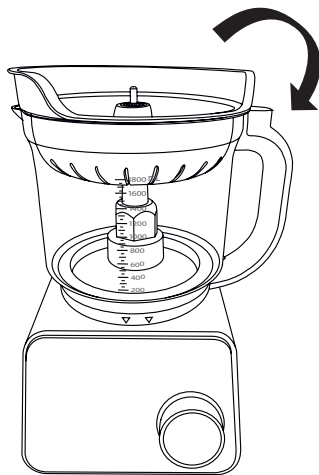

15

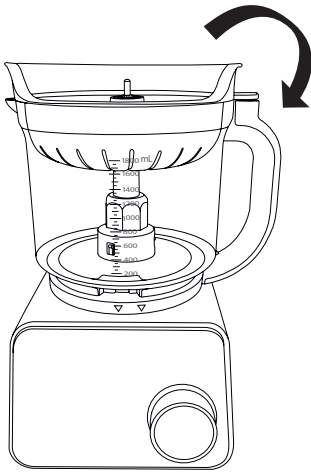

16

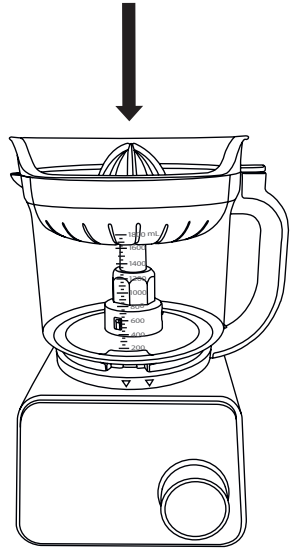

J1

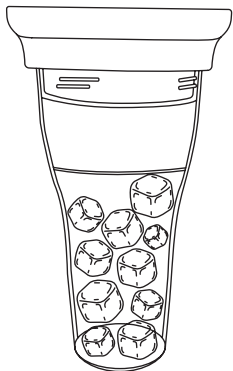

J2

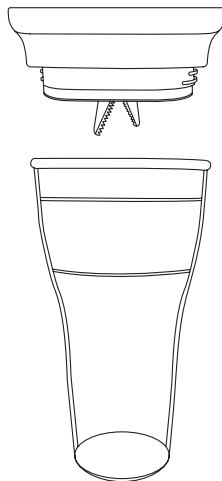

J3

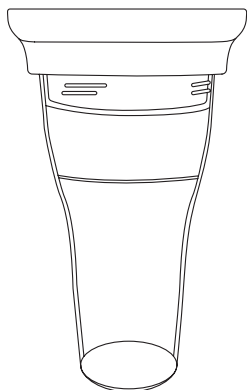

J4

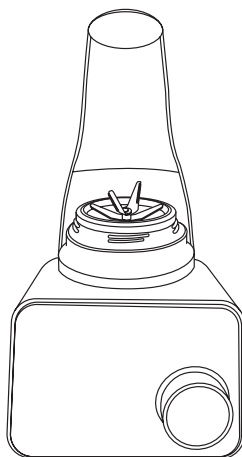

J5

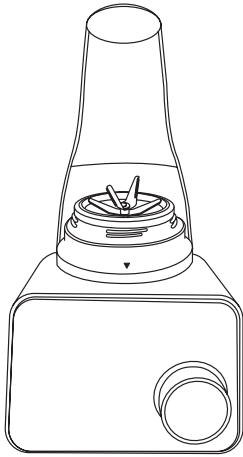

IMPORTANT SAFETY INSTRUCTIONS

READ CAREFULLY AND STORE FOR FUTURE USE.

- This appliance must not be used by children. Keep this appliance and its power cable out of the reach of children.
- The appliance may be used by persons with reduced physical, sensory or mental abilities or lack of experience and knowledge, provided they are supervised or have been instructed on the safe use of the appliance and understand the potential hazards.
- Children must not play with the appliance.
- Cleaning and maintenance must not be carried out by children.
- If the power cord is damaged, have it replaced in a professional service centre in order to prevent a dangerous situation. Never use the appliance if the power cord is damaged.



WARNING:

There is a risk of injury if used incorrectly.

- Pay attention when handling the chopping blades, especially when removing the blades from the container, emptying the container and during cleaning.
- Clean the parts of the appliance that come into contact with food after each use with warm water, kitchen detergent and a soft sponge. Follow the instructions in the "CLEANING AND MAINTENANCE" section.

- Always disconnect the appliance from the power supply when leaving it unattended and before assembly, disassembly or cleaning.
- Before replacing the accessories or accessible movable parts, please turn the appliance off and disconnect it from the power supply.
- Stick to individual preparation times and speed settings mentioned in this manual for the appliances.

Electrical Safety

- Before connecting the appliance to the mains socket, ensure that the voltage stated on its rating plate matches the voltage in the socket.
- Connect the appliance only to a properly earthed socket. Do not use an extension cord.
- Do not connect or disconnect the appliance power cord to or from the mains socket with wet hands.
- Ensure that the plug of the power cord does not come into contact with water or moisture.
- Do not disconnect the appliance from the mains socket by pulling on the power cord. This could damage the power cord or the mains socket. Disconnect the cable from the socket by pulling on the plug of the power cord.
- Do not place heavy objects on the power cord. Ensure that the power cord does not hang over the edge of the table or touch hot surfaces or sharp objects.
- To avoid the danger of injury by electrical shock, do not repair the appliance yourself or make any adjustments to it. Have all repairs or adjustments of the appliance performed at an authorised service centre. Tampering with the appliance during the warranty period may void the warranty.
- Do not spray the appliance with water or any other liquid. Never wash it under running water or submerge it in water or another liquid.
- Always switch off the appliance and disconnect it from the mains socket when you have finished using it.
- This appliance is not designed to be controlled using a programmed device, external timer switch or remote control.

Proper Use of the Appliance

- The appliance is intended and designed for processing a standard amount of food in the household.
- Do not use the appliance for any purpose other than that for which it is intended.
- This appliance is designed for use in indoor areas only. Never use it in outdoor or industrial environment.
- This appliance must only be used in accordance with the instructions provided in this user's manual.
- Use the appliance only with the original accessories supplied with it.



Caution:

The use of non-original accessories can lead to a dangerous situation.

- Do not use sprays, explosive, toxic or flammable substances in the vicinity of the appliance.
- Only place the appliance on an even, dry surface. Do not place the appliance on window sills or on unstable surfaces. Also, do not place it on an electric or gas stove or in its vicinity, do not place it in the vicinity of an open fire or an appliance that is a source of heat.
- Do not use the appliance if it malfunctions, has been dropped on the floor, immersed in water or damaged in any way. Take it to an authorised service centre for inspection or repair.
- It is forbidden to modify the surface of the appliance in any way, e.g. using self-adhesive wallpaper, foil, etc.
- Make sure that the appliance is correctly assembled before putting it into operation. The appliance will not start unless it is assembled correctly.
- Do not disassemble the appliance while powered and in operation.
- Do not handle the appliance if your hands are wet or damp, particularly when inserting the plug into the mains socket and when removing it.
- Do not cover the appliance ventilation openings.
- Do not turn on the appliance when it is empty. Incorrect use of the appliance may negatively affect its lifetime.
- Avoid contact with rotating parts of the appliance.
- Ensure that hair, clothing or other objects do not come into contact with the rotating press cone during operation of the citrus juicer.
- Only place ingredients that are to be processed into the filling opening of the food processor container.
- Never use your fingers or other items to push ingredients through the filling opening. For this purpose there is a pusher included as an accessory.
- Do not attempt to disassemble the appliance during operation.
- No accessories are designed to process boiling ingredients.
- Hot liquids with a temperature of up to 55 °C can be processed in the blender container. Take extra care when handling hot liquids and food. Hot steam or splashing hot liquids and food may cause scalding. Never start the appliance with the blender container attached without the lid properly

secured. If you are processing hot liquids, do not remove the inner lid during operation. Do not touch the hot surface. Use the handle for carrying the heated blender container.

- If you have been processing hot foods, the removable parts may become warm after use.
- Do not process hot or warm ingredients in the food processor container or in the smoothie bottle. Allow these to cool completely before processing.
- The smoothie blender is not designed to crush ice or to process frozen food itself.
- Before attaching attachments to the appliance, removing or replacing them, ensure that the appliance is turned off and disconnected from the mains socket.
- When handling the chopping knife, the blender container with the built-in blade unit, and the smoothie blender blade unit, take extra care to avoid injury from the blades. Particular care must be taken when emptying the blender container, removing the blade unit from the container, removing the grinding blade from the chamber, and cleaning.
- Do not attempt to process bones, nut shells, or other hard ingredients.
- When processing ingredients, follow the recommended usage times for individual accessories listed in this manual. After processing ingredients for the recommended time, allow the appliance to cool down for at least 10 minutes.
- The appliance is equipped with safety fuses that increase safety when using it. If the appliance is not correctly assembled, it will not start. Do not disable safety fuses or attempt to block or intentionally destroy them. There is a risk of serious injury and irreversible damage to the appliance.

Safety During Maintenance

- Always allow the appliance to cool completely before cleaning.
- Clean the appliance regularly after each use according to the instructions in the CLEANING AND MAINTENANCE section. Do not perform any maintenance on the appliance other than the cleaning described in the Maintenance and Cleaning chapter.
- Do not wash the base with the motor unit under running water or immerse it in water or other liquids. This appliance and its parts are not dishwasher safe.
- The removable attachments are intended for short term contact with food (including beverages), i.e. max. 4 hours. Do not leave them submerged, for example in water, for a long time to avoid damaging their finish.

Prevention of Household Accidents

- Hot or boiling liquids pose a significant risk to children, and even minor burns can be serious. Observe basic household injury prevention rules and exercise increased caution when children are near hot or boiling liquids. If necessary, explain to children the risks associated with hot or boiling liquids.
- In the event of burns or scalds, immediately rinse the affected area under a stream of cold water and seek medical assistance if required.

EXPLANATION OF SYMBOLS PLACED ON THE PRODUCT OR IN THE ACCOMPANYING DOCUMENTATION



The product meets all the basic requirements of the applicable EU directives.



This symbol on products or accompanying documents means that used electric or electronic products must not be added to ordinary municipal waste.



Product with protection class II
Electric shock protection is provided by double or heavy-duty insulation.

- Thank you for purchasing our SENCOR product; we hope it will serve to your satisfaction.
- Prior to using this appliance, please read the user manual thoroughly, even in cases when you are already familiar with the use of similar types of appliances. Use the appliance only as described in this user manual. Keep the manual for future reference. If you pass the appliance on to another person, ensure that this user manual is included.
- Carefully unpack the appliance and make sure not to discard any part of the packaging material until you have removed all its components. It is recommended that you keep the original packaging, packing material, receipt and confirmation of the extent of the seller's liability or warranty certificate at least for the duration of the legal right to file a defect claim or the quality warranty. When transporting the appliance, we recommend repackaging it in the original box provided by the manufacturer.

DESCRIPTION OF THE BASE (Fig. A)

- | | |
|--|---|
| A1 Base with motor unit | A4 Connector for attaching accessories |
| A2 Control panel with preset programs | A5 Switching fuses |
| A3 Rotary knob with display | |

DESCRIPTION OF THE FOOD PROCESSOR (Fig. B)

- | | |
|--|--|
| B1 Measuring cup | B9 Reversible disc for slicing / coarse shredding |
| B2 Pusher | B10 Puree disc |
| B3 Filling opening | B11 Mayonnaise maker |
| B4 Food processor container lid | B12 Shaft |
| B5 Chopping knife | B13 2.0 l food processor container |
| B6 Dough knife | B14 Food processor container handle |
| B7 Fries disc | |
| B8 Reversible disc for slicing / fine shredding | |

DESCRIPTION OF THE CITRUS JUICER (Fig. C)

- | | |
|----------------------|---------------------------------|
| C1 Press cone | C2 Flesh collection bowl |
|----------------------|---------------------------------|

DESCRIPTION OF THE BLENDER (Fig. D)

- | | |
|---------------------------------|------------------------------------|
| D1 Inner lid | D4 1.75 l blender container |
| D2 Blender container lid | D5 Blender container handle |
| D3 Gasket seal | D6 Blade unit |

DESCRIPTION OF THE SMOOTHIE BLENDER (Fig. E)

- | | |
|---------------------------------------|-------------------------------|
| E1 600ml smoothie bottle | E3 Smoothie bottle lid |
| E2 Smoothie blender blade unit | |

THE PURPOSE OF USING THE APPLIANCE

- The Sencor SBU 9878BK multifunctional blender is a universal helper for the kitchen, which thanks to its rich accessories will facilitate the preparation of a wide range of meals and drinks.
- The food processor is designed for quick and efficient preparation of ingredients. The chopping knife is ideal for quickly and evenly chopping vegetables, herbs or nuts, while the special dough knife makes it easy to knead and prepare light doughs. Four interchangeable discs allow you to cut into slices and shredding ingredients as needed.
- The citrus juicer provides freshly squeezed juice; the blender container is suitable for preparing soups, sauces or cocktails, and the smoothie

bottle is designed for quick preparation of delicious smoothies that you can take with you for training or a trip to the countryside.

- Thanks to the combination of these functions, the blender can handle the work of several appliances, saving time and space in the kitchen.

QUICK GUIDE AND BASIC CONTROLS (Fig. F)

Your multifunctional blender is supplied with rich accessories for various purposes of use. Always use only one accessory. Accessories cannot be combined and used simultaneously.

Food Processor (Fig. F1)

- The food processor with a chopping knife is suitable for chopping vegetables, herbs or nuts.
- The food processor with a dough knife is suitable for processing various fine or light doughs.
- Thanks to the reversible discs, you can cut the ingredients into slices or grate them according to the required roughness.
- Thanks to the mayonnaise maker, you can easily make your own homemade mayonnaise.
- Assemble the appliance with the food processor and the selected accessories.
- Select one of the preset programs or manually select the processing speed.
- For more information, see the **FOOD PROCESSOR** section of the manual.

Blender (Fig. F2)

- The blender is suitable for quick and effective blending, crushing, mixing and emulsifying various ingredients and preparing dishes and drinks, such as soups, sauces, spreads, dressings or iced drinks. Thanks to powerful blades and high speed, the blender can easily handle fruit, vegetables and ice.
- Assemble the appliance with the blender.
- Select one of the preset programs or manually select the processing speed.
- For more information, see the **BLENDER** section later in the manual.

Citrus Juicer (Fig. F3)







- The citrus juicer is specially designed for juicing oranges, lemons, grapes and other citrus fruits. Just press the fruit on the press cone and you get fresh juice effortlessly. Ideal for quick preparation of vitamin drinks without the use of other appliances.
- Assemble the appliance with the citrus juicer.
- Select one of the preset programs or manually select the processing speed.
- For more information, see the **CITRUS JUICER** section later in the manual.

Smoothie Blender (Fig. F4)

- The smoothie blender is suitable for preparing delicate drinks from fresh fruits, vegetables, dairy products or ice, such as smoothies, cocktails or milkshakes. Thanks to the practical container, which can also be used as a travel bottle, it is ideal for preparing a drink for journeys, to the fitness centres or to work.
- Assemble the appliance with the smoothie blender.
- Select a preset Smoothie program.
- For more information, see the **SMOOTHIE BLENDER** section of the manual.

Pre-set Programs

The SBU 9878BK multifunction blender is equipped with the following preset programs.

PROGRAM	COOKING TIME	PRESET SPEED	DESCRIPTION	ACCESSORIES
Smoothie  Smoothie	60 seconds	10	Suitable for preparing delicate drinks from fresh fruit, vegetables, dairy products or ice, such as smoothies, cocktails or milkshakes	Smoothie blender Blender
Soup  Soup	70 seconds	10	Suitable for making delicate soups, sauces or baby food	Smoothie blender Blender
Slicing and Shredding of Ingredients  Slice & Grate	60 seconds	1	Suitable for cutting and shredding according to the required roughness of various ingredients	Food processor Fries disc Reversible disc for slicing / fine shredding Reversible disc for slicing / coarse shredding Puree disc
Preparing the Dough  Soft Dough	150 seconds	1	Suitable for preparing fine and light doughs	Food processor Dough knife
Citrus Juicer  Citrus Juice	99 seconds	1	Suitable for juicing oranges, lemons, grapes and other citrus fruits	Citrus Juicer
Chopping  Chopping	30 seconds	10	Suitable for chopping various ingredients, vegetables, fruits, herbs or nuts	Food processor Chopping knife

Rotary knob

- The rotary knob is used for continuous adjustment of the speed level from 1 to 10, where 1 represents the lowest speed, while 10 represents the highest speed.

Turning on the Appliance

- After plugging the power cord plug into the mains socket, turn the control once to the right so that the display shows "- -" and ON and the control panel lights up.
- Either press the icon to select one of the preset programs, or turn the control clockwise to manually adjust the speed from 1 to 10.

Turning off the Appliance

- If you have selected a preset program, the appliance will stop automatically after the preset time. If you need to interrupt it earlier, press the icon of the selected program.
- If you have set the speed manually, turn the knob to the left until "- -" and ON are shown on the display.
- Now turn the knob to the left again until OFF shows and the display and control panel turn off.
- Disconnect the power cord from the mains socket.

Safety Fuses

- The appliance is equipped with safety fuses that increase safety when using it. If the appliance is not correctly assembled, it will not start.
- Conversely, if the safety fuse is released during operation, the appliance will stop running immediately.
- Safety fuses are located at the base in the form of switching fuses (see Fig. A, number 5). If the food processor container, blender container or smoothie bottle is not correctly placed in the base, the appliance will not turn on.
- Additional safety fuses are located in the food processor container handle and in the blender container handle. If the food processor container lid, the flesh collection bowl or the blender container lid is not properly secured, the appliance will not turn on. And even if these parts are released, the appliance will stop running immediately.



Caution:

Do not disable safety fuses or attempt to block or intentionally destroy them. There is a risk of serious injury and irreversible damage to the appliance.

BEFORE FIRST USE

- Remove the base and all accessories from the packaging material. Remove any promotional labels or tags. Make sure that no parts are damaged.
- Before storing or disposing of the packaging material, check that you have removed all parts and accessories from the packaging compartments and packaging material.
- Wipe the base with a slightly moistened soft cloth. Wipe with a dry cloth.
- Thoroughly wash the accessories and parts that come into contact with food (see the list below) with warm water using a neutral kitchen detergent and soft sponge or soft brush. Then rinse everything with clean water and allow to dry freely, or wipe dry with a soft cloth.

Accessories and parts suitable for hand washing:

- All food processor parts (Fig. B)
- All parts of the citrus juicer (Fig. C)
- All parts of the blender (Fig. D)
- All parts of the smoothie blender (Fig. E)



Caution:

No part of this appliance is designed to be washed in a dishwasher.



Caution:

Take extra care when handling the chopping knife, discs, the blade unit of the blender container (not removable), the blade unit of the smoothie blender to avoid injury.



Caution:

Do not rinse the base of the appliance, power cord or plug under water or immerse them in water.



Note:

You may notice a slight odour on first use. This is a normal occurrence which disappears with use.

FOOD PROCESSOR

Assembly (Fig. G1–G6)



Caution:

Before assembling or disassembling the food processor, make sure that the appliance is switched off and unplugged from the mains socket. Always wait until the rotating accessories have come to a complete stop.

1. Place the base on a flat, dry, and stable surface, such as a kitchen unit.
2. Place the food processor container on the base and turn the container clockwise so that the handle points to the right.
3. Fit the shaft onto the tip in the centre of the container. Make sure that nothing prevents it from turning.
4. Attach the selected accessories (chopping knife, kneading blade, mayonnaise maker or one of the discs, parts B5 to B11) to the shaft. The chopping knife and dough knife must sit on the bottom of the food processor container. The discs are put on the metal tip of the shaft. If you are going to use a double-sided disc, put it on the side that you are going to use, i.e. if you want to slice, the side of the slicer blade will point upwards.
5. Place the lid on the container and turn it clockwise until you feel resistance. The lid can only be placed on in one way. The protrusion on the lid must fit into the fuse in the handle.
6. Insert the pusher into the filling opening and insert the measuring cup into the pusher.



Caution:



When handling the chopping knife or discs, exercise extreme caution to avoid injury.



Note:

When using a chopping knife or dough knife, first attach the knife to the shaft and then insert the ingredients.

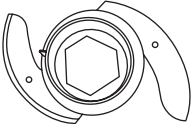
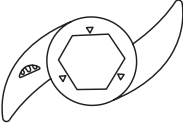
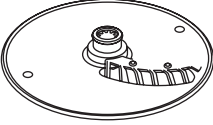
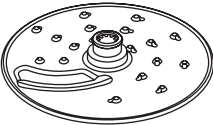
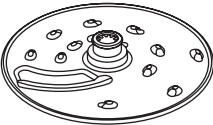
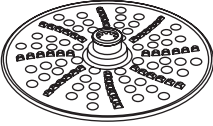
Selecting the food processor attachment

ATTACHMENT	INTENDED USE	SPEED	OPERATING TIME
Chopping Knife 	Suitable for chopping various ingredients, vegetables, fruits, herbs or nuts	10	30 seconds
Dough Knife 	Suitable for preparing fine and light doughs	1	150 seconds
Fries Disc 	Suitable for preparing potato or vegetable fries	1	60 seconds
Reversible Disc for Slicing / Fine Shredding 	Suitable for slicing or grating into thin strips	1	60 seconds
Reversible Disc for Slicing / Coarse Shredding 	Suitable for slicing or grating into thicker strips	1	60 seconds
Puree Disc 	Suitable for preparing purees	10	60 seconds
Mayonnaise maker 	Suitable for homemade mayonnaise	10	60 seconds

Usage

- Unwind the power cord completely and plug the power cord into a properly grounded mains outlet.
- The display will light up briefly and show OFF.
- Turn the knob to the right once to show "- -" and ON on the display and the control panel lights up.
- Either select one of the preset programs, or turn the knob clockwise to manually set the speed from 1 to 10.
- The appliance will start.
- If you going to use a chopping knife or dough knife, put all the ingredients in the container before turning on the food processor.
- If you are going to use discs to process ingredients, carefully remove the pusher after turning on the food processor and insert the ingredients into the filling opening. Using the pusher, slowly push the ingredients through the filling opening.
- Check the condition of the ingredients being processed during preparation.



Caution:

Do not use your fingers or other objects to press the food. Always use the pusher intended for this purpose. Do not insert your fingers or foreign objects into the filling opening.



Tip:

After removing the measuring cup, you will be able to add liquids or add smaller pieces of ingredients directly to the dough. We do not recommend using the opening after removing the measuring cup when using a chopping knife or discs.



Caution:

The food processor container is not intended for processing hot or warm ingredients. Allow them to cool before processing.

Stopping the Operation

- If you have selected a preset program, the appliance will stop automatically after the preset time. If you need to interrupt it earlier, press the icon of the selected program.
- If you have set the speed manually, turn the knob to the left until "- -" and ON are shown on the display.
- Now turn the knob to the left again until OFF shows and the display and control panel turn off.
- Disconnect the power cord from the mains socket.
- Before disassembling the appliance, make sure that the rotating parts have stopped completely.

Interrupting the Operation

- If you need to interrupt the processing of ingredients, e.g. due to the addition or removal of already processed ingredients or there is a blockage of knives/discs, turn off the appliance and disconnect the plug of the power cord from the mains socket. Wait until the rotating parts come to a complete stop.
- Now you will be able to release the lid and mix the ingredients, remove the already processed ones, or add others that did not fit into the filling opening. You will also be able to remove the ingredients that caused the knives/discs to block.
- To continue operation, fit the lid and insert the power cord plug into a mains socket. Select a preset program or set the speed.

Disassembly

1. If possible, move the appliance closer to the kitchen sink or the place where you will clean it.
2. Carefully turn the lid counterclockwise to loosen it. Remove it from the container.
3. Carefully remove the selected accessories (chopping knife, kneading blade, mayonnaise maker or one of the discs, parts B5 to B11) from the metal tip of the shaft.
4. Remove the shaft from the container by pulling it upwards.
5. Turn the food processor container counterclockwise to release it and remove it from the base.

6. After each use, clean the base and parts of the food processor according to the instructions in the **CLEANING AND MAINTENANCE** section.



Caution:

When handling the chopping knife or discs, exercise extreme caution to avoid injury.

BLENDER

Assembly (Fig. H1-H4)



Caution:

Before assembling or disassembling the blender, make sure that the appliance is switched off and disconnected from the mains socket. Always wait until the rotating accessories have come to a complete stop.

1. Place the base on a flat, dry, and stable surface, such as a kitchen unit.
2. Place the blender container on the base and turn the container clockwise so that the handle points to the right.
3. Put the ingredients into the blender container. We recommend cutting larger foods into smaller pieces beforehand.
4. Place the lid on the container and turn it clockwise until you feel resistance. The lid can only be placed on in one way. The protrusion on the lid must fit into the fuse in the handle.



Note:

The maximum capacity of the blender container is 1.75 l. Never fill it above the maximum mark. When processing hot liquids or liquids that increase in volume during blending, we recommend filling the container to a maximum of 2/3 of its maximum capacity.

Usage

- Unwind the power cord completely and plug the power cord into a properly grounded mains outlet.
- The display will light up briefly and show OFF.
- Turn the knob to the right once to show "- -" and ON on the display and the control panel lights up.
- Either select one of the preset programs, or turn the knob clockwise to manually set the speed from 1 to 10.
- The appliance will start.
- Check the condition of the ingredients being processed during preparation.



Tip:

The inner lid can be removed during operation and the ingredients can be added through the lid opening. We recommend lowering the speed before removing the inner lid. Carefully rotate the lid to release it and insert the ingredients through the opening in the inner lid into the container. Put the inner lid back on and turn it until you feel resistance. Now you can increase the speed of the appliance again.

Quick Guide to Processing Ingredients

INGREDIENTS	SPEED SELECTION	RECOMMENDED BLENDING TIME
Fruit, vegetables cut into smaller pieces	8-10	40-50 s
Baby food, side dishes	8-10	30-40 s
Spreads, dressings, marinades	8-10	30-40 s
Smoothies and cocktails	8-10	Max. 60 s
Soups	6-8	Max. 70 s



Note:

The above food processing times are indicative only. The actual blending time depends on the size of the food, its quantity and the required final consistency.

Stopping the Operation

- If you have selected a preset program, the appliance will stop automatically after the preset time. If you need to interrupt it earlier, press the icon of the selected program.
- If you have set the speed manually, turn the knob to the left until “-” and ON are shown on the display.
- Now turn the knob to the left again until OFF shows and the display and control panel turn off.
- Disconnect the power cord from the mains socket.
- Before disassembling the appliance, make sure that the rotating parts have stopped completely.
- Take the processed ingredients out of the bowl using a spatula or a spoon. Never use your fingers. The knife blade is at risk of serious injury.

Interrupting the Operation

- If you need to interrupt the processing of ingredients, e.g. to check the ingredients or wipe them from the walls of the blender container, switch off the appliance and disconnect the power cord plug from the mains socket. Wait until the rotating parts come to a complete stop.
- You can now release the lid. Check the ingredients or use a spatula to wipe the inside walls of the container. Replace the lid.
- Connect the plug of the power cord to a properly earthed mains socket and turn the appliance on to continue processing.

Disassembly

- If possible, move the appliance closer to the kitchen sink or the place where you will clean it.
- Carefully turn the lid counterclockwise to loosen it. Remove it from the container.
- Turn the blender container counterclockwise to release it and remove it from the base.
- After each use, clean the base and parts of the blender according to the instructions in the **CLEANING AND MAINTENANCE** section.



Caution:

Keep hands and fingers away from the blade unit. The knife blade is at risk of serious injury.

CITRUS JUICER

Assembly (Fig. I1–I6)



Caution:

Before assembling or disassembling the citrus juicer, make sure that the appliance is switched off and unplugged from the mains socket. Always wait until the rotating accessories have come to a complete stop.

1. Place the base on a flat, dry, and stable surface, such as a kitchen unit.
2. Place the food processor container on the base and turn the container clockwise so that the handle points to the right.
3. Fit the shaft onto the tip in the centre of the container. Make sure that nothing prevents it from turning.
4. Place the flesh collection bowl on the container and turn the bowl clockwise until you feel resistance. The bowl can only be attached in one way. The protrusion on the bowl must fit into the fuse in the handle.
5. Fit the press cone on the metal tip of the shaft. Turn it slightly when deploying to make sure it is properly deployed and rotates without problems.

Usage

- Unwind the power cord completely and plug the power cord into a properly grounded mains outlet.

- The display will light up briefly and show OFF.
- Turn the knob to the right once to show “-” and ON on the display and the control panel lights up.
- Place the split citrus fruit on the press cone and hold it slightly with one hand.
- Either select one of the preset programs, or turn the knob clockwise to manually set the speed 1. **When using the citrus juicer, it is recommended to use the maximum speed 2.**
- The appliance will start.
- With your hand, hold the citrus fruit on the press cone and at the same time gently press the fruit downwards. The juice will drain into the bowl while the flesh and seeds remain in the bowl.
- Interrupt the operation of the appliance, remove the processed citrus fruit from the press cone, put on another citrus fruit and repeat the procedure.



Caution:

To avoid blockage, do not use excessive force when squeezing the citrus fruit on the press cone. In such an event, turn off the appliance immediately.



Caution:

Keep your fingers, hands, hair, jewellery and loose clothing away from the rotating press cone. Serious injury or damage to the appliance may occur if caught.

Stopping the Operation

- If you have selected a preset program, the appliance will stop automatically after the preset time. If you need to interrupt it earlier, press the icon of the selected program.
- If you have set the speed manually, turn the control to the left until “-” and ON are shown on the display.
- Now turn the knob to the left again until OFF shows and the display and control panel turn off.
- Disconnect the power cord from the mains socket.
- Before disassembling the appliance, make sure that the rotating parts have stopped completely.

Interrupting the Operation

- If you need to interrupt the pressing process, turn off the appliance and disconnect the power cord plug from the mains socket. Wait until the rotating parts come to a complete stop.
- Now you will be able to loosen the bowl, remove excess flesh or pour the juice into the cups.
- To continue operation, fit the bowl and insert the power cord fork into the mains socket. Select a preset program or set the speed.

Disassembly

1. If possible, move the appliance closer to the kitchen sink or the place where you will clean it.
2. Remove the press cone from the shaft tip by pulling upwards. If necessary, carefully rotate the cone to release it.
3. Carefully turn the bowl counterclockwise to loosen it. Remove it from the container.
4. Remove the shaft from the container by pulling it upwards.
5. Turn the food processor container counterclockwise to release it and remove it from the base.
6. After each use, clean the base and parts of the citrus juicer according to the instructions in the **CLEANING AND MAINTENANCE** section.

SMOOTHIE BLENDER

Assembly (Fig. J1–J5)



Caution:

Before assembling or disassembling the smoothie blender, make sure that the appliance is switched off and disconnected from the mains socket. Always wait until the rotating accessories have come to a complete stop.

- Place the base on a flat, dry, and stable surface, such as a kitchen unit.
- Place the ingredients that you wish to process into the smoothie bottle.
- Place the blade unit on the neck of the smoothie bottle and rotate the blade unit clockwise until you feel resistance (the grooves and protrusions on the blade unit and the neck of the smoothie bottle fit together).
- Turn the smoothie bottle upside down and make sure that no liquid is leaking from the smoothie bottle. If yes, the blade unit is not properly fitted. Release it and put it back on the neck of the smoothie bottle.
- Attach the smoothie bottle to the base and turn the bottle clockwise until you feel resistance (the arrow symbol ▼ will point forward).



Caution:

Be extra careful when handling the blade unit to avoid injury.



Note:

The maximum capacity of the smoothie bottle is 0.6 l. Never fill it above the maximum mark. Do not process hot or warm liquids.

Usage

- Unwind the power cord completely and plug the power cord into a properly grounded mains outlet.
- The display will light up briefly and show OFF.
- Turn the control to the right once to show " - " and ON on the display and the control panel lights up.
- Select a preset Smoothie program.**
- The appliance will start.



Note:

The speed can also be set manually. The recommended speed is 10 and the maximum operating time is 60 seconds.



Note:

The smoothie blender is not designed to crush ice or to process frozen food itself.

Stopping the Operation

- The appliance will stop automatically after the preset time. If you need to interrupt it earlier, press the icon of the selected program.
- Now turn the knob once to the left until OFF shows and the display and control panel turn off.
- Disconnect the power cord from the mains socket.
- Before disassembling the appliance, make sure that the rotating parts have stopped completely.
- Remove the smoothie bottle from the base, turn the smoothie bottle upside down and remove the blade unit. Replace the lid so you can take your smoothie with you to work, on a trip or for training.

Disassembly

- If possible, move the appliance closer to the kitchen sink or the place where you will clean it.
- Turn the smoothie bottle counterclockwise to loosen it and remove it from the base.
- Turn the smoothie bottle upside down.
- Turn the blade unit counterclockwise to loosen it and remove it from the bottle neck.
- After each use, clean the base and parts of the smoothie blender according to the instructions in the **CLEANING AND MAINTENANCE** section.



Caution:

Be extra careful when handling the blade unit to avoid injury.

TIPS AND ADVICE

Preparation of Ingredients for Processing

- Meat:** Bone the meat, remove tendons, cartilage and cut it into pieces of approx. 2 × 2 × 6 cm.
- Fruit and Vegetables:** Always wash fruit and vegetables thoroughly. If necessary, peel, remove the peels and cut into such pieces that will pass through the filling opening. Remove hard stones or seeds from fruit such as apricots, peaches, mangoes, etc. Remove the cores and stems from apples, pears, etc. Remove the stems and leaves from the strawberries. Clean the fries thoroughly, wash and peel as needed.
- Remove the shell from the coconut. Only the flesh and water can be processed.
- Soft and juicy fruits such as oranges, mandarins, kiwis, blueberries, tomatoes, etc. can be processed separately in the blender. It depends on the ripeness and juiciness of the fruit.
- Sufficient fluids should be added to less juicy or harder fruits or vegetables. This group includes bananas, apricots, strawberries, mangoes, pineapples, apples, cucumbers, beetroot, etc. Hard vegetables such as carrots can be processed in smaller quantities in combination with softer and juicier fruits or vegetables and sufficient liquids.
- Frozen foods and ice cubes should only be processed with a sufficient amount of liquids. For better results, it is advisable to add even softer ingredients.
- Before inserting into the smoothie blender, cut the ingredients into evenly sized pieces of approx. 1.5–2 cm. If you want to process frozen fruit, slice it before freezing.
- Herbs:** Separate the leaves from the stems and wash as needed.
- Nuts:** Use only nut kernels. Nuts must not be processed in their shell.
- Cheeses:** Cut the hard cheeses into smaller pieces. We recommend that the softer cheeses are cooled down thoroughly before processing.
- Ingredients for the Dough:** Always measure according to the recipe. We recommend pouring liquids gradually through the opening in the pusher after removing the measuring cup. Add the seeds, raisins, chocolate chips, etc. only at the end of the kneading. If the dough is too sticky on the walls of the bowl, add a little flour, while if it is too stiff, add a small amount of liquids (water, milk or oil).

Tips and Advice for Blending

- Foods with a solid consistency, such as fruit or vegetables, should first be cut into smaller pieces about 3 cm in size before blending them.
- First blend a smaller amount of ingredients and gradually add more ingredients through the opening in the lid during blending. This will achieve better results than if you put all the ingredients into the blender container at once.
- If you need to process solid consistency foods at the same time as liquids, we recommend first blending the solid consistency foods and some of the liquids. Then gradually add the rest of the liquids through the opening in the lid during blending.
- For blending very thick liquids, we recommend running the blender repeatedly at short intervals.
- Ice cubes need to be processed immediately after removal from the freezer. Once the ice starts to melt, the cubes will join together and it will not be possible to blend them.

Tips and Advice for Juicing Fruit

- Choose ripe juicy fruits. The heavier fruit usually contains more juice.
- Thoroughly wash chemically treated fruits before use.
- Keep citrus fruits at room temperature. Less juice can flow out of the chilled fruit.
- Roll them on the table with your hand before pressing. This will disrupt the flesh and make the juice easier to release.
- Always cut the citrus fruits across (not longitudinally).
- Remove the stones, if possible.
- Press the citrus fruits just before consumption. Fresh juice quickly oxidises and loses vitamin C.
- When pressing, do not apply excessive force on the press cone. Excessive squeezing may cause the peel of the citrus fruit to break and the bitter essential oils to get into the fresh juice.



CLEANING AND MAINTENANCE

- Before cleaning, switch off the appliance and unplug the power cord from the mains socket. Allow the appliance to cool down.
- Clean the base and used accessories immediately after use. Do not allow food residues to dry out.



Caution:

To prevent the risk of electric shock, do not immerse the appliance, power cable, or plug into water or any other liquid.



Caution:

Do not use abrasive cleaning agents, solvents, etc. to clean any parts of the appliance, as these could damage the surface. None of the components of this appliance are dishwasher safe.



Caution:

Do not use scouring pads (metal or plastic) to clean any parts of the appliance. They can scratch the surface and damage its finish.

Base

- Wipe the base with a slightly moistened soft cloth. Wipe with a dry cloth.

Accessories

- Thoroughly wash the accessories and parts that come into contact with food (see the list below) with warm water using a neutral kitchen detergent and soft sponge or soft brush. Then rinse everything with clean water and allow to dry freely, or wipe dry with a soft cloth.

Accessories and parts suitable for hand washing:

- All food processor parts (Fig. B)
- All parts of the citrus juicer (Fig. C)
- All parts of the blender (Fig. D)
- All parts of the smoothie blender (Fig. E)



Caution:

No part of this appliance is designed to be washed in a dishwasher.



Caution:

Take extra care when handling the chopping knife, discs, the blade unit of the blender container (not removable), the blade unit of the smoothie blender to avoid injury.

Tips and Advice for Cleaning and Maintaining Accessories

- You can also use a brush with soft bristles to clean and remove food residues.
- You can easily clean the blender container or smoothie bottle by filling it with 0.5 l of clean water with a few drops of dishwashing detergent, then assembling the appliance and running it for 10 to 15 seconds. Then turn off the appliance, unplug it from the mains, and remove the accessories once the rotating parts have stopped. Pour out the contents of the container or bottle, then rinse the container/bottle thoroughly with clean water and wipe dry. Use a brush with a long handle to remove any food residue under the blades of the blade unit.
- Rinse the discs for fries, grating, or slicing, and the puree disc under running water using a brush.

STORAGE

- Before storage, the appliance and its accessories must be completely cool, switched off and disconnected from the power supply, clean and dry.

- Store the base and all accessories in a clean, dry place out of the reach of children. Do not store the appliance folded. Do not place any accessories or foreign objects on the base.

TECHNICAL SPECIFICATIONS

Rated voltage range.....	220–240 V–
Rated frequency.....	50/60 Hz
Rated input.....	1,500 W
Food processor container capacity.....	2.0 l
Blender container capacity.....	1.75 l
Smoothie bottle capacity.....	0.6 l
Noise level.....	85 dB(A)

Values Provided according to Commission Regulation EU 2023/826

Off Mode	
Power consumption in off mode	0.5 W
Time needed for the equipment to automatically reach off mode	0 min
Standby Mode	
Power consumption in Standby mode	–
Time needed for the equipment to automatically reach standby mode	–
Networked Standby Mode (Wi-Fi)	
Power consumption in networked standby	–
Time needed for the equipment to automatically reach networked standby mode	–

INSTRUCTIONS AND INFORMATION ON DISPOSAL OF USED PACKAGING MATERIAL

Dispose of used packaging material at the designated municipal waste disposal site.

DISPOSAL OF USED ELECTRICAL AND ELECTRONIC EQUIPMENT

Used electrical and electronic products must not be disposed of in ordinary municipal waste. To enable the proper disposal, renewal and recycling of these products, deliver them to the designated collection points. Alternatively, in some European Union states or other European countries the products can be returned to the local retailer when buying an equivalent new product. By disposing of this product correctly, you help to conserve valuable natural resources and prevent any potential adverse impact on the environment and human health that could result from improper waste disposal. For more details, contact your local authority or nearest collection point. Fines may be imposed for the improper disposal of this type of waste as per national regulations.

For business entities in European Union States

If you wish to dispose of electrical and electronic equipment, please request the necessary information from your retailer or supplier.

Disposal in other countries outside the European Union

To dispose of this product elsewhere, request the necessary information on the correct disposal method from local authorities or your retailer.

Changes to text and technical parameters are reserved.

FAST ČR, a.s.
U Sanitasu 1621
CZ-251 01 Říčany
www.sencor.com
info@sencor.cz