

Body-Solid[®]
Built for Life

GS-348Q

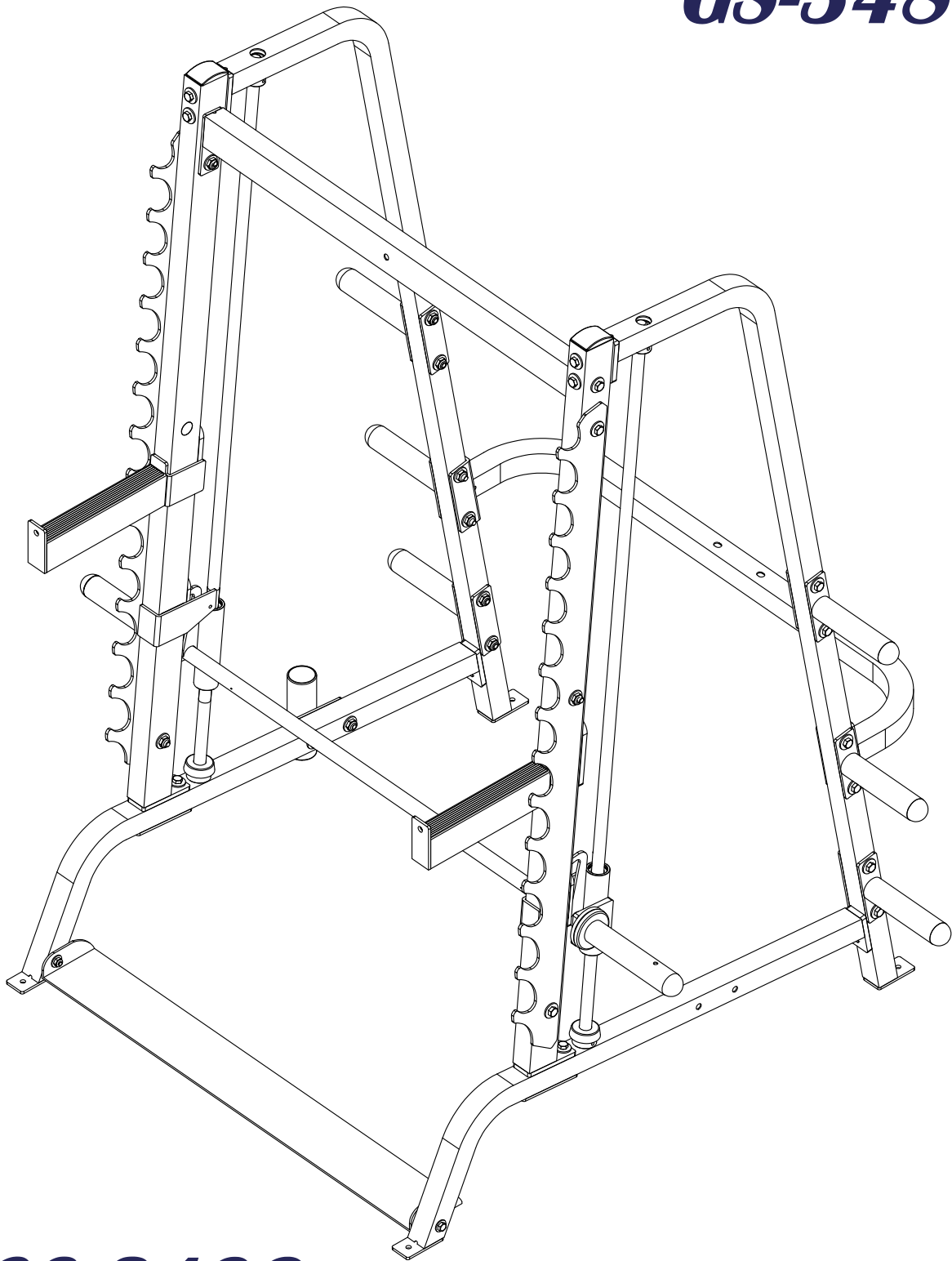

GS-348Q

VERSION **190828**

GS348Q

Reference Drawings

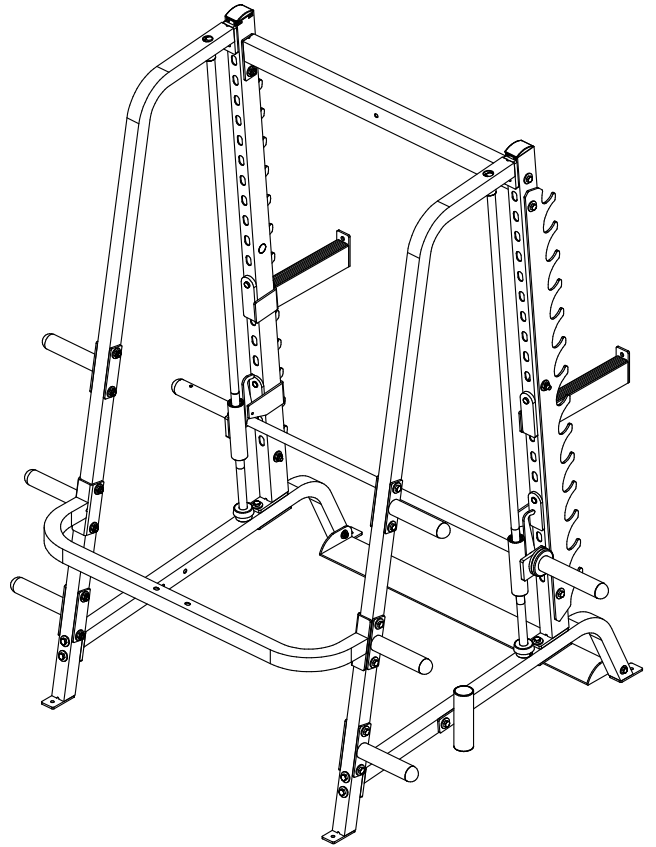
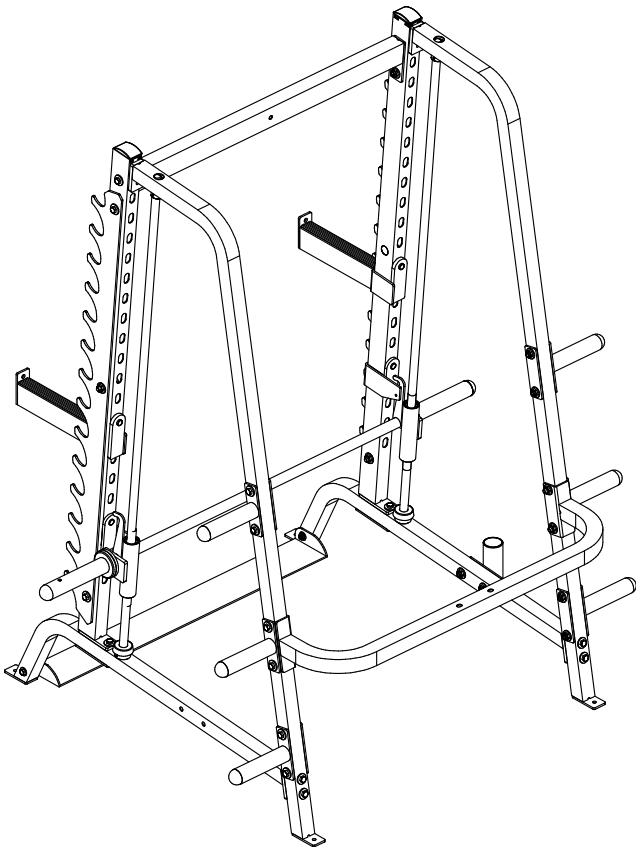
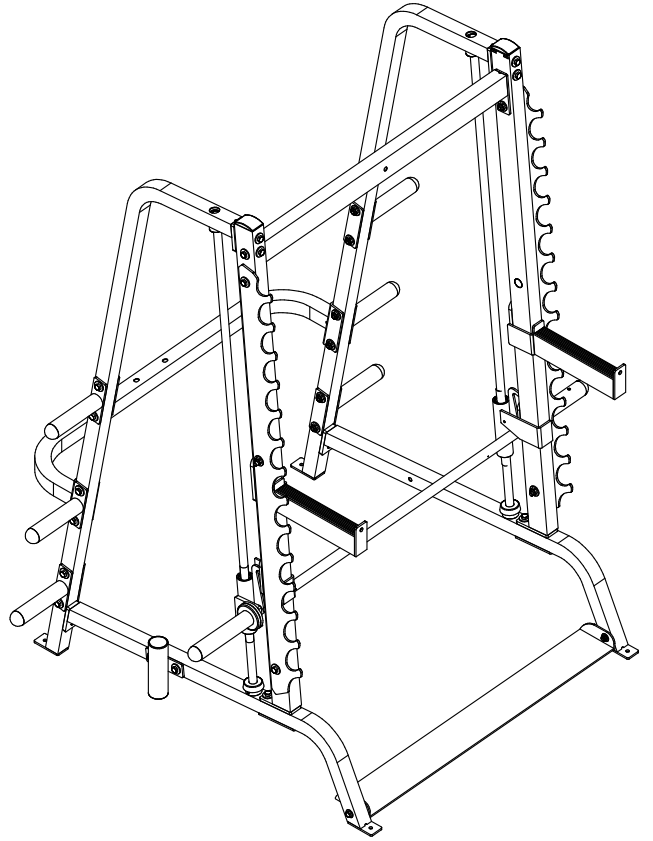
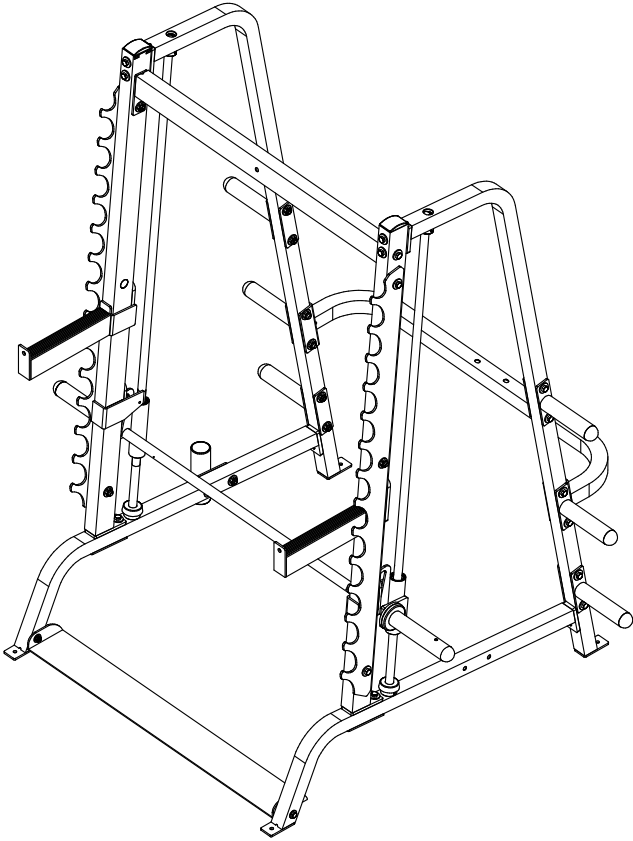

GS348Q Reference Drawings

Minimum Usage Spaces

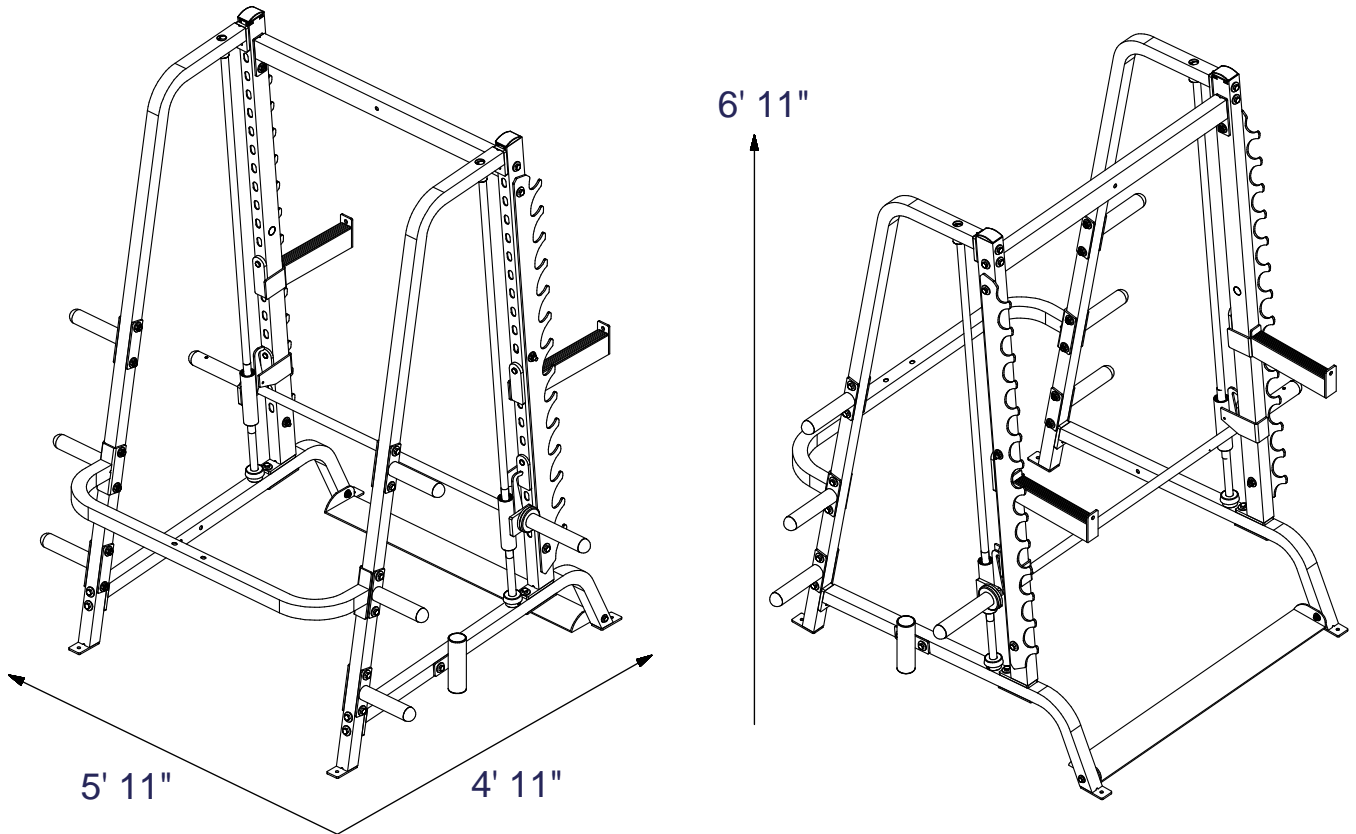

Suggested Usage Spaces

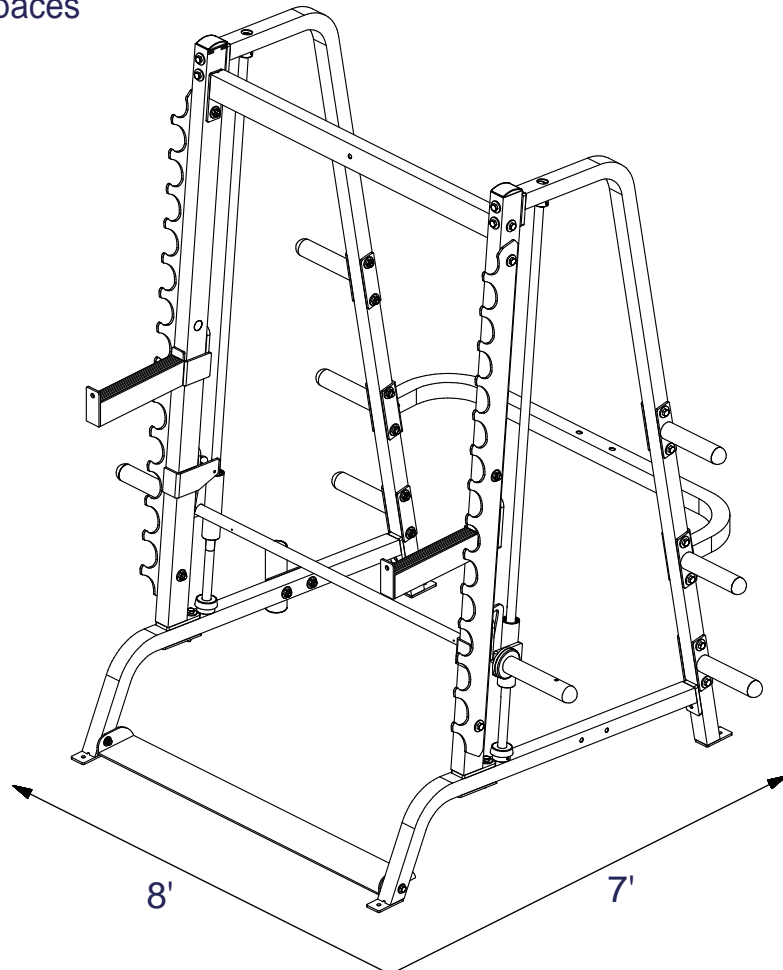

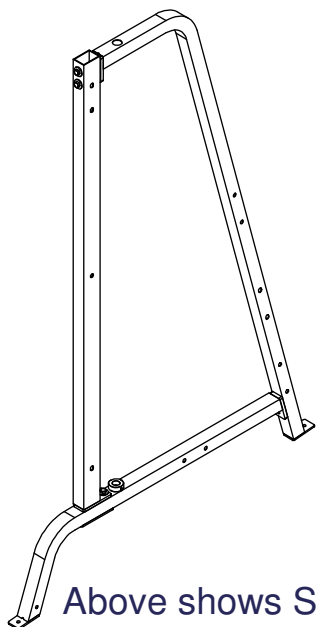

Above shows STEP 1
assembled and completed

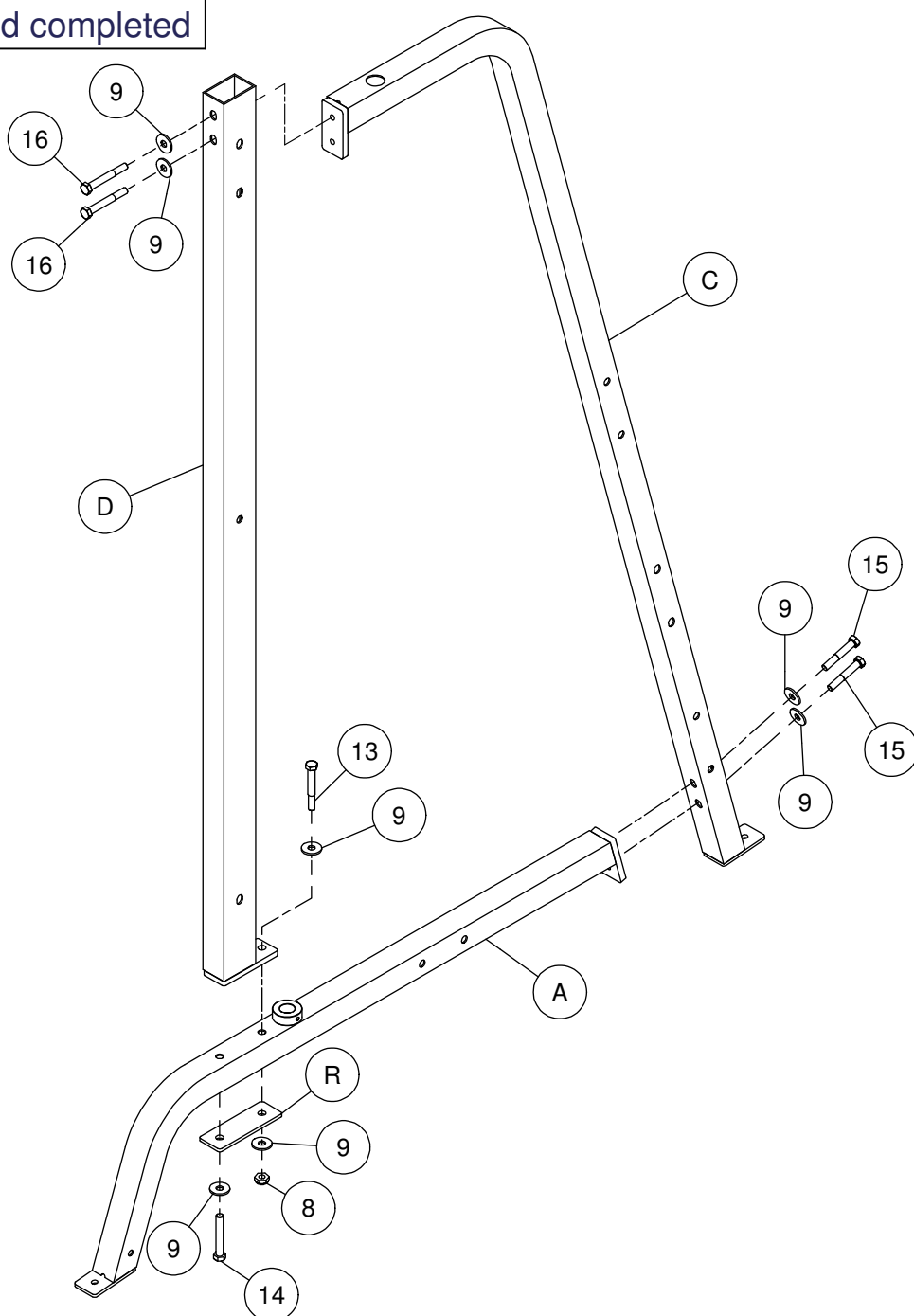

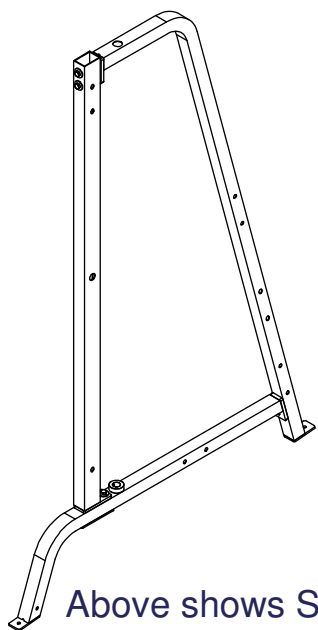

Above shows STEP 2
assembled and completed

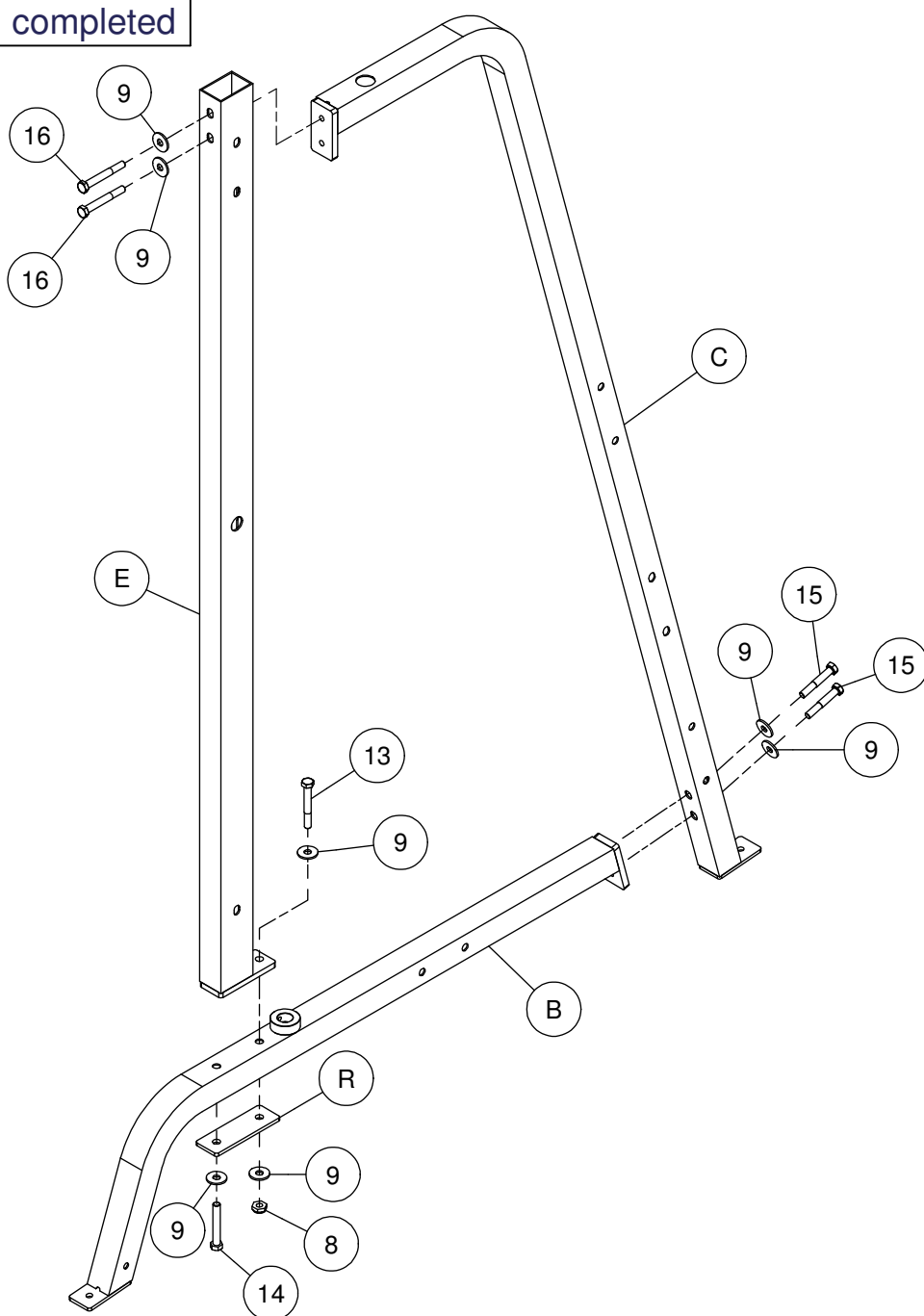

STEP
3

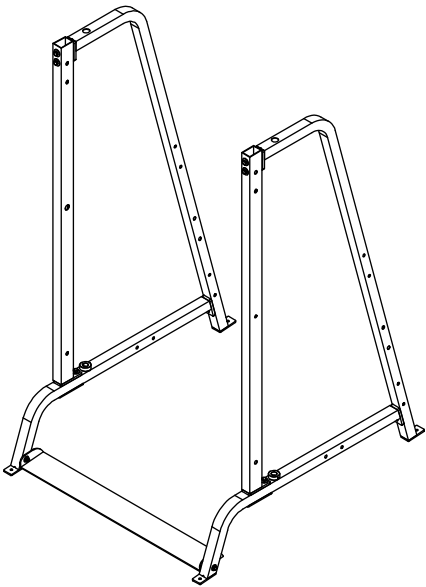

Above shows STEP 3 assembled and completed

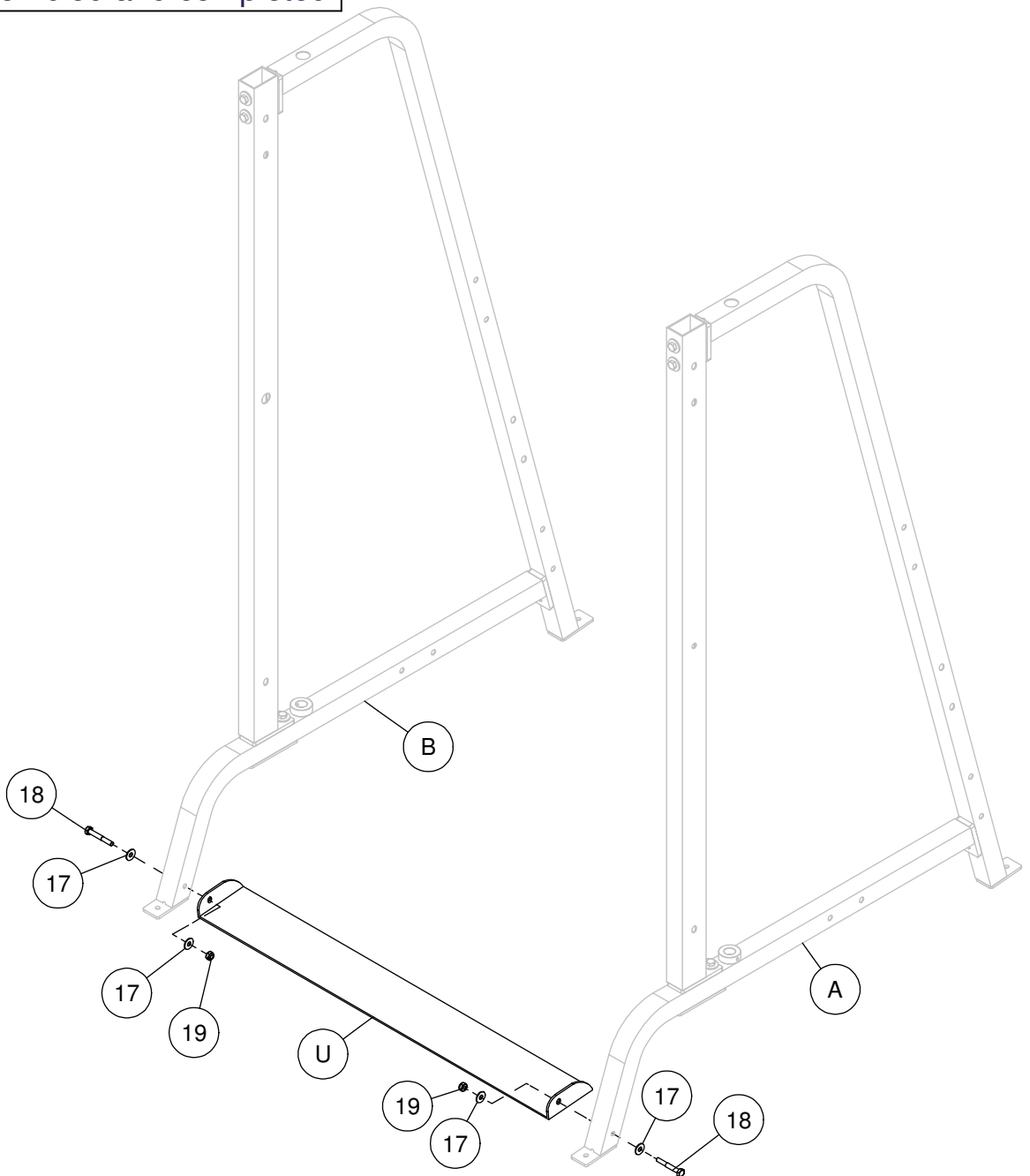

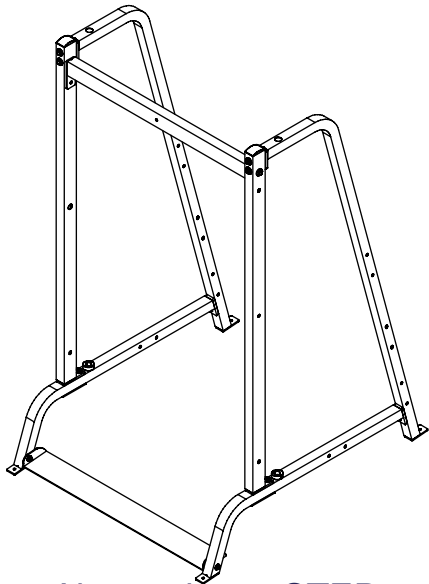

Above shows STEP 4 assembled and completed

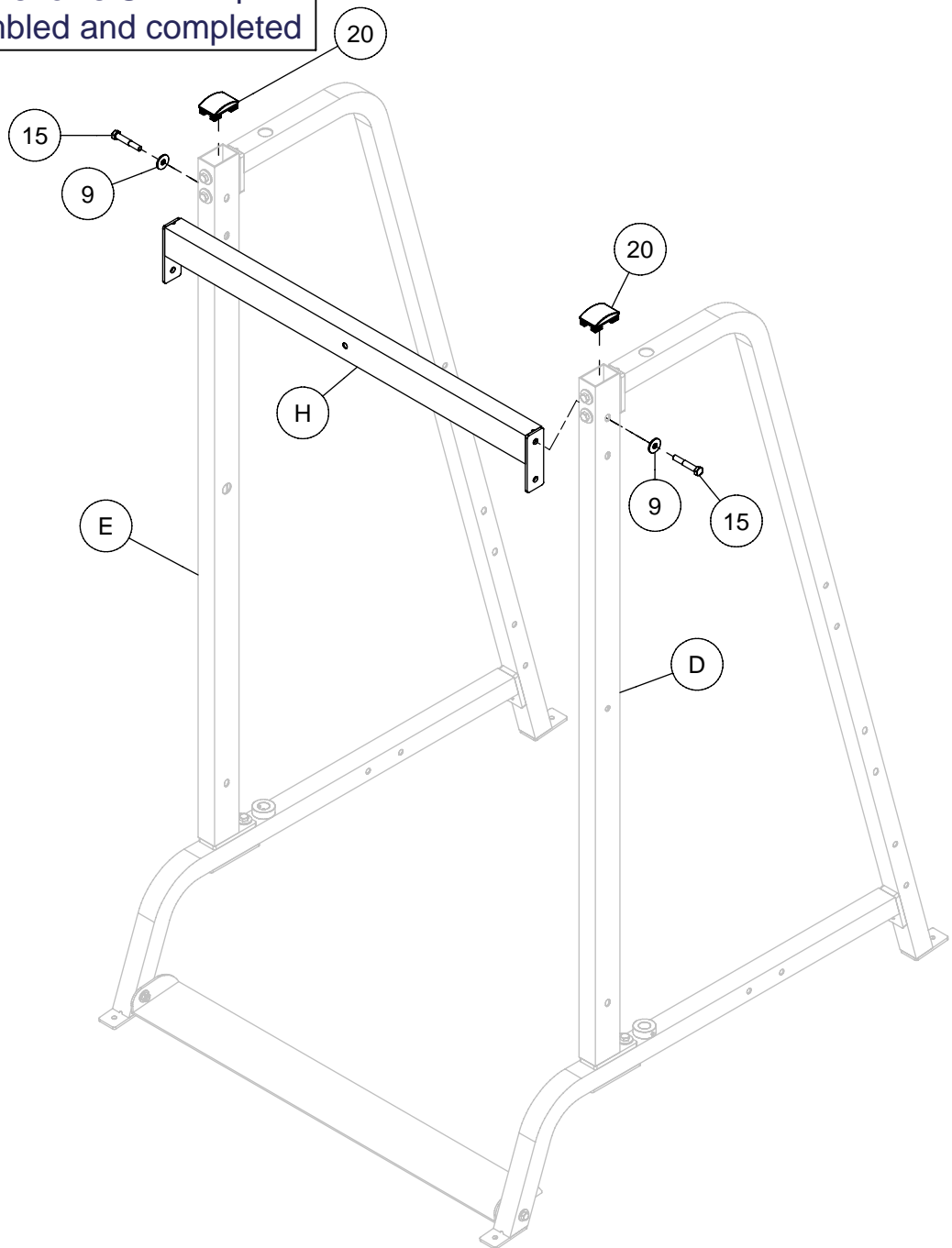

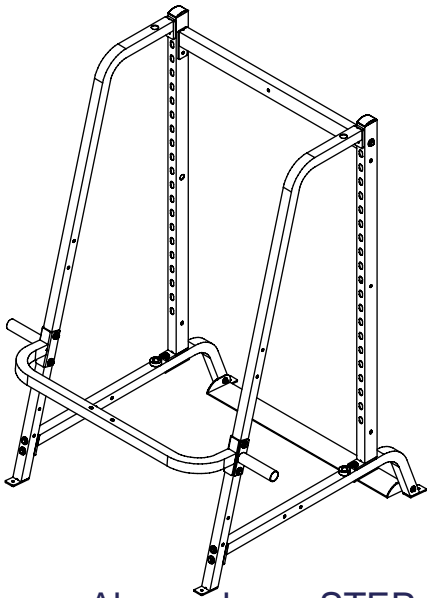

Above shows STEP 5 assembled and completed

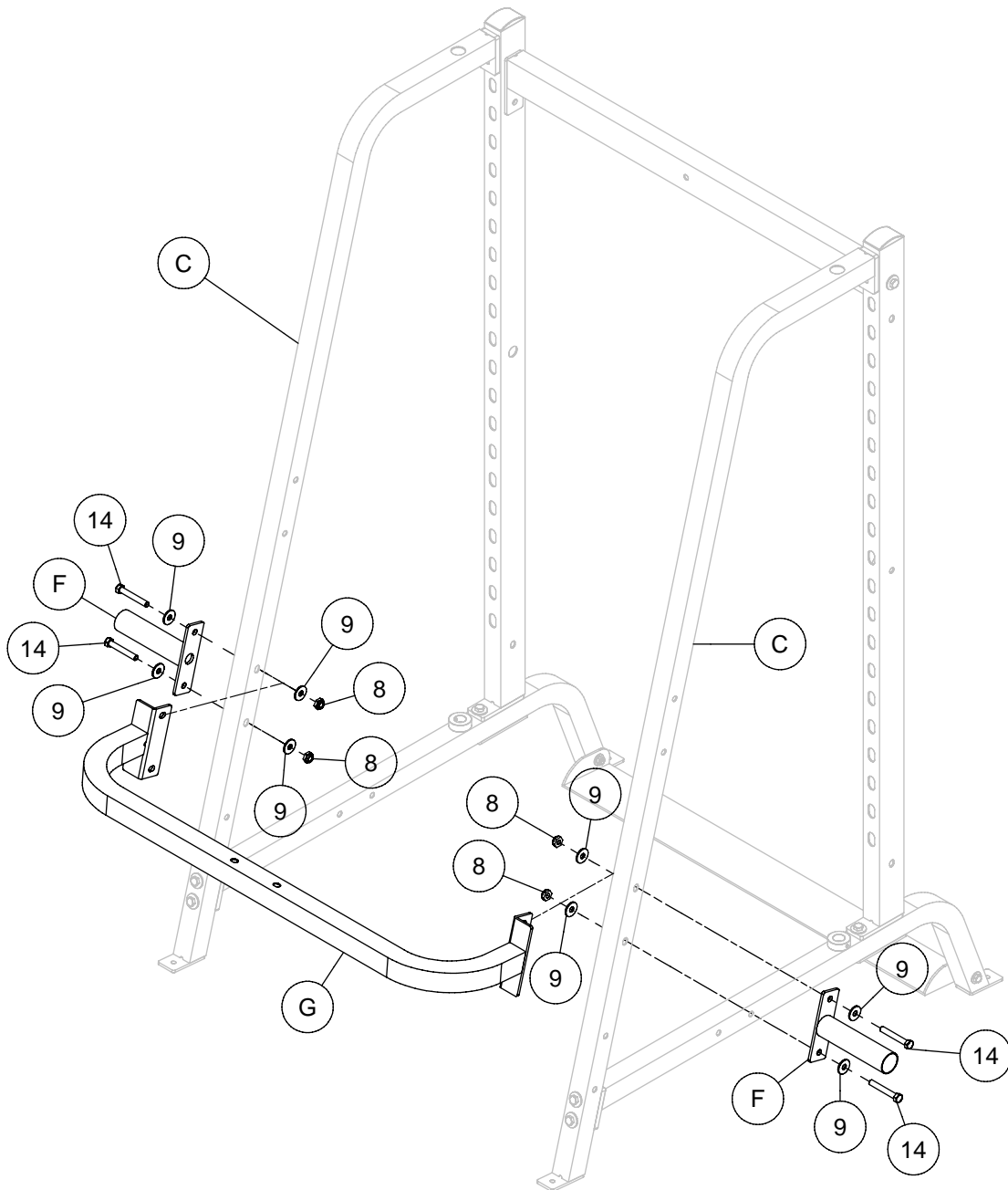

STEP
7

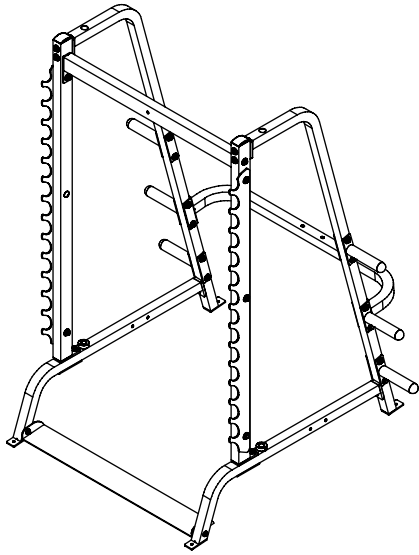

Above shows STEP 7 assembled and completed

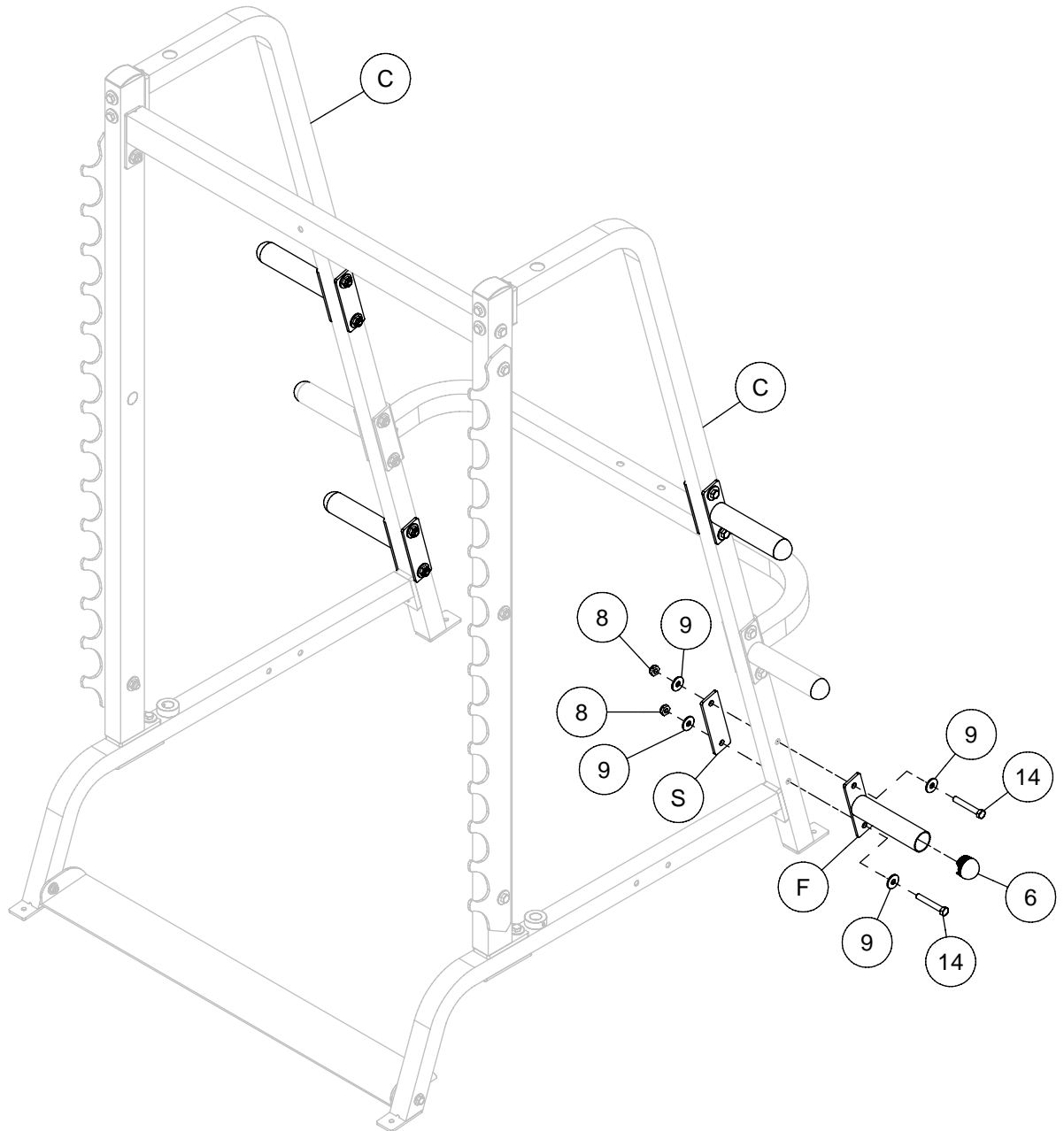

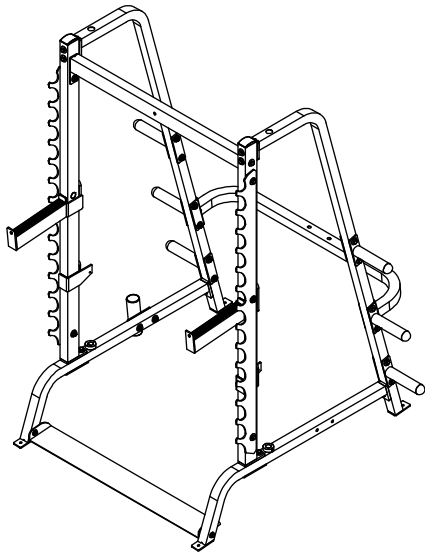

Above shows STEP 8 assembled and completed

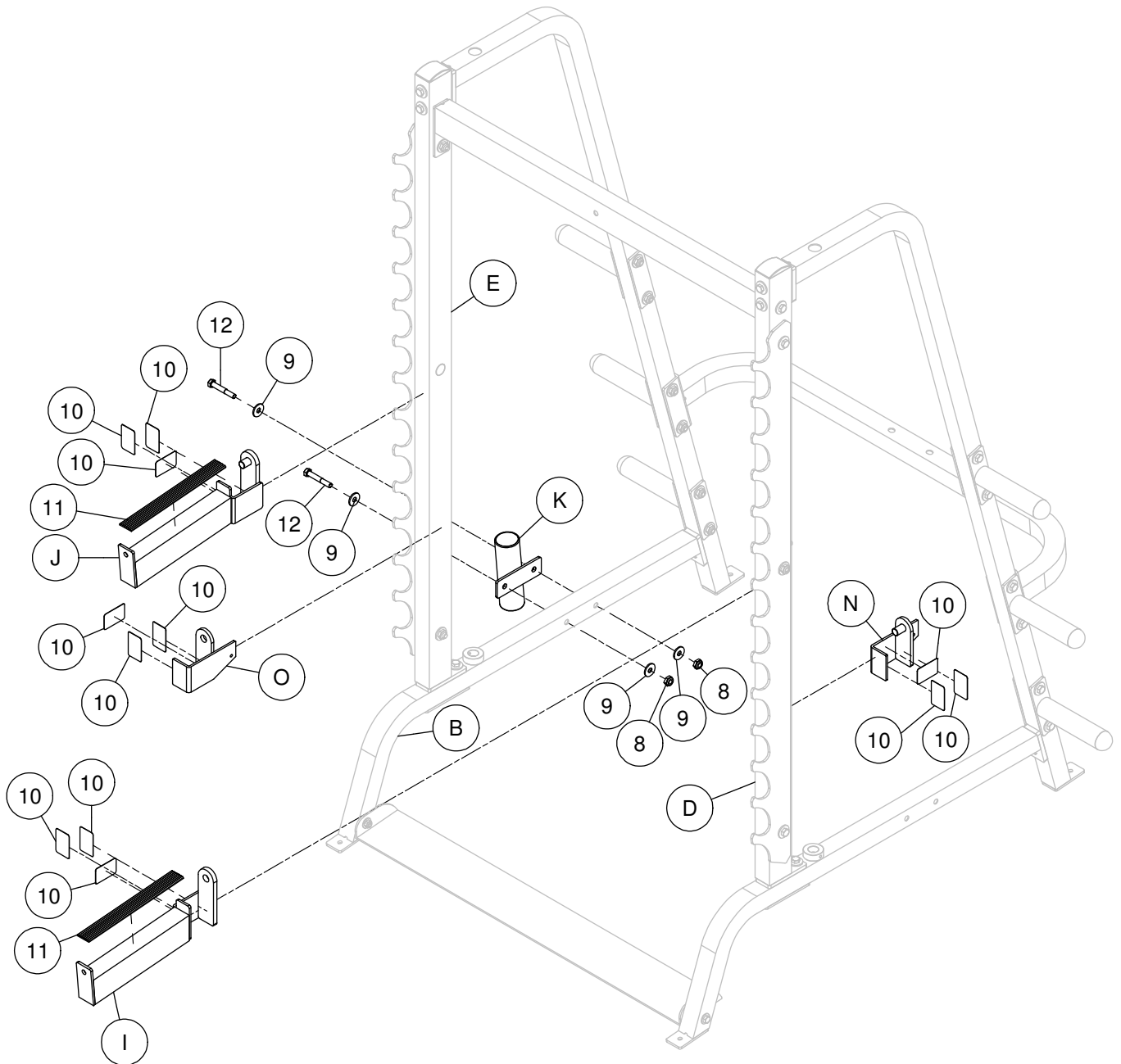

GS348Q Mainframe Parts List

KEY#	QTY	DESCRIPTION		
A	1	RIGHT ASSISTANT SUPPORTED FRAME		
B	1	LEFT ASSISTANT SUPPORTED FRAME		
C	2	MAIN FRAME		
D	1	RIGHT ADJUSTABLE VERTICAL FRAME		
E	1	LEFT ADJUSTABLE VERTICAL FRAME		
F	6	WEIGHT RACK		
G	1	BACK FIXED CROSSPIECE		
H	1	FIXED CROSSPIECE		
I	1	RIGHT WEIGHT SUPPORT FRAME		
J	1	LEFT WEIGHT SUPPORT FRAME		
K	1	FIXED FRAME		
L	2	WEIGHT FRAME (pre-installed)		
M	1	POTHOOK FRAME		
N	1	LEFT SAFETY FRAME		
O	1	RIGHT SAFETY FRAME		
P	2	CHROME GUIDE ROD	Ø25x1840L	(8280-018)
Q	1	LEFT SELECTOR PIECE		(8343-056)
R	2	FLAT PLATE	50X6tX150L	(8312-062)
S	4	FLAT PLATE	50X6TX170L	(8312-091)
T	1	RIGHT SELECTOR PIECE		(8343-056)
U	1	FOOT PLATE		(8370-030)

GS348Q Hardware List

KEY#	QTY	DESCRIPTION		
1	2	RUBBER DONUT	Ø2 1/2"X19t	(9310-012)
2	4	SEALED BEARING	TB-25UU TSK	(8510-017)
3	4	RETAINING RING		
4	2	TRANSPARENT PIPE	Ø25X280L	(9211-059)
5	4	RUBBER DONUT	Ø90X10t	(9310-016)
6	8	ROUND END CAP	Ø50	(9211-074)
7	2	SHAFT COLLAR	Ø1"	(9211-064)
8	22	NYLON LOCK NUT	M12	
9	60	WASHER	M12	
10	12	PASTER	45X70L	(9440-068)
11	2	RUBBER PAD	38X325L	(9310-042)
12	2	HEX HEAD BOLT (PARTIAL THREAD)	M12X75L	
13	4	HEX HEAD BOLT (PARTIAL THREAD)	M12X85L	
14	16	HEX HEAD BOLT (PARTIAL THREAD)	M12X80L	
15	6	HEX HEAD BOLT (PARTIAL THREAD)	M12X70L	
16	4	HEX HEAD BOLT (PARTIAL THREAD)	M12X90L	
17	4	WASHER	M10	
18	2	HEX HEAD BOLT (PARTIAL THREAD)	M10X70L	
19	2	NYLON LOCK NUT	M10	
20	2	CONVEX END CAP	50X75	(9211-084)
21	2	ALLEN HEAD BOLT (FULL THREAD)	M12X25L	
22	2	ROUND END CAP	Ø26	(9211-069)
23	1	WARNING STICKER		(9440-021)
24	1	BODYSOLID LOGO		(9440-027)
25	2	RIGHT STICKER		(9440-053)
26	2	LEFT STICKER		(9440-054)
27	2	NUMBER STICKER		(9440-072)
28	2	WARNING STICKER		(9440-079)
29	1	MAINTENANCE STICKER		(9440-103)
30	1	WARNING STICKER		(9440-105)
31	1	BODYSOLID PLATE		(9440-199)
32	1	WARNING STICKER		(9440-217)
33	1	TOUCH-UP PAINT (DARK GRAY)		
34	1	TOUCH-UP PAINT (SILVER)		
35	2	SUNK SCREW	M8X8	

GS348Q HARDWARE

(shown in actual size)

Part# 12. M12X75L Hex Head Bolt-----[2PCS]

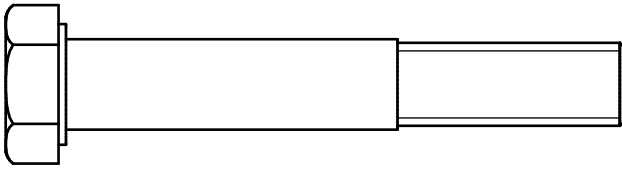

Part# 13. M12X85L Hex Head Bolt-----[4PCS]

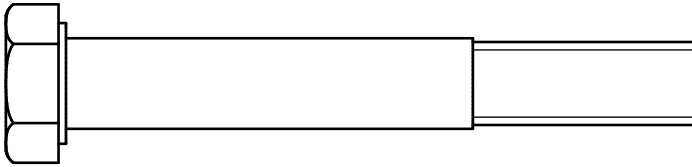

Part# 14. M12X80L Hex Head Bolt-----[16PCS]

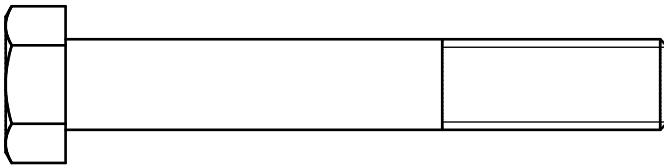

Part# 15. M12X70L Hex Head Bolt-----[6PCS]

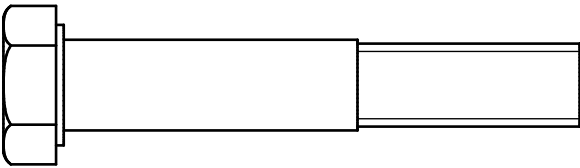

Part# 16. M12X90L Hex Head Bolt-----[4PCS]

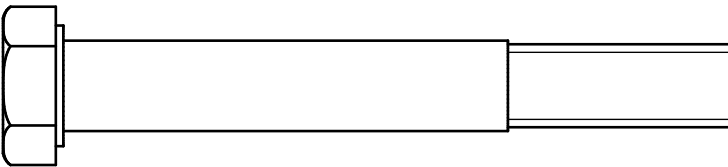

Part# 18. M10X70L Hex Head Bolt-----[2PCS]

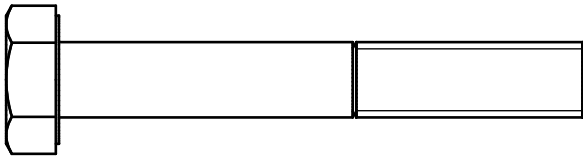

Part# 21. M12X25L Inner Hex Screw-----[2PCS]

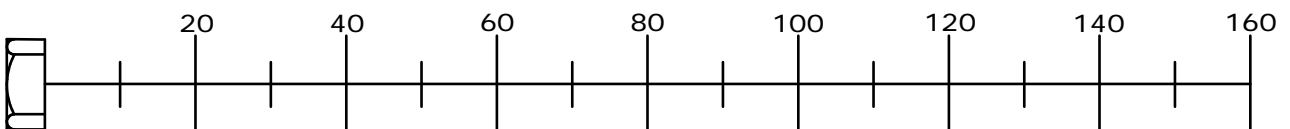
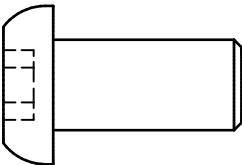

GS348Q HARDWARE

(shown in actual size)

Part# 8. M12 Nylon Lock Nut-----[22PCS]

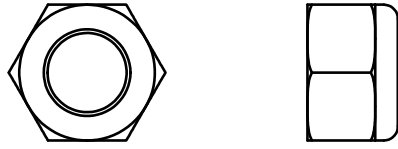

Part# 19. M10 Nylon Lock Nut-----[2PCS]

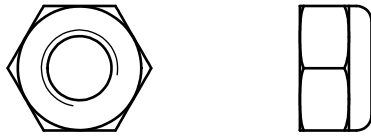

Part# 9. M12 x n34 OD WASHER-----[60PCS]

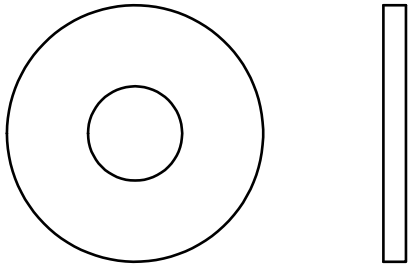

Part# 17. M10 x n27 OD WASHER-----[4PCS]

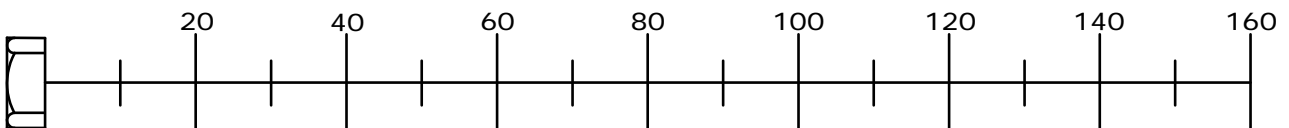
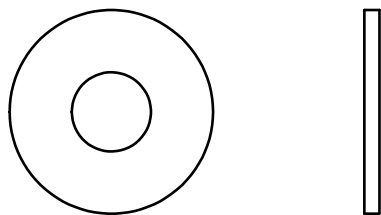



EXPLODED VIEW DIAGRAM GS348Q

