

CBS-1231 & CBS-1232 Extractor Plus Brewing System
FETCO PLUS® Commercial Beverage Equipment



CBS-1232 & CBS-1231 3.0-4.0 Extractor Plus Brewers, shown with 2.2 liter Air Pot (sold separately)



CONTACT INFORMATION

FETCO® FOOD EQUIPMENT TECHNOLOGIES COMPANY
600 ROSE ROAD
LAKE ZURICH • IL • 60047-0429 • USA
ON THE WEB fetco.coffee



fetco.com

©2020-2021 FOOD EQUIPMENT TECHNOLOGIES COMPANY
PATENTS: <https://www.fetco.com/pl/pages/patents,74.html>

PHONE: (800) 338-2699 (US & CANADA)
(847) 719-3000 (All Countries)
FAX: (847) 719-3001
EMAIL: sales@fetco.com
orders@fetco.com (to order parts and equipment)
techsupport@fetco.com (all service queries)
P211 REV. 000 November 2021

Coffee Brewer: CBS-1230 series

TABLE OF CONTENTS

Specifications and Requirements	2	F Service Menu	10
Electrical and Output Specifications	3	F Error Codes	11
Starting The Brew	4	G Counters	12
The Brew Sequence	4	H Save & Exit	13
Enter Programming	4	Operator Training	14
Programing Menu Layout	5	Brewer Setup	17
A Program	6	Parts Diagram CBS-1231	18
B General	7	Parts Diagrams CBS-1232	20
C Service Inputs	8	CBS-1231 Tank Assembly	22
D Service Outputs	8	CBS-1232 Tank Assembly	24
E Calibration	9	Wiring Diagrams	27

Specifications and Requirements

Water Requirements:

CBS-1231 & 1232: 20-75 psig, (138-517kPa) 1½gpm/(5.7lpm)

Water inlet fitting is a 3/8 inch male flare.

Brewer supplied with inlet valve adaptor for BSP to SAE

Brew Volume: Full Batch 3.8 liters; second batch 2.9 liter)

User adjustable from 0.95 liter to 4.75 liters per brew

Total Brew Cycle—Factory default setting: First batch: 5:30 minutes=[4 minute brew time + 1.30 minute drip delay]

Second batch: 5:00 minutes=[3:30 minute brew time + 1:30 minute drip delay]

Brew-Process parameters are user controllable for:

Brew Volume, Brew Time, Prewet Percent and Prewet Delay, Drip Delay

Electrical: See electrical configuration chart. 120 Volt; 208-240 Volt; 230 Volt and user configurable

Tank Temperature, as set by factory:

200°F (93°C) inside water tank (at sea level)

Water supply: (Optimal) 100-150TDS

All beverage equipment must use filtered water.

Weights and Capacities

Model	Height	Width	Depth	Water tank capacity	Empty Weight	Filled Weight	Shipping Weight	Shipping Dimensions	
CBS-1231 Brewer	27 3/4 in 700 mm	11 3/4 in 300 mm	20½ in 520 mm	3.3 gallon 12.4 L	29 lbs 13.2 kg	55 lbs 25.0 kg	41 lbs 18.6 kg	30" x 17" x 22" 76.2 x 43.2 x 55.9 cm	
CBS-1232 Brewer	27 3/4 in 700 mm	19 ¾ in 500 mm	20½ in 520 mm	6.0 gallon 22.4 L	47 lbs 21.3 kg	92 lbs 41.7 kg	55 lbs 25.0 kg	30" x 23" x 25" 76.2 x 58.4 x 63.5 cm	
Calibrated for 3.8 L/1.0 gal brew		Brew Basket 13" X 5"		Coffee Filter 13" X 5 or FETCO# F002"				1" legs standard 2.5" legs optional	

Rough-In Drawings

1201.00055.00 (CBS-1231) 1201.00054.00 (CBS-2132)

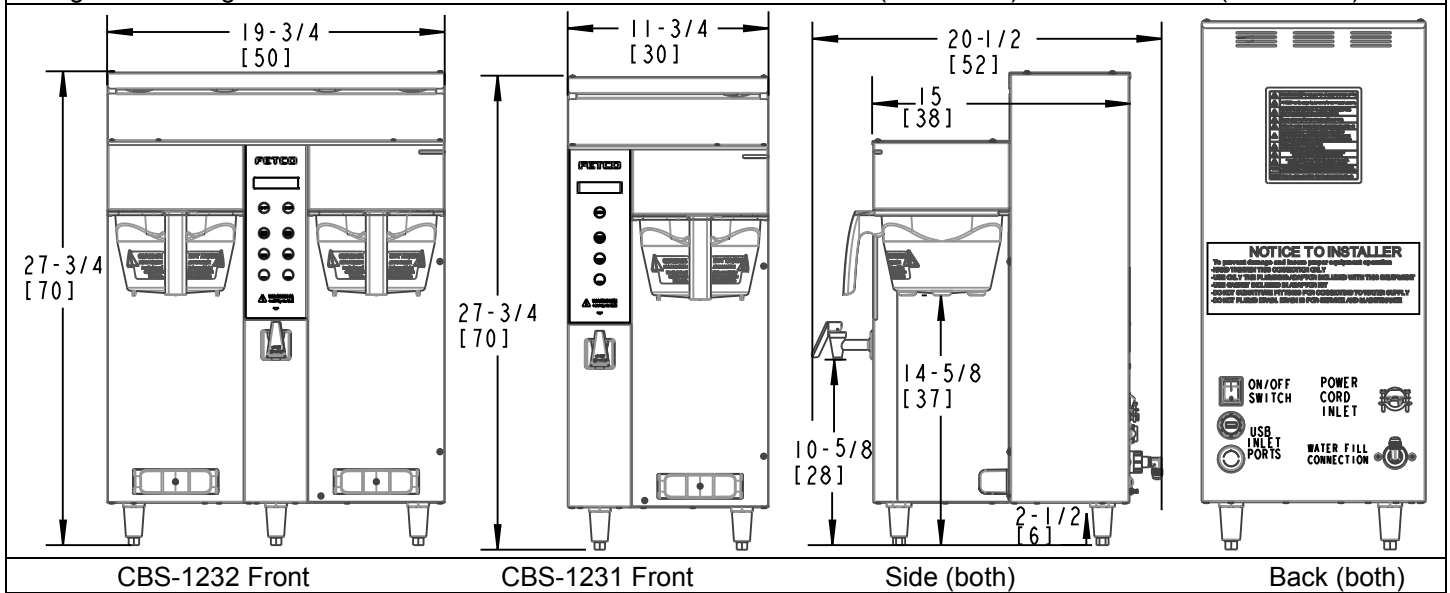

CBS-1232 Front

CBS-1231 Front

Side (both)

Back (both)

EXAMPLE: SKU E1231US-1X117-PM001

SKU NUMBER IDENTIFICATION KEY

Product Line	Level	Family	Region ID	Phase	Voltage Range	# Heaters	Individual Heater Wattage	Brew Basket	Hot Water Faucet	Bypass	Brew Basket Locks	Power Cord
E	1 2	3 1	U S	1	A	1	1 5	P	M	0	0	1
E=extractor	12=PLUS Series	31= single side 32= dual side	US =United States IN = International CE = CE NM = NOM	U = 1 or 3	A = 100-120 B = 200-240 C = 380-415 D = 440-480 X=120 or 240 Dual Voltage	1 2 3	1.5 1.7 2.3 3.0 4.0 5.0	P=plastic M=metal	M=manual A=automatic N=None	1=Yes 0=no	1=Yes 0=no	0=Terminal Block 1=NEMA 5-15P 2=NEMA 5-20P 3=NEMA 6-15P 4=NEMA 6-30P 5=CEE 7/7 Schuko 6=UK1-13P 7= AUSTRALIAN

Electrical and Output Specifications

CBS-1231PLUS Single 3.0-4.0 Liter Coffee Brewers Field configurable Domestic								
Electrical and Output Specifications Brewer has factory installed cord and plug & terminal block 50Hz or 60Hz								
SKU	Voltage	Heater Configuration	Wires	KW	Electrical Connection	Phase	Amp Draw	Brew-Volume per hour
E1231US-1X117-PM001	120	1 X 1.7 kW	2+G	1.7	NEMA 15-5P	1	14.7	3.9 gal/14.8 L
Domestic-Dual Voltage	208-240	2 X 1.7 kW	2+G	2.6-3.4	Terminal Block	1	12.8-14.7	5.8 gal/22 L

Electrical Specifications, Domestic Single brewer-single voltage 120 volt cord and plug single phase 50Hz or 60Hz

CBS-1231PLUS Single 3.0-4.0 Liter Coffee Brewers Domestic models								
Electrical and Output Specifications All brewers have factory installed cord and plug 50Hz or 60Hz								
SKU	Voltage	Heater Configuration	Wires	KW	Electrical Connection	Phase	Amp Draw	Brew-Volume per hour
E1231US-1A115-PM001	120	1 X 1.5 kW	2+G	1.5	NEMA 15-5P	1	13.0	4.0 gal/15.1 L
E1231US-1A123-PM002	120	1 X 2.3 kW	2+G	2.3	NEMA 5-20P	1	19.7	5.8 gal/22 L
E1231US-1A123-MM112	120	1 X 2.3 kW	2+G	2.3	NEMA 5-20P	1	19.7	5.8 gal/22 L

CBS-1231PLUS Single 3.0-4.0 Liter Coffee Brewers Field configurable International								
Electrical and Output Specifications Brewer has factory installed cord and plug & terminal block 50Hz or 60Hz								
SKU	Voltage	Heater Configuration	Wires	KW	Electrical Connection	Phase	Amp Draw	Brew-Volume per hour
E1231NM-1X123-PM002	120	1 X 2.3 kW	2+G	2.3	NEMA 5-20P	1	19.7	6.1 gal/23.2 L
Dual Voltage	208-240	2 X 2.3 kW	2+G	4.6	Terminal Block	1	17.1-19.7	7.6 gal/30 L

CBS-1231PLUS Single 3.0-4.0 Liter Coffee Brewers International models								
Electrical and Output Specifications All brewers have terminal block electrical utility connection 50Hz or 60Hz								
SKU	Voltage	Heater Configuration	Wires	KW	Electrical Connection	Phase	Amp Draw	Brew-Volume per hour
E1231NM-1A123-PM002	120	1 X 2.3 kW	2+G	2.3	NEMA 5-20P	1	19.7	5.8 gal/22 L
E1231NM-1B130-PM003	208-240	1 X 3.0 kW	2+G	2.3-3.0	NEMA 6-15P	1	11.3-13.0	7.9 gal/30.0 L
E1231IN-1B123-PM000	200-240	1 X 2.3 kW	2+G	1.6-2.3	Terminal Block	1	8.5-10.1	5.8 gal/22 L
E1231IN-1B130-PM000	200-240	1 X 3.0 kW	2+G	2.1-3.0	Terminal Block	1	10.9-13.0	7.7 gal/29.1 L

CBS-1232PLUS Dual 3.0-4.0 Liter Coffee Brewers Domestic models								
Electrical and Output Specifications All brewers have terminal block electrical utility connection 50Hz or 60Hz								
SKU	Voltage	Heater Configuration	Wires	KW	Electrical Connection	Phase	Amp Draw	Brew-Volume per hour
E1232US-1B223-PM000	208-240	2 X 2.3 kW	2+G	3.5-4.6	Terminal Block	1	17.1-19.7	11.0 gal/42.0 L
E1232US-1B230-MM110	208-240	2 X 3.0 kW	2+G	4.5-6.0	Terminal Block	1	22.2-25.5	14.3 gal/54 L
E1232US-1B230-PM000	208-240	2 X 3.0 kW	2+G	4.5-6.0	Terminal Block	1	22.2-25.5	14.3 gal/54 L

CBS-1232PLUS Dual 3.0-4.0 Liter Coffee Brewers International models								
Electrical and Output Specifications All brewers have terminal block electrical utility connection 50Hz or 60Hz								
SKU	Voltage	Heater Configuration	Wires	KW	Electrical Connection	Phase	Amp Draw	Brew-Volume per hour
E1232IN-1B223-PM000	200-240	2 X 2.3 kW	2+G	3.2-4.6	Terminal Block	1	16.5-19.7	12.2 gal/46.3L
E1232IN-1B230-PM000	200-240	2 X 3.0 kW	2+G	4.2-6.0	Terminal Block	1	21.3-25.5	15.8 gal/60 L
E1232NM-1B230-PM000	208-240	2 X 3.0 kW	2+G	4.5-6.0	Terminal Block	1	22.2-25.5	15.8 gal/60 L
E1232KS-1B230-PM000	208-240	2 X 3.0 kW	2+G	4.5-6.0	Terminal Block	1	22.2-25.5	15.8 gal/60 L

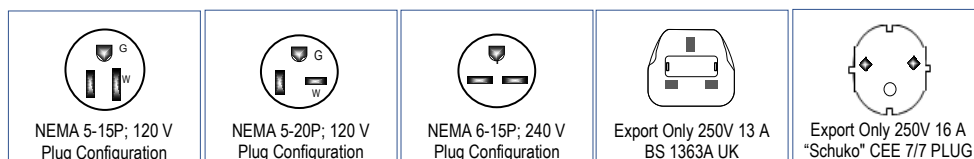

Starting The Brew

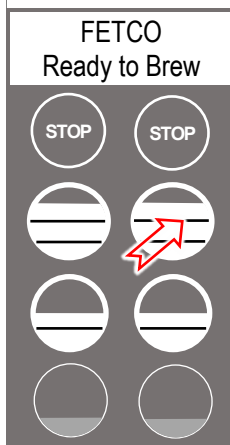

1. Turn the power switch "ON". (Twin Shown)
2. Prepare a brew basket with the correct size filter and appropriate amount of coffee.
3. Slide the brew basket completely into the rails.
4. Place a clean, empty, and preheated dispenser under the brew basket.
5. Select a batch & hold the corresponding BREW button in for 1 second to start
6. -STOP button will illuminate,
-Countdown time will display,
-Selected BREW button will flash to indicate brew is in progress.
-All other BREW buttons for that brew head will extinguish.
7. When the brew cycle is finished, STOP button will extinguish and the BREW button will continue to flash for the amount of time programmed into the DRIP DELAY setting. This indicates that coffee may still be dripping from the brew basket
For safety- do not remove brew basket until drip-out is complete.

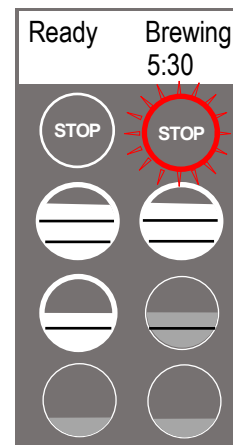

Twin Brewer ready to brew. Example shown: Pressing top right brew position

Brewing-see #6 above

The Brew Sequence

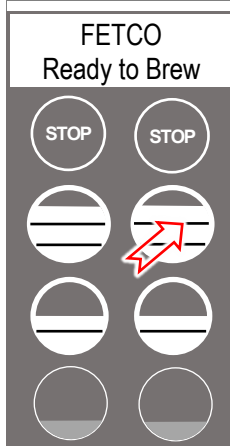

First screen shows top right brew position being activated, (as above)...

Left side is in "READY-MODE" during brew, but left side buttons can be accessed for brewing

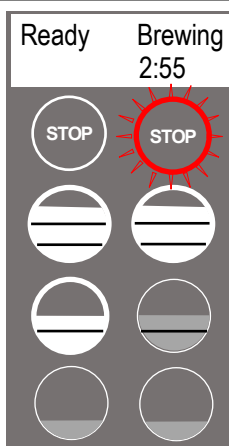

STOP brew lamp activates and top right button will pulsate.

All other buttons on the right side extinguish.

Count down timer activates beginning 5:30 for Batch 1
5:00 for Batch 2

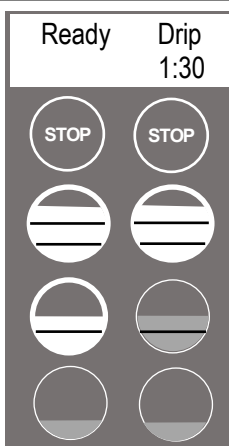

The brewing cycle completes in four minutes. Stop button extinguishes and drip out starts at 1:30 minutes.

Do not remove brew basket during this segment.

Brewer returns to "ready to brew" (screen one) after drip out completes

Enter Programming

Screens shown are for twin brewer. Single brewer will not have menu A4-A6.

There are seven menu groups-A-G . See the following pages for the batch parameter definitions and all settings for the brewer

TO ENTER PROGRAMMING

- 1-Turn brewer "OFF" from power switch
 - 2-Turn power switch to "ON"
- ...Screen will initialize and then display digital process notifications
- 3-After Initialization-Red "STOP" Lamp turns on
 - 4-Quickly press "STOP" button.

When brewer is In PROGRAMMING MODE
-the screen will display:

BATCH PRG|
|A (or B-H) |

-Illuminated LED indicates active keypad positions

See the following pages for batch parameter definitions and all settings for the brewer

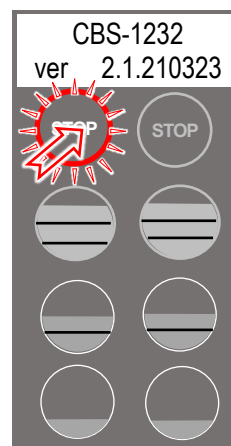
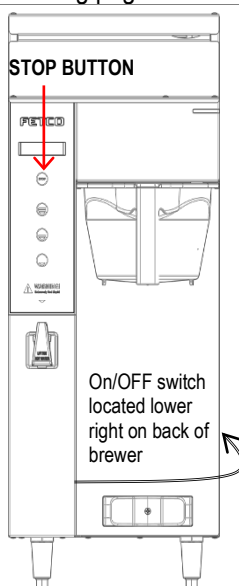

Turn power OFF
Turn power ON
Wait for red LED
And quickly press STOP
button on front touch pane

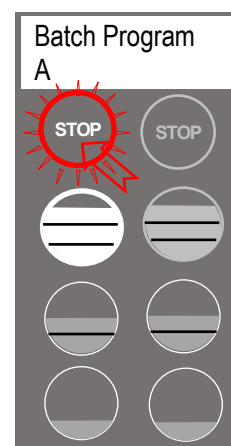

First screen will display for PROGRAMMING-A
Scroll through main menu topics by pressing "STOP" button.

Note: Only the left side buttons of a two sided brewer are used for programming

Programing Menu Layout

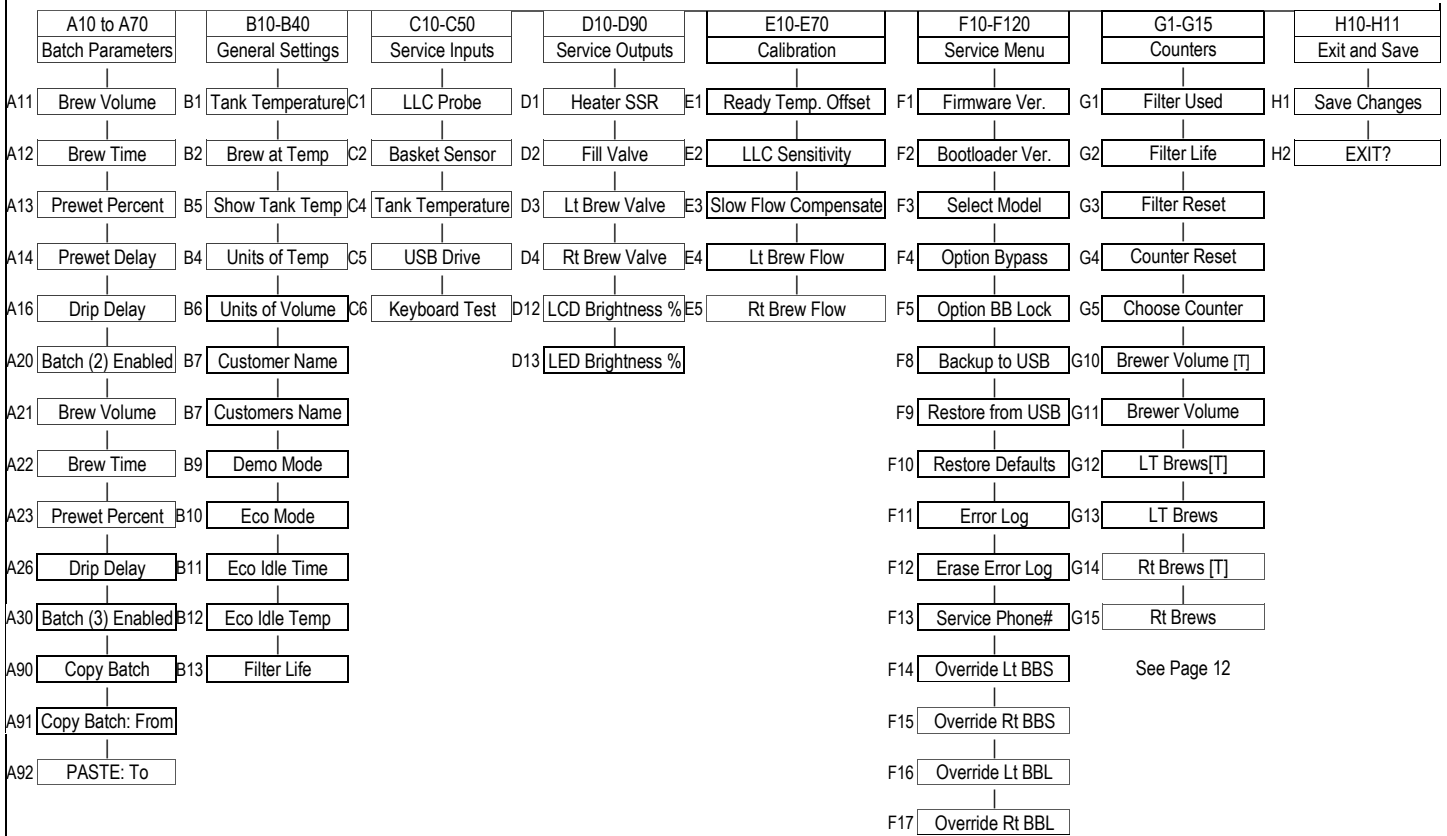

Left and Right top and middle batches are permanent SEE BOX on the following page for all "A" menus

The "A" menu is the most accessed menu. It is for programming the batch volumes, brewing parameters, enabling or disabling brew buttons. The "A" menu moves through the six positions (CBS-1232+) or three positions (CBS-1231+) by entering the menu and pressing the left stop button. (only the left side is active for programming the CBS-1232+)

The A menus [A1-3 or A1-6] correspond to batch buttons [3 or 6] on the touch panel

Access the A menus to PROGRAM & make changes to individual menu recipes. Menu settings can be copied
Menu positions A1 and A4 [top position] are permanent. Menus A2, A3, A5, A6 can be removed by operator if desired

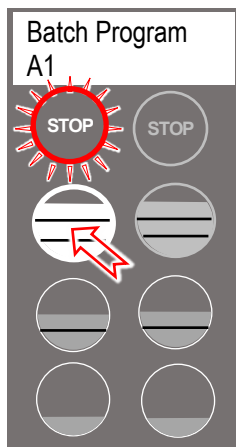

From A PRG screen
Press button 1 to go into to the A menu access screens. Continue pressing button #1 to enter programming for A1

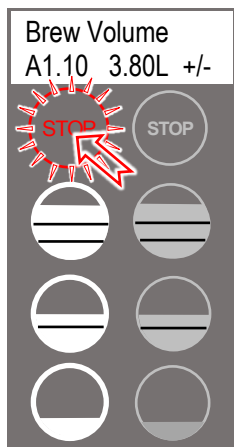

From A11 screen
Press **STOP** to scroll to A20. (A1&A4 are permanent)

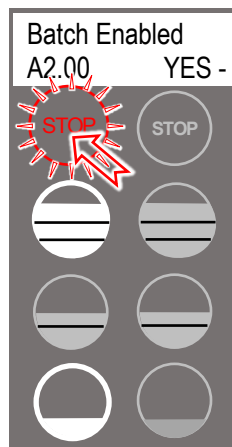

From A20 screen
Press STOP to scroll through the remaining (3 or 6) "A" menus. Make any changes as required

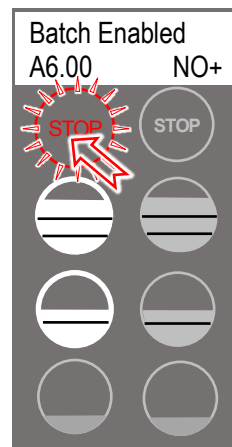

From A60 screen
Scroll out to remaining A10-to-A70 programming keys. See SAVE & EXIT in previous table

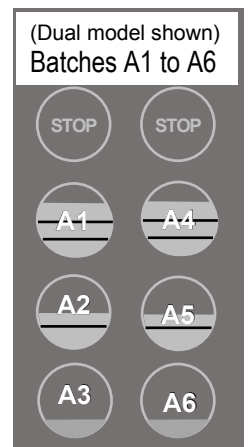

For single and twin
Position of batch buttons for CBS-1232+

The CBS-1231+ single position brewer has one row of buttons

A Program Menu Features: Batch Parameters

The settings below are shown for the top batch on a single brewer top left button on a twin brewer. See how to access all A menus on the previous page. Below are the brew settings for default A1 & A2 batches

POSITION	Program Items	Factory set Default	Programming Range	Increments	Notes
A1.10	Batch Volume	3.8 L 1 gal	0.95 to 4.75L 0.25 to 1.25 gal	0.05L 0.01G	Unit software is in L; converts to gallon
A1.20	Brew Time	4:00 minutes	2:00 – 12:00	0.30	Default total brew time is 5:30 minutes
A1.30	Prewet Perc.	0%	0.00 – 25.0%	1%	Percentage of total brew volume
A1.40	Prewet Delay (Pause after prewet completes)	0% [1:00 Min]	[0:10 – 5:00]	1:00 min	The time between prewetting and start of brew cycle. This feature appears ONLY if Prewet >0:00
A1.60 This is a Safety Feature	Drip Delay	1:30 mm:ss	0:30 – 6:00 Min.		Time that brew basket remains locked during final drip-out →Drip delay remains “ON” for 1:30 minutes if STOP is pressed during brew†
A2.00	BATCH ENABLED	YES (Active)	Middle and Bottom batches A2,3,5,6	Batch on or off	Batches may be individually enabled, rewritten or deactivated
A2.10	Batch Volume	2.90L 0.75gal	0.95 to 4.75L 0.25 to 1.25 gal	0.05L 0.01G	Unit software is in L; converts to gallon
A2.20	Brew Time	3:30 minutes	2:00 – 12:00	0.30	Default total brew time is 5:30 minutes
A2.30	Prewet Perc.	0%	0.00 – 25.0%	1%	Percentage of total brew volume
A2.40	Prewet Delay (Brew pause after prewet completes)	0% [1:00 Min]	[0:10 – 5:00]	1:00 min	The time between prewetting and start of brew cycle. This feature appears ONLY if Prewet >0:00
A2.60 Safety Feature	Drip Delay	1:30 mm:ss	0:30 – 6:00 Min.		Time that brew basket remains locked during final drip-out
A30	Batch Enabled A30 YES - NO +	NO-inactive (defaults to recipe A20 if activated)	Middle and Bottom batches A2,A3	Batch on or off	Batches may be individually enabled, rewritten or deactivated
Batch Copy	Copy From Batch	A90	A90 1 (1-6)		
	Copy To Batch?	A91	A91.1 (1-6)		

Single Topmost Batch cannot be disabled. TWIN Topmost Batch LEFT & RIGHT cannot be disabled.
Middle and bottom batches may be disabled for single and twin brewer (CBS-1231 and CBS-1232)
† DRIP DELAY will not activate when STOP is pressed within 5 seconds of starting a brew time

<p>RECIPE Location map</p> <p>Viewing and changing settings for the brew recipes is from the “A” screens with the controls in PROGRAMMING.</p> <p>The uppermost button positions are permanent and will not display programming step A_0. The table above shows in position A20 that a button position can be made active or inactive. Position A1 does not display this step</p>	<p>Single Side Models CBS-1231 Plus</p>	<p>←DISPLAY→</p> <p>←STOP→</p> <p>←BATCH A1→ (permanent)</p> <p>←BATCH A2→ (enabled by factory)</p> <p>←BATCH A3→ (disabled by factory)</p>	<p>Dual Side Models CBS-1232 Plus</p>	<p>←DISPLAY</p> <p>←STOP</p> <p>←BATCH A4→ (permanent)</p> <p>←BATCH A5→ (enabled by factory)</p> <p>←BATCH A6→ (disabled by factory)</p>
---	---	---	---	---

B General		Brewer Operation Control Settings, Adjust Brew Flow Rate			
POSITION	Program Items	Factory set Default	Programming Range	Increments	Notes
B1	Tank Temp.	200°F-or-93° C NOTE: Equipment is Fahrenheit by default	77° to 97°C 170°F to 207°F	0.5°C 1.0°F	Chart to correct for high altitude below
B2	Brew at Temp.	“YES”	ON/OFF	YES/NO	SEE NOTE BELOW
B4	Show Tank Temperature	YES	YES/NO		To display HW tank temperature on screen
B5	Units of Measure TEMPERATURE	° Fahrenheit	Fahrenheit/Celsius	C/F	NOTE: Overwrites user settings (see page 9)
B6	Units of Measure VOLUME	Liters	Gallons/Liters/Ounces	L/Gal/Oz	NOTE: Overwrites user settings (see page 9)
B7	Customer Name	Off	NO or YES		For name on screen
B7	Customer Name	(only if above is “ON)	Scroll with batch keys	A-Z;a-z;0-9	16 characters total
B9	Demo Mode	DEMO ON/OFF			Demonstrates the controls for training. Disables all components in demo mode
B10	Eco Mode	On	ON/OFF	YES/NO	If Selected: Lowers hot water tank temperature after preset time of inactivity
B11	Eco Idle Time	1Hr	1-6 hours	1 hour	Time of inactivity to go into ECO Mode
B12	Eco Idle Temp	170°F	158-176°F	1 degree	Temperature that hot water tank is lowered to when in ECO Mode
B13	Filter Life	OFF	ON/OFF	YES/NO	Water filter life is accessed in G-Counters. This is user set and will display indicator to change water filter

BREW AT TEMPERATURE DEFINITIONS

<p>DEFAULT: BREW AT TEMP: “ON”</p> <p>(FACTORY DEFAULT FOR BREWER)</p> <p>“BREW at TEMP:</p> <p>-Batch will not start if tank temperature is below set point.</p> <p>-Display will show “HEATING” and hot water tank temperature</p> <p>The “BREW START” entry buttons will not illuminate until the hot water tank reaches the selected temperature.</p> <p>Controls allow both sides of dual brewer to operate if one side has an ongoing brew started and the second side brew is selected.</p> <p>Notifications shown on screen:</p> <p>TEXT: HEATING→ Tank above 87°C/189°F-will allow brew at low temperature. Coffee flavor may be affected</p> <p>TEXT: L. HEAT→ Tank above 76°C/169°F-will allow brew at low temperature. Coffee flavor will be noticeably affected</p> <p>USER SELECTABLE OPTION: BREW AT TEMP: OFF (Not recommended) Unit will operate at cold temperature</p> <p>Allows brewing at any temperature above 77°C/170°F</p> <p>Below 70°C/170°F The red colored ready lights switch turn off</p>	<p>Hot water tank not at brew temp setpoint.</p> <p>Tank temp→</p> <p>STOP is not lit →</p> <p>BREW START buttons not lit. and are disabled.</p> <p>When hot water tank temperature is at setpoint. Buttons will illuminate and “READY” will be displayed</p>	
--	---	--

[ft]	[m]	Suggested Setting[°F]	Boiling point[°F]	Suggested Setting[°C]	Boiling point [°C]
0	0	205	212.0	96	100.0
500	152	205	211.0	96	99.5
1000	305	200	210.1	93	98.9
2000	610	200	208.1	93	97.8
2500	762	200	207.2	93	97.3
3000	914	200	206.2	93	96.8
3500	1067	197	205.3	92	96.3
4000	1219	195	204.3	91	95.7
4500	1372	194	203.4	90	95.2
5000	1524	194	202.4	90	94.7
5500	1676	193	201.5	89	94.2
6000	1829	192	200.6	89	93.6
6500	1981	191	199.6	88	93.1
7000	2134	190	198.7	87	92.6
7500	2286	188	197.8	86	92.1
8000	2438	187	196.9	86	91.6
8500	2591	185	196.0	85	91.1



C Service Inputs		Brewer Sensors and Keypad			
POSITION	Program Items	Factory set Default	Programming Range	Increments	Notes
C1	LLC Probe continuity	Direct read	Reading of tank water resistance in TDS	≈850- LOW ≈1600-HIGH	Nominal values
C2	Brew Basket Sensor	L-YES R-YES	YES or NO		
C3	Tank Temperature	Direct read	Hot water tank temperature		Actual values
C4	USB Drive	NO	(not in use)		
C6	Keyboard Test	Calibrate	Checks buttons under membrane cover	YES/NO	Follow directions on the touch screen

D Service Outputs		Test Valves and Heaters; Set screen brightness			
POSITION	Program Items	Factory set Default	Programming Range	Increments	Notes
D1	Heater SSR Test	Press button 2 to test (button 1 stops test)	Activates heater Default is 10 sec..	Toggle +/- OFF or ON	Energizes Heater(s) WARNING! Service use only.
D2	Fill Valve Test	Press button 2 to test (button 1 stops test)	Activates valve Default is 10 sec.	Toggle +/- OFF or ON	Press To Test
D3	LT (left) Brew Valve Test (on CBS-1232 only)	(Press to test)	Activates valve Default is 10 sec.	Toggle +/- OFF or ON	Runs valve to verify flow. NOTE: Have container under brew basket.
D4	RT (right) Brew Valve Test	(Press to test)	Activates valve Default is 10 sec.	Toggle +/- OFF or ON	Runs valve to verify flow. NOTE: Have container under brew basket.
Single series displays right side only Left Valve display is only for twin side brewer.					
D12	LCD Brightness	Brightness=90%	20-100%	5%	Adjust LCD screen brightness only-Not for LEDs under buttons
D13	LED Brightness	Brightness=60%	20-100%	5%	Adjust LED button brightness only-Not for the screen display LCD



E Calibration		Brewer Sensors and Keypad			
POSITION	Program Items	Factory set Default	Programming Range	Increments	Notes
E1	Ready Temp. Offset	-3°F -2°C	-2° to -9°F -1° to -5° C	1°F 1°C	Compensates output to measured temperature
E2	LLC Sensitivity	NORMAL ("NORMAL" for most water)	HIGH (Biased for reverse osmosis water or very pure water)	NORMAL HIGH	Liquid level control sensitivity. High, 1300Ω is for reverse osmosis water or very pure water.
E3	Slow flow rate from supply	ON	OFF/ON	Toggle +/- YES or NO	Trims fill system for low supply or Flojet use
E4	LT Brew valve flow rate:	1.80L 0.47G 61oz	1.05-1.60Liter 0.39-0.55G 50-71 fl.ounces	0.05L 0.01G 1 oz	Adjusts flow rate
E5	RT Brew valve flow rate:	1.80L 0.47G 61oz	1.05-1.60Liter 0.39-0.55G 50-71 fl.ounces	0.05L 0.01G 1 oz	Adjusts flow rate
E6*	LT Bypass valve flow rate:	1.30 liters/minute (0.36 gallon/minute) (46 ounces/minute)	1.10-1.65Liter 0.28-0.42G 37-54 fl.ounces	0.05L 0.01G 1 oz.	Adjusts flow rate
E7*	RT Bypass valve flow rate:	1.30 liters/minute (0.36 gallon/minute) (46 ounces/minute)	1.10-1.65Liter 0.28-0.42G 37-54 fl.ounces	0.05L 0.01G 1 oz.	Adjusts flow rate

*Active if bypass is installed and activated on equipment

Use this formula to compensate for minor discrepancies in actual volume versus programmed volume.

See "PROGRAM" [E4](#) & [E5](#) For valve settings and calibration. Factory set brew valve flow rates are in liter/min

$$\frac{\text{ACTUAL VOLUME}}{\text{PROGRAMMED VOLUME}} \times \text{CURRENT SETTING} = \text{NEW SETTING}$$

Use the formula above to determine the correct setting

Default Brew Valve Flow Rate—CBS-1230 Brewers

<u>CBS-1230</u>	<u>L/minute</u>	<u>Range</u>
Left Brew Valve FR	1.80	1.50 L to 2.10 L
Right Brew Valve FR	1.80	1.50 L to 2.10 L

Set FR **lower** to **increase** volume,
Set FR **higher** to **decrease** volume



F Service Menu		Software & Code View and Settings			
POSITION	Program Items	Factory set Default	Programming Range	Increments	Notes
F1	Display Firmware	2.2.210720			Displays current version [6/2020]
F2	Display Bootloader	2.0.210317			Displays current version [6/2020]
F3	Select Model	CBS-1231 or 1232 Will need reboot	Scroll to brewer model Save & Exit	CBS-1221 CBS-1241, CBS-1242 CBS-1241, CBS-1242 CBS-1251, CBS-1252 CBS-1261, CBS-1262 MBS-1241, MBS-1251	NOTE: Overwrites all user settings (See below)
F4	Option Bypass	Yes	NO or YES		Turns on bypass
F5	Option BB Lock	NO	NO or YES		Apply to future upgrade kit
F8	Backup to USB	NO	Follow prompts	Saves settings	Insert blank USB
F9	Restore From USB		Applies settings from USB		Insert USB Will need reboot
F10	Restore Defaults	NO	NO/YES		Reset to factory
When selecting F10-RESTORE DEFAULTS, save and exit programming (page 13). Brewer returns to factory defaults for your model and deletes all user inputted changes.					
F11	Error Log	Lists up to six codes, in order	1: ; 2: ;3:;4: ;5: ;6: 1=Newest/6=Oldest LAST six errors only	Newest=first Oldest=last	See Error Code Chart for references
F12	Erase Error Log	NO +		Toggle +/- YES or NO	FACTORY USE ONLY. DO NOT RESET
F13	Service Phone #				Set phone for display
F14	Override Lt BBS	NO	NO/YES	Toggle +/- YES or NO	Disables brew basket sensor (CBS-1242 only)
F15	Override Rt BBS	NO	NO/YES	Toggle +/- YES or NO	Disables brew basket sensor
F16	Override Lt BBL	NO	NO/YES	Toggle +/- YES or NO	Disables brew basket lock (CBS-1242 only)
F17	Override Rt BBL	NO	NO/YES	Toggle +/- YES or NO	Disables brew basket lock



F Error Codes

DO NOT CLEAR ERROR CODES UNTIL ERROR IS IDENTIFIED AND CORRECTED

→Contact factory or specialized personnel for error codes

Code	Description	Possible Cause	Corrective Action
001	Software error-error on start up or corrupted software	Improper start-up or shutdown	Restart , if still fault: reload software
002	Internal flash corrupted internal data memory malfunction	Error found in cyclic redundancy check CRC	Restart , if still fault: reload software If not corrected :replace board
050	Short-circuit in temperature probe	Probe failure.	Replace probe.
051	Open temperature probe.	Bad probe connection, or probe failure.	Check all connections. Replace probe if necessary.
100	Initial Fill Error. Initial fill time took longer than expected after powering up.	Water supply flow rate is too low.	Watch for short potting during brew cycle. Investigate cause of low flow rate. (Clogged water filter...)
101	Error on refill-. Tank did not refill within expected time.	Water supply flow rate is too low.	Watch for short potting during brew cycle. Investigate cause of low flow rate. (Clogged water filter...)
200	Heating flatline-Tank is boiling	Heater is on, temperature is not rising/dropping	High elevation correction. Bad heaters or temperature probe or position
201	Heater open, high limit thermostat, or Solid State Relay (SSR) fault	Failure of heating element, SSR, high limit or low voltage	Check and replace heating elements, SSRs, high limit devices if necessary.
202	Heater Shorted or Stuck SSR	Heater is off and heating SSR is stuck "ON"	Check that ohms range of heater are between 10-80Ω; replace if not. SSR may be stuck in ON mode-replace SSR.
255	Keyboard [HID] error	Usually from longer than 10 sec contact. Or faulty reassembly after service	Restart , if still fault: reload software. If mechanical: replace module
NO BSKT		Brew basket must be in place This is a SAFETY FEATURE	Insert brew basket into brewer rails to enable brewer
<u>Insert Brew Basket</u>			

G Counters Brewer Usage, Water Filter Usage, and Statistics

ROLE: [LT]=Permanent total for lifetime of machine [R]=operator resettable [User]=Input needed from operator

Position	Counter	Program items	Role	Information	Increments	Notes
----------	---------	---------------	------	-------------	------------	-------

G1-G3 are for water filter maintenance. Filter Life readings (G1, G2, G3) must be activated in B13 GENERAL if they are not visible and the equipment has a water filter. All beverage equipment must use filtered water and filter cartridges must be monitored for quality

G1	A, S, B	Filter Used	[User]	0G	Gallons/Liters	Amount of water passed through external water filter. For filter life
G2	A, S, B	Filter Life	[User]	2,625Gal 10,000Liters	25 gal 100 L	Upload published life of filter
G3	A, S, B	Filter Reset	[User]	NO	Toggle +/- ,Y or N	Reset when replacing external water filter
G4	A, S, B	Counter Reset	[User]	NO	Toggle +/- ,Y or N	Resets all resettable counters to zero
G5	A, S, B	Choose Counter		Factory set to BASIC	Basic= B Advanced= A Statistical= S	Stored brewer component activity.. See column 2, Counters , to identify where counters are located.

G10-G15 Number of brews and volumes handled. Available in BASIC counter only (G5)

G10	B	Brewer Volume	[LT]	Dispensed volume	Gallons/Liters	Total of brews and hot water dispensed
G11	B	Brewer Volume	[R]			
G12	B	Lt Brews	[LT]	Left side brew total CBS-1232	Count	Total brews-Left side (CBS-1232 only)
G13	B	Lt Brews	[R]			
G14	B	Rt Brews	[LT]	Right side brew total CBS-1231&CBS-1232	Count	Total brews-Right side CBS-1231&CBS-1232
G15	B	Rt Brews	[R]			

G20-G55 component use cycles and volumes handled. Available in ADVANCED counter only (G5)

G20	A	Fill Cycles	[LT]	Hot water tank refill cycles	Count	Cycles of hot water tank refill
G21	A	Fill Cycles	[R]			
G22	A	Fill Volume	[LT]	Total volume of water for all brews	Gallons/Liters	Quantity of water for brews
G23	A	Fill Volume	[R]			
G24	A	Lt Brew Cycles	[LT]	Left brew valve operation on/off	Count	Totalized cycles of valve operation (CBS-1232 only)
G25	A	Lt Brew Cycles	[R]			
G26	A	Lt Brew Volume	[LT]	Left brew valve flow through volume	Gallons/Liters	Totalized volume through left valve (CBS-1232 only)
G27	A	Lt Brew Volume	[R]			
G28	A	Rt Brew Cycles	[LT]	Right brew valve operation on/off	Count	Totalized cycles of valve operation CBS-1231&CBS-1232
G29	A	Rt Brew Cycles	[R]			
G30	A	Rt Brew Volume	[LT]	Right brew valve flow through volume	Gallons/Liters	Totalized volume through right valve CBS-1231&CBS-1232
G31	A	Rt Brew Volume	[R]			
G32	A	Lt Bypass Cycles	[LT]	Left bypass valve operation on/off	Count	Totalized cycles of valve operation (CBS-1232 only)
G33	A	Lt Bypass Cycles	[R]			
G34	A	Lt Bypass Volume	[LT]	Left bypass valve flow through volume	Gallons/Liters	Totalized volume through left valve (CBS-1232 only)
G35	A	Lt Bypass Volume	[R]			
G36	A	Rt Bypass Cycles	[LT]	Count	Count	Totalized cycles of valve operation CBS-1231&CBS-1232
G37	A	Rt Bypass Cycles	[R]			
G38	A	Rt Bypass Volume	[LT]	Right bypass valve flow through volume	Gallons/Liters	Totalized volume through right valve CBS-1231&CBS-1232
G39	A	Rt Bypass Volume	[R]			
G52	A	Heater Cycles	[LT]	ON/OFF switching for heating elements	Count	Totalized cycles of heater switching
G53	A	Heater Cycles	[R]			
G54	A	Heater On Time	[LT]	Total ON time for heating element	Hour	Totalized heater ON time in hours
G55	A	Heater On Time	[R]			

G80-G91 See illustration below for batch button positions Available in STATISTICAL counter only (G5)

G80	S	Batch 10 Cycles	[LT]	Menu button selection and activation count	Count	Total brews-left side top button (CBS-1232 only)
G81	S	Batch 10 Cycles	[R]			
G82	S	Batch 20 Cycles	[LT]	Menu button selection and activation count	Count	Total brews-left side middle button (CBS-1232 only)
G83	S	Batch 20 Cycles	[R]			
G84	S	Batch 30 Cycles	[LT]	Menu button selection and activation count	Count	Total brews-left side bottom button (CBS-1232 only)
G85	S	Batch 30 Cycles	[R]			
G86	S	Batch 40 Cycles	[LT]	Menu button selection and activation count	Count	Total brews-right side top button CBS-1231&CBS-1232
G87	S	Batch 40 Cycles	[R]			
G88	S	Batch 50 Cycles	[LT]	Menu button selection and activation count	Count	Total brews-right side middle button CBS-1231&CBS-1232
G89	S	Batch 50 Cycles	[R]			
G90	S	Batch 60 Cycles	[LT]	Menu button selection and activation count	Count	Total brews-right side bottom button CBS-1231&CBS-1232
G91	S	Batch 60 Cycles	[R]			



H Save & Exit

Saving changes and exiting PROGRAMMING

The brewer will only save changes from the "H" menu. **DO NOT** reboot brewer or toggle ON/OFF-exit as below.

TO EXIT PROGRAMMING & HOW TO SAVE CONTROL SETTING CHANGES

HOW TO SAVE CHANGES AND EXIT-*The brewer is in PROGRAMMING mode.*

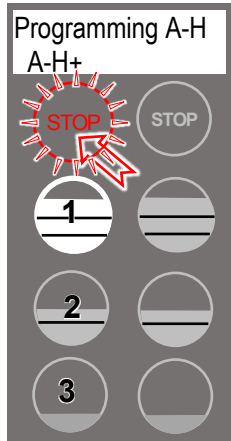

From any screen-
Press STOP button
until the EXIT ("H")
screen appears

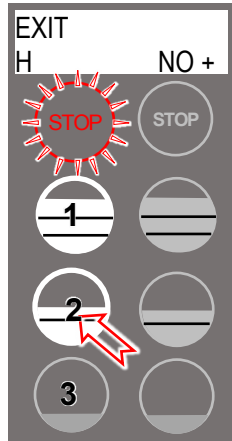

From the "H" screen
Press button **2** to
toggle to the EXIT-
YES screen

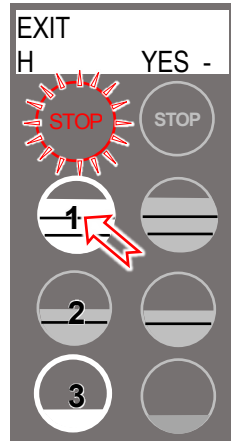

From EXIT screen
Press button **1** to
toggle to the SAVE
screen

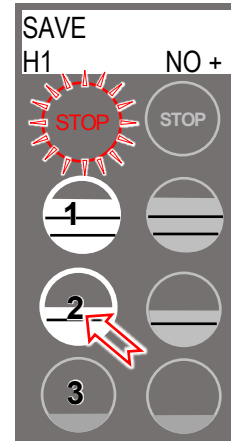

From SAVE screen
Press button **2**, to
toggle to the SAVE-
YES screen

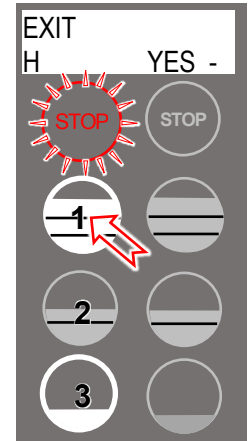

To SAVE and EXIT
Press button **1** to
SAVE your changes
and EXIT

NOTE: User Settings will be erased and overwritten to factory default settings by the following five programming changes

- 1) When setting or changing units of display for the tank temperature (F Fahrenheit or C Celsius). **(SETTING B4)**
- 2) When setting or changing units of display for the volume (L L, G gallons). **(SETTING B5)**
- 3) When setting brewer model →The software sets equipment to brewer defaults **(SETTING F3)**
- 4) When loading from USB (Reprograms settings) **(SETTING F9)**
- 5) When restoring defaults (Reloads to defaults) **(SETTING E10)**

Operator Training

Review the operating procedures with whoever will be using the brewer.

Pay particular attention to the following areas:

1. Always pre-heat the dispensers before the first use of each day by filling them halfway with hot water and letting them stand for at least 5 minutes.
2. Do not remove the brew basket from a coffee brewer until it has stopped dripping.
3. Make sure the dispenser is empty before brewing into it.
4. Show how to attach covers, close, and or secure the dispensers for transporting.
5. Show the location and operation of the water shut off valve as well as the circuit breaker for the brewer.
6. Steam from the tank will form condensation in the vent tubes. This condensation will drip into and then out of the brew baskets. Up to 1/4 cup/118cc discharging overnight is possible. Place an appropriate container under each brew basket when not in use.
7. We recommend leaving the power to the brewer on overnight. The water tank is well insulated and very little electricity is used to keep the tank hot. Leaving the brewer in the "ON" position will also avoid delays at the beginning of shifts for the brewer to reach operating temperature.

Cleaning & Maintenance

After Each Brew:

1. Dispose of grounds and rinse brew basket.
2. Never strike a brew basket or hit it against a hard surface.
This will damage the brew cone, and may damage the brew basket support rails
3. Rinse dispensers before reuse.

Every Day:

1. Wash brew basket with hot suds water.
2. Pull CSD from the spray head, it is magnetically attached. Use gloves or a heavy towel. → Wash off any film and reattach. Use vinegar if limescale filming is present.
3. Clean dispensers with hot suds water and a brush, rinse and air dry.
4. Use only a soft cloth and hot suds on the outside to avoid scratches. Never use abrasives that will scratch surface.

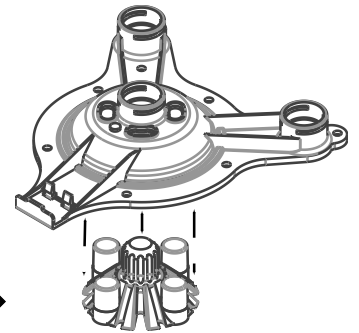

Weekly

1. Use a commercial coffee dispenser cleaner such as URNEX™, TABZ™, DIP-IT™ or Squeak 'n Clean™.
2. Carefully Follow the instructions supplied with the cleaning product
3. Never use spray cleaners, solvent, solvent based cleaner or petroleum based polish anywhere on dispensers

Warning

1. Turn off power before any cleaning procedure, including wiping the exterior for appearance reasons.
2. Dry the exterior, especially the face panel, before turning on power.
3. Do not apply any type of spray cleaner on the face panel of this equipment.
4. Never use solvent or solvent-based cleaner or petroleum based polish anywhere on this equipment.
5. Dry the face of the touch pad before turning on power
6. Do not electrically energize this equipment or attempt operation without all covers in place and all screws fastened.
7. Unplug machine before disassembly or servicing.

Safety Notes

1. Professional installation is required. This appliance is manufactured only for commercial use
2. Operational requirements and maintenance for commercial cooking appliances differ from household appliances.
3. Operators must be trained for this equipment and must understand the use, maintenance and hazards.
4. Access to the service area is restricted to persons having safety/hygiene knowledge and practical experience of the coffee brewer. This appliance must be installed in locations where it can be overseen by adult trained personnel.
5. Do not attempt to move hot beverage equipment once it is filled. Drain equipment before moving.
6. FETCO commercial coffee brewers prepare large amounts of coffee or tea in a single batch using very hot water
7. Commercial coffee brewers provide very hot water from the spray head, brew basket and faucet when it is pulled.
8. Coffee brewers may continue to dispense very hot water from the mechanically operated faucet after the electronic touchpad is completely disabled by turning off the power switch on the lower back of the unit or unplugging the unit.
9. For safety, the brewer control locks the brew basket for 6.0 minutes after starting the brew.
10. Never attempt to defeat the factory set (default) time that the brew basket is locked for safety from start of brew.

Keep these instructions for training and future reference.

General:

1. If not installed correctly by qualified personnel, the brewer will not operate properly, and damage may result.
2. Utilize only qualified beverage equipment service technicians for service and installation.
3. Always have an empty dispenser under spray head of all coffee brewing equipment-including when at idle
4. Damages resulting from improper installation are not covered by the warranty and will void the warranty.
Below are the key points to consider before installation:

Electrical:

1. All CBS_Series brewers require **an electrical ground wire**. Installation without grounding is dangerous.
2. Note Equipotentiality Terminal, if present, (To identify the terminals which, when connected together, bring the various parts of equipment or of a system to the same potential, not necessarily being the earth (ground) potential, e.g. for local bonding.)
3. Verify voltages, polarity, circuits, and circuit breaker access before attaching equipment.
4. Brewers in this series wire differently in regard to a neutral wire. Review the wire diagrams.
5. The electrical diagram is located in the User's Guide and online at www.fetco.com.
6. Make sure of the tight grounding of the equipment and use the external ground bolt.
7. The installation must comply with applicable federal, state, and local codes having jurisdiction at your location. Check with your local inspectors to determine what codes will apply.

→See wiring diagrams on pages 27 to 29 for connections



Plumbing:

1. North America: All installations must comply with applicable federal, state, or local plumbing codes.
2. All Others: The water and waste piping and connections shall comply with the International Plumbing Code, International Code Council (ICC), or to the Uniform Plumbing Code (IAPMO).
3. Install a backflow prevention device. Most municipalities require a recognized backflow preventer
Usable on all hot beverage and cold beverage equipment is a WATTS® SD-2 or SD-3.
WATTS spring loaded double check valve models are accepted by most zoning authorities.
→The check valve should be as close to the water supply inlet of the beverage equipment as possible
4. All beverage equipment must use a water filter. A finishing carbon filter is preferred
5. Install the filter unit after a water shutoff valve and in a position to facilitate filter replacement.
6. The water line and newly installed filter cartridge must be flushed thoroughly prior to connecting it to the brewer to prevent debris from contaminating the machine
7. Verify that the water line will provide a flow rate of at least 1½gpm/(5.7lpm) per minute and the water pressure is between 20-75 psig (138-517kPa) before making any connections
8. Only use the supplied factory fitting to attach water supply line to brewer (shipped in brew basket)
9. The supplied fitting is a 3/8" flare/compression fitting for 1/4" supply line. Other adaptors may be substituted.
10. Hand tighten the factory fitting when connecting the stub on the brewer. This will reduce stress on the internal connections and reduce the possibility of leaks developing after the install has been completed

Tank Drain

The water tank must be drained before maintenance procedures, and when the unit is to be relocated or shipped. Drain is for service use only and must not be permanently connected. NOTE: Never plumb a water line to the drain.

1. Disconnect power and water to unit. DANGER: Ensure that all utility connections to the brewer are broken.
2. Move the unit near a sink or obtain a container large enough to hold four gallons of water.
→Note: The hot water tank of the CBS-1231 may hold up to 3.3 gallons; the CBS-1232 up to 6.0 gallons.
3. Remove the front panel and tank cover and allow the tank to cool to a safe temperature
4. The tank drain line and clamp are located inside-under the hot water tank. Pinch the drain line clamp to close
5. Locate the fill valve against the back wall, using pliers, loosen the hose clamp and move it back over the tube.
→Note Do not loosen the hose clamp to the bottom of the hot water tank
6. Crimp the tube an inch or two away from the drain plug to prevent water from flowing and pull it off the valve.
7. Pull the tube end out of the brewer and position over sink or bucket.
8. Release the crimped tube and hose clamp and allow the water to flow into the sink or container.
9. Reverse steps 4-8 when service is complete. Ensure pinch clamp is open and hose clamps are in place.

Brewer	Hot Water Tank Capacity	OPEN Leave open for use	
CBS-1231 Single	3.3 gal 12.3 liter	PINCH SHUT To drain tank & service brewer	
CBS-1232 Twin	6.0 gal 22.4 liter		



Installation safety and hygiene directions-For International and CE equipment

1. Access to the service area is restricted to persons having safety/hygiene knowledge and practical experience of the coffee brewer. This appliance must be installed in locations where it can be overseen by trained personnel.
2. For proper operation, this appliance must be installed indoors where the temperature is between 10°C/50°F to 35°C/95°F. Drain and remove all liquid from equipment and lines if exposed to freezing temperatures.
3. All commercial cooking equipment, including this unit, is not intended for use by children or persons with reduced physical, sensory, or mental capabilities. Ensure proper supervision of children and keep them away from the unit.
4. Children should be supervised to ensure that they do not play hot beverage equipment.
5. This unit must be installed and serviced by qualified personnel only.
6. Installation must conform to all local electrical and plumbing codes. Installation by unqualified personnel will void the unit warranty and may lead to electric shock or burn, as well as damage to unit and/or its surroundings.
7. If the power cord requires repair or replacement-it must be performed by the manufacturer or authorized service personnel with the specified cord only from the manufacturer in order to avoid a hazard.
8. Review the dimensions for the unit and verify that it will fit properly in the space intended for it. Verify that the counter or table will support the total weight of the brewer and dispensers when filled (See: Technical Data).
9. Place the brewer on the counter or stand. When the brewer is in position, level it front to back as well as side-to-side by adjusting the legs.
10. Brewers will need a sturdy supported surface for operation. Do not move brewers when filled.
11. Do not tilt appliance more than 10° to insure safe operation.
12. Unit is for protected indoor use only. Do not steam clean or use excessive water on unit.
13. This unit is not “jet-proof” construction. Do not pressure wash or use jet spray to clean this unit.
14. The unit is not waterproof-do not submerge or saturate with water.

**Equipment exposed to flood and contaminated must not be used due to electrical and food safety.
Do not operate if unit has been submerged or saturated with water.**

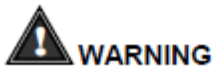

WARNING

All electrical connections must be in accordance with local electrical codes and any other applicable codes. If the supply cord is damaged, it must be replaced by the manufacturer, its service agent, or similarly qualified persons in order to avoid a hazard.

To prevent an electric shock hazard this device must be bonded to equipment in close proximity with an equipotential bonding conductor. This device is equipped with a bonding lug for this purpose and is marked with the following symbol



	WARNING	To reduce risk of electric shock or fire.
		FETCO® Hot Beverage Equipment is for commercial use only.
		Do not remove or open cover. No user serviceable parts inside. Refer installation and service to qualified personnel.
		Caution, disconnect from power supply before servicing.
		GROUND: National Electrical Code requires separate grounding wire.
		Use dedicated circuit with capacity rated by local code or National Electrical Code for the current draw of this equipment. Check serial number plate on right side for power requirements.
		Locate unit away from source of heat. Do not install or use near combustibles.
		THIS APPLIANCE IS ENERGIZED WHENEVER IT IS CONNECTED TO A POWER SOURCE
		FAILURE TO COMPLY RISKS EQUIPMENT DAMAGE, PROPERTY DAMAGE, FIRE, OR SHOCK HAZARD
Notice		This equipment must be installed with a backflow protection device to comply with federal, state or local municipality codes.
Notice		Read the user guide before installing and operating this unit.

Labels and warnings for hot beverage equipment

For BACK PANEL of equipment (1046.00035.00)

Brewer Setup

NOTE-Assemble legs after unpacking the brewer and before connection to utilities

1) attach legs for 3 Liter/ 1 Gallon dispensing



STANDARD WITH UNIT
1" legs -
Attach this length for
3 Liter air pot configuration



NOT INCLUDED. Purchase separately
2-1/2" legs -
Attach this length for
1 Gallon dispenser or 3 liter air pot.
Part number 1073.00016.00
3 required for CBS-1232
4 required for CBS-1231

Legs are sent from factory inside brew basket. Attach legs before installing

2) Adjust dispenser locator for either 3 Liter / 1 Gallon dispensing

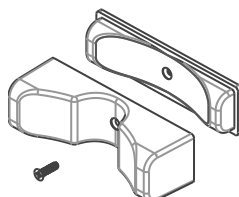
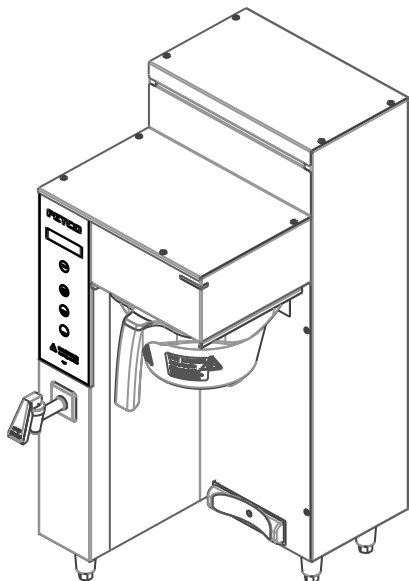

Set Dispenser Locator
← Shown with **1 gallon dispenser**
locator
-(User option)

Shown with **3 liter air pot** Locator
→
-(Factory installed)

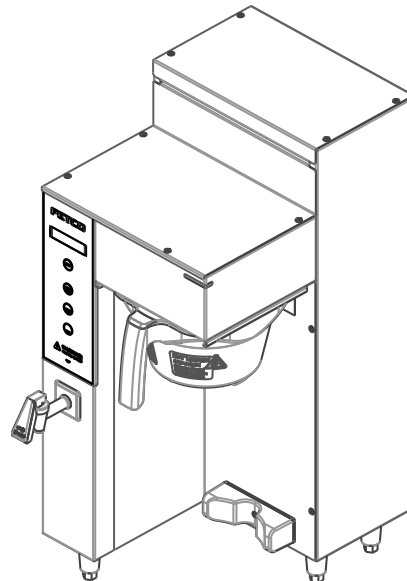

Layout of the brewer

Operation and service

Brew basket
Keypad for brewer operation
Hot Water Faucet

ON/OFF Switch
Air pot or Dispenser Locator
(Two for twin side)

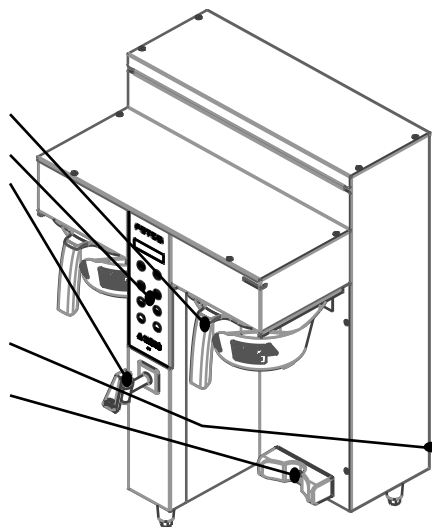

For installing brewer

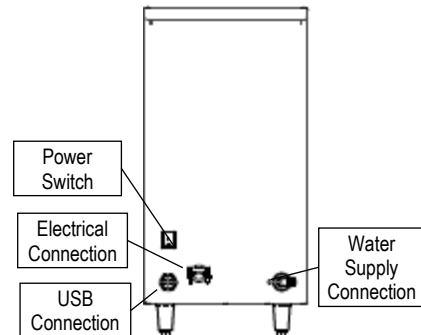

SELECT brewer model
From SERVICE MENU (Page 9) go to position F3
Select model and SAVE and EXIT (Page 11)
Be certain to SAVE new settings

Parts Diagram CBS-1231

Drawing 1101.00570.00
Parts CBS-1231

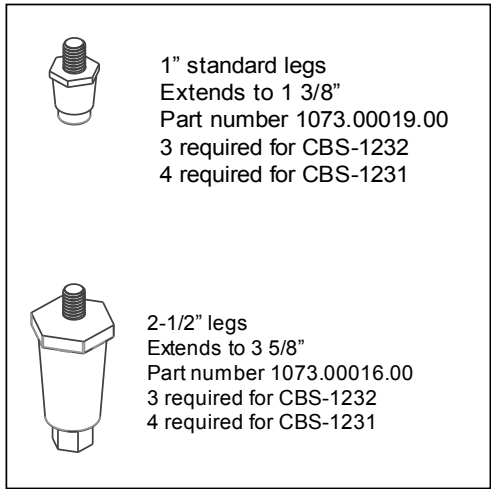
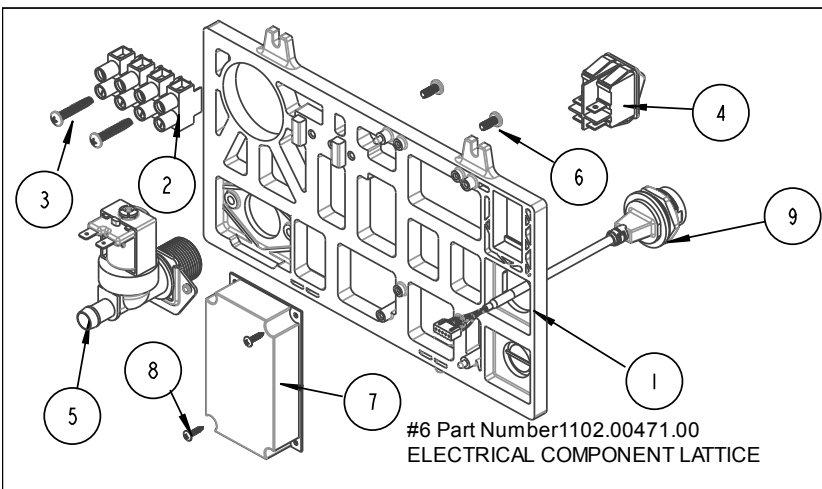
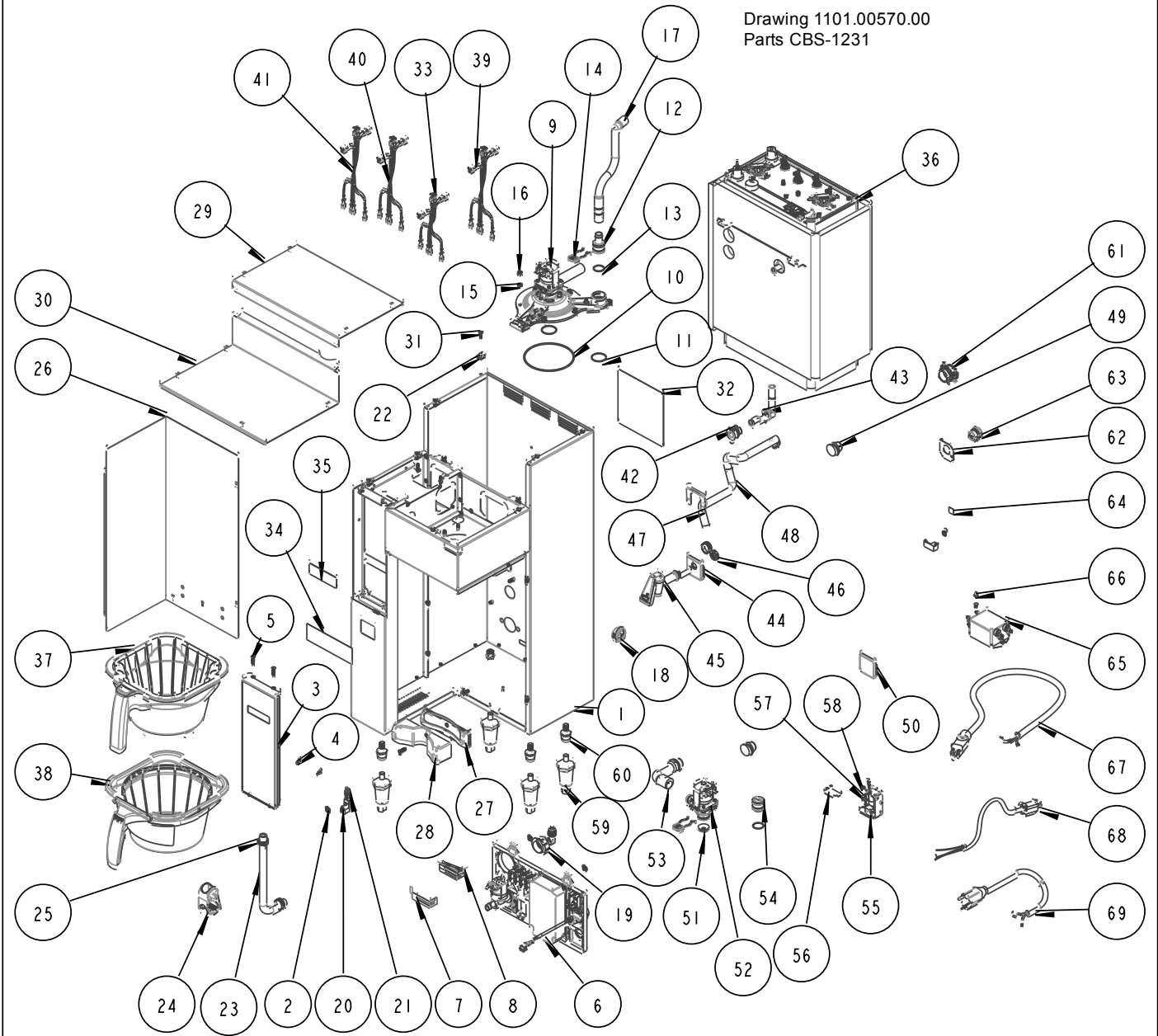

Ref	Qty	Part Number	Description Drawing 1101.00570.00, CBS-1231
1	1	1111.00102.00	WELDMNT BODY, CBS-2231
2	6	1084.00051.00	NUT, HEX LOCKWASHER, #8-32, 18-8 ST. STL.
3	1	1102.00480.00	FRONT PANEL ASSY, SINGLE, PLUS SERIES
4	2	1082.00029.00	SCREW, #6 X 3/8 LG, TRUSS HD PHIL, SHEET MTL
5	3	1082.00058.00	SCREW, # 8-32 X 5/8, FLAT HD, PH, 18-8 SS
6 REF	1	Reference	ELECTRICAL COMPONENT LATTICE, NEXT GEN XV+
6-1	1	1023.00350.00	ELECTRICAL MOUNTING LATTICE, COMMON
6-2	1	1052.00023.00	EUROSTRIP HE16 TERM. BLOCK, 4 POLE, 63 AMP, 18-8 AWG
6-3	2	1082.00056.00	SCREW, # 8-16 x 1" PAN HD PHIL, THREAD FORMING, FOR PLASTICS, 18-8 SS
6-4	2	1058.00024.00	SWITCH, POWER, DOUBLE POLE, 16A, 125/250 VAC
6-5	4	1057.00043.00	SOLENOID VALVE, 5.5L/min, 180 DEG, 24VDC
6-6	2	1082.00010.00	SCREW, PAN HD. PHIL. MACH., M4x10 ZINC-PLATED
6-7	1	1052.00059.00	POWER SUPPLY, 90-264VAC/24VDC, 2.25A
6-8	2	1082.00020.00	SCREW, #6 X 5/8, TRUSS HD PHIL, SHEET MTL
6-9	2	1058.00055.00	USB CONNECTOR
7	1	1097.00171.00	ADHESIVE, RGB LED BAR
8	1	1023.00390.00	LENS, LIGHT BAR, BLACK
9	1	1102.00451.00	QUICK CONNECT SRAYHEAD ASSEMBLY,30/40'S, BASIC (see page 25 for parts breakdown)
10	1	1024.00063.00	O-RING, 3 15/16" x 3/32" CS, DASH # 154, BUNA-N, DURO-A50
11	2	1024.00107.00	O-RING, 1 3/16" OD X 1 1/16" ID X 1/16" TH, BYPASS SEAL
12	1	1023.00343.00	VENT INSERT, QUICK CONNECT
13	2	1024.00106.00	O-RING, 13/16"OD X 11/16"ID X 1/16" TH, FOR QUICK CONNECT
14	2	1023.00342.00	QUICK CONNECT CLIP
15	9	1083.00010.00	WASHER, #10 SCREW W/NEOPRENE-BONDED SEAL
16	9	1084.00006.00	NUT, 8-32 18-8 HEX MACHINE SCREW
17	1	1024.00098.00	VENT TUBE, CBS- EXTRACTOR SERIES
18	1	1086.00004.00	BUSHING, SNAP, 1" MOUNTING HOLE
19	1	1102.00243.00	ADAPTER ASSY, 3/4" BSP x 1/4" NPT x 3/8" TUBE
20	2	1065.00009.00	GROUND LUG CONNECTOR, 14-2 AWG, ALUMINUM
21	1	1044.00012.00	LABEL GROUND, CE
22	11	1084.00011.00	NUT, CLIP ON (J-NUT), #6-32, 22-20 GA., BLK-PH FINISH
23	1	1025.00058.00	TUBE, 9/16"OD X 5/16"ID X 25.00"LG
24	1	1086.00009.00	CLAMP, 3/4" MAX TUBE OD FLOW CONTROL
25	4	1086.00003.00	UNICLAMP, 15.9 HOSE OD CLAMP
26	1	1112.00530.00	WELDMNT, RIGHT COVER, CBS-2230
27	1	1023.00354.00	LOCATOR, DISPENSER, CBS-2230
28	1	1023.00355.00	LOCATOR, AIRPOT ADAPTER, CBS-2230
29	1	1001.00413.00	COVER TOP, CBS-2231/41
30	1	1001.00414.00	COVER, UPPER BASE, CBS-2231/41
31	11	1082.00017.00	SCREW, TRUSS HD. PHIL. MACHINE, # 6-32 X 1/2 LG
32	1	1046.00035.00	LABEL, WARNING "TO REDUCE RISK OF ELECTRIC SHOCK OR FIRE"
33	1	1402.00098.10	HARNESS, LOW AMP, CBS-1230, UL
34	1	1046.00003.00	LABEL, CSD WARNING, 1.5" X 5.0"
35	1	1041.00033.00	BLACK EXTRACTOR PLUS LABEL, LASER ENGRAVED
36	1	1104.00169.00	TANK ASSEMBLY, CBS-2231, 1 X 1.5KW/120VAC
36	1	1104.00170.00	TANK ASSEMBLY, CBS-2231, 1 X 1.7KW/120VAC
36	1	1104.00174.00	TANK ASSEMBLY, CBS-2231, 1 X 2.3KW/240VAC
36	1	1104.00172.00	TANK ASSEMBLY, CBS-2231, 1 X 2.3KW/120VAC
36	1	1104.00175.00	TANK ASSEMBLY, CBS-2231, 1 X 3KW/240VAC
36	1	1104.00171.00	TANK ASSEMBLY, CBS-2231, 2 X 1.7KW/120VAC
36	1	1104.00173.00	TANK ASSEMBLY, CBS-2231, 2 X 2.3KW/120VAC
37	1	B014218BN2B	K BREW BASKET ASSY, 13" X 5", 0.218" DIA HOLE, BROWN PLUG
38	1	B003218B1	BREW BASKET ASSY, 13" X 5", .218 DIA HOLE, BLACK
39	1	1402.00039.10	HARNESS HIGH AMP, CBS-2231/41/51, UL
40	1	1402.00039.11	HARNESS ADDITION, HIGH AMP, CBS-2231/41/51, UL
41	1	1402.00121.10	WIRE HARNESS ADDITION, HIGH AMP, EMI FILTER, 2-POLE, CE
42	1	1024.00111.00	GROMMET, SILICONE, W/ POSITION TABS
43	1	1023.00362.00	FITTING VENT, ELBOW, .375" X .375", SELF POSITIONING
44	1	1023.00348.00	HOT WATER INSERT, MANUAL FAUCET
45	1	1071.00055.00	FAUCET, HOT WATER, PSC-BR-8, WITH FLAT AND STEM
46	1	1084.00048.00	JAM NUT, 1/2-20 UNF, NICKEL PLATED BRASS
47	1	1003.00370.00	HOT WATER INSERT LOCK
48	1	1025.00120.00	TUBE, 9/16"OD X 5/16"ID X 13.00"LG
49	2	1024.00051.00	GROMMET, SILICONE, BLANK
50	1	1023.00349.00	HOT WATER INSERT, NO FAUCET
51	1	1023.00369.00	ORIFICE INSERT, QUICK CONNECT, 3/16" HOLE
52	1	1057.00076.00	VALVE ASSEMBLY, COMPLETE, NG, DELTROL
53	1	1029.00042.00	BYPASS L-TUBE, SILICONE, 2200 SINGLE SERIES
54	1	1023.00344.00	PLUG INSERT, QUICK CONNECT
55	1	1102.00219.00	ASSEMBLY, BB LOCKER, 24VDC
56	1	1003.00259.00	BRACKET, BREW BASKET LOCK COVER
57	4	1083.00009.00	WASHER, #6 SCREW , INTL TOOTH LOCKWASHER
58	2	1084.00010.00	NUT, HEX, #6-32, UNDERSIZED, ZINC PLATED
59	4	1073.00016.00	LEG, THERMOPLASTIC, 2.50"(63mm)
60	4	1073.00019.00	LEG, 3/8-16 THREAD x 1" LG., GRAY
61	1	1086.00008.00	CONNECTOR, CLAMP, NON-METALLIC CABLE, 3/4"
62	1	1003.00348.00	ADAPTER PLATE, CBS-1130-XV+, STRAIN RELIEF, CE
63	1	1086.00029.00	BUSHING, STRAIN RELIEF, .360"-.430" DIA CABLE
64	1	1044.00013.00	LABEL EQUIPOTENTIALITY, CE
65	1	1052.00029.00	EMI FILTER, TWO LINE 20A, 120/250VAC
66	2	1084.00012.00	NUT, HEX, #6-32 MACHINE SCREW
67	1	1063.00016.00	POWER CORD, 120VAC W/NEMA 5-15P PLUG
68	1	1063.00015.00	CORD, 120 VAC, 12/3 AWG .20 AMP , W/5-20P NEMA PLUG
69	1	1063.00032.00	CORD, POWER, NEMA 6-15P, 15A/250V, W/O TERMINALS



Parts Diagrams CBS-1232

Drawing 1101.00571.00
Parts CBS-1232

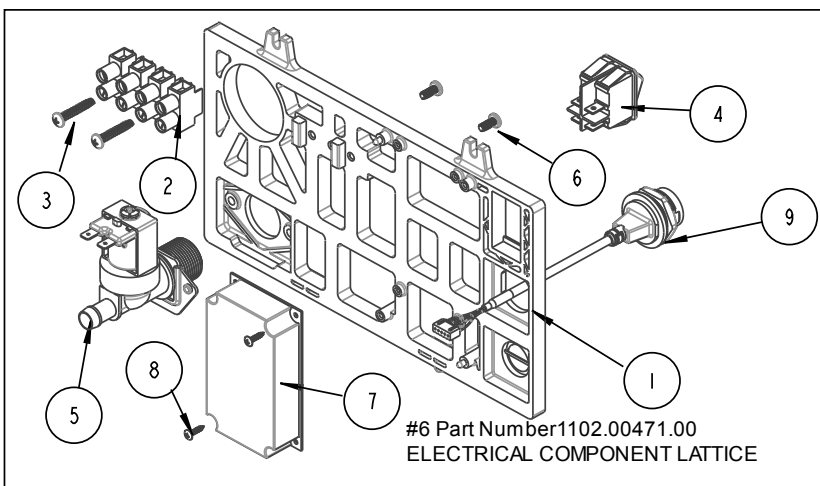
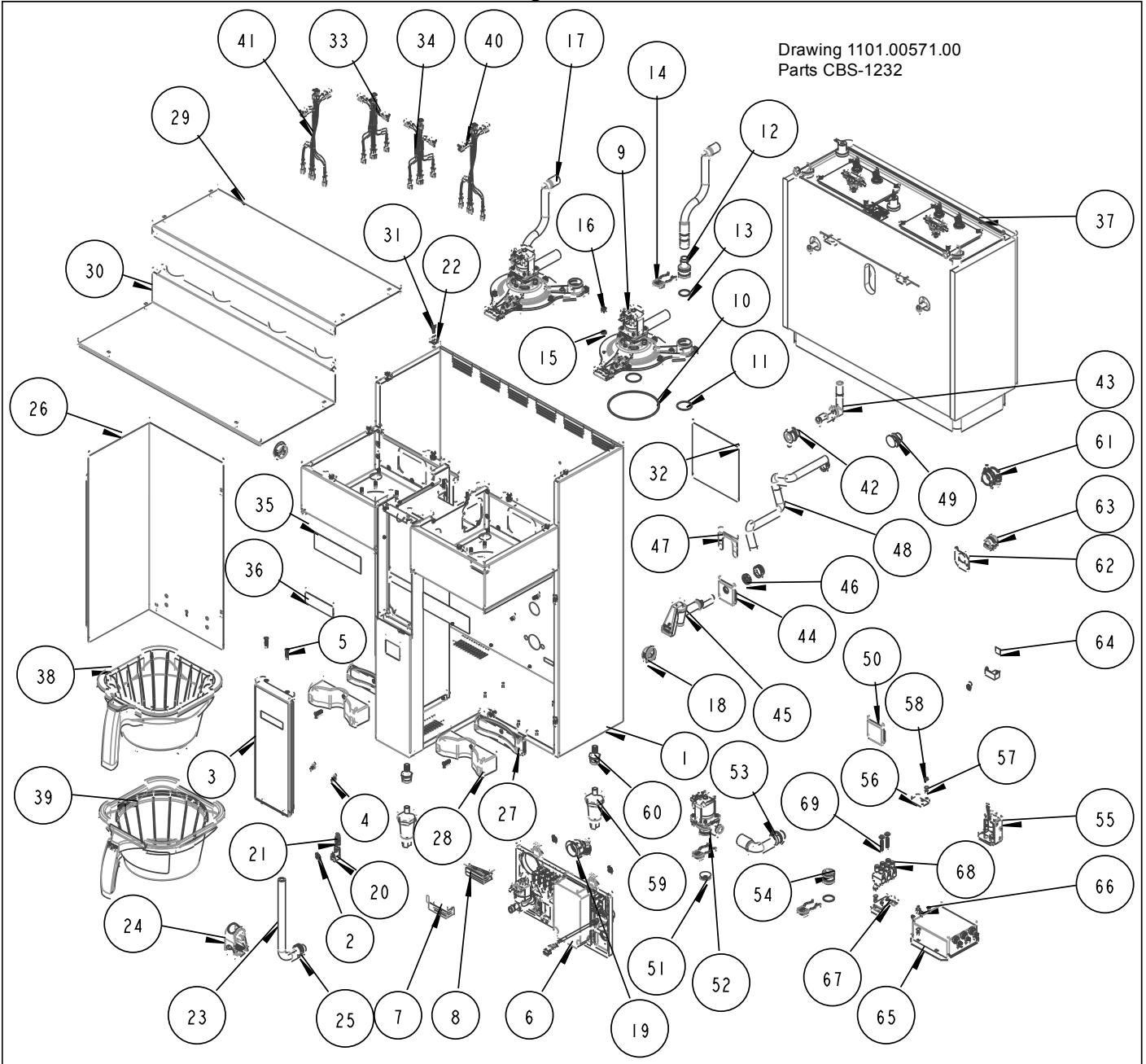

1" standard legs
Extends to 1 3/8"
Part number 1073.00019.00
3 required for CBS-1232
4 required for CBS-1231



2-1/2" legs
Extends to 3 5/8"
Part number 1073.00016.00
3 required for CBS-1232
4 required for CBS-1231



Ref	Qty	Part Number	Description Drawing 1101.00571.00, CBS-1232
1	1	1111.00101.00	WELDMENT BODY, CBS-2232
2	6	1084.00051.00.	NUT, HEX LOCKWASHER, #8-32, 18-8 ST. STL
3	1	1102.00470.00	FRONT PANEL ASSY, DOUBLE, PLUS SERIES
4	2	1082.00029.00	SCREW, #6 X 3/8 LG, TRUSS HD PHIL, SHEET MTL
5	4	1082.00058.00	SCREW, # 8-32 X 5/8, FLAT HD, PH, 18-8 SS
6 REF	1	Reference	ELECTRICAL COMPONENT LATTICE, NEXT GEN XV+
6-1	1	1023.00350.00	ELECTRICAL MOUNTING LATTICE, COMMON
6-2	1	1052.00023.00	EUROSTRIP HE16 TERM. BLOCK, 4 POLE, 63 AMP, 18-8 AWG
6-3	2	1082.00056.00	SCREW, # 8-16 x 1" PAN HD PHIL, THREAD FORMING, FOR PLASTICS, 18-8 SS
6-4	2	1058.00024.00	SWITCH, POWER, DOUBLE POLE, 16A, 125/250 VAC
6-5	4	1057.00043.00	SOLENOID VALVE, 5.5L/min, 180 DEG, 24VDC
6-6	2	1082.00010.00	SCREW, PAN HD. PHIL. MACH., M4x10 ZINC-PLATED
6-7	1	1052.00059.00	POWER SUPPLY, 90-264VAC/24VDC, 2.25A
6-8	2	1082.00020.00	SCREW, #6 X 5/8, TRUSS HD PHIL, SHEET MTL
6-9	2	1058.00055.00	USB CONNECTOR
7	1	1097.00171.00	ADHESIVE, RGB LED BAR
8	1	1023.00390.00	LENS, LIGHT BAR, BLACK
9	2	1102.00451.00	QUICK CONNECT SRAYHEAD ASSEMBLY,30/40'S, BASIC (see page 25 for parts breakdown)
10	2	1024.00063.00	O-RING, 3 15/16" x 3/32" CS, DASH # 154, BUNA-N, DURO-A50
11	4	1024.00107.00	O-RING, 1 3/16" OD X 1 1/16" ID X 1/16" TH, BYPASS SEAL
12	2	1023.00343.00	VENT INSERT, QUICK CONNECT
13	3	1024.00106.00	O-RING, 13/16"OD X 11/16"ID X 1/16" TH, FOR QUICK CONNECT
14	4	1023.00342.00	QUICK CONNECT CLIP
15	18	1083.00010.00	WASHER, #10 SCREW W/NEOPRENE-BONDED SEAL
16	18	1084.00006.00	NUT, 8-32 18-8 HEX MACHINE SCREW
17	2	1024.00098.00	VENT TUBE, CBS- EXTRACTOR SERIES
18	2	1086.00004.00	BUSHING, SNAP, 1" MOUNTING HOLE
19	1	1102.00243.00	ADAPTER ASSY, 3/4" BSP x 1/4" NPT x 3/8" TUBE
20	2	1065.00009.00	GROUND LUG CONNECTOR, 14-2 AWG, ALUMINUM
21	1	1044.00012.00	LABEL GROUND, CE
22	11	1084.00011.00	NUT, CLIP ON (J-NUT), #6-32, 22-20 GA., BLK-PH FINISH
23	1	1025.00058.00	TUBE, 9/16"OD X 5/16"ID X 25.00"LG
24	1	1086.00009.00	CLAMP, 3/4" MAX TUBE OD FLOW CONTROL
25	3	1086.00003.00	UNICLAMP, 15.9 HOSE OD CLAMP
26	1	1112.00530.00	WELDMENT, RIGHT COVER, CBS-2230
27	2	1023.00354.00	LOCATOR, DISPENSER, CBS-2230
28	2	1023.00355.00	LOCATOR, AIRPOT ADAPTER, CBS-2230
29	1	1001.00408.00	COVER TOP, CBS-2232/42
30	1	1001.00409.00	COVER, UPPER BASE, CBS-2232/42
31	11	1082.00017.00	SCREW, TRUSS HD. PHIL. MACHINE, # 6-32 X 1/2 LG.
32	1	1046.00035.00	LABEL, WARNING "TO REDUCE RISK OF ELECTRIC SHOCK OR FIRE"
33	1	1402.00098.10	HARNESS, LOW AMP, CBS-1230, UL
34	1	1402.00098.11	HARNESS ADDITION, LOW AMP, CBS-1232/42, UL
35	2	1046.00003.00	LABEL, CSD WARNING, 1.5" X 5.0"
36	1	1041.00033.00	BLACK EXTRACTOR PLUS LABEL, LASER ENGRAVED
37	1	1104.00176.00	TANK ASSEMBLY, CBS-2232, 2 X 2.3KW/240VAC
37	1	1104.00177.00	TANK ASSEMBLY, CBS-2232, 2 X 3KW/240VAC
37	1	1104.00191.00	TANK ASSEMBLY, CBS-2232, 2 X 4KW/240VAC
38	1	B014218BN2BK	BREW BASKET 13" X 5", 0.218" DIA HOLE, BROWN PLUG
39	1	B003218B1	BREW BASKET ASSY, 13" X 5", .218 DIA HOLE, BLACK
40	1	1402.00037.10	HARNESS HIGH AMP, CBS-2232/42/51, UL
41	1	1402.00121.10	WIRE HARNESS ADDITION, HIGH AMP, EMI FILTER, 2-POLE, CE
42	1	1024.00111.00	GROMMET, SILICONE, W/ POSITION TABS
43	1	1023.00362.00	FITTING VENT, ELBOW, .375" X .375", SELF POSITIONING
44	1	1023.00348.00	HOT WATER INSERT, MANUAL FAUCET
45	1	1071.00055.00	FAUCET, HOT WATER, PSC-BR-8, WITH FLAT AND STEM
46	1	1084.00048.00	JAM NUT, 1/2-20 UNF, NICKEL PLATED BRASS
47	1	1003.00370.00	HOT WATER INSERT LOCK
48	1	1025.00120.00	TUBE, 9/16"OD X 5/16"ID X 13.00"LG
49	1	1024.00051.00	GROMMET, SILICONE, BLANK
50	1	1023.00349.00	HOT WATER INSERT, NO FAUCET
51	1	1023.00369.00	ORIFICE INSERT, QUICK CONNECT, 3/16" HOLE
52	1	1057.00076.00	VALVE ASSEMBLY, COMPLETE, NG, DELTROL
53	1	1029.00042.00	BYPASS L-TUBE, SILICONE, 2200 SINGLE SERIES
54	1	1023.00344.00	PLUG INSERT, QUICK CONNECT
55	1	1102.00219.00	ASSEMBLY, BB LOCKER, 24VDC
56	1	1003.00259.00	BRACKET, BREW BASKET LOCK COVER
57	3	1083.00009.00	WASHER, #6 SCREW , INTL TOOTH LOCKWASHER
58	1	1084.00010.00	NUT, HEX, #6-32, UNDERSIZED, ZINC PLATED
59	3	1073.00016.00	LEG, THERMOPLASTIC, 2.50"(63mm)
60	3	1073.00019.00	LEG, 3/8-16 THREAD x 1" LG., GRAY
61	1	1086.00008.00	CONNECTOR, CLAMP, NON-METALLIC CABLE, 3/4"
62	1	1003.00348.00	ADAPTER PLATE, CBS-1130-XV+, STRAIN RELIEF, CE
63	1	1086.00029.00	BUSHING, STRAIN RELIEF, .360"-.430" DIA CABLE
64	1	1044.00013.00	LABEL EQUIPOTENTIALITY, CE
65	1	1052.00027.00	EMI FILTER, THREE LINE 30A, 250/440VAC
66	2	1084.00012.00	NUT, HEX, #6-32 MACHINE SCREW
67	1	1112.00246.00	WELDMENT BRACKET TERMINAL BLOCK, 3 POLE
68	1	1052.00022.00	EUROSTRIP HE10 TERM. BLOCK, 3 POLE, 50AMP, 18-8 AWG
69	2	1082.00082.00	SCREW, PHILLIP HD., 8-32 THREAD



CBS-1231 Tank Assembly

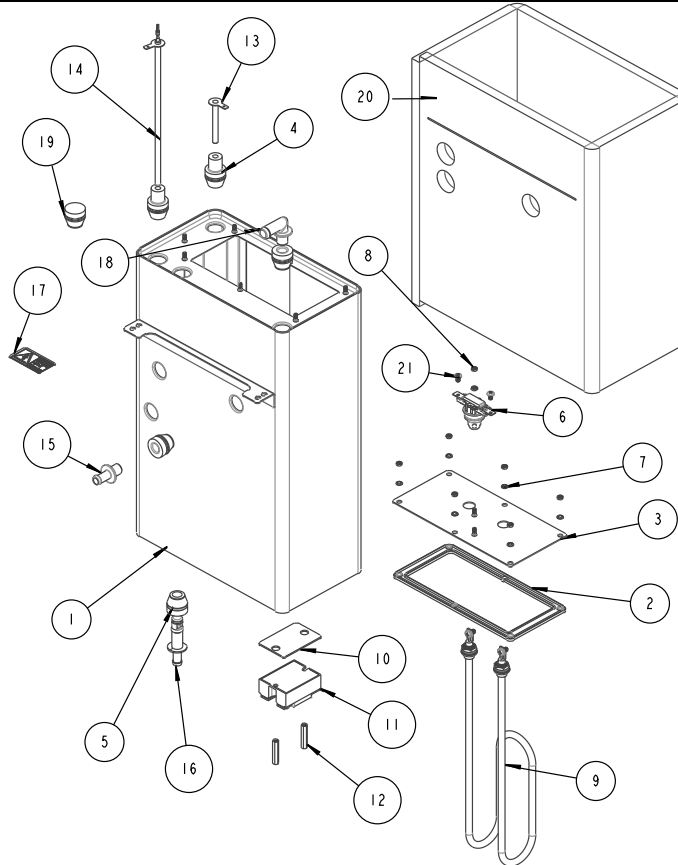

TANK ASSY, CBS-1231 Single Heater				Drawing number 1104.000169.00, 1104.000170.00, 1104.000172.00, 1104.000174.00, 1104.000175.00			
REF	QTY	Part number	Description				
1	1	1114.00168.001	WELDMENT, TANK, CBS-2231				
2	1	1024.00114.00	TANK GASKET - NG HEATER PLATE, TWO ELEMENT				
3	1	1114.00184.00	WELDMENT TANK HEATER BRACKET, NG-2231, SINGLE				
4	2	1024.00053.00	LEVEL AND TEMP PROBE GROMMET				
5	3	1024.00050.00	GROMMET, SILICONE, 11.4mm ID				
6	1	1053.00052.00	THERMOSTAT, SINGLE SHOT, SCREW CONNECTIONS, 240V/25A				
7	8	1083.00009.00	WASHER, #6 SCREW , INTL TOOTH LOCKWASHER				
8	8	1084.00010.00	NUT, HEX, #6-32, UNDERSIZED, ZINC PLATED				
9	1	1107.00021.00	HEATER ASSEMBLY, IMMERSION 1500W/120VAC				
9	1	1107.00022.00	HEATER ASSEMBLY, IMMERSION 1700W/120VAC				
9	1	1107.00020.00	HEATER ASSEMBLY, IMMERSION 2300W/240VAC				
9	1	1107.00019.00	HEATER ASSEMBLY, IMMERSION 2300W/120VAC				
9	1	1107.00018.00	HEATER ASSEMBLY, IMMERSION 3000W/240VAC				
10	1	1003.00140.00	ALUMINUM BRACKET FOR SSR				
11	1	1052.00033.00	RELAY, SOLID STATE, 50A/480VAC, W/BUILD IN VARISTOR				
12	2	1081.00042.00	STANDOFF, 1/4" HEX				
13	1	1112.00002.00	PROBE WELDMENT, WATER LEVEL 2.25" LG				
14	1	1102.00161.00	PROBE ASSEMBLY, TEMP. AND LLC, 8" LONG				
15	1	1023.00168.00	FITTING, STRAIGHT, GROMMET, .400"				
16	1	1023.00166.00	FITTING, COLD WATER INLET, GROMMET DESIGN				
17	1	1044.00004.00	LABEL, DANGER, HIGH VOLTAGE				
18	1	1023.00212.00	FITTING, ELBOW, GROMMET, .500"				
19	1	1024.00051.00	GROMMET, SILICONE, BLANK				
20	1	1022.00114.00	TANK INSULATION, CBS-2231				
21	2	1082.00136.00	BRASS SCREW, #8-32 X 1/4", PHILLIPS PAN HEAD				



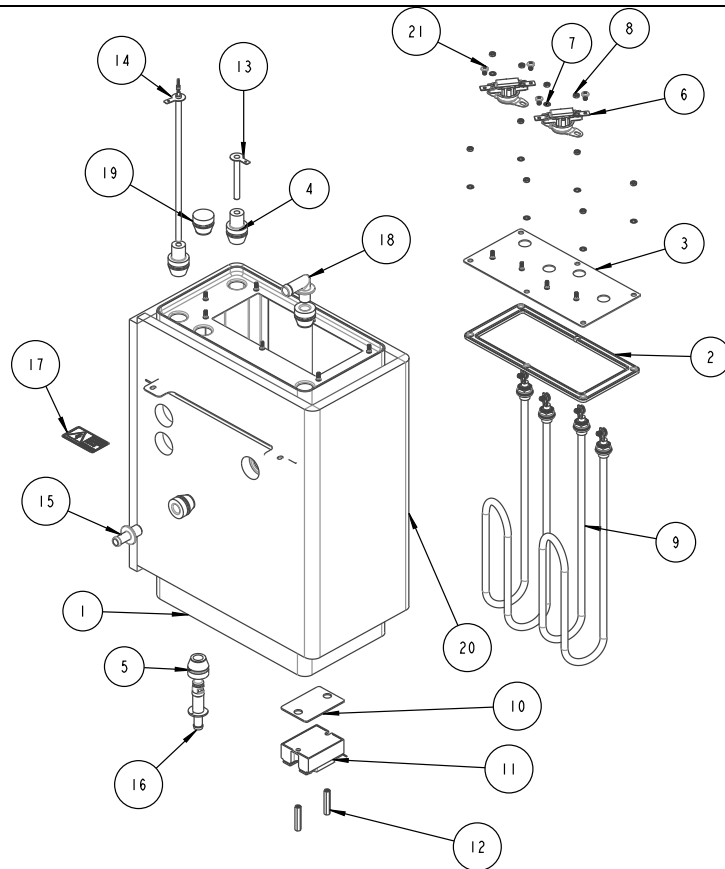

TANK ASSY, CBS-1231 Two Heater Drawing number 1104.000171.00, 1104.000173.00

REF	QTY	Part number	Description
1	1	1114.00168.00	WELDMENT, TANK, CBS-2231
2	1	1024.00114.00	TANK GASKET - NG HEATER PLATE, TWO ELEMENT
3	1	1114.00176.00	WELDMENT TANK HEATER BRACKET, NG-2231
4	2	1024.00053.00	LEVEL AND TEMP PROBE GROMMET
5	3	1024.00050.00	GROMMET, SILICONE, 11.4mm ID
6	2	1053.00052.00	THERMOSTAT, SINGLE SHOT, SCREW CONNECTIONS, 240V/25A
7	10	1083.00009.00	WASHER, #6 SCREW , INTL TOOTH LOCKWASHER
8	10	1084.00010.00	NUT, HEX, #6-32, UNDERSIZED, ZINC PLATED
9	2	1107.00022.00	HEATER ASSEMBLY, IMMERSION 1700W/120VAC
9	2	1107.00019.00	HEATER ASSEMBLY, IMMERSION 2300W/120VAC
10	2	1003.00140.00	ALUMINUM BRACKET FOR SSR
11	2	1052.00033.00	RELAY, SOLID STATE, 50A/480VAC, W/BUILD IN VARISTOR
12	4	1081.00042.00	STANDOFF, 1/4" HEX
13	1	1112.00002.00	PROBE WELDMENT, WATER LEVEL 2.25" LG
14	1	1102.00161.00	PROBE ASSEMBLY, TEMP. AND LLC, 8" LONG
15	1	1023.00168.00	FITTING, STRAIGHT, GROMMET, .400"
16	1	1023.00166.00	FITTING, COLD WATER INLET, GROMMET DESIGN
17	1	1044.00004.00	LABEL, DANGER, HIGH VOLTAGE
18	1	1023.00212.00	FITTING, ELBOW, GROMMET, .500"
19	1	1024.00051.00	GROMMET, SILICONE, BLANK
20	1	1022.00114.00	TANK INSULATION, CBS-2231
21	4	1082.00136.00	BRASS SCREW, #8-32 X 1/4", PHILLIPS PAN HEAD



CBS-1232 Tank Assembly

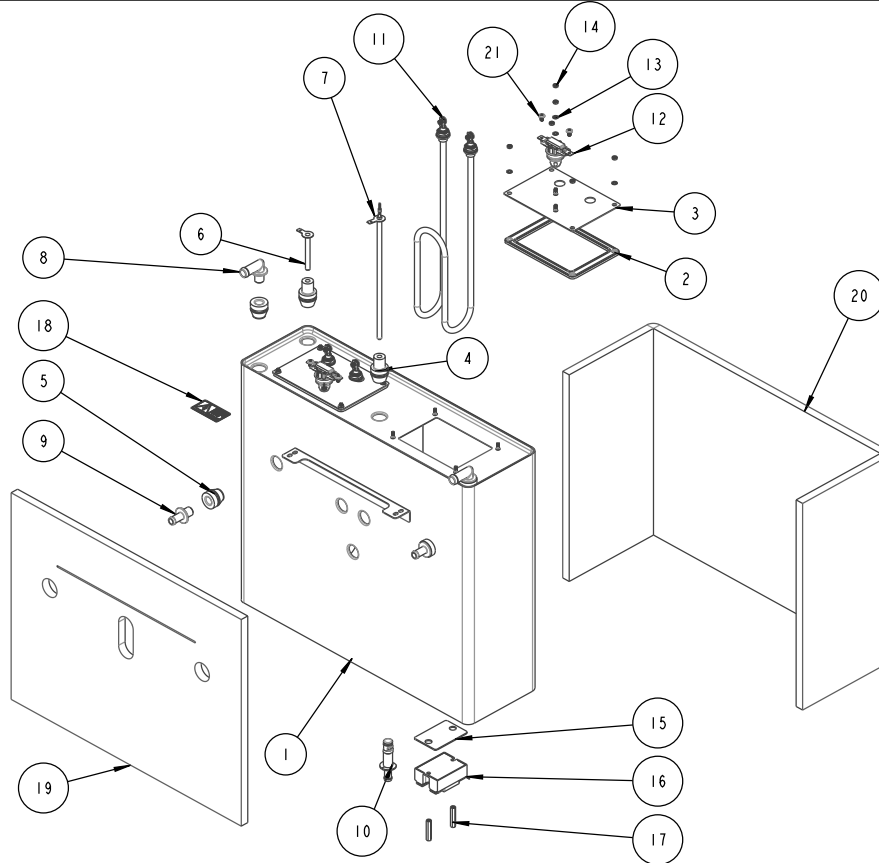

CBS-1232 Hot Water Tank Drawing 1104.00176.00

Ref#	Qty	Part number	Description
1	1	1114.00169.00	WELDMENT TANK CBS-2232, GROMMET DESIGN
2	2	1024.00115.00	TANK GASKET - NG HEATER PLATE, ONE ELEMENT
3	2	1114.00181.00	WELDMENT TANK HEATER BRACKET, NG-2232
4	2	1024.00053.00	LEVEL AND TEMP PROBE GROMMET
5	5	1024.00050.00	GROMMET, SILICONE, 11.4mm ID
6	1	1112.00002.00	PROBE WELDMENT, WATER LEVEL 2.25" LG
7	1	1102.00161.00	PROBE ASSEMBLY, TEMP. AND LLC, 8" LONG
8	2	1023.00212.00	FITTING, ELBOW, GROMMET, .500"
9	2	1023.00168.00	FITTING, STRAIGHT, GROMMET, .400"
10	1	1023.00166.00	FITTING, COLD WATER INLET, GROMMET DESIGN
11	2	1107.00019.00	HEATER ASSEMBLY, IMMERSION 2300W/120VAC
11	2	1107.00020.00	HEATER ASSEMBLY, IMMERSION 2300W/240VAC
11	2	1107.00018.00	HEATER ASSEMBLY, IMMERSION 3kW/240VAC
11	2	1107.00040.00	HEATER ASSEMBLY, IMMERSION 4kW/240VAC
12	2	1053.00052.00	THERMOSTAT, SINGLE SHOT, SCREW CONNECTIONS, 240V/25A,
13	12	1083.00009.00	WASHER, #6 SCREW , INTL TOOTH LOCKWASHER
14	12	1084.00010.00	NUT, HEX, #6-32, UNDERSIZED, ZINC PLATED
15	2	1003.00140.00	ALUMINUM BRACKET FOR SSR
16	2	1052.00033.00	RELAY, SOLID STATE, 50A/480VAC, W/BUILD IN VARISTOR
17	4	1081.00042.00	STANDOFF, 1/4" HEX
18	1	1044.00004.00	LABEL, DANGER, HIGH VOLTAGE
19	1	1022.00113.00	TANK INSULATION, CBS-2232 FRONT
20	1	1022.00116.00	TANK INSULATION, CBS-2232 BACK
21	4	1082.00136.00	BRASS SCREW, #8-32 X 1/4", PHILLIPS PAN HEAD

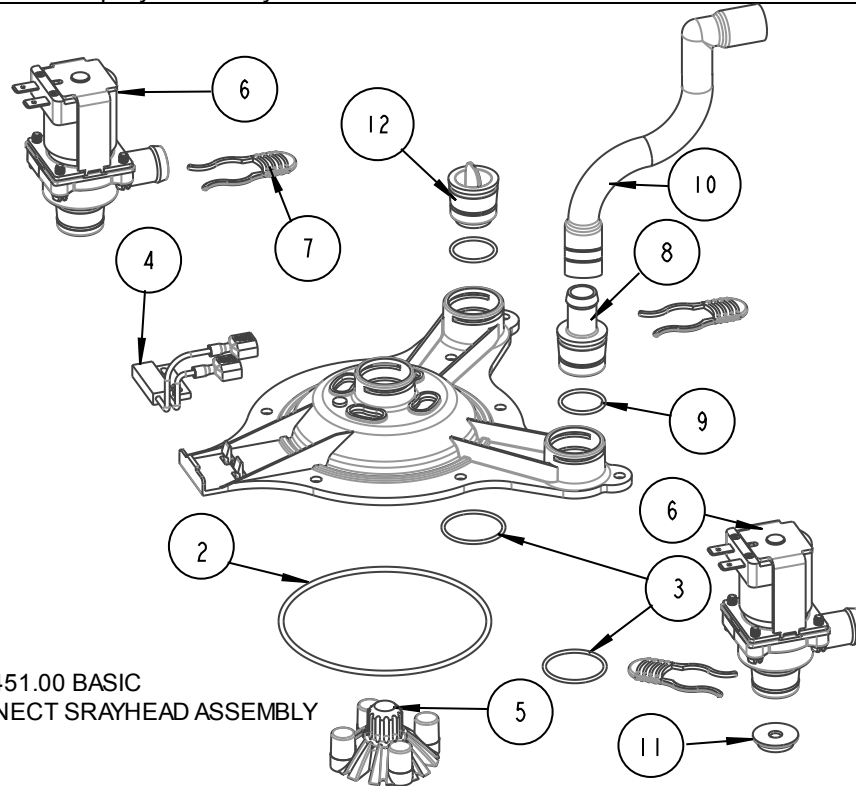

Ref#	Qty	Part number	Description
1	1	1000.00143.00	SPRAY HEAD BASE (KIT), QUICK CONNECT, 30/40'S
2	1	1024.00063.00	O-RING, 3 15/16" x 3/32" CS, DASH # 154, BUNA-N, DURO-A50
3	2	1024.00107.00	O-RING, 1 3/16" OD X 1 1/16" ID X 1/16" TH, BYPASS SEAL
4	1	1102.00113.00	SWITCH, REED, ASSEMBLY
5	1	1102.00479.00	ASSEMBLY, CASCADE SPRAY DOME, NEXT GEN, ORANGE
6	2	1057.00076.00	VALVE ASSEMBLY, COMPLETE, NG, DELTROL (interchangeable with 1057.00078.00)
6	2	1057.00078.00	VALVE ASSEMBLY, COMPLETE, NG, RPE (interchangeable with 1057.00076.00)
7	3	1023.00342.00	QUICK CONNECT CLIP
8	1	1023.00343.00	VENT INSERT, QUICK CONNECT
9	2	1024.00106.00	O-RING, 13/16"OD X 11/16"ID X 1/16" TH, FOR QUICK CONNECT
10	1	1024.00098.00	VENT TUBE, CBS- EXTRACTOR SERIES
11	1	1023.00369.00	ORIFICE INSERT, QUICK CONNECT, 3/16" HOLE
12	1	1023.00344.00	PLUG INSERT, QUICK CONNECT

Brew Baskets

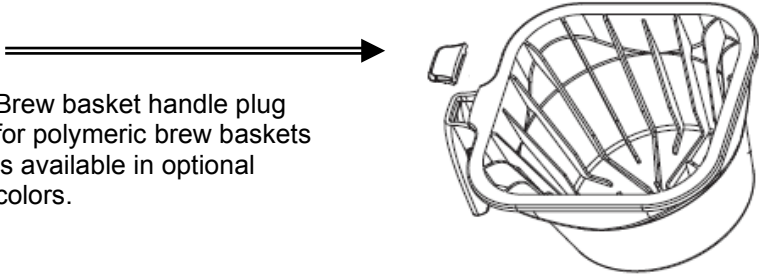
Plastic Brew Basket	
Part Number B014218BN2BK – Complete Plastic Brew Basket	CBS-1231 & CBS-1232
 <p>Brew basket handle plug for polymeric brew baskets is available in optional colors.</p>	Part Number Plug Insert color
	1023.00195.00 BROWN PLUG, BB HANDLE
	1023.00194.00 BLACK PLUG, BB HANDLE
	1023.00190.00 RED PLUG, BB HANDLE
	1023.00191.00 GREEN PLUG, BB HANDLE
	1023.00192.00 ORANGE PLUG, BB HANDLE
	1023.00180.00 BLUE PLUG, BB HANDLE

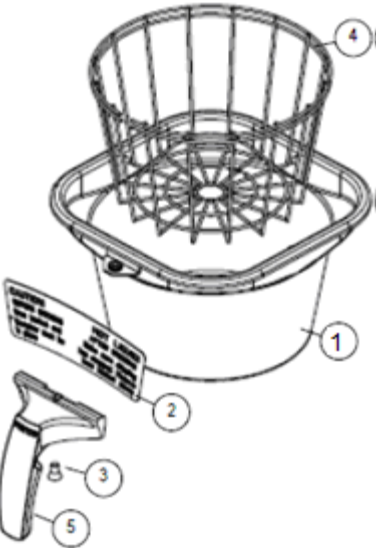
Stainless Steel Brew Basket				
	Ref#	Qty	Part Number	Description
			B003218B1	Complete Stainless Steel Brew Basket
	1	1	1112.00128.00	BB WLDMNT 13" X 5", .218 DIA HOLE
	2	1	1046.00025.00	BREW BASKET WARNING LABEL
	3	1	1082.00040.00	SCREW, 1/4-20 X .5, FL HD, PH., W/NYLN
	4	1	1009.00006.00	WIRE BASKET
	5	1	1102.00064.00	HANDLE W/MAGNET ASY, BLACK
	Optional colored handle		1102.00065.00	HANDLE W/MAGNET ASY, RED
	Optional colored handle		1102.00066.00	HANDLE W/MAGNET ASY, GREEN
Optional colored handle		1102.00067.00	HANDLE W/MAGNET ASY, ORANGE	

Wiring Diagrams

SKU: E1231US-1X117-PM001
CBS-1231 Domestic-Dual Voltage

1PH
120/208-240VAC

FETCO
FOOD EQUIPMENT TECHNOLOGY
6100 ROSE RD.
MILWAUKEE, WI 53213
PHONE: 414-251-9900 FAX: 414-251-9901
WWW.FETCO.COM

DWG. NAME:
WIRING, CBS-1231/41, (N, L1, L2 + 2 HEATERS, 120/208-240VAC, UL.
DRAWING NO. 1401.00189.10

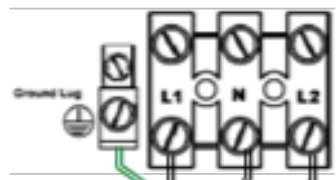
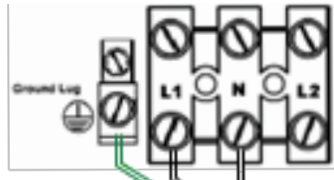
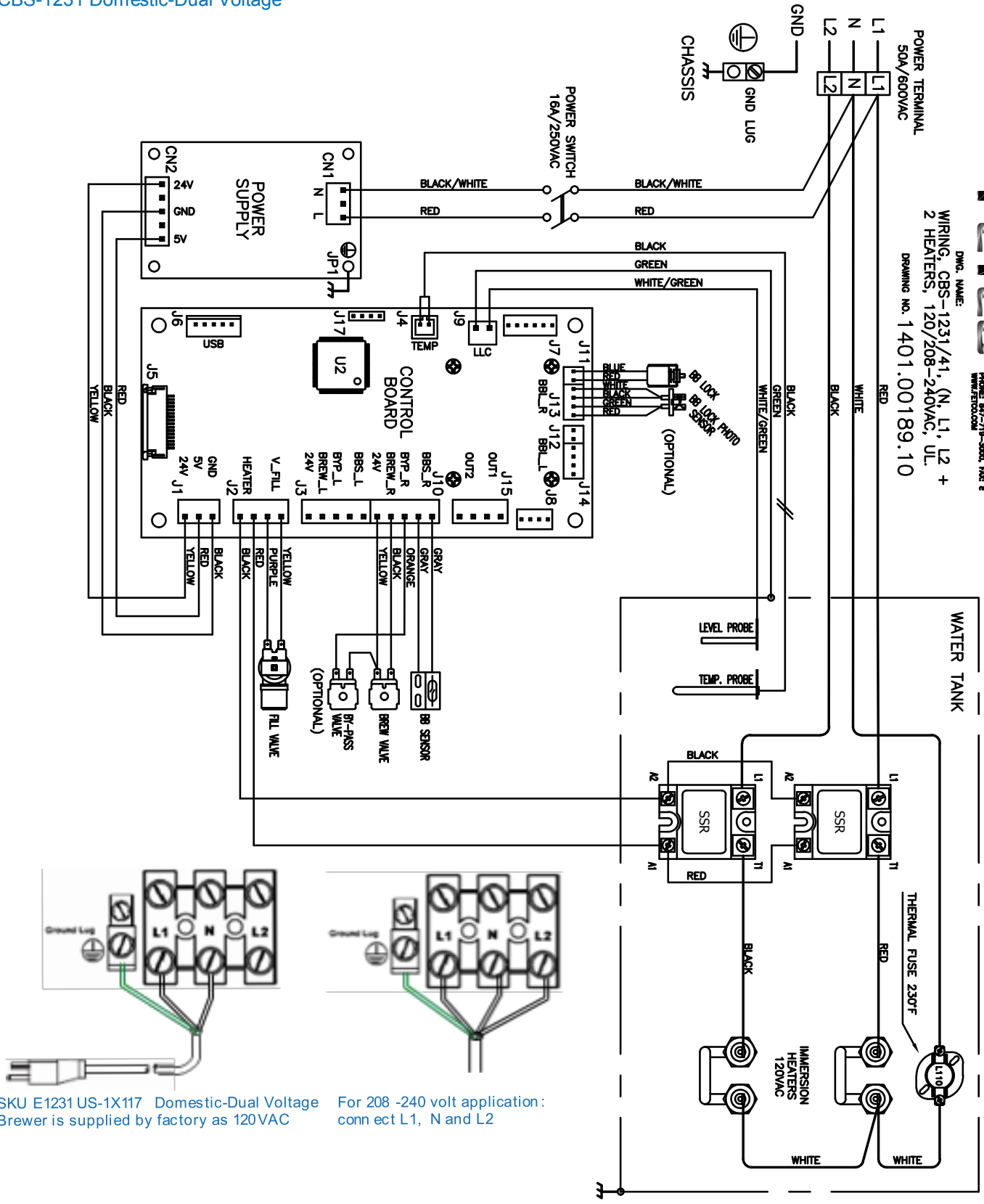

SKU E1231 US-1X117 Domestic-Dual Voltage For 208 -240 volt application :
Brewer is supplied by factory as 120VAC connect L1, N and L2

Wiring diagram 1401.00190.10
 E1231US-1A115, E1231US-1A123, E1231US-1X117, E1231IN-1B130
 CBS-1231Plus

1PH
 100-120VAC
 OR
 (200-240VAC)

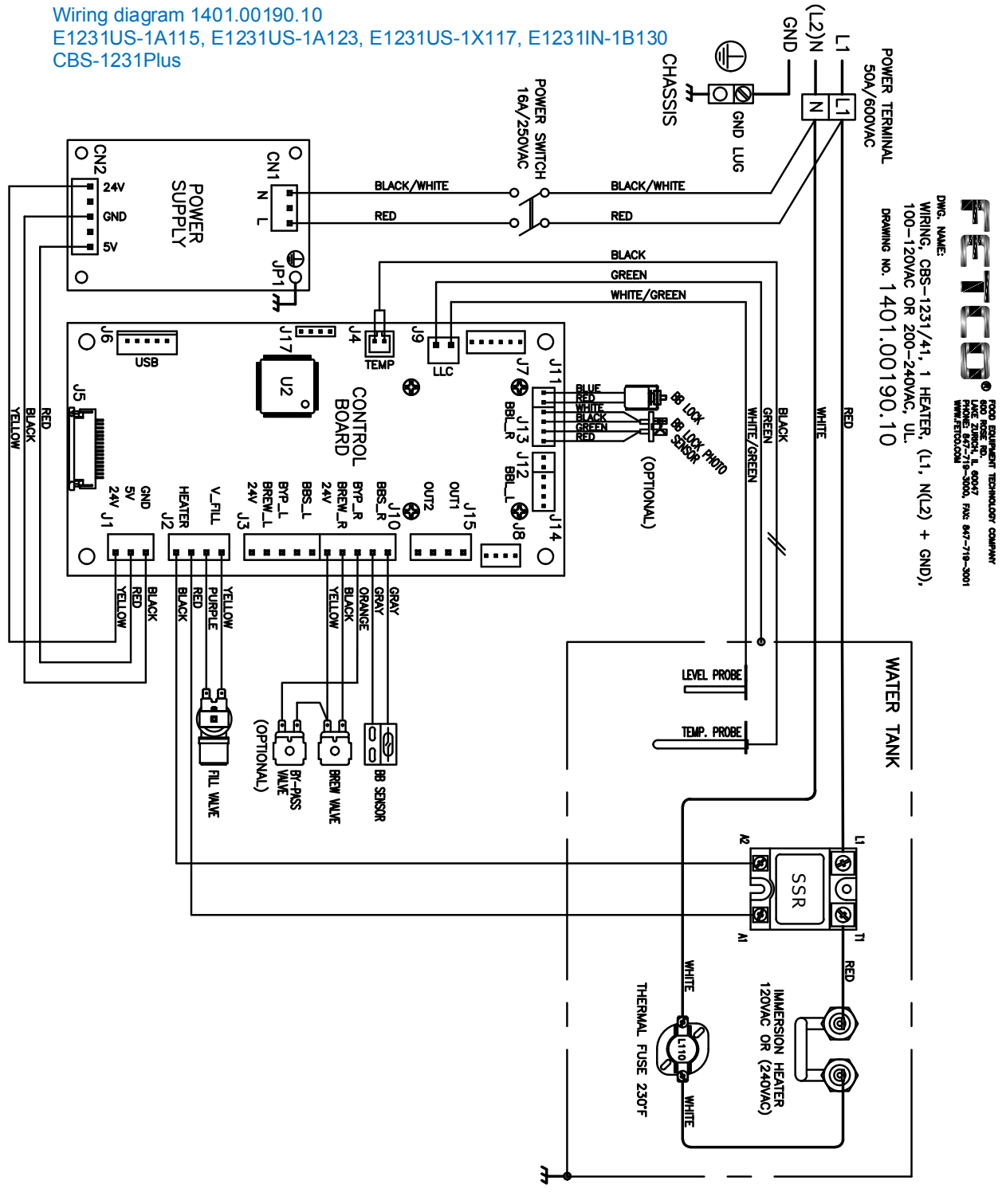

FETCO FOOD EQUIPMENT TECHNOLOGY COMPANY
 600 WEST RD.
 FORT WORTH, TX 76104
 PHONE: 817-718-3000 FAX: 817-718-3001
 WWW.FETCO.COM

DWG. NAME:
 WIRING, CBS-1231/41, 1 HEATER, (L1, N(L2) + GND),
 100-120VAC OR 200-240VAC, UL.
 DRAWING NO. 1401.00190.10

Wiring diagram 1401.00196.10
 E1232US-1B223, E1232US-1B230, E1232IN-1B223, E1232IN-1B230
 CBS-1232Plus

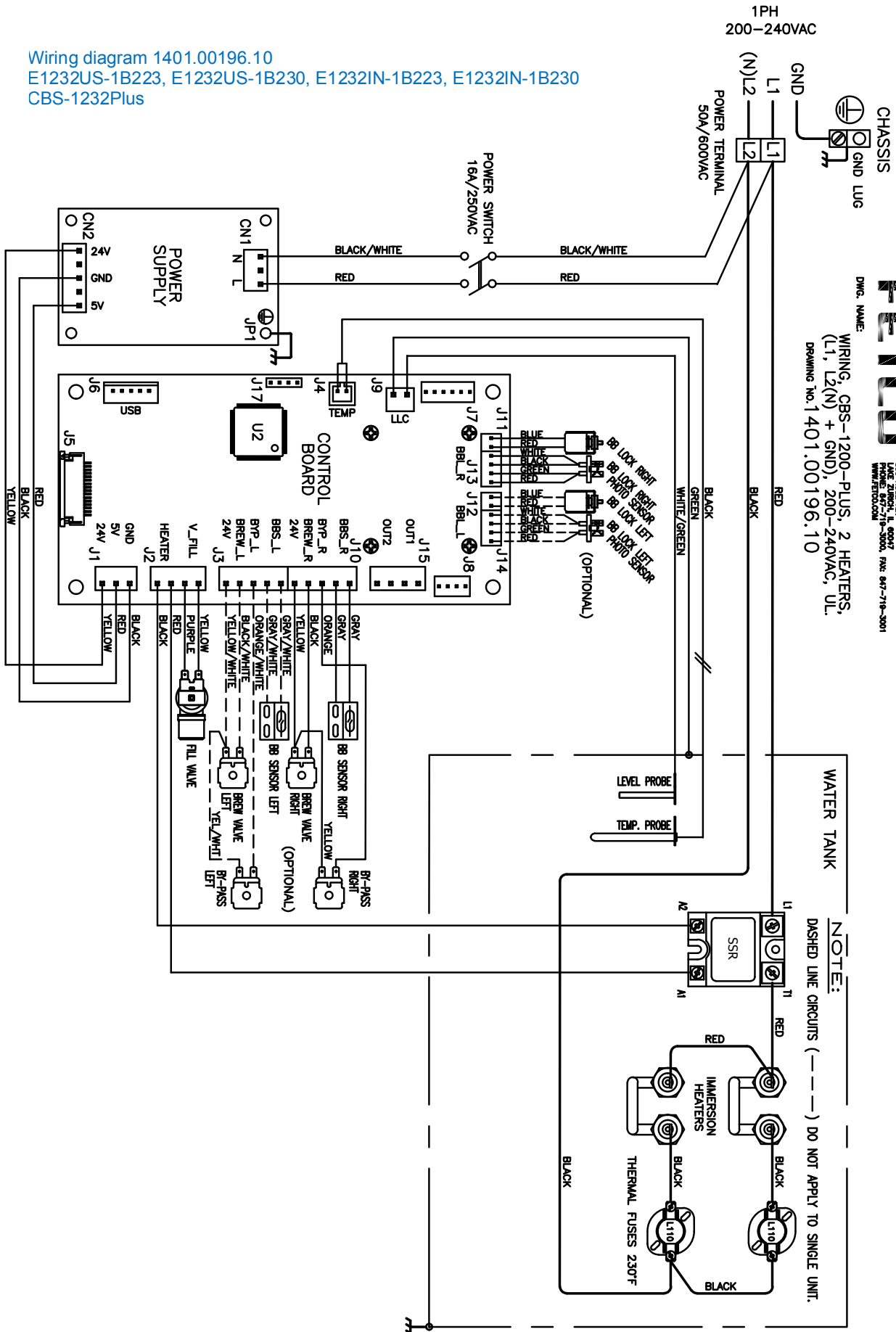

FETCO
 FOOD EQUIPMENT TECHNOLOGY COMPANY
 1400 N. 10TH ST. SUITE 100
 WISCONSIN, WI 53097
 PHONE: 847-718-3000, FAX: 847-718-3001
 WWW.FETCO.COM

DWG. NAME:
 WIRING, CBS-1200-PLUS, 2 HEATERS,
 (L1, L2(N) + GND), 200-240VAC, UL.
 DRAWING No. 1401.00196.10

NOTE:
 DASHED LINE CIRCUITS (---) DO NOT APPLY TO SINGLE UNIT.

