



**DRAPER**<sup>®</sup>

PROPANE

# SPACE HEATERS

47063, 47100, 47101 & 47105.



**IMPORTANT:** Please read these instructions carefully to ensure the safe and effective use of this product and save these instructions for future reference. This manual has been compiled by Draper Tools and is an integrated part of the product with which it is enclosed and should be kept with it for future references.

This manual describes the purpose for which the product has been designed and contains all the necessary information to ensure its correct and safe use. We recommend that this manual is read before any operation or, before performing any kind of adjustment to the product and prior to any maintenance tasks. By following all the general safety instructions contained in this manual, it will ensure both product and operator safety, together with longer life of the product itself.

All photographs and drawings in this manual are supplied by Draper Tools to help illustrate the operation of the product. Whilst every effort has been made to ensure accuracy of information contained in this manual, the Draper Tools policy of continuous improvement determines the right to make modifications without prior warning.

# 1. TITLE PAGE

---

## 1.1 INTRODUCTION:

**USER MANUAL FOR: Propane Space Heaters**

**Stock Nos:47063/47100/47101/47105**

**Part Nos: PSH10C/PSH15C/PSH30C/PSH40C**

## 1.2 REVISIONS:

**Date first published April 2018.**

---

---

---

---

As our user manuals are continually updated, users should make sure that they use the very latest version.

**Downloads are available from:** <http://drapertools.com/manuals>

Draper Tools Limited  
Hursley Road  
Chandler's Ford  
Eastleigh  
Hampshire  
SO53 1YF  
UK

**Website:** [drapertools.com](http://drapertools.com)

**Product Helpline:** +44 (0) 23 8049 4344

**General Fax:** +44 (0) 23 8026 0784

## 1.3 UNDERSTANDING THIS MANUALS SAFETY CONTENT:

**WARNING!** – Information that draws attention to the risk of injury or death.

**CAUTION!** – Information that draws attention to the risk of damage to the product or surroundings.

## 1.4 COPYRIGHT © NOTICE:

Copyright © Draper Tools Limited.

Permission is granted to reproduce this publication for personal and educational use only. Commercial copying, redistribution, hiring or lending is prohibited.

No part of this publication may be stored in a retrieval system or transmitted in any other form or means without written permission from Draper Tools Limited.

In all cases this copyright notice must remain intact.

---

# 2. CONTENTS

---

## 1. TITLE PAGE

1.1 INTRODUCTION .....	2
1.2 REVISION HISTORY .....	2
1.3 UNDERSTANDING THIS MANUAL .....	2
1.4 COPYRIGHT NOTICE.....	2

## 2. CONTENTS

2.1 CONTENTS .....	3
--------------------	---

## 3. GUARANTEE

3.1 GUARANTEE .....	4
---------------------	---

## 4. INTRODUCTION

4.1 SCOPE.....	5
4.2 SPECIFICATION .....	5
4.3 HANDLING AND STORAGE .....	5

## 5. HEALTH AND SAFETY INFORMATION

5.1 GENERAL HEATER SAFETY WARNINGS .....	6
– 1) <b>Work area safety</b> .....	6
– 2) <b>Electrical safety</b> .....	6
– 3) <b>Personal safety</b> .....	6
– 4) <b>Heater use and care</b> .....	7
– 5) <b>Service</b> .....	7
– 6) <b>Use in environments with no permanent presence of people.</b> .....	7
– 7) <b>Use in environments with permanent presence of people</b> .....	8
5.2 CONNECTION TO THE POWER SUPPLY.....	9

## 6. TECHNICAL DESCRIPTION

6.1 IDENTIFICATION .....	10
--------------------------	----

## 7. UNPACKING AND CHECKING

7.1 PACKAGING .....	11
---------------------	----

## 8. ASSEMBLING THE SPACE HEATER

8.1 GUIDELINES OF FUEL GASES .....	12
8.2 ASSEMBLING YOUR SPACE HEATER .....	12
8.3 VENTILATION .....	13
8.4 PREPARING FOR OPERATION .....	13

## 9. SPACE HEATER INSTRUCTION

9.1 VENTILATION .....	14
9.2 STARTING PROCEDURE.....	14
9.3 SHUT-DOWN PROCEDURE .....	15
9.4 SAFETY CONTROL SYSTEM .....	15

10. MAINTENANCE .....	16
-----------------------	----

11. TROUBLESHOOTING .....	17
---------------------------	----

## 12. EXPLANATION OF SYMBOLS

12.1 EXPLANATION OF SYMBOLS .....	18
-----------------------------------	----

## 13. DISPOSAL

13.1 DISPOSAL.....	19
--------------------	----

DECLARATION OF CONFORMITY .....	ENCLOSED
---------------------------------	----------

## 3. GUARANTEE

---

### 3.1 GUARANTEE

Draper tools have been carefully tested and inspected before shipment and are guaranteed to be free from defective materials and workmanship.

Should the tool develop a fault, please return the complete tool to your nearest distributor or contact:

**Draper Tools Limited, Chandler's Ford, Eastleigh, Hampshire, SO53 1YF. England.**

**Telephone Sales Desk: (023) 8049 4333** or:

**Product Helpline (023) 8049 4344.**

A proof of purchase must be provided.

If upon inspection it is found that the fault occurring is due to defective materials or workmanship, repairs will be carried out free of charge. This guarantee period covering parts/labour is 12 months from the date of purchase except where tools are hired out when the guarantee period is 90 days from the date of purchase. This guarantee does not apply to normal wear and tear, nor does it cover any damage caused by misuse, careless or unsafe handling, alterations, accidents, or repairs attempted or made by any personnel other than the authorised Draper warranty repair agent.

Note: If the tool is found not to be within the terms of warranty, repairs and carriage charges will be quoted and made accordingly.

This guarantee applies in lieu of any other guarantee expressed or implied and variations of its terms are not authorised.

Your Draper guarantee is not effective unless you can produce upon request a dated receipt or invoice to verify your proof of purchase within the guarantee period.

Please note that this guarantee is an additional benefit and does not affect your statutory rights.

**Draper Tools Limited.**

## 4. INTRODUCTION

---

### 4.1 SCOPE

This range of portable, direct fired gas heaters are designed for well ventilated industrial applications to give save, efficient and reliable operation.

### 4.2 SPECIFICATION

Stock No:	47063	47100
Part No:	PSH10C	PSH15C
Rated voltage	230V~50Hz	230V~50Hz
Rated input	30W	30W
Max. heat output	10kW/34,000BTU	15kW/50,000BTU
Air flow	300m <sup>3</sup> /h	300m <sup>3</sup> /h
Max. gas consumption	0.74kg/h	1.11kg/h
Weight (approx)	4.5kg (nett)	4.9kg (nett)
Fuel type	i3B/P	i3B/P
Regulator pressure	500mbar	700mbar
Min. gas cylinder size	15kg	15kg

Stock No:	47101	47105
Part No:	PSH30C	PSH40C
Rated voltage	230V~50Hz	230V~50Hz
Rated input	80W	80W
Max. heat output	30kW/102,000BTU	40kW/136,000BTU
Air flow	750m <sup>3</sup> /h	750m <sup>3</sup> /h
Max. gas consumption	2.2kg/h	2.9kg/h
Weight (approx)	6.7kg (nett)	7.2kg (nett)
Fuel type	i3B/P	i3B/P
Regulator pressure	1,500mbar	1,500mbar
Min. gas cylinder size	15kg	15kg

### 4.3 HANDLING AND STORAGE

The environment will have a negative result on its operation if you are not careful. If the air is damp, components will rust. If the machine is unprotected from dust and debris; components will become clogged: And if not cleaned and maintained correctly or regularly the machine will not perform at its best.

## 5. HEALTH AND SAFETY INFORMATION

---

### 5.1 GENERAL HEATER SAFETY WARNINGS

**⚠ WARNING: Read all safety warnings and all instructions.** Failure to follow the warnings and instructions may result in electric shock, fire and/or serious injury.

**Save all warnings and instructions for future reference.**

#### 1) Work area safety

- a) **Keep work area clean and well lit.** Cluttered or dark areas invite accidents.
- b) **Do not operate heaters in explosive atmospheres, such as in the presence of flammable liquids, gases or dust.** Heaters create sparks which may ignite the dust or fumes.
- c) **Keep children and bystanders away while operating a heater.** Distractions can cause you to lose control.

#### 2) Electrical safety

- a) **Heaters plugs must match the outlet. Never modify the plug in any way. Do not use any adapter plugs with earthed (grounded) heaters.** Unmodified plugs and matching outlets will reduce risk of electric shock.
- b) **Avoid body contact with earthed or grounded surfaces such as pipes, radiators, ranges and refrigerators.** There is an increased risk of electric shock if your body is earthed or grounded.
- c) **Do not expose heaters to rain or wet conditions.** Water entering a heater will increase the risk of electric shock.
- d) **Do not abuse the cord. Never use the cord for carrying, pulling or unplugging the heater. Keep cord away from heat, oil, sharp edges or moving parts.** Damaged or entangled cords increase the risk of electric shock.
- e) **When operating a heater outdoors, use an extension cord suitable for outdoor use.** Use of a cord suitable for outdoor use reduces the risk of electric shock.
- f) **If operating a heater in a damp location is unavoidable, use a residual current device (RCD) protected supply.** Use of an RCD reduces the risk of electric shock.

#### 3) Personal safety

- a) **Stay alert, watch what you are doing and use common sense when operating a heater. Do not use a heater while you are tired or under the influence of drugs, alcohol or medication. A moment of inattention while operating heaters may result in serious personal injury.**
- b) **Use personal protective equipment. Always wear eye protection.** Protective equipment such as dust mask, non-skid safety shoes, hard hat, or hearing protection used for appropriate conditions will reduce personal injuries.
- c) **Prevent unintentional starting. Ensure the switch is in the off position before connecting to power source.**
- d) **Remove any adjusting key or wrench before turning the heater on.** A wrench or a key left attached to a rotating part of the heater may result in personal injury.
- e) **Dress properly. Do not wear loose clothing or jewellery. Keep your hair, clothing and gloves away from moving parts.** Loose clothes, jewellery or long hair can get sucked into the in moving parts of the heater.

## 5. HEALTH AND SAFETY INFORMATION

---

### 4) Heater use and care

**DO NOT move the heater when it is in operation or when plugged into the mains supply. Only move heater once it has cooled and it has been unplugged.**

- a) **Use the correct heater for your application.** The correct heater will do the job better and safer at the rate for which it was designed.
- b) **Do not use the heater if the switch does not turn it on and off.** Any heater that cannot be controlled with the switch is dangerous and must be repaired.
- c) **Disconnect the plug from the power source before making any adjustments.** Such preventive safety measures reduce the risk of starting the heater accidentally.
- d) **Store idle heater out of the reach of children and do not allow persons unfamiliar with the heater or these instructions to operate the power tool.** Heaters are dangerous in the hands of untrained users.
- e) **Maintain heaters. Check for misalignment or binding of moving parts, breakage of parts and any other condition that may affect the heaters operation. If damaged, have the heater repaired before use.** Many accidents are caused by poorly maintained heaters.
- g) **Use the heater, in accordance with these instructions, taking into account the working conditions and the work to be performed.** Use of the heater for operations different from those intended could result in a hazardous situation.

### 5) Service

- a) **Have your heater serviced by a qualified repair person using only identical replacement parts.** This will ensure that the safety of the heater is maintained.

### 6) Use in environments with no permanent presence of people.

- Warning posters must be displayed prohibiting people from being permanently in that room.
- The space heaters must only be used for room drying purposes only, provided that there is a guaranteed quantity of air exchange necessary for combustion.
- The necessary quantity of air will be reached when the volume of the room (in m<sup>3</sup>) is at least 10 times the nominal calorific power (in kW) of all space heaters used in that room.
- Normal air circulation through doors and windows must be ensured.

## 5. HEALTH AND SAFETY INFORMATION

---

### 7) Use in environments with permanent presence of people.

- The space heaters can only be used in well-ventilated rooms and when the percentage of polluting substances in the air does not exceed danger levels for health.
- A good ventilation is guaranteed when the rooms volume (in m<sup>3</sup>) is at least 30 times the normal calorific power (in kW) of all machines used in that room. Openings must be also distributed in height.
- The concentration of dangerous substances in the air is acceptable until it reaches maximum levels and the percentage of oxygen in the air exceeds 17% in volume.
- The apparatus should not be used for continuous heating of stables and farms. Use of a carbon monoxide detector is recommended.

**Warning: Failure to comply with the precautions and instructions provided with this heater, can result in death, serious bodily injury and property loss or damage from hazards of fire, explosion, burn, asphyxiation, carbon monoxide poisoning, and/or electrical shock.**

- Only persons who can understand and follow the instructions should use or service this heater.
  - If you need assistance or heater information such as instructions manual, labels etc. Please contact Draper Tools.
  - Check the heater thoroughly for damage. DO NOT operate a damaged heater.
  - DO NOT modify the heater or operate a heater which has been modified from its original condition.

**Warning: We recommend the use of a carbon monoxide detector in the vicinity of the space heater.**

**Important: Not for domestic use!. Use in open buildings please abide by the relevant national and local guidelines and regulations.**

- For indoor use only. Not for use where exposed to weather.
  - Use ONLY in well ventilated areas.

**Warning: Fire, burn, inhalation and explosion hazard. Keep solid combustibles, such as building materials, paper or cardboard, a safe distance away from the heater. Never use the heater in spaces which do or may contain volatile or airborne combustibles, or products such as gasoline, solvents, paint thinner, dust particles or unknown chemicals.**

**Warning: DO NOT use ducting of any sort with this heater.**

## 5. HEALTH AND SAFETY INFORMATION

---

**Caution: Due to the high surface and exhaust temperatures, adults and children must observe clearances to avoid burns or clothing ignition. Do not touch. Keep children, clothing, and combustibles away.**

- Never point the heater directly at persons nearby. Install the heater such that it is not directly exposed to water spray, rain and / or water.
  - Never use in areas normally for habitation and /or where children may be present. Not for domestic use.
  - Operate only on a stable, level, flame proof non combustable surface.
  - Do not use in a dusty atmosphere. Never restrict or duct inlet or outlet.
  - Use only with electrical power supply specified on rating plate. The electrical connection and earthing must comply with EN 60335-1 and EN 50165
  - Use only a properly earthed socket and or extension cord.
  - Do not move, handle, or service while the heater is hot or in use.
  - Use only in accordance with national and local regulations, directives, and all other relevant restrictions.
- **WARNING:** The space heaters must only be used on fire-resistant floors. Safety distance: 2.5 metres from walls or other objects. The space heater must not be used in rooms containing explosive powders, gas fumes, flammable substances and materials. The burner must be regularly cleaned if used in dusty environments. All service operations must be carried out by duly qualified and authorised staff only.

### 5.2 CONNECTION TO THE POWER SUPPLY

**CAUTION:** Risk of electric shock. Do not open.

This appliance is supplied with a moulded 3 pin mains plug for your safety. The value of the fuse fitted is marked on the pin face of the plug. Should the fuse need replacing, ensure the substitute is of the correct rating, approved to BS1362 and ASTA or BS Kite marked.

ASTA   
BSI 

The fuse cover is removable with a small plain slot screwdriver. Ensure the fuse cover is replaced before attempting to connect the plug to an electrical outlet. If the cover is missing, a replacement must be obtained or the plug replaced with a suitable type.

If a replacement plug is to be fitted this must be carried out by a qualified electrician.

The damaged or incomplete plug, when cut from the cable shall be disabled to prevent connection to a live electrical outlet.

This appliance is Class I† and is designed for connection to a power supply matching that detailed on the rating label and compatible with the plug fitted.

If an extension lead is required, use an approved and compatible lead rated for this appliance. Follow all the instruction supplied with the extension lead.

†Earthed : This product requires an earth connection to protect against electric shock from accessible conductive parts in the event of a failure of the basic insulation.

# 6. TECHNICAL DESCRIPTION

## 6.1 IDENTIFICATION



- |                  |                        |                   |
|------------------|------------------------|-------------------|
| ① Mains plug     | ⑥ Gas control button   | ⑪ Outer shell     |
| ② Air inlet      | ⑦ Heat adjustment knob | ⑫ Hot air outlet. |
| ③ Base           | ⑧ Ignitor button       | ⑬ Gas hose        |
| ④ Gas inlet      | ⑨ Power switch         | ⑭ Gas regulator   |
| ⑤ Protection cap | ⑩ Top handle           |                   |

# 7. UNPACKING AND CHECKING

---

## 7.1 PACKAGING

Carefully remove the machine from the packaging and examine it for any sign of damage that may have happened during shipping. Lay the contents out and check them against the parts shown below. If any part is damaged or missing; please contact the Draper Helpline (the telephone number appears on the Title page) and do not attempt to use the machine.

The packaging material should be retained at least during the guarantee period: in case the machine needs to be returned for repair.

**Warning!** Some of the packaging materials used may be harmful to children. Do not leave any of these materials in the reach of children.

If any of the packaging is to be thrown away, make sure they are disposed of correctly; according to local regulations.

## 8. ASSEMBLING THE SPACE HEATER

### 8.1 GUIDELINES OF FUEL GASES

This heater is intended for the use of temporary heating of buildings under construction, alteration or repairing, in accordance with BSEN449:2002+A1:2007(E). There may also be other local standards or regulations governing the use of fuel gases and heating products, of which you can get advice from your relevant local authority.

Propane and butane belong to the odourless fuel gases family. Normally gas suppliers will add an odour-making agent to help you detect a gas leakage. However, the odour added can fade over time. Fuel gases maybe present even though no odour exists.

These heaters are intended for use with Propane (i3P) or Butane/Propane mixes (i3B/P). Any other fuel gas is considered misuse and dangerous.

To check the leakage of propane/butane please use a professional gas leakage detector or simply with soap and water solution. Never check with a flame!

Propane and butane are heavier than air. If there is a leakage, it sinks to the lowest possible level, collecting there with the surrounding air, forming a potentially explosive mixture. It is prohibited to use these gas heaters in high rise flats, bedrooms, bathrooms, basements or below ground level.

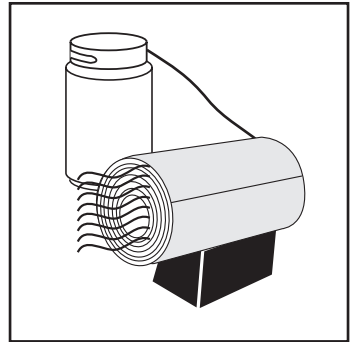

### 8.2 ASSEMBLING YOUR SPACE HEATER

1. Attach top handle to the top of the machine using screws and washers supplied.
2. Attach gas hose to gas inlet (4).

**Note:** Connections are REVERSE THREAD so they attach by turning the fixings anti-clockwise. DO NOT over-tighten.

3. Attach regulator to the other end of the gas hose.

**Warning:** DO NOT attempt to adjust regulator in any way.

4. Attach regulator to gas bottle.

## 8. ASSEMBLING THE SPACE HEATER

### 8.3 VENTILATION

**Warning:** Be sure that the heater is only ever used with correct ventilation. Make sure that no object may obstruct the fan air intake. (Fig.2.)

#### OXYGEN DELETION:

The combustion of propane will consume a lot of oxygen (with butane even more). The minimum ventilation required by these heaters is 30cm<sup>3</sup> per kW heat output is strongly recommended. Never use the heater in an enclosed space.

#### CARBON MONOXIDE (CO) POISONING:

Even though the direct-fired system of this heater operates very close to 100% combustion efficiency, it still generates small amounts of CO. Some people are more affected by CO than others. The symptoms of CO sensitivity are headache, dizziness, burning eyes and nose, nausea, dry mouth or sore throat, etc. Be sure to follow advice about ventilation.

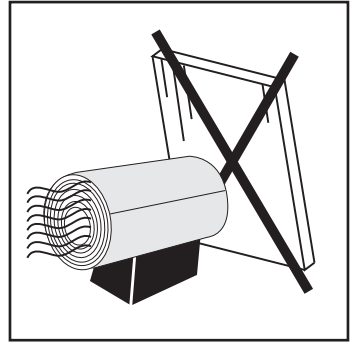

### 8.4 PREPARING FOR OPERATION

Check the heater thoroughly for damage. Do not use a damaged heater. Be sure the heating area is adequately ventilated, free of moisture and dust, far away from any combustible material. Always put the gas cylinder behind the heater in a stable position. Never put the gas cylinder in front of the heater (Fig.3.).

**Important:** Locate heater at a safe distance from any combustible materials.

Check the outlet pressure of the gas regulator and gas hose according to the specification on the rating plate. Use only BS 3016 approved gas regulator and BS 3212 approved gas hose. Gas hose should be in its natural form without excessive bending and not twisted or kinked, ensure all connections are gas tight.

**Warning:** When connecting to the gas cylinder, ensure the area is flame free to prevent risk of explosion.

Screw fasten the gas hose with regulator to the cylinder valve. Ensure the connection is tight.

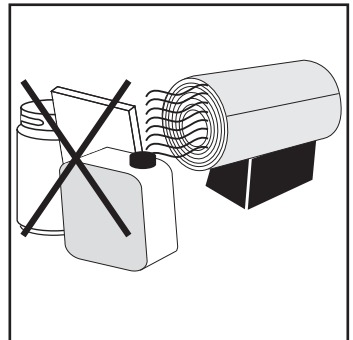
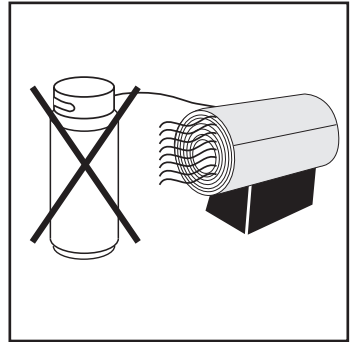

# 9. SPACE HEATER INSTRUCTION

---



## 9.1 VENTILATION

**WARNING:** PROVIDE AT LEAST A 1.5 ft<sup>2</sup> (1400 cm<sup>2</sup>) OPENING OF FRESH, OUTSIDE AIR WHILE RUNNING HEATER. IF PROPER FRESH, OUTSIDE AIR VENTILATION IS NOT PROVIDED, CARBON MONOXIDE POISONING CAN OCCUR. PROVIDE PROPER FRESH, OUTSIDE AIR VENTILATION BEFORE RUNNING HEATER

## 9.2 STARTING PROCEDURE

**WARNING:** BEFORE STARTING THE HEATER, YOU MUST ENSURE THAT THE MINIMUM VENTILATION REQUIREMENTS ARE OBSERVED TO AVOID THE RISK OF CARBON MONOXIDE POISONING.

TO START THE HEATER

1. Follow all installation, ventilation, and safety information.
2. Locate the heater on stable and level fire/flame proof surface. Make sure strong drafts do not blow into the front or rear of the heater.
3. Plug the heater into a suitable 220-240V mains socket.
4. Set the on/off switch to the on position. The motor will start, the fan will turn, forcing air from the front of the heater.
5. Open the propane supply valve on the propane tank(s) slowly.

**Note:** If not opened slowly, the excess-flow check valve on the propane tank will stop the gas flow. If this happens, close the propane supply valve and open again slowly.

**WARNING: MAKE SURE THAT THE MOTOR AND FAN ARE RUNNING BEFORE PUSHING IN AUTOMATIC CONTROL VALVE BUTTON. FLAMES COULD FLASH OUTSIDE HEATER IF THE MOTOR AND FAN ARE NOT RUNNING.**

6. Push in and hold the gas control button (6).
7. Repeatedly push the piezo ignitor button (8).
  - You may need to push the piezo ignitor button 3-8 times until the burner lights.
  - When the burner lights. keep the gas control button pushed in.
8. Release the gas control button slowly after 30 seconds.

**Note:** If the heater fails to ignite, the hose may have air in it. If so, keep the automatic control valve button pressed and wait 20 seconds. Release the automatic control valve button and wait 20 seconds for unburned fuel to exit the heater, repeat steps 6-8.

### **WARNING: EXPLOSION RISK!**

If the heater fails to start after 3 attempts, turn off the gas supply at the bottle and ventilate the area well for at least 30 minutes to remove residual gas. Then check all connections before attempting to re-start from step 1.

**Note:** If the heater is unplugged or a power outage occurs while the heater is running, the thermal limit device will stop the gas flow. A few seconds occur before the thermal limit device activates. During this short time, flames may appear outside the heater. This is normal. The flames will go out when thermal limit device activates.

## 9. SPACE HEATER INSTRUCTION

---

### 9.3 SHUT-DOWN PROCEDURE

#### TO STOP THE HEATER

1. Tightly close propane supply valve on propane tank(s).
  - Allow the heater to burn any gas left in supply hose.
2. Allow the heater to continue to run and cool down for 5 minutes, then switch off the heater.
3. Unplug the heater.

#### TO RESTART THE HEATER

1. Wait five minutes after stopping the heater.
2. Repeat steps under 'To Start The Heater'.

### 9.4 SAFETY CONTROL SYSTEM

Should the flame extinguish for any reason, the thermocouple will quickly cool, causing the Flame Failure valve to close, shutting off the gas supply. Similarly, should there be a power failure, causing the fan motor to stop, the Safety Shut-Off valve solenoid will become de-energised, and therefore shut off the gas supply.

Additionally, the machine is equipped with thermal overload protection, which will intervene should the/unit overheat shutting off the gas and electrical supply.

## 10. MAINTENANCE

---

Regular inspection and cleaning reduces the necessity for maintenance operations and will keep your heater in good working condition.

The motor must be correctly ventilated during the heater's operation. For this reason avoid blocking the air inlets.

If the replacement of the supply cord is necessary, this has to be done by the manufacturer or his agent in order to avoid a safety hazard.

Remove the plug from the socket before carrying out any adjustment, servicing or maintenance.

- Keep the heater clean, especially the motor grid and fan blades.
- Store the heater in a dry, clean and safe place away from the reach of children.
- The heater should be inspected at least once a year by a qualified person.
- Check the gas hose and its screw connections frequently.
- Repair can only be made by a suitably trained and qualified person.

# 11. TROUBLESHOOTING

Trouble	Reason	Remedy
Fan doesn't work.	<ol style="list-style-type: none"><li>1. No electricity.</li><li>2. Blade stalled by housing/ foreign body.</li></ol>	<ol style="list-style-type: none"><li>1. Check power supply.</li><li>2. Repair/replace housing.</li></ol>
Heater will not ignite.	<ol style="list-style-type: none"><li>1. Ignition cable damaged</li><li>2. Ignition cable disconnected.</li><li>3. Distance between electrode and burner too large.</li></ol>	<ol style="list-style-type: none"><li>1. Only by a qualified person.</li><li>2. Only by a qualified person.</li><li>3. Adjust distance within 3-8mm.</li></ol>
No gas.	<ol style="list-style-type: none"><li>1. Gas cylinder is empty.</li><li>2. Gas valve on cylinder closed.</li><li>3. Gas valve of heater not open.</li><li>4. Gas valve iced-up.</li></ol>	<ol style="list-style-type: none"><li>1. Replace new gas cylinder.</li><li>2. Open the valve.</li><li>3. Attempt re-light sequence correctly.</li><li>4. Use larger or multi-cylinder supply.</li></ol>
Flame goes out while heater running.	<ol style="list-style-type: none"><li>1. Thermo-element was not heated enough.</li><li>2. Safety thermo device activated.</li><li>3. Restricted air flow.</li></ol>	<ol style="list-style-type: none"><li>1. Repeat ignition process and keep safety gas valve depressed for a minimum of 30 seconds, then release slowly.</li><li>2. Allow the heater to cool down for at least 10 minutes. Check thermo device and then attempt re-light sequence correctly.</li><li>3. Check heater inlet &amp; outlet, remove any obstructions.</li></ol>

## 12. EXPLANATION OF SYMBOLS

---

### 12.1 EXPLANATION OF SYMBOLS



**Warning!**

Read the instruction manual.

# 13. DISPOSAL

---

## 13.1 DISPOSAL

- At the end of the machine's working life, or when it can no longer be repaired, ensure that it is disposed of according to national regulations.
- Contact your local authority for details of collection schemes in your area.

In all circumstances:

- Do not dispose of power tools with domestic waste.
- Do not incinerate.
- Do not abandon in the environment.
- Do not dispose of WEEE\* as unsorted municipal waste.



■  
\* Waste Electrical & Electronic Equipment.









# CONTACTS

Draper Tools Limited, Hursley Road,  
Chandler's Ford, Eastleigh, Hampshire. SO53 1YF. U.K.

Helpline: (023) 8049 4344

Sales Desk: (023) 8049 4333

Internet: [drapertools.com](http://drapertools.com)

E-mail: [sales@drapertools.com](mailto:sales@drapertools.com)

General Enquiries: (023) 8026 6355

Service/Warranty Repair Agent:

For aftersales servicing or warranty repairs, please contact the  
Draper Tools Helpline for details of an agent in your local area.

YOUR DRAPER STOCKIST

PJDH0418

©Published by Draper Tools Limited.

No part of this publication may be reproduced, stored in a retrieval system or transmitted in any form or by any means, electronic, mechanical photocopying, recording or otherwise without prior permission in writing from Draper Tools Ltd.