

CRAFTSMAN®

**3.8 Horsepower 4-Cycle Engine
21 Inch Single Stage
Auger Propelled
SNOW THROWER**

**MODEL NO.
536.885200**



Caution:

**Read and follow all Safety Rules
and Operating Instructions before
first use of this product.**

SEARS, ROEBUCK AND CO., Hoffman Estates, IL 60179 U.S.A.

F-001072M 09/01/99

SAFETY

ASSEMBLY

OPERATION

MAINTENANCE

PARTS LIST

ESPOÑOL



TABLE OF CONTENTS

WARRANTY STATEMENT	2	STORAGE	23
SAFETY RULES	3	TROUBLE SHOOTING CHART ..	24
INTERNATIONAL SYMBOLS	5	REPAIR PARTS	26
ASSEMBLY	7	ENGINE REPAIR PARTS	32
OPERATION	9	SPANISH (ESPAÑOL)	38
MAINTENANCE	15	PARTS ORDERING/SERVICE ..	
SERVICE AND ADJUSTMENT ..	18		BACK COVER

WARRANTY STATEMENT

LIMITED ONE-YEAR WARRANTY ON CRAFTSMAN SNOW THROWER

For one year from the date of purchase, when this Craftsman Snow thrower is maintained, lubricated, and tuned up according to the operating and maintenance instructions in the owner's manual, Sears will repair, free of charge, any defect in material or workmanship.

If this Craftsman Snow thrower is used for commercial or rental purposes, this warranty applies for only 90 days from the date of purchase.

This warranty does not cover the following:

- Items which become worn during normal use, such as spark plugs, drive belts and shear pins.
- Repair necessary because of operator abuse or negligence, including bent crankshafts and the failure to maintain the equipment according to the instructions contained in the owner's manual.

WARRANTY SERVICE IS AVAILABLE BY RETURNING THE CRAFTSMAN SNOW THROWER TO THE NEAREST SEARS SERVICE CENTER/DEPARTMENT IN THE UNITED STATES. THIS WARRANTY APPLIES ONLY WHILE THIS PRODUCT IS IN USE IN THE UNITED STATES.

This warranty gives you specific legal rights, and you may also have other rights which may vary from state to state.

Sears, Roebuck and Co., D817WA, Hoffman Estates. IL 60179

GENERAL RECOMMENDATIONS

The warranty on this snow thrower does not cover items that have been subjected to operator abuse or negligence. To receive full value from the warranty, the operator must maintain the snow thrower as instructed in this manual. Some adjustments will need to be made periodically to properly maintain your snow thrower.

All adjustments in the **Service and Adjustments** section of this manual must be checked at least once each season.

F-001072M

PRODUCT SPECIFICATIONS

Horse Power:	3.8
Displacement:	10 cu. in.
Fuel Tank:	1 quart
Spark Plug:	Champion RJ19LM Gap 0.030

SAFETY RULES



LOOK FOR THIS SYMBOL TO POINT OUT IMPORTANT SAFETY PRECAUTIONS. IT MEANS— ATTENTION!!! BECOME ALERT!!! YOUR SAFETY IS INVOLVED.

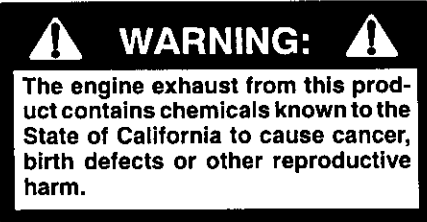

WARNING: Always disconnect the spark plug wire and place it where it cannot make contact with spark plug to prevent accidental starting during: Preparation, Maintenance, or Storage of you snow thrower.

IMPORTANT: Safety standards require operator presence controls to minimize the risk of injury. Your snow thrower is equipped with such controls. Do not attempt to defeat the function of the operator presence control under any circumstances.

TRAINING

1. Read the operating and service instruction manual carefully. Be thoroughly familiar with the controls and the proper use of the equipment. Know how to stop the unit and disengage the controls quickly.
2. Never allow children to operate the equipment. Never allow adults to operate the equipment without proper instruction.
3. Keep the area of operation clear of all persons, particularly small children and pets.
4. Exercise caution to avoid slipping or falling especially when operating in reverse.

PREPARATION

1. Thoroughly inspect the area where the equipment is to be used and remove all doormats, sleds, boards, wires, and other foreign objects.
2. Disengage all clutches before starting the engine (motor).
3. Do not operate the equipment without wearing adequate winter outer garments. Wear footwear that will improve footing on slippery surfaces.
4. Handle fuel with care; it is highly flammable.
 - a. Use an approved fuel container.

- b. Never remove fuel tank cap or add fuel to a running engine (motor) or hot engine (motor).
 - c. Fill fuel tank outdoors with extreme care. Never fill fuel tank indoors.
 - d. Replace fuel cap securely and wipe up spilled fuel.
 - e. Never store fuel or snow thrower with fuel in the tank inside of a building where fumes may reach an open flame or spark.
 - f. Check fuel supply before each use, allowing space for expansion as the heat of the engine (motor) and/or sun can cause fuel to expand.
5. For all units with electric starting motors use electric starting extension cords certified CSA/JUL. Use only with a receptacle that has been installed in accordance with local inspection authorities.
 6. Never attempt to make any adjustments while the engine (motor) is running (except when specifically recommended by manufacturer).
 7. Let engine (motor) and snow thrower adjust to outdoor temperatures before starting to clear snow.
 8. Always wear safety glasses or eye shields during operation or while performing an adjustment or repair to protect eyes from foreign objects that may be thrown from the snow thrower.

OPERATION

1. Do not operate this machine if you are taking drugs or other medication which can cause drowsiness or affect your ability to operate this machine.
2. Do not use this machine if you are mentally or physically unable to operate this machine safely.
3. Do not put hands or feet near or under rotating parts. Keep clear of the discharge opening at all times.
4. Exercise extreme caution when operating on or crossing gravel drives, walks or roads. Stay alert for hidden hazards or traffic.

5. After striking a foreign object, stop the engine (motor), remove the wire from the spark plug, thoroughly inspect snow thrower for any damage, and repair the damage before restarting and operating the snow thrower.
6. If the unit should start to vibrate abnormally, stop the engine (motor) and check immediately for the cause. Vibration is generally a warning of trouble.
7. Stop the engine (motor) whenever you leave the operating position, before unclogging the auger/impeller housing or discharge chute and when making any repairs, adjustments, or inspections.
8. When cleaning, repairing, or inspecting, make certain the auger/impeller and all moving parts have stopped and all controls are disengaged. Disconnect the spark plug wire and keep the wire away from the spark plug to prevent accidental starting.
9. Take all possible precautions when leaving the snow thrower unattended. Disengage the auger/ impeller and stop the engine (motor).
10. Do not run the engine (motor) indoors, except when starting the engine (motor) and for transporting the snow thrower in or out of the building. Open the outside doors; exhaust fumes are dangerous (containing CARBON MONOXIDE, an ODORLESS and DEADLY GAS).
11. Do not clear snow across the face of slopes. Exercise extreme caution when changing direction on slopes. Do not attempt to clear steep slopes.
12. Never operate the snow thrower without proper guards, plates or other safety protective devices in place.
13. Never operate the snow thrower near enclosures, automobiles, window wells, drop-offs, and the like without proper adjustment of the snow discharge angle. Keep children and pets away.
14. Do not overload the machine capacity by attempting to clear snow at too fast a rate.
15. Never operate the machine at high transport speeds on slippery surfaces. Look behind and use care when backing up.
16. Never direct discharge at bystanders or allow anyone in front of the unit.
17. Disengage power to the collector/impeller when snow thrower is transported or not in use.
18. Use only attachments and accessories approved by the manufacturer of the snow thrower.
19. Never operate the snow thrower without good visibility or light. Always be sure of your footing and keep a firm hold on the handles. Walk; never run.
20. Do not over-reach. Keep proper footing and balance at all times.
21. Do not attempt to use snow thrower on a roof.

MAINTENANCE AND STORAGE

1. Check bolts at frequent intervals for proper tightness to be sure the equipment is in safe working condition.
2. Never store the snow thrower with fuel in the tank inside a building where ignition sources are present such as hot water and space heaters, clothes dryers, and the like. Allow the engine (motor) to cool before storing in any enclosure.
3. Always refer to operator's guide instructions for important details if the snow thrower is to be stored for an extended period.
4. Maintain or replace safety and instruction labels, as necessary.
5. Run the snow thrower a few minutes after throwing snow to prevent freeze-up of the auger/impeller.



WARNING: This snow thrower is for use on sidewalks, driveways and other ground level surfaces.

Caution should be exercised while using on steep sloping surfaces. DO NOT USE SNOW THROWER ON SURFACES ABOVE GROUND LEVEL such as roofs of residences, garages, porches or other such structures or buildings.

SYMBOLS

IMPORTANT: Many of the following symbols are located on your unit or on literature supplied with the product. Before you operate the unit, learn and understand the purpose for each symbol.

Control And Operating Symbols

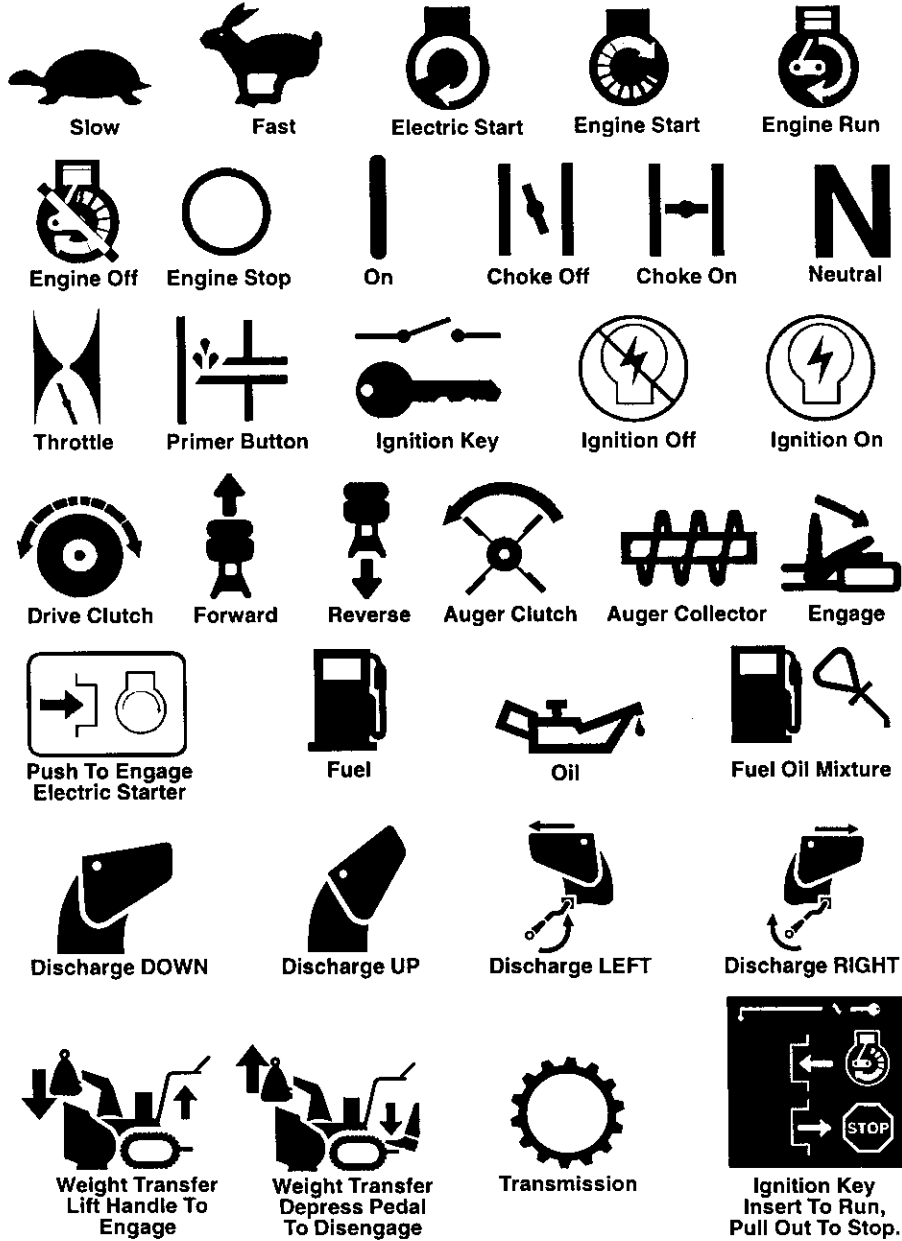

SYMBOLS

Safety Warning Symbols



DANGER
Thrown Objects.
Keep Bystanders Away.

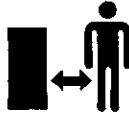

DANGER
Thrown Objects.
Keep Bystanders Away.



WARNING



IMPORTANT
Read Owner's Manual
Before Operating
This Machine.



DANGER
Avoid Injury From
Rotating Auger. Keep
Hands, Feet And
Clothing Away.

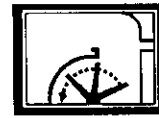

DANGER
Stop The Engine
Before Unclogging
Discharge Chute!



WARNING
Hot Surface



STOP

ASSEMBLY

Contents of Parts Bag (actual size)

- 1 – Owner's Manual (not shown)
- 1 – Packet of Fuel Stabilizer (not shown)



1– Container 5W30 Oil



WARNING: Always wear safety glasses or eye shields while assembling snow thrower.

TOOLS REQUIRED

- 1 – Knife to cut carton

Figure 1 shows the snow thrower in the operating position.

References to the right or left hand side of the snow thrower are from the viewpoint of the operator's position behind the unit.

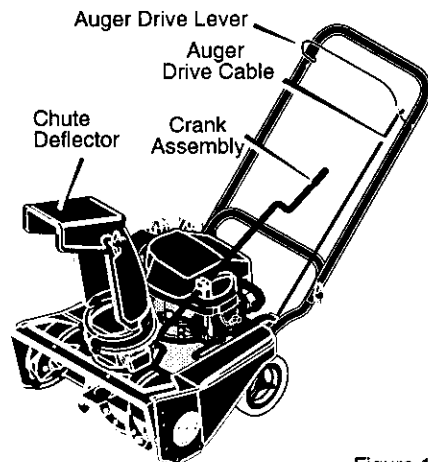

Figure 1

HOW TO REMOVE FROM THE CARTON

1. Locate and remove container of Craftsman 5W30 oil.

F-001072M

2. Locate all parts packed separately and remove from the carton.

NOTE: Place fuel stabilizer in a safe place until needed for storage.

3. Remove and discard the packing material from around the snow thrower.
4. Cut down all four corners of the carton and lay the panels flat.
5. Loosen the knobs holding the upper handle to the lower handle (See Figure 2). Raise the upper handle to the operating position. Tighten the knobs.
6. Roll snow thrower off the carton by pulling on the lower handle.
CAUTION: DO NOT back over cables.
7. Remove the packing material from handle assembly.

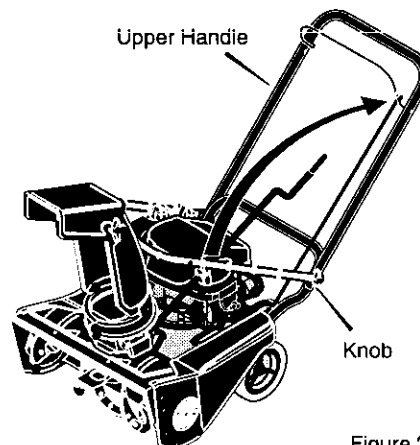

Figure 2

ASSEMBLY

✓ CHECKLIST

Before you operate your new snow thrower, to ensure that you receive the best performance and satisfaction from this quality product, please review the following checklist:

- ✓ All assembly instructions have been completed.
- ✓ The discharge chute rotates freely.
- ✓ No remaining loose parts in carton.

While learning how to use your snow thrower, pay extra attention to the following important items:

- ✓ Engine oil is at proper level.
- ✓ Make sure gas tank is filled properly with clean, fresh, unleaded gasoline.
- ✓ Become familiar with all controls—their location and function. Operate controls before starting engine.

OPERATION

KNOW YOUR SNOW THROWER

READ THIS OWNER'S MANUAL AND SAFETY RULES BEFORE OPERATING YOUR SNOW THROWER. Compare the illustrations with your SNOW THROWER to familiarize yourself with the location of various controls and adjustments. Save this manual for future reference.

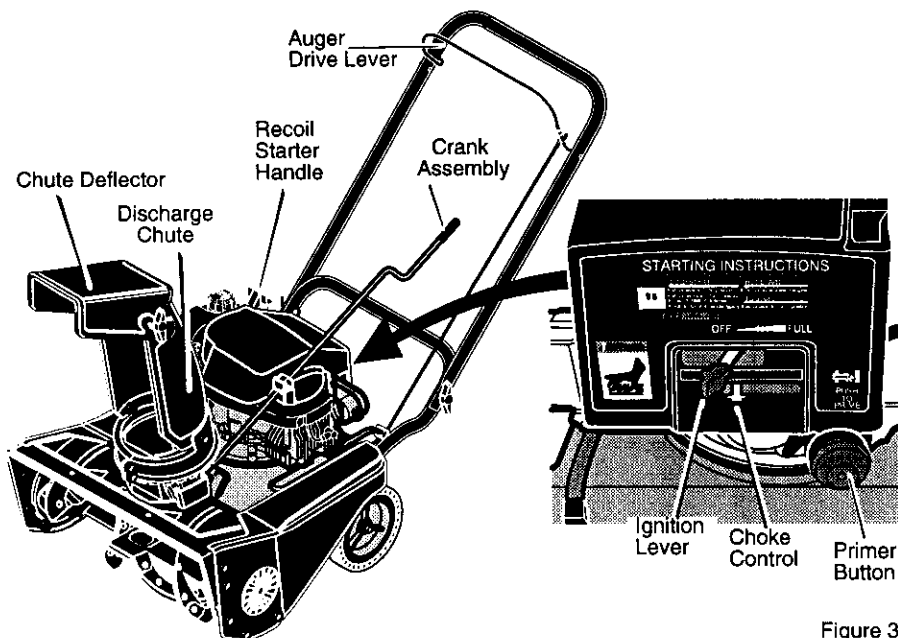

Figure 3

Auger Drive Lever – Starts and stops the auger.

Crank Assembly – Changes the direction of snow throwing through the discharge chute.

Chute Deflector – Changes the distance the snow is thrown.

Discharge Chute – Changes the direction the snow is thrown.

Ignition Lever – Must be moved to the on position to start the engine.

Recoil Starter Handle – Starts the engine manually.

Choke Control – Used to start a cold engine.

Primer Button – Injects fuel directly into the carburetor manifold for fast starts in cold weather.

OPERATION

The operation of any snow thrower can result in foreign objects being thrown into the eyes, which can result in severe eye damage. Always wear safety glasses or eye shields while operating the snow thrower.

We recommend standard safety glasses or a wide vision safety mask for over your glasses.



WARNING: Read Owner's Manual before operating machine. Never direct discharge toward bystanders stop the engine before unclogging discharge chute or auger housing and before leaving the machine.

TO STOP YOUR SNOW THROWER

1. To stop throwing snow, release the **auger drive lever**. See Figure 3.
NOTE: If the snow thrower continues to slowly move forward, see "How To Adjust The Auger Control Cable" in the Service And Adjustment Section.
2. To stop the engine, move the ignition lever to the off position.

TO CONTROL SNOW DISCHARGE

1. Turn the chute control rod to set the direction of the snow throwing.
2. Loosen the **wing knob** on the chute deflector and move the deflector to set the distance. Move the deflector (**Up**) for more distance, (**Down**) for less distance. Then tighten the **wing knob** (See Figure 4).

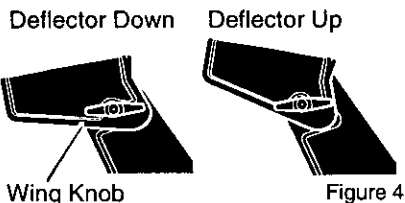

F-001072M

Figure 4

HOW TO THROW SNOW

1. Engage the **auger drive lever**.
2. To stop throwing snow, release the **auger drive lever**.



WARNING: The operation of any snow thrower can result in foreign objects being thrown into the eyes, which can result in severe eye damage. Always wear safety glasses or eye shields while operating the snow thrower. We recommend standard safety glasses or use a wide vision safety mask over your glasses.

HOW TO MOVE FORWARD

1. Hold the **auger drive lever** against the **handle** (See Figure 5). The auger will begin rotating.
2. To go forward, raise the **handle** to allow the **rubber auger blades** to contact the ground. Maintain a firm hold on the **handle** as the snow thrower starts to move forward. Guide the snow thrower by moving the **handle** either left or right. Do not attempt to push the snow thrower.
3. To stop, release the **auger drive lever**.

NOTE: If the auger continues to rotate, see "How To Adjust The Auger Control Cable" in the Service and Adjustments section.



Figure 5

OPERATION

FILL OIL:

NOTE: Engine may already contain some residual oil. Check frequently when filling the crankcase. **DO NOT** overfill.

The snow thrower was shipped with a container of 5W30 motor oil. This oil must be added to the engine before operating.

1. Remove the oil fill cap/dipstick and fill the crank case to "FULL" line on dipstick. **DO NOT** overfill. See Figure 6.
2. Tighten the fill cap/dipstick securely each time you check the oil level.

NOTE: For extreme cold operating conditions of 0°F and below, use a par-

tial synthetic 0W30 motor oil for easier starting.

NOTE: S.A.E. 5W30 motor oil may be used to make starting easier in areas where temperature is consistently 20°F or lower.

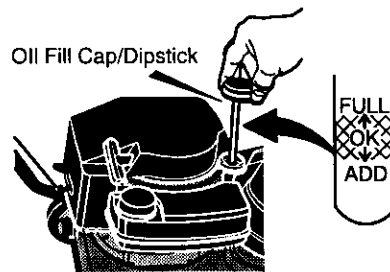

NOTE: Oil level must be between full and Add mark.

Figure 6

FILL GAS:

NOTICE: ENGINES WHICH ARE CERTIFIED TO COMPLY WITH CALIFORNIA AND US EPA EMISSION REGULATIONS FOR ULGE ENGINES: Are certified to operate on regular unleaded gasoline. Include the following emission control system(s): EM, TWC (if so equipped). Include any user adjustable features—therefore no other adjustments are needed.



WARNING: Experiences indicate that alcohol blended fuels (called gasohol or those using ethanol or methanol) can attract moisture which leads to separation and formation of acids during storage. Acidic gas can damage the fuel system of an engine while in storage.

NOTE: To avoid engine problems, the fuel system must be emptied before
F-001072M

storage for 30 days or longer. Start the engine and let it run until the fuel lines and carburetor are empty. Use the carburetor bowl drain to empty residual gasoline from the float chamber. Use fresh fuel next season. See the **Storage** section in this manual for additional information.

Never use engine or carburetor cleaner products in the fuel tank or permanent damage may occur.

1. Fill the fuel tank only with a fresh, clean, unleaded regular, unleaded premium, or reformulated automotive gasoline. **DO NOT** use leaded gasoline. Make sure that the container you pour the gasoline from is clean and free from rust or other foreign particles. Never use gasoline that may be stale from long periods of storage in the container.

OPERATION



WARNING: Gasoline is flammable. Always use caution when handling or storing

gasoline.

Do not fill fuel tank while snow thrower is running, when it is hot, or when snow thrower is in an enclosed area.

Keep away from open flame or an electrical spark and do not smoke while filling the fuel tank.

Never fill the tank completely. Fill the tank to within 1/4"–1/2" from the top to provide space for expansion of fuel.

Always fill fuel tank outdoors and use a funnel or spout to prevent spilling.

Make sure to wipe up any spilled fuel before starting the engine.

Store gasoline in a clean, approved container and keep the cap in place on the container.

BEFORE STARTING THE ENGINE

1. Before you service or start the engine, familiarize yourself with the snow thrower. Be sure you understand the function and location of all controls.
2. Be sure that all fasteners are tight.
3. Before starting the engine, make sure all controls operate correctly.

HOW TO STOP THE ENGINE

To stop the engine, move the ignition lever to the stop position.

HOW TO START THE ENGINE

(RECOIL STARTER)

Make sure that the engine has sufficient oil. The engine is equipped with a recoil starter. Before starting the engine, make certain that you have read the following information.

F-001072M

COLD START

1. Move the ignition lever to the on position.
2. Make sure the auger drive lever is in the disengaged (**RELEASED**) position.
3. Move the choke control to the full choke position.
4. Push the **primer button** while covering the vent hole as follows: Remove finger from primer button between primes.

Do not prime if temperature above 50° F (10° C).

Push two time if temperature is 50° F (10° C) to 15°F (-10° C).

Push four times if temperature is below 15° F (-10° C).

Push five time if temperature is below 0° F (-18° C).

5. Pull the **starter handle** rapidly (See Figure 7). Do not allow the handle to snap back, but allow it to rewind slowly while keeping a firm hold on the **starter handle**.

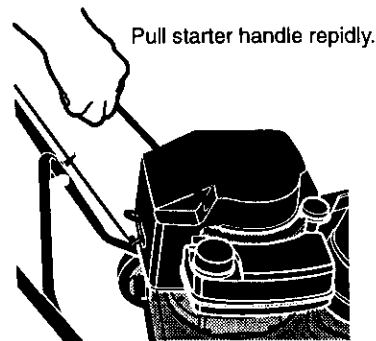

Figure 7

6. As the engine warms up, move **choke lever** to "1/2 choke" position. When engine runs smoothly, move **choke lever** to "No Choke" Position.

NOTE: Allow the engine to warm up for several minutes before blowing snow in temperatures below 0°F.

OPERATION

WARM START

If restarting a warm engine after a short shutdown, leave choke at "OFF" and do not push the primer button. If the engine fails to start, follow the Cold Start instructions.

FROZEN STARTER

If the starter is frozen and will not turn engine:

1. Pull as much rope out of the starter as possible.
2. Release the starter handle and let it snap back against the starter.

If the engine still fails to start, repeat the two previous steps until the engine starts. Then continue with the directions for cold start.

To help prevent possible freeze-up of recoil starter and engine controls, proceed as follows after each snow removal job.

1. With the engine running, pull the starter rope hard with a continuous full arm stroke three or four times. Pulling of starter rope will produce a loud clattering sound. This is not harmful to the engine or starter.
2. With the engine not running, wipe all snow and moisture from the carburetor cover in area of control levers.

Also move throttle control, choke control, and starter handle several times.



WARNING: Never run engine indoors or in enclosed, poorly ventilated areas. Engine exhaust contains CARBON MONOXIDE, AN ODORLESS AND DEADLY GAS. Keep hands, feet, hair and loose clothing away from any moving parts on engine and snow thrower.

The temperature of muffler and nearby areas may exceed 150 F. Avoid these areas.

DO NOT allow children or young teenagers to operate or be near snow thrower while it is operating.



WARNING: Do not attempt to remove any item that may become lodged in auger without taking the following precautions:

Release auger drive lever.

Move the ignition lever to the stop position to stop the engine.

Disconnect spark plug wire.

Do not place your hands in the auger or discharge chute. Use a pry bar.

SNOW THROWING TIPS

1. When the handle is raised, the auger blades will engage the ground and the snow thrower will move forward. When the auger drive lever is released, the auger blades will stop. If the blades do not stop, see "How To Adjust The Auger Drive Cable" in the Service And Adjustment section.
2. Most efficient snow throwing is accomplished when the snow is removed immediately after it falls.
3. For complete snow removal, slightly overlap each previous path.
4. Whenever possible, discharge the snow down wind.
5. The distance the snow will be discharged can be adjusted by moving the discharge chute deflector. Raise the deflector for more distance or lower the deflector for less distance.
6. In windy conditions, lower the chute deflector to direct the discharged snow close to the ground where it is less likely to blow into unwanted areas.
7. For safety and to prevent damage to the snow thrower, keep the area to be cleared free of stones, toys and other foreign objects.
8. Do not use the auger propelling feature when clearing gravel or

F-001072M

OPERATION

crushed rock driveways. Move the handle down to slightly raise the auger.

9. The forward speed of the snow thrower is dependent on the depth and weight of the snow. Experience will establish the most effective method of using the snow thrower under different conditions.
10. After each snow throwing job, allow the engine to run for a few minutes. The snow and accumulated ice will melt off the engine.
11. Clean the snow thrower after each use.
12. Remove ice, snow and debris from the entire snow thrower. Flush with water to remove all salt or other chemicals. Wipe snow thrower dry.

DRY AND AVERAGE SNOW

1. Snow up to eight inches deep can be removed rapidly and easily by walking at a moderate rate. For snow or drifts of a greater

depth, slow your pace to allow the discharge chute to dispose of the snow as rapidly as the auger receives the snow.

2. Plan to have the snow discharged in the direction the wind is blowing.

WET PACKED SNOW

Move slowly into wet, packed snow. If the wet, packed snow causes the auger to slow down or the discharge chute begins to clog, back off and begin a series of short back and forth jabs into the snow. These short back and forth jabs, four to six inches, will "belch" the snow from the chute.

SNOW BANKS AND DRIFTS

In snow of greater depth than the unit, use the same "jabbing" technique described above. Turn the discharge chute away from the snow bank. More time will be required to remove snow of this type than level snow.

MAINTENANCE

CUSTOMER RESPONSIBILITIES

SERVICE RECORDS Fill in dates as you complete regular service.	Before Each Use	Often	Every 5 Hours	Every 10 Hours	Every 25 Hours	Each Season	Before Storage	SERVICE DATES
Check Engine Oil Level	√		√			√		
Change Engine Oil					√	√		
Tighten All Screws and Nuts	√	√						
Check Spark Plug					√	√		
Lubricate Chute Control Flange							√	
Drain Fuel							√	
Check Fuel	√							
Check Auger Drive Cable Adjustment (See Cable Adjustment)						√		

GENERAL RECOMMENDATIONS

The warranty on this snow thrower does not cover items that have been subjected to operator abuse or negligence. To receive full value from the warranty, the operator must maintain the snow thrower as instructed in this manual.

Some adjustments will need to be made periodically to properly maintain your snow thrower.

All adjustments in the **Service and Adjustments** section of this manual should be checked at least once each season.

AFTER EACH USE

- Check for any loose or damaged parts.
- Tighten any loose fasteners.
- Check and maintain the auger.
- Check controls to make sure they are functioning properly.

- If any parts are worn or damaged, replace immediately.
- Run the machine to clear the auger of snow.
- To prevent freezing of the auger or controls, remove all snow and slush from the snow thrower.

LUBRICATION CHART

Lubricate chute control flange. Lubricate flange with a clinging type grease such as Lubriplate.

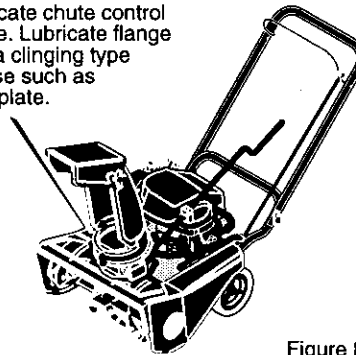

Figure 8



MAINTENANCE

HOW TO REMOVE THE TOP COVER

There are no adjustments under the top cover. If removal is required, follow the steps below.

1. Remove screws **A** that attach the rod support clamp to the top cover. Pivot crank assembly rod up and lay on unit.
2. Remove locking screw **B**.
3. Remove attachment screws **C** from lower rear edge.
4. Slide the top cover approximately 3/8 inch toward the gas tank and lift up.
5. To install the top cover, reverse the above steps.

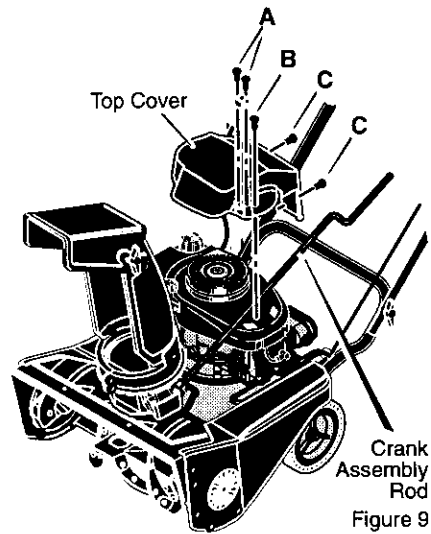

HOW TO REMOVE THE BELT COVER

1. Remove the screws **A** and nuts **B** from the belt cover.
2. Remove attachment screw **C** from the rear of the belt cover.
3. Remove the belt cover from the unit.

4. To install the belt cover, reverse the above steps.

NOTE: The belt cover has belt guides moulded onto the inside of the cover. When you install the belt cover, engage the auger drive lever to tighten the belt against the pulley. This will provide adequate clearance for the belt guides when installing the belt cover.

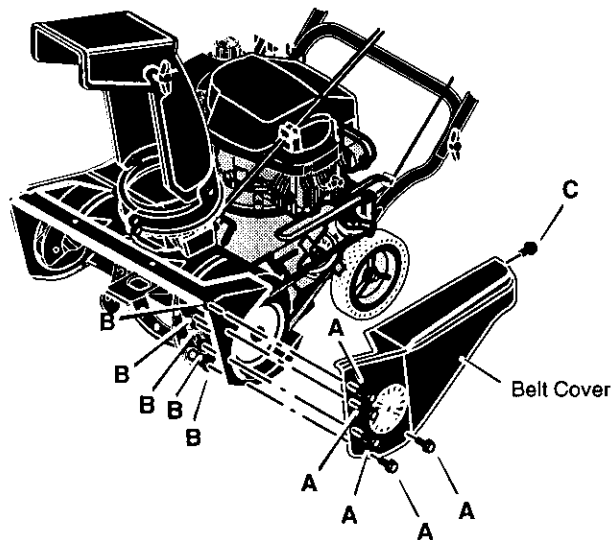

MAINTENANCE

ENGINE LUBRICATION

Check the crankcase oil level before starting the engine and after each five (5) hours of continuous use. See Figure 11. Add S.A.E. 5W30 motor oil as needed. Tighten oil fill cap/dipstick securely each time you check the oil level.

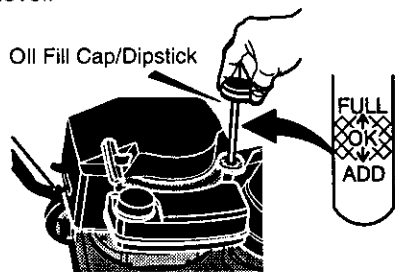

NOTE: Oil level must be between the FULL and ADD mark.

Figure 11

Change the oil every twenty-five (25) hours or at least once a year if the snow thrower is not used for twenty-five (25) hours.

HOW TO CHANGE THE ENGINE OIL

To change the engine oil, the engine must be tilted forward and the oil drained from the oil fill tube as follows.

1. Lift the rear of the snowthrower and tilt the unit forward. In the correct position, the snowthrower will be setting on the front of the auger housing.
2. Put an **oil drain pan** under the **oil fill tube** (See Figure 12).

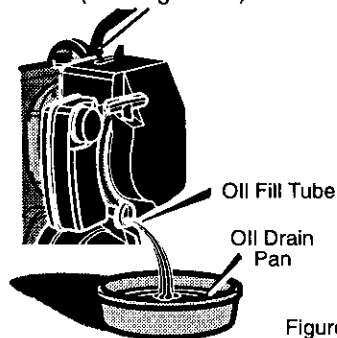

Figure 12

F-001072M

3. Carefully remove the oil fill cap/dipstick. Oil will begin to flow into the **oil drain pan**.
4. After all the oil has drained from the engine, set the snowthrower in the operating position.
5. Fill the engine with S.A.E. 5W30 oil. Make sure the oil reaches the **FULL** mark on the oil fill cap/dipstick. **DO NOT OVERFILL.**

NOTE: For extreme cold operating conditions of 0°F and below, use a partial synthetic 0W30 motor oil for easier starting.

SPARK PLUG

Check the **spark plug** every twenty-five (25) hours. Replace the **spark plug** if the electrodes are pitted or burned or if the porcelain is cracked.

1. Make sure the **spark plug** is clean. Clean the **spark plug** by carefully scraping the electrodes (**do not sand blast or use a wire brush**).
2. Check the **spark plug** gap with a **feeler gauge** and reset gap to 0.30" if necessary. See Figure 13.
3. Before installing the **spark plug**, coat the threads lightly with oil for easy removal. Tighten the spark plug to a torque of 15 foot-pounds.

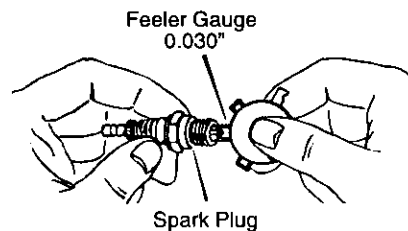

Figure 13

SERVICE AND ADJUSTMENT



WARNING: To prevent accidental starting when making any adjustments or repairs, always disconnect the spark plug wire and place it where it cannot make contact with the spark plug .

HOW TO ADJUST THE AUGER DRIVE CABLE

The auger drive cable was adjusted at the factory. If the auger will not engage or disengage correctly. Adjust the auger drive cable as follows:

1. Loosen the **nut** that holds the **cable tension spring** (See Figure 14).
2. Slide the **cable tension spring** toward the rear of the unit until all cable slack is removed.
NOTE: The **auger drive cable** is properly adjusted when the free cable slack is removed and there is no tension on the idler arm.
3. Tighten the **nut** that holds the **cable tension spring**.

If belt stretch has occurred, move the end the **auger drive cable** to the outside hole as follows:

1. Loosen the **nut** that holds the **cable tension spring** (See Figure 14).
2. Move the **cable tension spring** toward the front of the unit to achieve maximum cable slack.
3. Remove the upper end of the **auger drive cable** from the **auger drive lever**.
4. Install the **auger drive cable** in the hole shown in Figure 15.
5. Slide the **cable tension spring** toward the rear of the unit until all cable slack is removed.

NOTE: The **auger drive cable** is properly adjusted when the free cable slack is removed and there is no tension on the idler arm.

6. Tighten the **nut** that holds the **cable tension spring**.

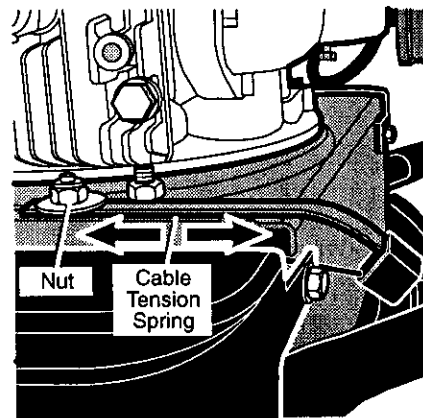

Figure 14

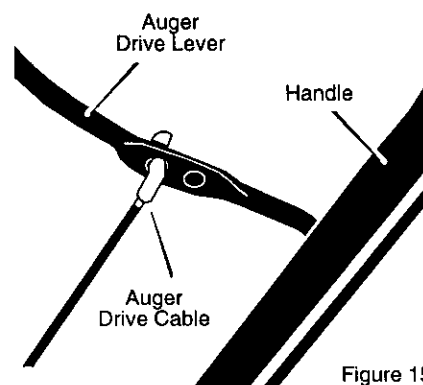

Figure 15

SERVICE AND ADJUSTMENT

HOW TO ADJUST THE AUGER BRAKE

The auger brake is adjusted at the factory to assure safe operation of the snowthrower. If the auger brake needs an adjustment, follow the steps below:

1. To access the auger brake, tilt the front of the unit up.
2. Make sure the auger drive belt is properly installed. See "How To Remove The Auger Drive Belt".
3. Make sure the auger drive lever is in the disengaged (released) position.
4. Turn the **adjuster nut** (See Figure 16) in or out until the **brake arm** is in contact with the **auger drive belt** (See Figure 17).
5. Hold the auger drive lever in the engaged position and push the **brake arm** down to remove all slack.
6. In correct adjustment, there will be **1/4 inch** clearance between the **brake arm** and the **auger drive belt** when the auger drive lever is engaged (See Figure 17).

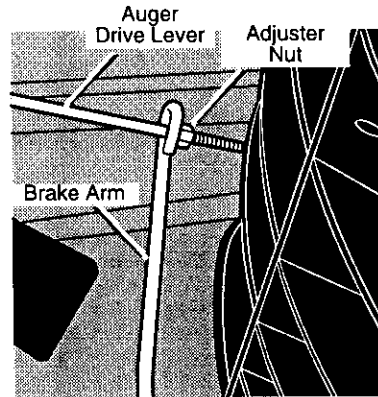

Figure 16

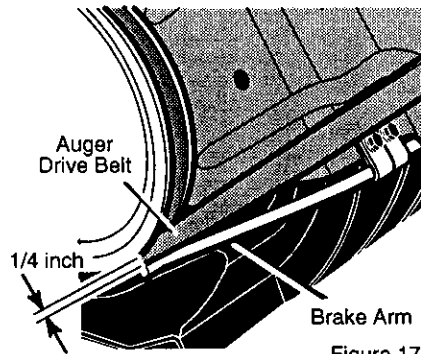

Figure 17

SERVICE AND ADJUSTMENT

HOW TO REMOVE THE AUGER DRIVE BELT

The auger drive belt is made of special construction and must be replaced with an original equipment belt available from the nearest Sears Store.

If the auger drive belt is damaged, the snowthrower will not discharge snow and will not move forward. Replace the damaged belt as follows:

1. Disconnect the spark plug wire.
2. Remove the belt cover. See "How To Remove The Belt Cover".
3. Note the path of the **auger drive belt**. For assistance, a diagram decal is provided.
4. Remove the **belt guide screw** and the **belt guide** (See Figure 18). To remove the **belt guide**, rotate the **belt guide** down.
5. Remove the **idler screw** and **idler pulley** from the **idler arm** (See Figure 19).
6. Remove the **auger drive belt** from the engine pulley and pull through side of motor box (See Figure 20).
7. To remove the **auger drive belt** from the **impeller pulley**, move the idler arm to the engaged position. This will provide **clearance** between the **impeller pulley** and the **brake arm** to remove the **auger drive belt** (See Figure 21).
8. To install a new auger drive belt, reverse the above steps.
9. Check the adjustment of the auger drive cable. See "How To Adjust The Auger Drive Cable".

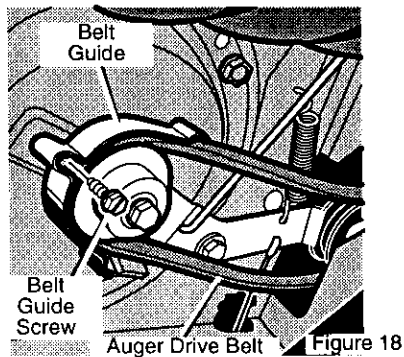

F-001072M

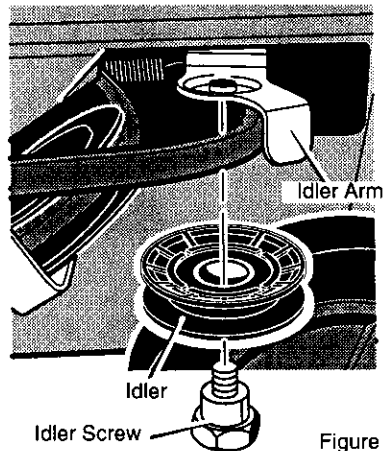

Figure 19

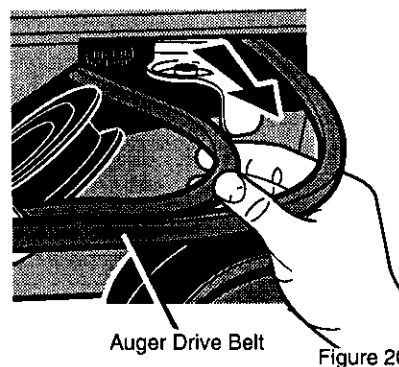

Figure 20

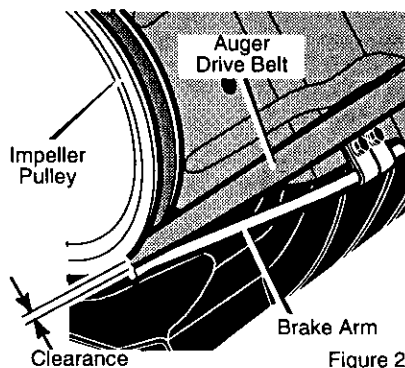

Figure 21

SERVICE AND ADJUSTMENT

HOW TO REMOVE THE AUGER

1. Remove the belt cover. See "How To Remove The Belt Cover" in the maintenance section.
2. Remove the auger drive belt. See "How To Remove The Auger Drive Belt" in the Service And Adjustment section.
3. Remove the **auger pulley** from the auger shaft (threads are left hand; turn clockwise to remove).
4. To keep the **auger** from rotating, set a 2"x4" piece of **wood** on the center **paddle** to secure **auger**.
5. Remove bolts **A**, washer **F**, and nuts **B** from front of right cover (See Figure 23).
6. Remove screw **C** from back of right cover.
7. Remove bolts **D** and nuts **E**.
8. Slide the **auger** out of the right side of the auger housing (See Figure 22).
9. Slide the **auger** out of the bearing on the left side of the auger housing.
10. To install the **auger**, reverse the above steps.

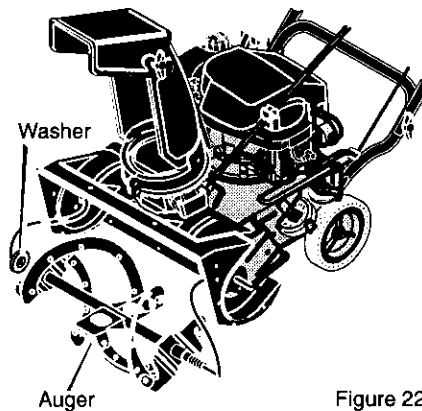

Figure 22

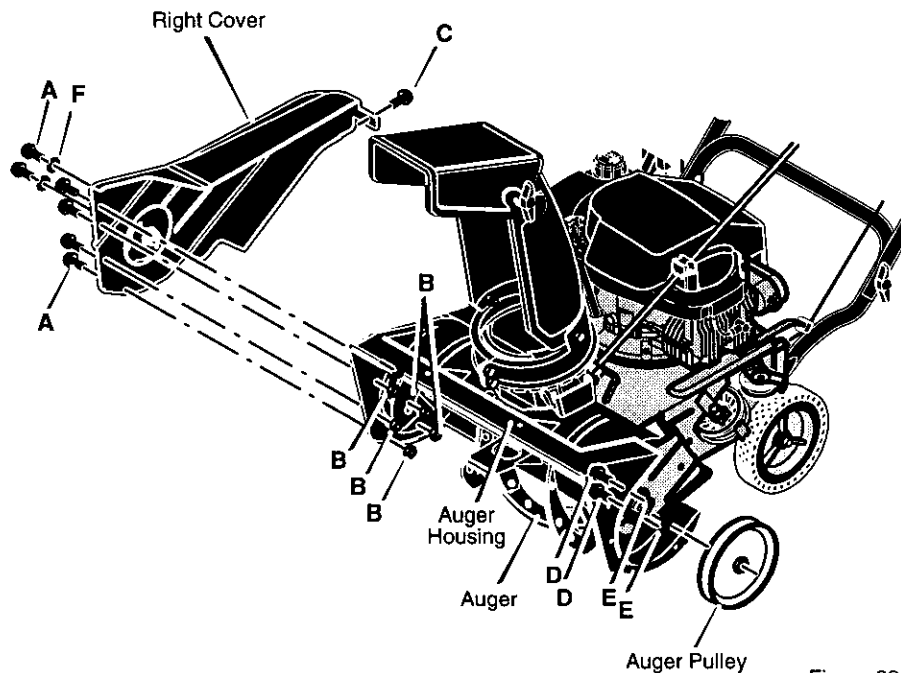

Figure 23

SERVICE AND ADJUSTMENT

TO ADJUST THE CARBURETOR

The carburetor is not adjustable. Engine performance should not be affected at altitudes up to 7,000 feet. For operation at higher elevations, contact your nearest Sears Store.

IMPORTANT: Never tamper with the engine governor, which is factory set for

proper engine speed. Over-speeding the engine above the factory high speed setting can be dangerous. If you think the engine-governed high speed needs adjusting, contact your nearest Craftsman Store, which has the proper equipment and experience to make any necessary adjustments.

TO ADJUST OR REPLACE THE SPARK PLUG

NOTE: This spark ignition system meets all requirements of the Canadian Interference-Causing Equipment Regulations.

NOTE: This engine complies with all current Australian and New Zealand limitations regarding electromagnetic interference.

If you have difficulty starting the snow thrower, adjust or replace the spark plug. Replace the spark plug if the electrodes are pitted or burned or if the porcelain is cracked. Follow the instructions below.

To adjust:

1. Clean **spark plug** by carefully

scrapping the electrodes (**Do not sand blast or use a wire brush**).

2. Be sure **spark plug** is clean and free of foreign material. Check electrodes gap with a wire **feeler gauge** and reset gap to 0.030" if necessary. See Figure 24.

To Replace:

1. If you need a new spark plug, use only the proper replacement spark plug.
2. Set the gap to 0.030 inches.
3. Before installing the spark plug, lightly coat the spark plug threads with oil or grease to insure easy removal.
4. Firmly tighten the spark plug in the engine.
5. If a torque wrench is available, torque the plug to 15 foot pounds.

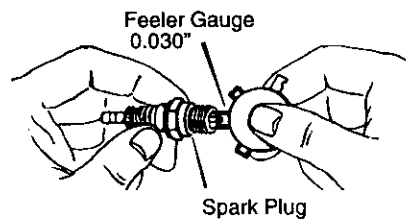

Figure 24

STORAGE



WARNING: Never store your snow thrower indoors or in an enclosed, poorly ventilated area. If gasoline remains in the tank, fumes may reach an open flame, spark or pilot light from a furnace, water heater, clothes dryer, cigarette, etc.

NOTE: To prevent engine damage (if snow thrower is not used for more than 30 days) follow the steps below.

SNOW THROWER

1. Thoroughly clean the snow thrower.
 2. Lubricate all lubrication points. See the **Maintenance** section.
 3. Be sure that all nuts, bolts and screws are securely fastened. Inspect all visible moving parts for damage, breakage and wear. Replace if necessary.
 4. Touch up all rusted or chipped paint surfaces; sand lightly before painting.
 5. Cover the bare metal parts of the blower housing auger and the impeller with rust preventative, such as a spray lubricant.
- NOTE:** A yearly checkup or tune-up by a Sears service center is a good way of ensuring that your snow thrower will provide maximum performance for the next season.

ENGINE



WARNING: Drain the gasoline outdoors, away from fire or flame.

Gasoline must be removed or treated to prevent gum deposits from forming in the fuel tank, filter, hose, and carburetor during storage. Also, during storage alcohol blended gasoline that uses ethanol or methanol (sometimes called gasohol) attracts water. It acts on the gasoline to form acids which damage the engine.

F-001072M

1. To remove gasoline, run the engine until the fuel tank is empty and the engine stops.
2. If you do not remove the gasoline, use fuel stabilizer supplied with unit or purchase Craftsman Fuel Stabilizer No. 3550. Add fuel stabilizer to any gasoline left in the tank to minimize gum deposits and acids. If the fuel tank is almost empty, mix stabilizer with fresh gasoline in a separate container and add some to the fuel tank.
3. Always follow the instruction on the stabilizer container. After the stabilizer is added to the fuel tank, run the engine at least ten minutes to allow the mixture to reach the carburetor.
4. Change the engine oil.
5. Lubricate the piston/cylinder area. First, remove the spark plug and squirt a few drops of clean engine oil into the spark plug hole. Next, cover the spark plug hole with a rag to absorb oil spray. Then, pull two or three times on the recoil starter rope to rotate the engine. Finally, install the spark plug and attach the spark plug wire.

OTHER

1. If possible, store your snow thrower indoors and cover it to give protection from dust and dirt.
2. If the machine must be stored outdoors, block up the snow thrower to be sure the entire machine is off the ground.
3. Cover the snow thrower with a suitable protective cover that does not retain moisture. Do not use plastic.

IMPORTANT: Never cover snow thrower while engine and exhaust areas are still warm.

TROUBLE SHOOTING

TROUBLE	CAUSE	CORRECTION
Difficult starting	Defective spark plug.	Replace spark plug.
	Water or dirt in fuel system.	Use carburetor bowl drain to flush and refill with fresh fuel.
Engine runs erratic	Blocked fuel line, empty gas tank, or stale gasoline.	Clean fuel line; check fuel supply; add fresh gasoline
Engine stalls	Unit running on CHOKE.	Set choke lever to run or off position.
Engine runs erratic; Loss of power	Water or dirt in fuel system.	Use carburetor bowl drain to flush and refill with fresh fuel.
Excessive vibration	Damaged auger assembly	Repair or replace the auger assembly.
Unit fails to propel itself	Drive belt loose or damaged.	Replace drive belt.
	Incorrect adjustment of auger drive cable	Adjust auger drive cable.
Unit fails to discharge snow	Auger drive belt loose or damaged.	Adjust auger drive belt; replace if damaged.
	Auger control cable not adjusted correctly.	Adjust auger control cable.
	Discharge chute clogged.	Stop engine immediately and disconnect spark plug wire. Clean discharge chute and inside of auger housing.
	Foreign object lodged in auger	Stop engine immediately and disconnect spark plug wire. Remove object from auger.

NOTES