

MULTIFUNCTION

supercook	fan assisted	classic convection	fan grill	fan forced	half fan grill	base heat	baker's function	static grill	defrost
									



finish	satin stainless steel, fingerprint proof
size	597mmH x 698mmW x 566mmD
capacity	92 litre gross; 78.7 litre net
installation	flush or proud fitment, underbench or wallmount
thermostat	50-250°C
multifunction	nine cooking functions plus defrost
programmability	24-hour digital — time of day, fully automatic, semi automatic, minute minder, manual override
cavity cooling	independent self-cooling carcass fan
furniture	<ul style="list-style-type: none"> • grill/baking tray • 2 x chrome-wire shelves • 1 x non-stick flat tray • removable roof liner • safety-grip grill tray handles
interior enamel	Ever Clean enamel
safety	thermal overload protection safety-notched furniture triple glazed door
warranty	two years parts and labour

GIANT CAPACITY

The capacity of a giant 90cm Smeg oven has been retained within a more compact 70cm format. The side fascia panels have disappeared and a new ceramic insulation is inserted between the carcass walls to eliminate heat transference to adjacent cabinetry.

SMEG THERMOSEAL

Unique to smeg is the fully sealed, non-venting oven. This sealing ensures full capacity loading, lower temperatures and faster cooking.

EVER-CLEAN ENAMEL

Smeg's enamelling process is unique, creating a silky-smooth finish on oven interiors and baking trays. A combination of formulae, coating application and firing processes creates a truly superior result. The enamel finish is pyrolytic quality and is used on all models, both standard and pyrolytic, in the range.

SELF SUFFICIENCY

The thermoseal ensures cooking does not require the addition of fluids (fats, oils) to maintain a moist cooking environment. Nor does the oven require attention — that is, turning, basting or repositioning while grilling, roasting or baking.

MAXIMUM EFFICIENCY

Sustainable lower temperatures, shorter cooking durations and higher capacities combine with virtual 'hands-free' cooking in a nonpolluting, non-venting system, delivering both a costing and lifestyle efficiency.

FULLY AUTOMATIC

The SCA709X oven can be pre-programmed to start and finish cooking. It is also semi automatic in that the cooking is started manually and then programmed to finish at a set time. There is also the 'minute minder', variable up to 23 hours and 59 minutes. This simply counts down to an audible signal with volume variability, a perfect reminder call to return to the oven for, perhaps, a cooking adjustment. These timing applications help ensure perfect cooking results and, importantly, peace of mind.

REMOVABLE ROOF LINER

Also uniquely Smeg is the removable Ever-Clean enamel roof over the grill elements. Historically this is the most inaccessible and difficult area of an oven to clean. Now, simply slide this liner out for easy wiping over or dishwasher loading.

CLEANER COOKING

Since the oven cavity is denied a vented air supply, there is reduced splatter and oxidising ('burning-on') of food particles and fluids onto interior surfaces and oven furniture.

LOW MAINTENANCE

The oven cavity is constructed of both continuous enamelled sheeting and full strip-welded panels. This, as well as ensuring the thermoseal is intact, allows for very easy access for cleaning with the absence of hidden crevices and abrupt joints.

SAFETY COOLING

An independent fan sources air from the kitchen and passes this air through the control panel and then around the carcass of the oven, exiting at the lower front of the oven back into the kitchen. The triple-glazed door, in unison with the cavity cooling system, ensures all external surfaces are safe to touch.

SCA709X

smeg 70cm electric oven, Canali design

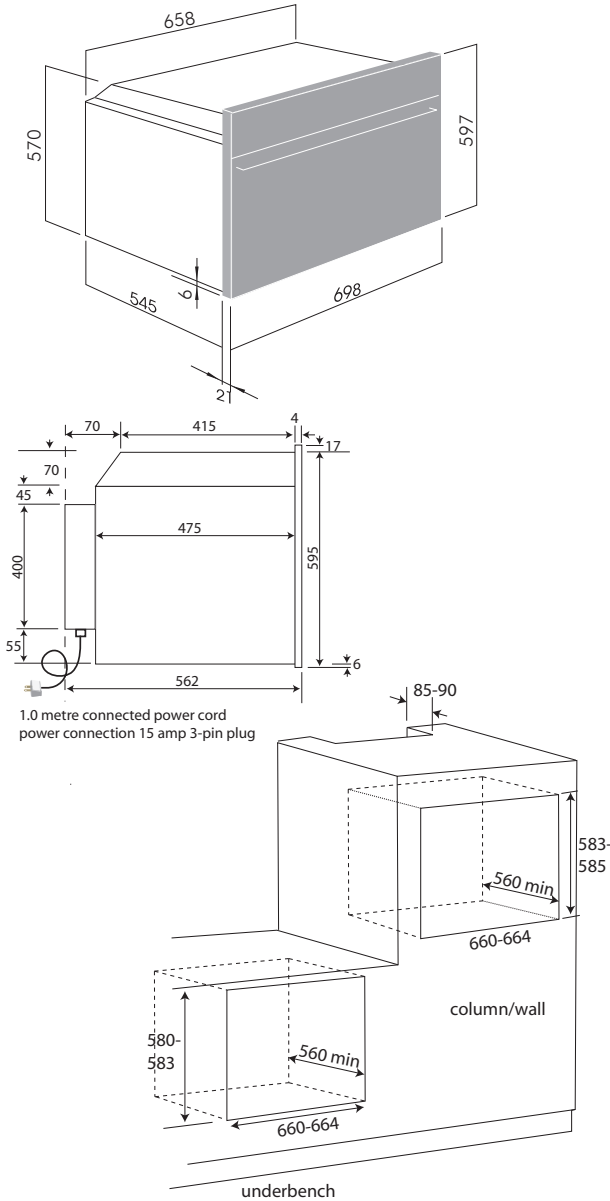

(FOR FLUSH MOUNTING, ADD MAXIMUM 4MM TO HEIGHT AND WIDTH FOR CABINET DIMENSIONS)

CUTOUT (proud mounted)

height 580-583mm
width 660-664mm
depth 560mm minimum

packaged dimensions 690mm x 760mm x 670mm = 0.35m³

net weight 44kg

gross weight 48kg

internal oven dimensions 340mmH x 615mmW x 440mmD = 92 litre

net cooking dimensions 310mmH x 605mmW x 420mmD = 78.7 litre

maximum current 13.4 amp

electricity supply 240 volt 50 Hz

electrical connection the oven has a 1.0 metre connected power cord with a three-pin plug for direct plugging to a dedicated 15 amp socket

supplied screws for mounting, instructions for installation, operation and maintenance, cookbook

NB: DRAWINGS ARE NOT TO SCALE — THEY ARE TO ASSIST ONLY.

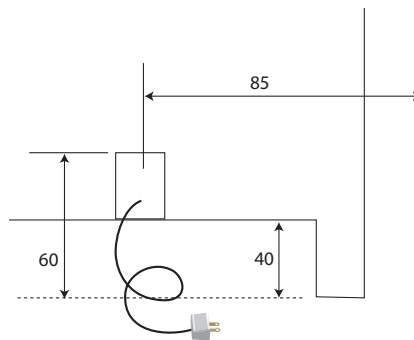

REAR ELEVATION
RIGHT-HAND CORNER

Element	Roof		Floor		Rear wall	Rear wall fan	Cooling fan	Light (2)	max watt	current amp
	inner	outer	inner	outer						
wattage	1600	1200	1200	700	2000	45	24	15 ea		
static grill	●	●					●	●	2854	11.9
bottom element			●	●			●	●	1954	8.14
half fan grill	●					●	●	●	1699	7.1
fan grill	●	●				●	●	●	2899	12.1
fan forced					●	●	●	●	2099	8.8
supercook		● 400	● 400	● 250	●	●	●	●	3149	13.2
fan assisted		●	●	●		●	●	●	3199	13.4
baker's function			●	●		●	●	●	1999	8.4
static convection		●	●	●			●	●	1999	8.4