

USER MANUAL

Mini Split Air Conditioner

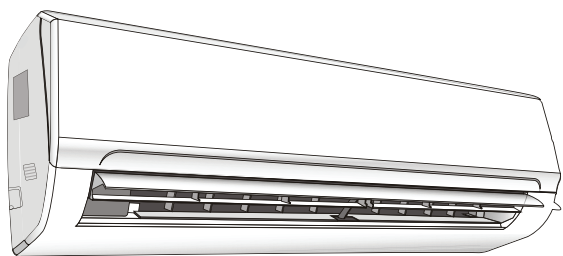

This manual applies to the following air conditioner models:

- TSHWE115-12K-32-I Indoor Unit
- TSHWE115-12K-32-O Outdoor Unit

- TSHWE230-12K-32-I Indoor Unit
- TSHWE230-12K-32-O Outdoor Unit

Please read this manual carefully before operating the device and keep it for future reference.

Message from WAYKAR

Thank you for choosing Waykar. Established with a commitment to protecting indoor climates, Waykar has grown into a leading brand in the HVAC industry, known for premium products that prioritize comfort and health in your indoor space.

Before you start exploring this product, read this manual carefully for necessary instructions first. It's advised to keep it for future reference.

24/7 Full-Time Response

Upon receipt of this AC unit, kindly inspect the package contents immediately for any potential missing or damaged parts. In case of issues, we would appreciate your prompt contact with Waykar support for solutions before initiating a return. Send us an email or scan the QR code to start a live chat.

support@waykar.com



Important: Please Read Before Usage

Ensure the air conditioner is always kept in an upright position to avoid internal damage. After unwrapping the air conditioner, please set it upright and let it sit for **24 HOURS** before plugging it in.

We may not be superheroes for life—but we can be your HERO for this AC unit. Just reach out anytime.

Not cooling down? Missing parts?
Need setup help or missed the return window?
No worries – we've got your back!

Waykar Customer Support – Available 24/7

✉ support@waykar.com 📞 (213)-895-4871



Note: The product diagrams in this manual are for illustration purposes only. The actual products may vary slightly in shape and appearance.

Table of Contents

SAFETY PRECAUTIONS.....	01
NAME OF PARTS.....	04
OPERATION INSTRUCTIONS.....	05
SERVICING SAFETY PRECAUTIONS.....	13
INSTALLATION GUIDE.....	24
TEST OPERATION.....	43
MAINTENANCE.....	45
TROUBLESHOOTING.....	46
WARRANTY & CONTACT.....	48

* The design and specifications are subject to change without prior notice for product improvement. Consult with the sales agency or manufacturer for details.

* The shape and position of buttons and indicators may vary according to the model, but their function are the same.

SAFETY PRECAUTIONS

SAFETY RULES AND RECOMMENDATIONS FOR THE INSTALLER

1. **R**ead this guide before installing and using the appliance.
2. **D**uring the installation of the indoor and outdoor units, access to the working area should be forbidden to children. Unforeseeable accidents could happen.
3. **M**ake sure that the base of the outdoor unit is firmly fixed
4. **C**heck that air cannot enter the refrigerant system and check for refrigerant leaks when turn on the air conditioner.
5. **C**arry out a test cycle after installing the air conditioner and record the operating data.
6. **P**rotect the unit with a fuse of suitable capacity for the maximum input current or with another overload protection device.
7. **E**nsure that the mains voltage corresponds to that stamped on the rating plate. Keep the switch or power terminal clean. Connect the power terminal correctly and firmly into the socket, there by avoiding the risk of electric shock or fire due to insufficient contact.
8. **T**he appliance must be equipped with devices capable of disconnection from the mains power supply, have a contact separation in all poles to provide full disconnection under "over voltage category III conditions", these devices must also be incorporated into the fixed wiring in accordance with the wiring rules.
9. **T**he air conditioner must be installed by professional or qualified persons. Do not try to install the conditioner alone, always contact specialized technical personnel.
10. **D**o not install the appliance at a distance of less than 50 cm from inflammable substances (alcohol, etc.) Or from pressurized containers (e.g. spray cans).
11. **I**f the appliance is used in areas without the possibility of ventilation, precautions must be taken to prevent any leaks of refrigerant gas from remaining in the environment and creating a danger of fire.
12. **T**he packaging materials are recyclable and should be disposed of in the separate waste bins. Take the air conditioner at the end of its useful life to a special waste collection center for disposal.
13. **O**nly use the air conditioner as instructed in this booklet. These instructions are not intended to cover every possible condition and situation. As with any electrical household appliance, common sense and caution are therefore always recommended for installation, operation and maintenance.
14. **T**he appliance must be installed in accordance with applicable national regulations.
15. **B**efore accessing the terminals, all the power circuits must be disconnected from the power supply.

SAFETY PRECAUTIONS

16. **T**his appliance can be used by children aged from 8 years and above and persons with reduced physical, sensory or mental capabilities or lack of experience and knowledge if they have been given supervision or instruction concerning use of the appliance in a safe way and understand the hazards involved. Children shall not play with the appliance. Cleaning and user maintenance shall not be made by children without supervision.
17. **C**leaning and maintenance must be carried out by specialized technical personnel. In any case disconnect the appliance from the mains electricity supply before carrying out any cleaning or maintenance.
18. **D**o not pull out the power terminal to switch off the appliance when it is in operation, since this could create a spark and cause a fire, etc.
19. **T**his appliance has been made for air conditioning domestic environments and must not be used for any other purpose, such as for drying clothes, cooling food, etc.
20. **A**lways use the appliance with the air filter mounted. Air conditioning without air filter could cause an excessive accumulation of dust and/or lead inner parts function failure.
21. **T**he user is responsible for having the appliance installed by a qualified technician, who must check that earthing/grounding is done in accordance with current legislation and insert a thermal magnetic circuit breaker.
22. **T**he batteries in the remote controller must be recycled or disposed of properly. For disposal of scrap batteries, please discard the batteries as sorted municipal waste at the accessible collection point.
23. **N**ever remain directly exposed to the flow of cold air for a long time. The direct and prolonged exposition to cold air could be dangerous for your health. Particular care should be taken in the rooms where there are children, old or sick people.
24. **I**f the appliance gives off smoke or there is a smell of burning, immediately cut off the power supply and contact the Service Center. The prolonged use of the device in such conditions could cause fire or electrocution.
25. **H**ave repairs carried out only by an authorised Service Center of the manufacturer. Incorrect repair could expose the user to the risk of electric shock, etc.
26. **U**nhook the automatic switch if you foresee not to use the device for a long time. The airflow direction must be properly adjusted.
27. **T**he flaps must be directed downwards in the heating mode and upwards in the cooling mode.
28. **E**nsure that the appliance is disconnected from the power supply when it intends to keep inoperative for a long period and before carrying out any cleaning or maintenance.
29. **S**electing the most suitable temperature can prevent damage to the appliance.

SAFETY PRECAUTIONS

1. **D**o not bend, tug or compress the power cord since this could damage it. Electrical shocks or fire are probably due to a damaged power cord. Specialized technical personnel only is recommended to replace a damaged power cord.
2. **D**o not use extensions or gang modules.
3. **D**o not touch the appliance when barefoot or parts of the body are wet or damp.
4. **D**o not obstruct the air inlet or outlet of the indoor or the outdoor unit. The obstruction of these openings causes a reduction in the operative efficiency of the conditioner with possible consequent failures or damages.
5. **I**n no way alter the characteristics of the appliance.
6. **D**o not install the appliance in environments where the air could contain flammable gas, oil or sulphur or near sources of heat.
7. **T**his appliance is not intended for use by persons (including children) with reduced physical, sensory or mental capabilities, or lack of experience and knowledge, unless they have been given supervision or instruction concerning use of the appliance by a person responsible for their safety.
8. **D**o not climb onto or place any heavy or hot objects on top of the appliance.
9. **D**o not leave windows or doors open for long when the air conditioner is operating.
10. **D**o not direct the airflow onto plants or animals.
11. **A**long direct exposition to the flow of cold air of the conditioner could have negative effects on plants and animals.
12. **D**o not put the conditioner in contact with water. The electrical insulation could be damaged and thus causing electrocution.
13. **D**o not climb onto or place any objects on the outdoor unit.
14. **N**ever insert a stick or similar object into the appliance. It could cause injury.
15. **C**hildren should be supervised to ensure that they do not play with the appliance.
16. **T**his unit is equipped with a refrigerant leak detector for safety. To be effective, the unit must be electrically powered at all times after installation, other than when servicing.
(Some models have refrigerant leak sensors, subject to the actual product received)
17. **T**his refrigerant sensor is only replaced with a manufacturer approved sensor. ~~I~~ If the sensor is replaced only as part of the component assembly, the component should be labeled.
(Some models have refrigerant leak sensors, subject to the actual product received)
18. **T**he appliance shall be installed according to the manufacturer's instructions, and) the ventilation pipe shall not exceed the maximum length and number of turns specified by the manufacturer
19. **A**ppliances shall be installed according to the instructions. Appliances that can be installed in different locations should be tested in all locations permitted by the manufacturer. The intake or exhaust openings should not be covered and the manufacturer's recommended air filter should be installed according to the instructions.
20. **A**vertissement: Avant d'accéder aux bornes de raccordement, tous les circuits d'alimentation doivent être déconnectés.

NAME OF PARTS

Indoor Unit

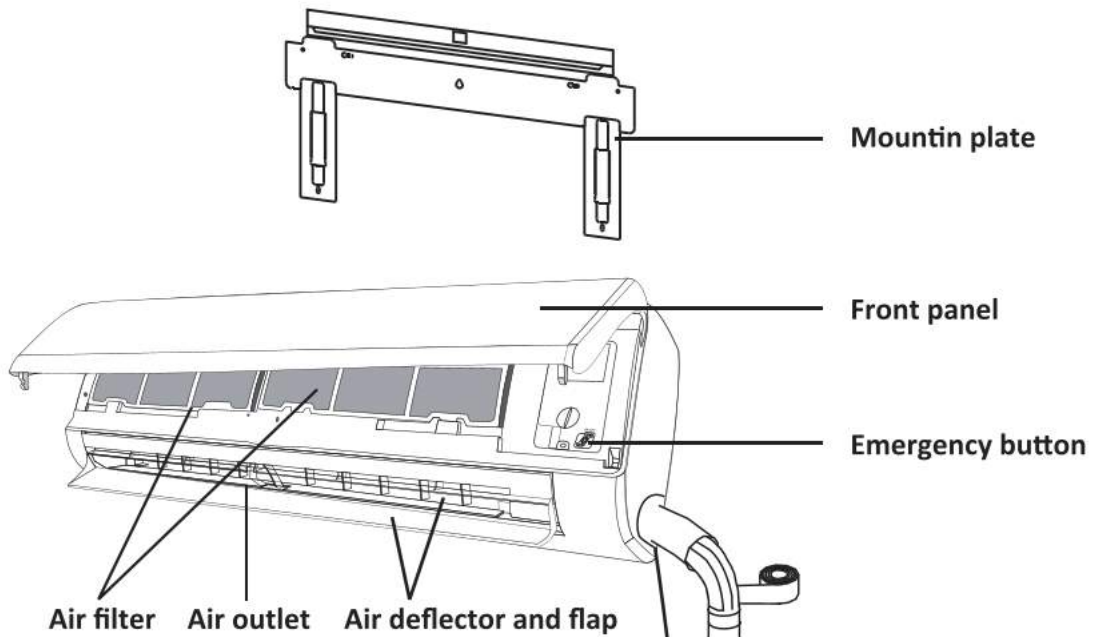

Outdoor Unit

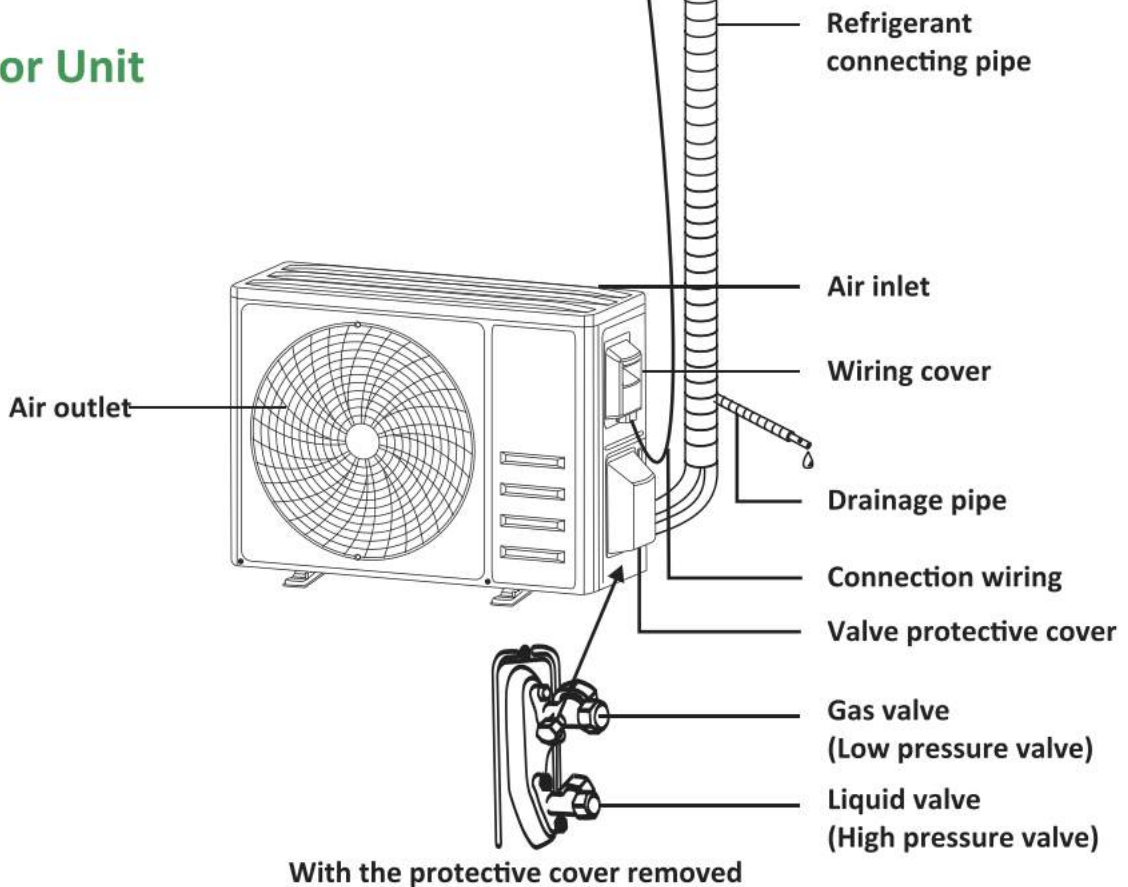

Note: This figure shown may be different from the actual object. Please take the latter as the standard.

OPERATION INSTRUCTIONS

Indoor Display



No.	LED	Function
1	00	Indicator for Timer, temperature and Error codes.
2	⏴	Lights up during Timer operation.
3	☾	SLEEP mode





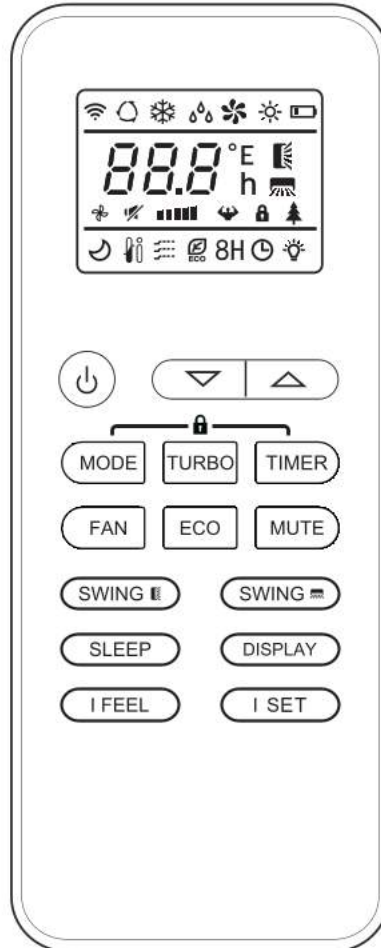

















The shape and position of switches and indicators may be different according to the model, but their function is the same.



OPERATION INSTRUCTIONS

Remote control DISPLAY, meaning of symbols on the liquid crystal display

NO.	Symbols	Meaning
1		AUTO mode indicator
2		COOLING mode indicator
3		DRY mode indicator
4		FAN mode indicator
5		HEATING mode indicator
6		BATTERY indicator
7		TEMPERATURE indicator
8		Up-down auto swing
9		Left-right auto swing
10		MUTE indicator
11		Fan speed:Auto/mute/low/mid-low/mid/mid-high/high/turbo
12		TURBO indicator
13		CHILD LOCK indicator
14		HEALTH indicator
15		SLEEP mode indicator
16		I FEEL indicator
17		GENTLE WIND indicator
18		ECO indicator
19	8H	8°C heating function indicator
20		TIMER indicator
21		DISPLAY LIGHT indicator







⚠ The display and some functions of the remote control may vary according to the model.

⚠ The shape and position of buttons and indicators may vary according to the model, but their functions are the same.

⚠ The unit confirms the correct reception of each button press with a beep.

OPERATION INSTRUCTIONS

Remote control buttons

NO.	Button	Function
1		To turn on/off the air conditioner.
2		To increase temperature, or Timer setting hours.
3		To decrease temperature, or Timer setting hours.
4	MODE	To select the operation mode: AUTO, COOL, DRY, FAN, HEAT.
5	TURBO	To activate/deactivate the TURBO function.
6	TIMER	To set the time for timer on/off.
7	FAN	To select the fan speed of auto/mute/low/mid-low/mid/mid-high/high/turbo.
8	ECO	1) To activate/deactivate the ECO function. 2) Long press to activate/deactivate the 8°C heating function (depending on models)
9	MUTE	1) To switch-on/off the MUTE function. 2) Long press to activate/deactivate the GEN function (depending on models).
10	SWING 	To stop or start horizontal flaps louver movement or set the desired up/down air flow direction.
11	SWING 	To stop or start vertical deflectors louver movement or set the desired left/right air flow direction.
12	SLEEP	To switch-on/off the function SLEEP.
13	DISPLAY	To switch-on/off the LED display.
14	I FEEL	To activate the function of I FEEL.
15	I SET	To memorize the setting temperature, setting mode and setting fan speed as you need.
16	CHILD LOCK	Press and hold both the "MODE" and "TIMER" buttons to activate/deactivate CHILD LOCK function.
17	SELF-CLEAN	While the device is off, press and hold both the "SWING 
18	GENTLE WIND	While the device is on, in COOLING mode, press and hold both the "FAN" and "MUTE" buttons simultaneously for 3 seconds to activate/deactivate the GENTLE WIND function(dependent on models).
19	HEALTH	While the device is on, press and hold both the "Sleep" and "Display" buttons simultaneously for 3 seconds to activate/deactivate the HEALTH function(dependent on models). Press the "HEALTH" buttons to activate/deactivate HEALTH function(dependent on models).

 The display and some functions of the remote control may vary according to the model.

 The shape and position of buttons and indicators may vary according to the model, but their functions are the same.

 The unit confirms the correct reception of each button press with a beep.

 Remind: Some functions may not be available on your air conditioner. If you press such a button, you can hear a beep, but the unit will not respond.

OPERATION INSTRUCTIONS

Replacement of Batteries

Remove the battery cover plate from the rear of the remote control, by sliding it in the direction as the arrow.

Install the batteries according to the direction (+ and -) shown on the Remote Control.

Reinstall the battery cover by sliding it into place.

⚠ Use 2 pieces LRO3 AAA (1.5V) batteries.

1. Do not use rechargeable batteries.
2. Replace the old batteries with new ones of the same type when the display is no longer legible.
3. Do not dispose of batteries as unsorted municipal waste.
4. Collection of such waste separately for special treatment is necessary.

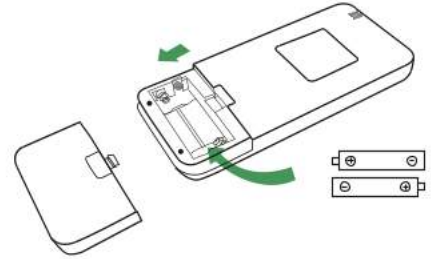

⚠ Each time when insert the batteries in the remote controller for the first time, you can set the Cooling only or Heating pump control type. As soon as you insert the batteries, turn off the remote controller, and operate as below.

1. Long press the **MODE** button, until the (❄) icon flashes, to set the Cooling only type.
2. Long press the **MODE** button, until the (🔥) icon flashes, to set the Heat pump type.

Note: If you set the remote control in cooling mode, it will not be possible to activate the heating function in units with a heating pump. If you need to reset, take out the batteries and install again.

⚠ You can program the temperature display between °C and °F.

1. Press and hold the **TURBO** button over 5 seconds to get into the change mode;
2. Press and hold the **TURBO** button, until it switches to °C and °F;
3. Then release the pressing and wait for 5 seconds, the function will be selected.

Note:

1. Direct the remote control toward the Air conditioner.
2. Check that there are no objects between the remote control and the Signal receptor in the indoor unit.
3. Never leave the remote control exposed to the rays of the sun.
4. Keep the remote control at a distance of at least 1m from the television or other electrical appliances.

OPERATION INSTRUCTIONS

COOLING MODE

COOL ❄️

The cooling function allows the air conditioner to cool the room and reduce Air humidity at the same time.

To activate the cooling function (COOL), press the **MODE** button until the symbol ❄️ appears on the display.

With the button \downarrow or \uparrow set a temperature lower than that of the room.

FAN MODE (Not FAN button)

FAN 🌀

Fan mode, air ventilation only.

To set the FAN mode, press **MODE** until 🌀 appears on the display.

DRY MODE

DRY 💧

This function reduces the humidity of the air to make the room more comfortable.

To set the DRY mode, Press **MODE** until 💧 appears in the display. An automatic function of pre-setting is activated.

AUTO MODE

AUTO 🔄

Automatic mode.

To set the AUTO mode, press **MODE** until 🔄 appears on the display.

In AUTO mode the run mode will be set automatically according to the room temperature.

HEATING MODE

HEAT ☀️

The heating function allows the air conditioner to heat the room.

To activate the heating function (HEAT), press the **MODE** button until the symbol ☀️ appears on the display.

With the button \downarrow or \uparrow set a temperature higher than that of the room.

⚠️ In HEATING operation, the appliance can automatically activate a defrost cycle, which is essential to clean the frost on the condenser so as to recover its heat exchange function. This procedure usually lasts for 2-10 minutes. During defrosting, indoor unit fan stop operation. After defrosting, it resumes to HEATING mode automatically.

⚠️ **(For North American market)**

If necessary, you can press ECO button 10 times within 8 seconds under heating mode to start the forced defrosting. It will defrost the outdoor ice much faster.

FAN SPEED function (FAN button)

FAN 🌀

Change the operating fan speed.

Press **FAN** button to set the running fan speed, it can be set to AUTO/ MUTE/ LOW/ LOW-MID / MID/ MID-HIGH/ HIGH/ TURBO speed circularly.

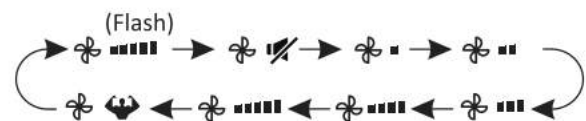

Child-Lock function

1. Long press **MODE** and **TIMER** button together to activate this function, and do it again to deactivate this function.
2. Under this function, no single button will activate.



OPERATION INSTRUCTIONS

TIMER function ---- TIMER ON

TIMER  To automatically switch on the appliance.

When the unit is switch-off, you can set the TIMER ON.

To set the time of automatic switch-on as below:

1. Press **TIMER** button first time to set the switch-on,  and  will appear on the remote display and flashes.
2. Press \wedge or \vee to button to set desired Timer-on time. Each time you press the button, the time increases/decreases by half an hour between 0 and 10 hours and by one between 10 and 24 hours.
3. Press **TIMER** button second time to confirm.
4. After Timer-on setting, set the needed mode (Cool/ Heat/ Auto/ Fan/ Dry), by press the **MODE** button. And set the needed fan speed, by press **FAN** button. And press \wedge or \vee to set the needed operation temperature.

CANCEL it by press **TIMER** button.

TIMER function ---- TIMER OFF

TIMER  To automatically switch off the appliance.

When the unit is switch-on, you can set the TIMER OFF.

To set the time of automatic switch-off, as below:





1. Confirm the appliance is ON.
2. Press the **TIMER** button at first time to set the switch-off.
Press \wedge or \vee to set the needed timer.
3. Press **TIMER** button at the second time to confirm.

CANCEL it by press **TIMER** button.

Note: All programming should be operated within 5 seconds, otherwise the setting will be cancelled.

SWING function

SWING  **SWING** 

1. Press the **SWING** button to activate the louver,
 - 1.1 Press  to activate the horizontal flaps to swing from up to down, the  will appear on the remote display.
Press again to stop the swing movement at the current angle.
 - 1.2 Press  to activate the vertical deflectors to swing from left to right, the  will appear on the remote display.
Press again to stop the swing movement at the current angle.
2. If the vertical deflectors are positioned manually which placed under the flaps, they allow to move the air flow directly to rightward or leftward.
3. For some inverter heating models, press horizontal SWING and vertical SWING together button at the same time, it will activate the Self-Clean function.

 This adjustment must be done while the appliance is switched off.

 Never position “Flaps” manually, the delicate mechanism might get seriously damaged!

 Never put fingers, sticks or other objects into the air inlet or outlet vents. Such accidental contact with live parts might cause unforeseeable damage or injury.

TURBO function

TURBO 

To activate turbo function, press the **TURBO** button, and  will appear on the display. Press again to cancel this function.

In COOL/ HEAT mode, when you select TURBO feature, the appliance will turn to quick COOL or quick HEAT mode, and operate the highest fan speed to blow strong airflow.

OPERATION INSTRUCTIONS

MUTE function



1. Press **MUTE** button to activate this function, and  will appear on the remote display. Do it again to deactivate this function.
2. When the MUTE function runs, the remote controller will display the auto fan speed, and the indoor unit will operate at lowest fan speed to help experience a quiet feeling.
3. When press FAN/ TURBO button, the MUTE function will be cancel. MUTE function can not be activated under dry mode.

SLEEP function



Pre-setting automatic operating program.

Press **SLEEP** button to activate the SLEEP function, and  appears on the display. Press again to cancel this function.

After 10 hours running in sleep mode, the air conditioner will change to the previously set mode.

I FEEL function



Press **I FEEL** button to activate the function, the  will appear on the remote display. Do it again to deactivate this function.

This function enables the remote control to measure the temperature at its current location, and send this signal to the air conditioner to optimize the temperature around you and ensure the comfort.

It will automatically deactivate 8 hours later (2hours for some modes)

I SET function



To memorize the setting temperature, setting mode, and setting fan speed as you need.

Save:

Press and hold I SET for 3 seconds to save settings. "AU" will flash.

Recall:

Press I SET to activate saved settings. "AU" will flash. Press again to cancel.

ECO function





In this mode the appliance automatically sets the operation to save energy.

Press the **ECO** button, the  appears on the display, and the appliance will run in ECO mode. Press again to cancel it.

Note: The ECO function is available in both COOLING and HEATING modes.

SELF-CLEAN function

To activate this function, turn off the indoor unit at first, then press  and  button at the same time for 3 seconds, until you hear a beep, and "AC" will appear on the remote controller display and the indoor LED display.

1. This function helps carry away the accumulated dirt, bacteria, etc from the indoor evaporator.
2. This function will run about 30 minutes, and it will return to the pre-setting mode. You can press  button to cancel this function during the process. You will hear 2 beeps when it's finished or cancelled.

 It's normal if there are some noise during this function process, as plastic materials expand with heat and contract with cold.

 We suggest operate this function as the following ambient condition to avoid certain safety.

Indoor unit	Temp < 30°C (86°F)
Outdoor unit	5°C (41°F) < Temp < 30°C (86°F)

 We suggest operating this function once every 3 months.

OPERATION INSTRUCTIONS

8°C heating function

1. Long press **ECO** button over 3 seconds to active this function, and **[8°C]** (**[46°F]**) will appear on the remote display.
Do it again to deactivate this function.
2. This function will auto start the heating mode when the room temperature is lower than 8°C (46°F), and it will return to standby if the temperature reaches 9°C (48°F).
3. If the room temperature is higher than 18°C (64°F), the appliance will cancel this function automatically.

DISPLAY function (Indoor display)

DISPLAY Switch ON/OFF the LED display on panel.

Press **DISPLAY** button to switch off the LED display on the panel. Press again to switch on the LED display.

MEMORY function

Remember your favorite setting and run into it by press One button

Remember the favorite setting:

1. In each mode (COOLING/ HEATING/ FAN/ DRY), long press " **MEMORY** " button over 3 seconds to remember it;
 2. When "AU" flashing appears on the remote controller display, that means the remote controller remember your favorite setting;
- * Press any button to quit, and you can reset it by repeat 1, 2 operation.

Run into the favorite setting:

1. In each mode (COOLING/ HEATING/ FAN/ DRY), one press " **MEMORY** " button to active;
2. The appliance will run as your favorite setting and you will see [AU] flashing on the remote controller;
3. Press it again or other buttons to cancel this function.

- ⓘ Attempt to use the air conditioner under the temperature beyond the specified range may cause the air conditioner protection device to start and the air conditioner may fail to operate. Therefore, try to use the air conditioner in the following temperature conditions.

Inverter air conditioner:

MODE	Heating	Cooling	Dry
Room temperature	0°C~27°C(32°F~80°F)	17°C~32°C(63°F~90°F)	
Outdoor temperature	-20°C~24°C(-4°F~75°F) (Low temperature heating: -20°C~24°C (-4°F~75°F))	T1 climate: 15°C~50°C(59°F~122°F) (Low temperature cooling: -15°C~50°C(5°F~122°F))	
		T3 climate: 15°C~55°C(59°F~131°F)	

With the power supply connected, restart the air conditioner after shutdown, or switch it to other mode during operation, and the air conditioner protection device will start. The compressor will resume operation after 3 minutes.

ⓘ Characteristics of heating operation (applicable to Heat pump models)

Preheating:

When the heating function is enabled, the indoor unit will take 2~5 minutes for preheating, after that the air conditioner will start heating and blows warm air.

Defrosting:

During heating, when the outdoor unit frosted, the air conditioner will enable the automatic defrosting function to improve the heating effect. During defrosting, the indoor and outdoor fans stop running. The air conditioner will resume heating automatically after defrosting finish.

ⓘ Emergency button:

Open the panel and find the emergency button on the electronic control box when the remote controller fails. (Always press the emergency button with insulation material.)

OPERATION INSTRUCTIONS

Current status	Operation	Respond	Enter mode
Standby	Press the emergency button once	It beeps briefly once.	Cooling mode
Standby (Only for Heat pump models)	Press the emergency button twice in 3 seconds	It beeps briefly twice.	Heating mode
Running	Press the emergency button once	It keeps beeping for a while	Off mode

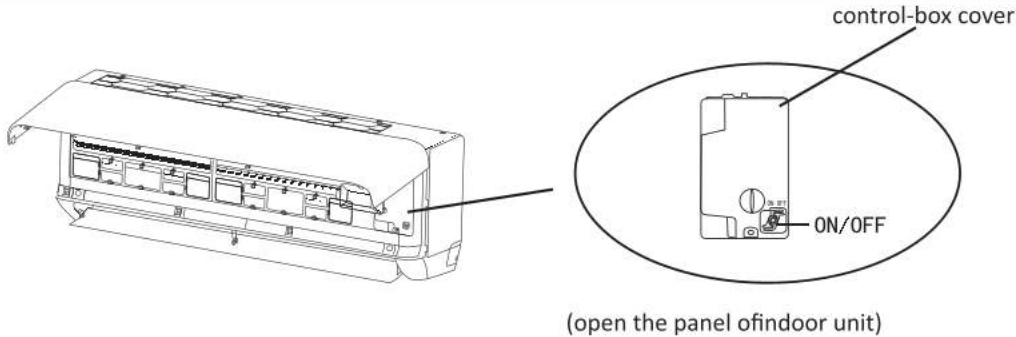

SERVICING SAFETY PRECAUTIONS

WARNING

Do not use means to accelerate the defrosting process or to clean, other than those recommended by the manufacturer.

Risk of Fire—Store in a well-ventilated room without continuously operating flames or other potential ignition. Do not pierce or burn.

Be aware that refrigerants may not contain an odour.

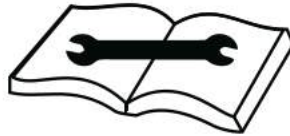
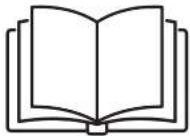

- WARNING – Risk of Fire. Flammable Refrigerant Used. To Be Repaired Only By Trained Service Personnel. Do Not Puncture Refrigerant Tubing.
- WARNING – Risk of Fire. Dispose of Properly In Accordance With Federal Or Local Regulations. Flammable Refrigerant Used.
- WARNING – Risk of Fire. Flammable Refrigerant Used. Consult Repair Manual/Owner's Guide Before Attempting To Service This Product. All Safety Precautions Must Be Followed.
- WARNING – Risk of Fire due to Flammable Refrigerant Used. Follow Handling Instructions Carefully in Compliance with National Regulations.
- WARNING – Risk of Fire – Store in a Well-Ventilated Room Without Continuously Operating Flames or Other Potential Ignition Sources.
- WARNING – Risk of Fire – The Appliance Shall Be Installed, Operated, and Stored in a Room With a Floor Area Larger Than 5 m² (54 ft²).

SERVICING SAFETY PRECAUTIONS

The area of the connected rooms, on the same floor, connected by permanent opening in the walls and/or doors between occupied spaces, including gaps between the wall and the floor can be considered a single room when determining compliance to Anvmin, provided all of the following conditions are met as fig. 2-1.

1. Low level opening

- 1) The opening shall not be less than Anvmin in Table 2-1.
- 2) The area of any openings above 11-13/16 inches from the floor shall not be considered in determining compliance with Anvmin.
- 3) At least 50% of the opening area of Anvmin shall be below 7-7/8 inches from the floor.
- 4) The bottom of the opening is not more than 3-15/16 inches from the floor.
- 5) The opening is a permanent opening that cannot be closed.
- 6) For openings extending to the floor the height shall not be less than 25/32 inches above the surface of the floor covering.

2. High level opening

- 1) The opening shall not be less than 50% of Anvmin in Table 2-1.
- 2) The opening is a permanent opening that cannot be closed.
- 3) The opening shall be at least 59 inches above the floor.
- 4) The height of the opening is not less than 25/32 inches.

NOTE:

The requirement for the second opening can be met by drop ceilings, ventilation ducts, or similar arrangements that provide an airflow path between the connected rooms.

The minimum opening for natural ventilation (Anvmin) in connected rooms is related to the room area (A), the actual refrigerant charge of refrigerant in the system (Mc), and the allowable MAXIMUM REFRIGERANT CHARGE in the system (Mmax), Anvmin can be determined according to Table 2-1.

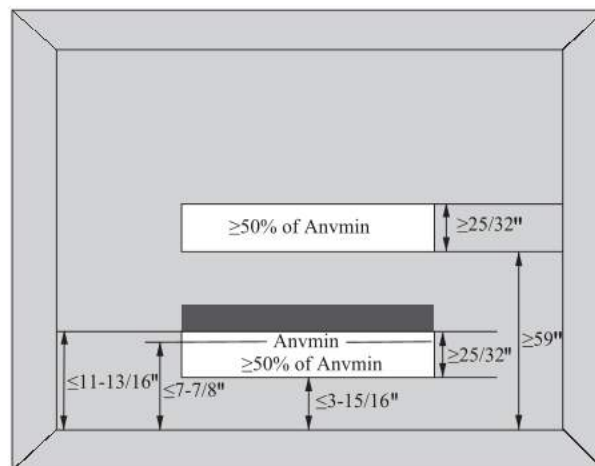

Fig.2-1 Opening Conditions for Connected Rooms

SERVICING SAFETY PRECAUTIONS

The minimum opening area for connected rooms. Note: Take the $M_c=1.73\text{kg}$ as an example.

Table 2.1

A(m ²)	Mc(kg)	Mmax(kg)	Anvmin(m ²)
4	1.73	1.48	0.0058
7	1.73	2.59	0.0000
10	1.73	3.70	0.0000
15	1.73	5.55	0.0000
20	1.73	7.4	0.0000
30	1.73	11.1	0.0000

Table GG.1 - Maximum charge (kg)

Category	LFL (kg/m ³)	h ₀ (m)	Floor area (m ²)						
			4	7	10	15	20	30	50
R32	0.306	2.5	1.53	2.68	3.83	5.51	6.36	7.79	10.06
		2.8	1.71	3.00	4.28	6.17	7.12	8.73	11.27
		3	1.84	3.21	4.59	6.61	7.63	9.35	12.07

For R32 refrigerant charge amount and minimum room area:

The machine you purchased may be one of the types in the table below. The indoor and outdoor units are designed to be used together. Please check the machine you purchased. The indoor unit should be installed at least 8.2ft /2.5m above from the floor, and the minimum room area of operating or storage should be as specified in the following table:

Table GG.2 - Minimum room area (m²)

Category	LFL (kg/m ³)	h ₀ (m)	Charge amount (M) (kg) Minimum room area (m ²)						
			0.58	0.60	1.00	1.07	1.20	1.58	2.00
R32	0.306	2.5	1.52	1.57	2.61	2.80	3.14	4.13	5.23
		2.8	1.35	1.40	2.33	2.50	2.80	3.69	4.67
		3	1.26	1.31	2.18	2.33	2.61	3.44	4.36

Refrigerant charging

Model	9K	12K	18K	24K	36K
R32(g)Standard	600	580	1070	1200	1580
R32(g)Max	675	655	1195	1325	1805

The maximum charge and the required minimum floor area

$$m_1 = (6 \text{ m}^3) \times \text{LFL}, m_2 = (52 \text{ m}^3) \times \text{LFL}, m_3 = (260 \text{ m}^3) \times \text{LFL}$$

Where LFL is the lower flammable limit in kg/ m³, R32 LFL is 0.306 kg/ m³.

For the appliances with a charge amount $m_1 < M = m_2$:

The maximum charge in a room shall be in accordance with the following:

$$M_{\max} = 2.5 \times (\text{LFL})^{(5/4)} \times h_0 \times (A)^{1/2} \text{ not to exceed } M_{\max} = \text{SF} \times \text{LFL} \times h_0 \times A \text{ (GG.3DV)}$$

The required minimum floor area A_{\min} to install an appliance with refrigerant charge M(kg) shall be in accordance with following: $A_{\min} = (M / (2.5 \times (\text{LFL})^{(5/4)} \times h_0))^2$ not less than $A_{\min} = M / (\text{SF} \times \text{LFL} \times h_0)$ (GG.4DV)

SERVICING SAFETY PRECAUTIONS

Transportation, marking and storage for units that employ flammable refrigerants

1. General

The following information is provided for units that employ FLAMMABLE REFRIGERANTS.

2. Transport of equipment containing flammable refrigerants

Attention is drawn to the fact that additional transportation regulations may exist with respect to equipment containing flammable gas. The maximum number of pieces of equipment or the configuration of the equipment permitted to be transported together will be determined by the applicable transport regulations.

3. Marking of equipment using signs

Signs for similar appliances used in a work area are generally addressed by local regulations and give the minimum requirements for the provision of safety and/or health signs for a work location. All required signs are to be maintained and employers should ensure that employees receive suitable and sufficient instruction and training on the meaning of appropriate safety signs and the actions that need to be taken in connection with these signs.

The effectiveness of signs should not be diminished by too many signs being placed together. Any pictograms used should be as simple as possible and contain only essential details.

4. Disposal of equipment using flammable refrigerants

See national regulations.

5. Storage of equipment/appliances

The storage of the appliance should be in accordance with the applicable regulations or instructions, whichever is more stringent.

6. Storage of packed (unsold) equipment

Storage package protection should be constructed in such a way that mechanical damage to the equipment inside the package will not cause a leak of the REFRIGERANT CHARGE. The maximum number of pieces of equipment permitted to be stored together will be determined by local regulations.

Requirements for operation, service and installation manuals of appliances using flammable refrigerants

Qualification of workers

The manual shall contain specific information about the required qualification of the working personnel for maintenance, service and repair operations. Every working procedure that affects safety means shall only be carried out by competent persons.

Examples for such working procedures are:

- breaking into the refrigerating circuit;
- opening of sealed components;

Competence of service personnel

1. General

Information of procedures additional to usual information for refrigerating appliance installation, repair, maintenance and decommission procedures is required when an appliance with FLAMMABLE REFRIGERANT is affected.

The training of these procedures is carried out by national training organisations or manufacturers that are accredited to teach the relevant national competency standards that may be set in legislation.

The achieved competence should be documented by a certificate.

SERVICING SAFETY PRECAUTIONS

2. Information and training

- 2.1) The training should include the substance of the following.
- 2.2) Information about the explosion potential of FLAMMABLE REFRIGERANTS to show that flammables may be dangerous when handled without care.
- 2.3) Information about POTENTIAL IGNITION SOURCES, especially those that are not obvious, such as lighters, light switches, vacuum cleaners, electric heaters.
- 2.4) Information about the different safety concepts:
 - Unventilated-Safety of the appliance does not depend on ventilation of the housing.
 - Switching off the appliance or opening of the housing has no significant effect on the safety.
 - Nevertheless, it is possible that leaking refrigerant may accumulate inside the enclosure and flammable atmosphere will be released when the enclosure is opened.
 - Ventilated enclosure-Safety of the appliance depends on ventilation of the housing.
 - Switching off the appliance or opening of the enclosure has a significant effect on the safety.
 - Care should be taken to ensure sufficient ventilation before.
 - Ventilated room -Safety of the appliance depends on the ventilation of the room.
 - Switching off the appliance or opening of the housing has no significant effect on the safety.
 - The ventilation of the room shall not be switched off during repair procedures.
- 2.5) Information about refrigerant detectors:
 - Principle of function, including influences on the operation.
 - Procedures, how to repair, check or replace a refrigerant detector or parts of it in a safe way.
 - Procedures, how to disable a refrigerant detector in case of repair work on the refrigerant carrying parts.
- 2.6) Information about the concept of sealed components and sealed enclosures according to IEC60079-15:2010.
- 2.7) Information about the correct working procedures:
 - a) Commissioning
 - Ensure that the floor area is sufficient for the REFRIGERANT CHARGE or that the ventilation duct is assembled in a correct manner.
 - Connect the pipes and carry out a leak test before charging with refrigerant.
 - Check safety equipment before putting into service.
 - b) Maintenance
 - Portable equipment shall be repaired outside or in a workshop specially equipped for servicing units with FLAMMABLE REFRIGERANTS.
 - Ensure sufficient ventilation at the repair place.
 - Be aware that malfunction of the equipment may be caused by refrigerant loss and a refrigerant leak is possible.
 - Discharge capacitors in a way that won't cause any spark. The standard procedure to short circuit the capacitor terminals usually creates sparks.
 - Reassemble sealed enclosures accurately. If seals are worn, replace them.
 - Check safety equipment before putting into service.
 - c) Repair
 - Portable equipment shall be repaired outside or in a workshop specially equipped for servicing units with FLAMMABLE REFRIGERANTS.
 - Ensure sufficient ventilation at the repair place.
 - Be aware that malfunction of the equipment may be caused by refrigerant loss and a refrigerant leak is possible.

SERVICING SAFETY PRECAUTIONS

- Discharge capacitors in a way that won't cause any spark.
- When brazing is required, the following procedures shall be carried out in the right order: Remove the refrigerant. If the recovery is not required by national regulations, drain the refrigerant to the outside. Take care that the drained refrigerant will not cause any danger. In doubt, one person should guard the outlet. Take special care that drained refrigerant will not float back into the building.

--Evacuate the refrigerant circuit.

--Purge the refrigerant circuit with nitrogen for 5 min (not required for A2L REFRIGERANTS).

--Evacuate again (not required for A2L REFRIGERANTS).

--Remove parts to be replaced by cutting, not by flame.

--Purge the braze point with nitrogen during the brazing procedure.

--Carry out a leak test before charging with refrigerant.

- Reassemble sealed enclosures accurately. If seals are worn, replace them.

- Check safety equipment before putting into service.

d) Disposal

- Ensure sufficient ventilation at the working place.

- Remove the refrigerant. If the recovery is not required by national regulations, drain the refrigerant to the outside. Take care that the drained refrigerant will not cause any danger. In doubt, one person should guard the outlet. Take special care that drained refrigerant will not float back into the building.

- When flammable refrigerants are used,

--evacuate the refrigerant circuit.

--purge the refrigerant circuit with oxygen free nitrogen.

--evacuate again. (not required for A2L refrigerants);

--cut out the compressor and drain the oil.

Information on servicing

1. General

The manual shall contain specific information for service personnel according.

2. Checks to the area

Prior to beginning work on systems containing FLAMMABLE REFRIGERANTS, safety checks are necessary to ensure that the risk of ignition is minimised.

For repair to the REFRIGERATING SYSTEM

3. Work procedure

Work shall be undertaken under a controlled procedure so as to minimise the risk of a flammable gas or vapour being present while the work is being performed.

4. General work area

All maintenance staff and others working in the local area shall be instructed on the nature of work being carried out. Work in confined spaces shall be avoided.

5. Checking for presence of refrigerant

The area shall be checked with an appropriate refrigerant detector prior to and during work, to ensure the technician is aware of potentially toxic or flammable atmospheres. Ensure that the leak detection equipment being used is suitable for use with all applicable refrigerants, i. e. non-sparking, adequately sealed or intrinsically safe.

SERVICING SAFETY PRECAUTIONS

6. Presence of fire extinguisher

If any hot work is to be conducted on the refrigerating equipment or any associated parts, appropriate fire extinguishing equipment shall be available to hand. Have a dry powder or CO₂ fire extinguisher adjacent to the charging area.

a) Commissioning

- Ensure that the floor area is sufficient for the REFRIGERANT CHARGE or that the ventilation duct is assembled in a correct manner.
- Connect the pipes and carry out a leak test before charging with refrigerant.
- Check safety equipment before putting into service.

b) Maintenance

- Portable equipment shall be repaired outside or in a workshop specially equipped for servicing units with FLAMMABLE REFRIGERANTS.
- Ensure sufficient ventilation at the repair place.
- Be aware that malfunction of the equipment may be caused by refrigerant loss and a refrigerant leak is possible.
- Discharge capacitors in a way that won't cause any spark. The standard procedure to short circuit the capacitor terminals usually creates sparks.
- Reassemble sealed enclosures accurately. If seals are worn, replace them.
- Check safety equipment before putting into service.

c) Repair

- Portable equipment shall be repaired outside or in a workshop specially equipped for servicing units with FLAMMABLE REFRIGERANTS.
- Ensure sufficient ventilation at the repair place.
- Be aware that malfunction of the equipment may be caused by refrigerant loss and a refrigerant leak is possible.
- Discharge capacitors in a way that won't cause any spark.
- When brazing is required, the following procedures shall be carried out in the following order:
 - Safely remove the refrigerant following local and national regulations. If the recovery is not required by national regulations, drain the refrigerant to the outside. Take care that the drained refrigerant will not cause any danger. In doubt, one person should guard the outlet. Take special care that drained refrigerant will not float back into the building;

d) Decommissioning

- If the safety is affected when the equipment is putted out of service, the REFRIGERANT CHARGE shall be removed before decommissioning.
- Ensure sufficient ventilation at the equipment location.
- Be aware that malfunction of the equipment may be caused by refrigerant loss and a refrigerant leak is possible.
- Discharge capacitors in a way that won't cause any spark.
- Remove the refrigerant. If the recovery is not required by national regulations, drain the refrigerant to the outside. Take care that the drained refrigerant will not cause any danger. In doubt, one person should guard the outlet. Take special care that drained refrigerant will not float back into the building.
- When FLAMMABLE REFRIGERANTS except A2L REFRIGERANTS are used,
 - Evacuate the refrigerant circuit.

SERVICING SAFETY PRECAUTIONS

7. No ignition sources

No person carrying out work in relation to a REFRIGERATING SYSTEM which involves exposing any pipe work shall use any sources of ignition in such a manner that it may lead to the risk of fire or explosion. All possible ignition sources, including cigarette smoking, should be kept sufficiently far away from the site of installation, repairing, removing and disposal, during which refrigerant can possibly be released to the surrounding space. Prior to work taking place, the area around the equipment is to be surveyed to make sure that there are no flammable hazards or ignition risks. "No Smoking" signs shall be displayed.

8. Ventilated area

Ensure that the area is in the open or that it is adequately ventilated before breaking into the system or conducting any hot work. A degree of ventilation shall continue during the period that the work is carried out. The ventilation should safely disperse any released refrigerant and preferably expel it externally into the atmosphere.

9. Checks to the refrigerating equipment

Where electrical components are being changed, they shall be fit for the purpose and to the correct specification. At all times the manufacturer's maintenance and service guidelines shall be followed. If in doubt, consult the manufacturer's technical department for assistance.

The following checks shall be applied to installations using.

FLAMMABLE REFRIGERANTS:

- the actual REFRIGERANT CHARGE is in accordance with the room size within which the refrigerant containing parts are installed;
- the ventilation machinery and outlets are operating adequately and are not obstructed;
- if an indirect refrigerating circuit is being used, the secondary circuit shall be checked for the presence of refrigerant;
- marking to the equipment continues to be visible and legible. Markings and signs that are illegible shall be corrected;
- refrigerating pipe or components are installed in a position where they are unlikely to be exposed to any substance which may corrode refrigerant containing components, unless the components are constructed of materials which are inherently resistant to being corroded or are suitably protected against being so corroded.

10. Checks to electrical devices

Repair and maintenance to electrical components shall include initial safety checks and component inspection procedures. If a fault exists that could compromise safety, then no electrical supply shall be connected to the circuit until it is satisfactorily dealt with. If the fault cannot be corrected immediately but it is necessary to continue operation, an adequate temporary solution shall be used. This shall be reported to the owner of the equipment so all parties are advised.

Initial safety checks shall include:

- that capacitors are discharged: this shall be done in a safe manner to avoid possibility of sparking;
- that no live electrical components and wiring are exposed while charging, recovering or purging the system;
- that there is continuity of earth bonding.

SERVICING SAFETY PRECAUTIONS

11. Repairs to sealed components

1) During repairs to sealed components, all electrical supplies shall be disconnected from the equipment being worked upon prior to any removal of sealed covers, etc. If it is absolutely necessary to have an electrical supply to equipment during servicing, then a permanently operating form of leak detection shall be located at the most critical point to warn of a potentially hazardous situation.

2) Sealed electrical components shall be replaced.

12. Repair to intrinsically safe components

Do not apply any permanent inductive or capacitance loads to the circuit without ensuring that this will not exceed the permissible voltage and current permitted for the equipment in use.

Intrinsically safe components must be replaced.

Replace components only with parts specified by the manufacturer. Other parts may result in the ignition of refrigerant in the atmosphere from a leak.

13. Cabling

Check that cabling will not be subject to wear, corrosion, excessive pressure, vibration, sharp edges or any other adverse environmental effects. The check shall also take into account the effects of aging or continual vibration from sources such as compressors or fans.

14. Detection of flammable refrigerants

Under no circumstances shall potential sources of ignition be used in the searching for or detection of refrigerant leaks. A halide torch (or any other detector using a naked flame) shall not be used. The following leak detection methods are deemed acceptable for all refrigerant systems. Electronic leak detectors may be used to detect refrigerant leaks but, in the case of FLAMMABLE REFRIGERANTS, the sensitivity may not be adequate, or may need re-calibration. (Detection equipment shall be calibrated in a refrigerant-free area.)

Ensure that the detector is not a potential source of ignition and is suitable for the refrigerant used.

Leak detection equipment shall be set at a percentage of the LFL of the refrigerant and shall be calibrated to the refrigerant employed, and the appropriate percentage of gas (25 % maximum) is confirmed.

Leak detection fluids are also suitable for use with most refrigerants but the use of detergents containing chlorine shall be avoided as the chlorine may react with the refrigerant and corrode the copper pipe-work.

If a leak is suspected, all naked flames shall be removed/extinguished.

If a leakage of refrigerant is found which requires brazing, all of the refrigerant shall be recovered from the system, or isolated (by means of shut off valves) in a part of the system remote from the leak. Removal of refrigerant shall be according to Removal and evacuation.

15. Removal and evacuation

When breaking into the refrigerant circuit to make repairs -or for any other purpose- conventional procedures shall be used. However, for flammable refrigerants it is important that best practice be followed, since flammability is a consideration.

SERVICING SAFETY PRECAUTIONS

The following procedure shall be adhered to:

- safely remove refrigerant following local and national regulations;
- purge the circuit with inert gas(optional for A2L);
- evacuate(optional for A2L);
- continuously flush or purge with inert gas when using flame to open circuit ; and
- open the circuit.

The refrigerant charge shall be recovered into the correct recovery cylinders if venting is not allowed by local and national codes. For appliances containing flammable refrigerants, the system shall be purged with oxygen-free nitrogen to render the appliance safe for flammable refrigerants. This process might need to be repeated several times. Compressed air or oxygen shall not be used for purging refrigerant systems. For appliances containing flammable refrigerants, refrigerants purging shall be achieved by breaking the vacuum in the system with oxygen-free nitrogen and continuing to fill until the working pressure is achieved, then venting to atmosphere, and finally pulling down to a vacuum (optional for A2L). This process shall be repeated until no refrigerant is within the system (optional for A2L). When the final oxygen-free nitrogen charge is used, the system shall be vented down to atmospheric pressure to enable work to take place.

The outlet for the vacuum pump shall not be close to any potential ignition sources, and ventilation shall be available.

16. Charging procedures

In addition to conventional charging procedures, the following requirements shall be followed.

- Ensure that contamination of different refrigerants does not occur when using charging equipment. Hoses or lines shall be as short as possible to minimise the amount of refrigerant contained in them.
- Cylinders shall be kept in an appropriate position according to the instructions.
- Ensure that the REFRIGERATING SYSTEM is earthed prior to charging the system with refrigerant.
- Label the system when charging is complete (if not already).
- Extreme care shall be taken not to overfill the REFRIGERATING SYSTEM. Prior to recharging the system, it shall be pressure-tested with the appropriate purging gas. The system shall be leak-tested on completion of charging but prior to commissioning. A follow up leak test shall be carried out prior to leaving the site.

17. Decommissioning

Before carrying out this procedure, it is essential that the technician is completely familiar with the equipment and all its detail. It is recommended good practice that all refrigerants are recovered safely. Prior to the task being carried out, an oil and refrigerant sample shall be taken in case analysis is required prior to re-use of recovered refrigerant.

It is essential that electrical power is available before the task is commenced.

- a) Become familiar with the equipment and its operation.
- b) Isolate system electrically.
- c) Before attempting the procedure, ensure that:

SERVICING SAFETY PRECAUTIONS

- Mechanical handling equipment is available, if required, for handling refrigerant cylinders;
 - All personal protective equipment is available and being used correctly;
 - The recovery process is supervised at all times by a competent person;
 - Recovery equipment and cylinders conform to the appropriate standards.
- d) Pump down refrigerant system, if possible.
- e) If a vacuum is not possible, make a manifold so that refrigerant can be removed from various parts of the system.
- f) Make sure that cylinder is situated on the scales before recovery takes place.
- g) Start the recovery machine and operate in accordance with instructions.
- h) Do not overfill cylinders (no more than 80 % volume liquid charge).
- i) Do not exceed the maximum working pressure of the cylinder, even temporarily.
- j) When the cylinders have been filled correctly and the process completed, make sure that the cylinders and the equipment are removed from site promptly and all isolation valves on the equipment are closed off.
- k) Recovered refrigerant shall not be charged into another REFRIGERATING SYSTEM unless it has been cleaned and checked.

18. Labelling

Equipment shall be labelled stating that it has been de-commissioned and emptied of refrigerant. The label shall be dated and signed. For appliances containing FLAMMABLE REFRIGERANTS, ensure that there are labels on the equipment stating the equipment contains FLAMMABLE REFRIGERANT.

19. Recovery

When removing refrigerant from a system, either for servicing or decommissioning, it is recommended good practice that all refrigerants are removed safely. When transferring refrigerant into cylinders, ensure that only appropriate refrigerant recovery cylinders are employed. Ensure that the correct number of cylinders for holding the total system charge is available. All cylinders to be used are designated for the recovered refrigerant and labelled for that refrigerant (i. e. special cylinders for the recovery of refrigerant). Cylinders shall be complete with pressure-relief valve and associated shut-off valves in good working order. Empty recovery cylinders are evacuated and, if possible, cooled before recovery occurs. The recovery equipment shall be in good working order with a set of instructions concerning the equipment that is at hand and shall be suitable for the recovery of the flammable refrigerant. If in doubt, the manufacturer should be consulted. In addition, a set of calibrated weighing scales shall be available and in good working order. Hoses shall be complete with leak-free disconnect couplings and in good condition.

The recovered refrigerant shall be processed according to local legislation in the correct recovery cylinder, and the relevant waste transfer note arranged. Do not mix refrigerants in recovery units and especially not in cylinders.

If compressors or compressor oils are to be removed, ensure that they have been evacuated to an acceptable level to make certain that flammable refrigerant does not remain within the lubricant.

The compressor body shall not be heated by an open flame or other ignition sources to accelerate this process. When oil is drained from a system, it shall be carried out safely.

INSTALLATION GUIDE

1. Site Safety



Open Flames Prohibited

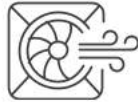
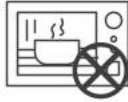

Ventilation Necessary

2. Operation Safety



Mind Static Electricity



Must wear protective clothing and anti-static gloves



Don't use mobile phone

3. Installation Safety

- Refrigerant Leak Detector
- Appropriate Installation Location

Please note that:

1. The installation site should be well-ventilated.
2. The sites for installing and maintaining an air conditioner using Refrigerant R454B should be free from open fire or welding, smoking, drying oven or any other heat source higher than 548 which easily produces open fire.
3. When installing an air conditioner, it is necessary to take appropriate anti-static measures such as wear anti-static clothing and/or gloves.
4. It is necessary to choose the site convenient for installation or maintenance wherein the air inlets and outlets of the indoor and outdoor units should be not surrounded by obstacles or close to any heat source or combustible and/or explosive environment.
5. If the indoor unit suffers refrigerant leak during the installation, it is necessary to immediately turn off the valve of the outdoor unit and all the personnel should go out till the refrigerant leaks completely for 15 minutes. If the product is damaged, it is a must to carry such damaged product back to the maintenance station and it is prohibited to weld the refrigerant pipe or conduct other operations on the user's site.
6. It is necessary to choose the place where the inlet and outlet air of the indoor unit is even.
7. It is necessary to avoid the places where there are other electrical products, power switch plugs and sockets, kitchen cabinet, bed, sofa and other valuables right under the lines on two sides of the indoor unit.

Suggested Tools

Tool	Picture	Tool	Picture	Tool	Picture
Standard Wrench		Pipe Cutter		Vacuum Pump	
Adjustable/ Crescent Wrench		Screw drivers (Phillips & Flat blade)		Safety Glasses	
Torque Wrench		Manifold and Gauges		Work Gloves	
Hex Keys or Allen Wrenches		Level		Refrigerant Scale	
Drill & Drill Bits		Flaring tool		Micron Gauge	
Hole Saw		Clamp on Amp Meter		Welding Gun	

INSTALLATION GUIDE

Operating condition

Inverter air conditioner:

HEATING	Room temperature 0°C~27°C(32°F~81°F)
	Outdoor temperature -20°C~24°C(-4°F~75°F)
COOLING/ DRY	Room temperature 17°C~32°C(63°F~90°F)
	Outdoor temperature T1 climate: -15°C~53°C(5°F~127°F)

With the power supply connected, restart the air conditioner after shutdown, or switch it to other mode during operation, and the air conditioner protection device will start. The compressor will resume operation after 3 minutes.

Features of Protector

- The protective device will trip at following cases.
 - Stop the appliance and restart it at once or change other modes during operation, you have to wait 3 minutes before restarting.
 - After switching on the power circuit breaker and then turn on the air conditioner at once, you have to wait about 20 seconds.
- In case all operations have stopped, you need.
 - Press "ON/OFF" button again to restart it.
 - Set TIMER once again if it has been canceled.

Noise pollution

- Install the air conditioner in a place that can bear its weight in order to operate more quietly.
- Install the outdoor unit in a place where the air discharged and the operation noise do not annoy your neighbors.
- Do not place any obstacles in front of the outlet of the outdoor unit for fear it affects operation and increases the noise level.

Inspection

- After a long time of operation, the air conditioner should be inspected for the following items.
- Abnormal heating of the power supply cord or even a burnt smell.
 - Abnormal operating noise or vibration.
 - Water leakage from indoor unit.
 - Metal cabinet electrified.
 - Stop using the air conditioner if above problem happened.
 - It is advisable that the air conditioner should be given a detail check-up after using for five years even if none of the above happen.

Features of HEATING mode

Preheat

2-5 minutes are necessary to preheat the indoor heat exchanger at the beginning of "HEATING" operation, lest cold air be discharged.

Defrost

In "HEATING" operation the appliance will defrost automatically. This procedure lasts 2~10 minutes, then returns to "HEATING" mode automatically. During defrosting, indoor fan stop running and return to heating mode operation automatically when defrosting has finished.

INSTALLATION GUIDE

Indoor Unit Installation

Please select the space to install indoor unit according to the dimension show above, then install correctly, and have enough space for maintenance.

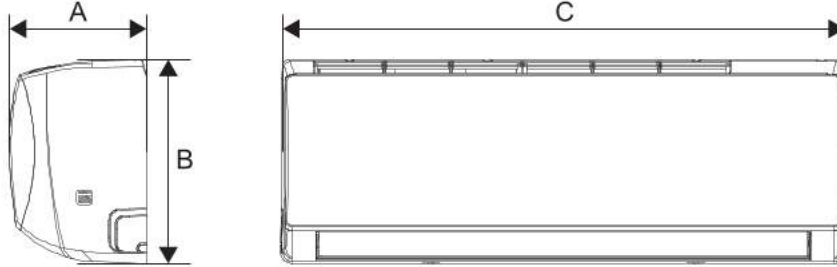

Unit: mm

Model	Indoor unit		
	A	B	C
9-12K	198	292	811
18K	206	295	909
24K	220	315	1010
36K	258	360	1191

Step1: Select Installation location

- 1) Ensure the installation complies with the installation minimum dimensions (defined below) and meets the minimum and maximum connecting piping length and maximum change in elevation as defined in the System Requirements section.
- 2) Air inlet and outlet will be clear of obstructions, ensuring proper airflow throughout the room.
- 3) Condensate can be easily and safely drained.
- 4) All connections can be easily made to outdoor unit.
- 5) Indoor unit is out of reach of children.
- 6) A mounting wall strong enough to withstand four times the full weight and vibration of the unit.
- 7) Filter can be easily accessed for cleaning.
- 8) Leave enough free space to allow access for routine maintenance.
- 9) Install at least 10 ft. (3m) away from the antenna of TV set or radio. Operation of the air conditioner may interfere with radio or TV reception in areas where reception is weak. An amplifier may be required for the affected device.
- 10) Do not install in a laundry room or by a swimming pool due to the corrosive environment.
- 11) For ETL certification area, Caution: Mount with the lowest moving parts at least 8 ft. (2.4 m) above floor or grade level.

INSTALLATION GUIDE

Minimum Indoor Clearances

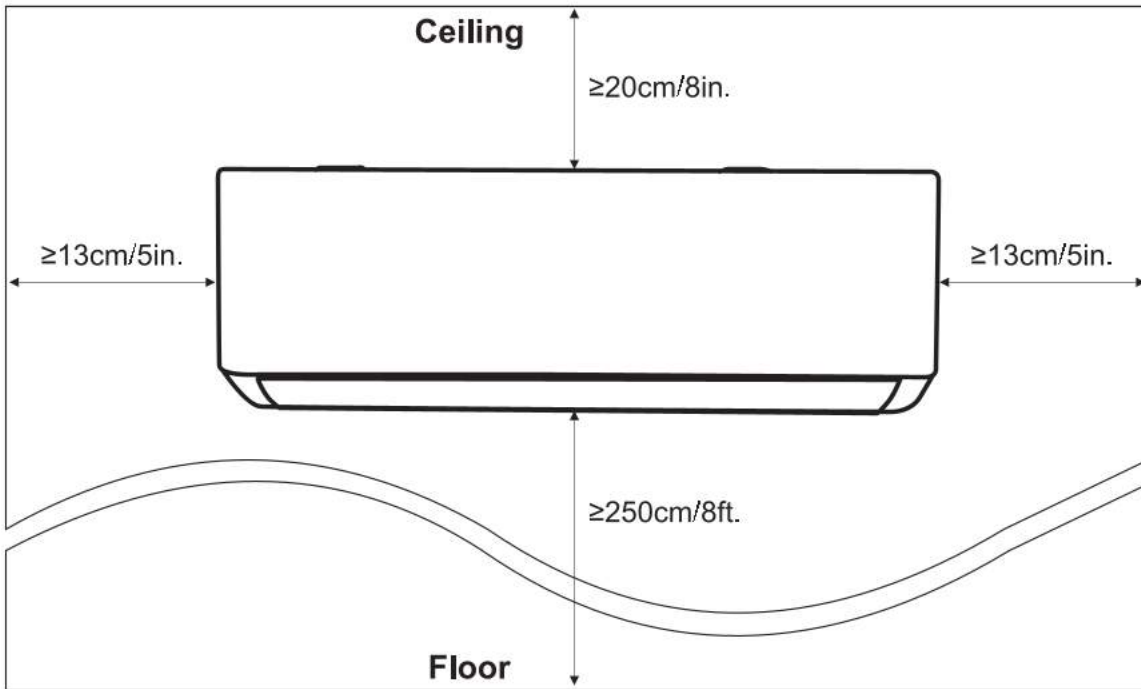

Step2: Install Mounting Plate

- 1) Take the mounting plate from the back of indoor unit.
- 2) Ensure to meet the minimum installation dimension requirements as step 1, according to the size of mounting plate, determine the position and stick the mounting plate close to the wall.
- 3) Adjust the mounting plate to a horizontal state with a spirit level, then mark out the screw hole positions on the wall.
- 4) Put down the mounting plate and drill holes in the marked positions with drill.
- 5) Insert expansion rubber plugs into the holes, then hang the mounting plate and fix it with screws.

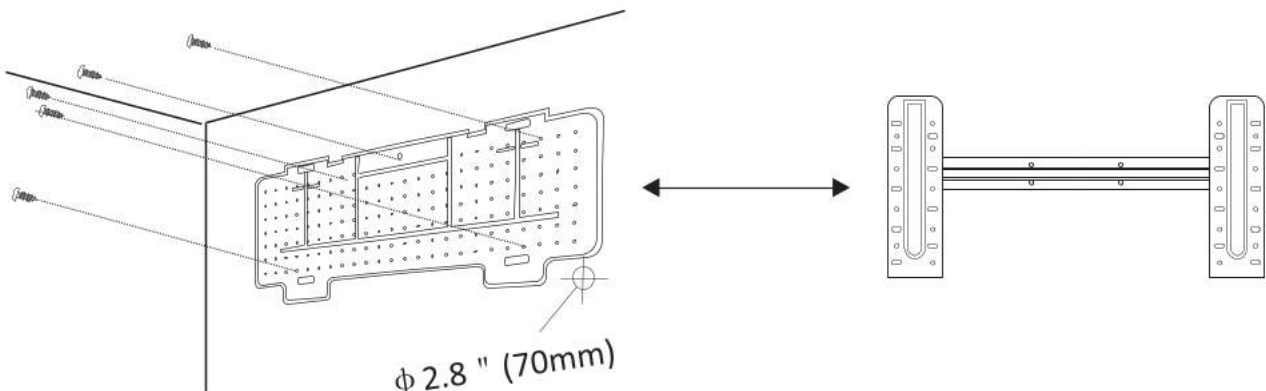

Note:

1. Make sure the mounting plate is firm enough and flat against the wall after installation.
2. This figure shown may be different from the actual object, please take the latter as the standard.

INSTALLATION GUIDE

Step3: Drill Wall Hole

A hole in the wall should be drilled for refrigerant piping ,the drainage pipe, and connecting cables.

- 1) Determine the location of wall hole base on the position of mounting plate.
- 2) The hole should be have a 70mm diameter at least and a small oblique angle to facilitate drainage.
- 3) Drill the wall hole with 70mm core drill and with small oblique angle lower than the indoor end about 5mm to 10mm.
- 4) Place the wall sleeve and wall sleeve cover(both are optional parts) to protect the connection parts.

Caution:

When drill the wall hole, maker sure to avoid wires, plumbing and other sensitive components.



Step4: Connecting Refrigerant Pipe

- 1) According to the wall hole position, select the appropriate piping mode. There are three optional piping modes for indoor units as shown in the figure below: In Piping Mode 1 or Piping Mode 3, a notch should be made by using scissors to cut the plastic sheet of piping outlet and cable outlet on the corresponding side of the indoor unit.

Note: When cutting off the plastic sheet at the outlet, the cut should be trimmed to smooth.

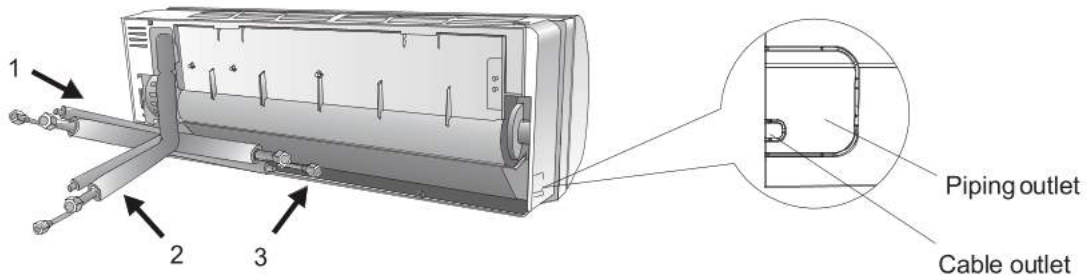

- 2) Bending the connecting pipes with the port facing up as shown in the figure.

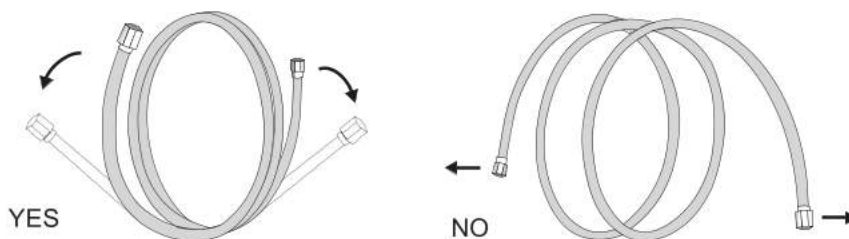

INSTALLATION GUIDE

- 3) Take off the plastic cover in the pipe ports and take off the protective cover on the end of piping connectors.
- 4) Check whether there is any sundry on the port of the connecting pipe and make ensure the port is clean.
- 5) After align the center, rotate the nut of the connecting pipe to tighten the nut as tightly as possible by hand.
- 6) Use a torque wrench to tighten it according to the torque values in the torque requirements table;(Refer to the torque requirements table on section Instruction for Servicing)
- 7) Wrap the joint with the insulation pipe.

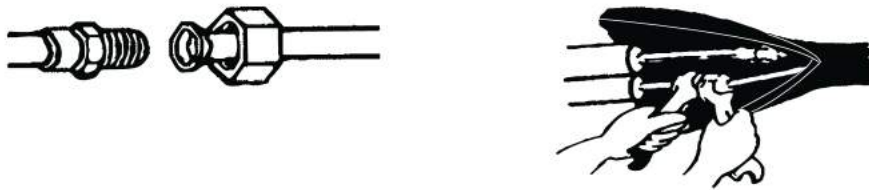

Note: For R32 refrigerant, the connectors should be placed outdoor.

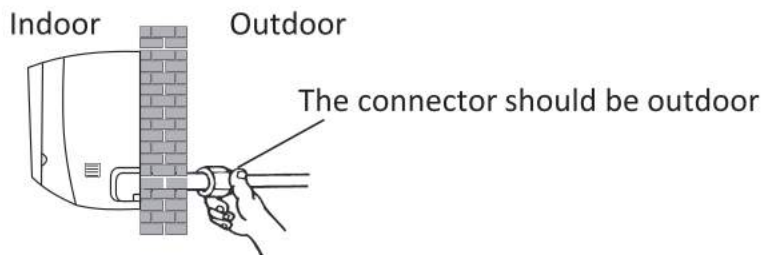

Step5: Connect Drainage Hose

- 1) Adjust the drainage hose(if applicable)

In some model, both sides of the indoor unit are provided with drainage ports, you can choose one of them to attache the drainage hose. And block the unused drain port with the rubber attached in one of the ports.

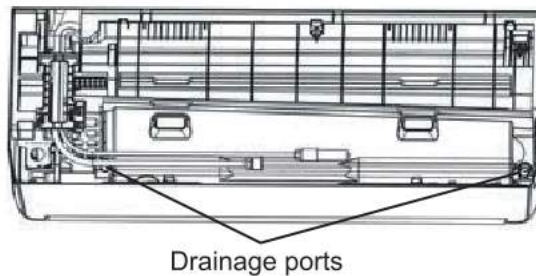

- 2) Connect the drainage hose to the drainage port, ensure the joint is firm and the sealing effect is good.
- 3) Wrap the joint firmly with teflon tape to ensure no leaks.

INSTALLATION GUIDE

Note: Make sure there is no twists or dents, and the pipes should be placed obliquely downward to avoid blockage, to ensure proper drainage.

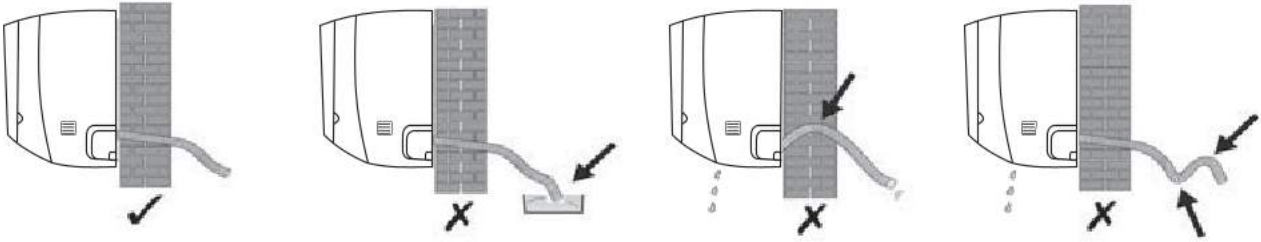

Step6: Connect Wiring

- 1) Choose the right cables size determined by the maximum operating current on the nameplate. (Check the cables size refer to section **INSTALLATION PRECAUTIONS**)
- 2) Open the front panel of indoor unit.
- 3) Use a screwdriver, open the electric control box cover, to reveal the terminal block.
- 4) Unscrew the cable clamp.
- 5) Insert one end of the cable into the position of control box from the back of the right end of the indoor unit.
- 6) Connect the wires to corresponding terminal according to the wiring diagram on the electric control box cover. And make sure that they are well connected.
- 7) Screw the cable clamp to fasten the cables.
- 8) Reinstall the electric control box cover and front panel.

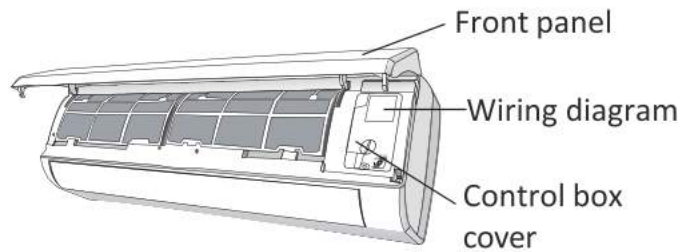

Step7: Wrap Piping and Cable

After the refrigerant pipes, connecting wires and drainage hose are all installed, in order to save space, protect and insulate them, it must be bundle with insulating tape before passing them through the wall hole.

- 1) Arrange the pipes ,cables and drainage hose well as the following picture.

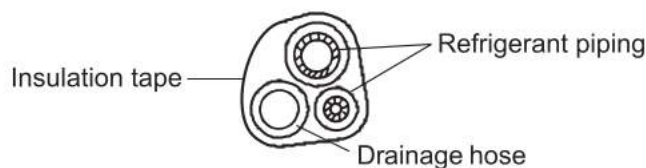

Note: (I) Make sure the drainage hose is at the bottom.

(II) Avoid crossing and bending of parts.

INSTALLATION GUIDE

- 2) Using the insulating tape wrap the refrigerant pipes, connecting wires and drainage hose together tightly.

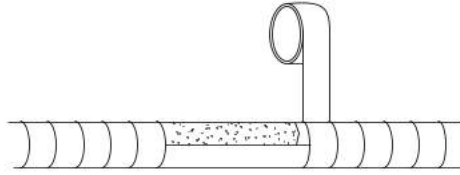

Step8: Mount Indoor Unit

1. Slowly pass the refrigerant pipes, connecting wires and drainage hose wrapped bundle through the wall hole.
2. Hook the top of indoor unit on the mounting plate.
3. Apply slight pressure to the left and right sides of the indoor unit, make sure the indoor unit is hooked firmly.
4. Push down the bottom of indoor unit to let the snaps onto the hooks of the mounting plate, and make sure it is hooked firmly.

Sometimes, if the refrigerant pipes were already embedded in the wall, or if you want to connect the pipes and wires on the wall, do as below:

- 1) Hook the top of the indoor unit on the mounting plate without piping and wiring.
- 2) Lift the indoor unit opposite the wall, unfold the bracket on the mounting plate, and use this bracket to prop up the indoor unit, there will be a big space for operation.
- 3) Do the refrigerant piping, wiring, connect drainage hose, and wrap them as **Step 4 to 7**.

INSTALLATION GUIDE

Outdoor Unit Installation

Split type outdoor unit

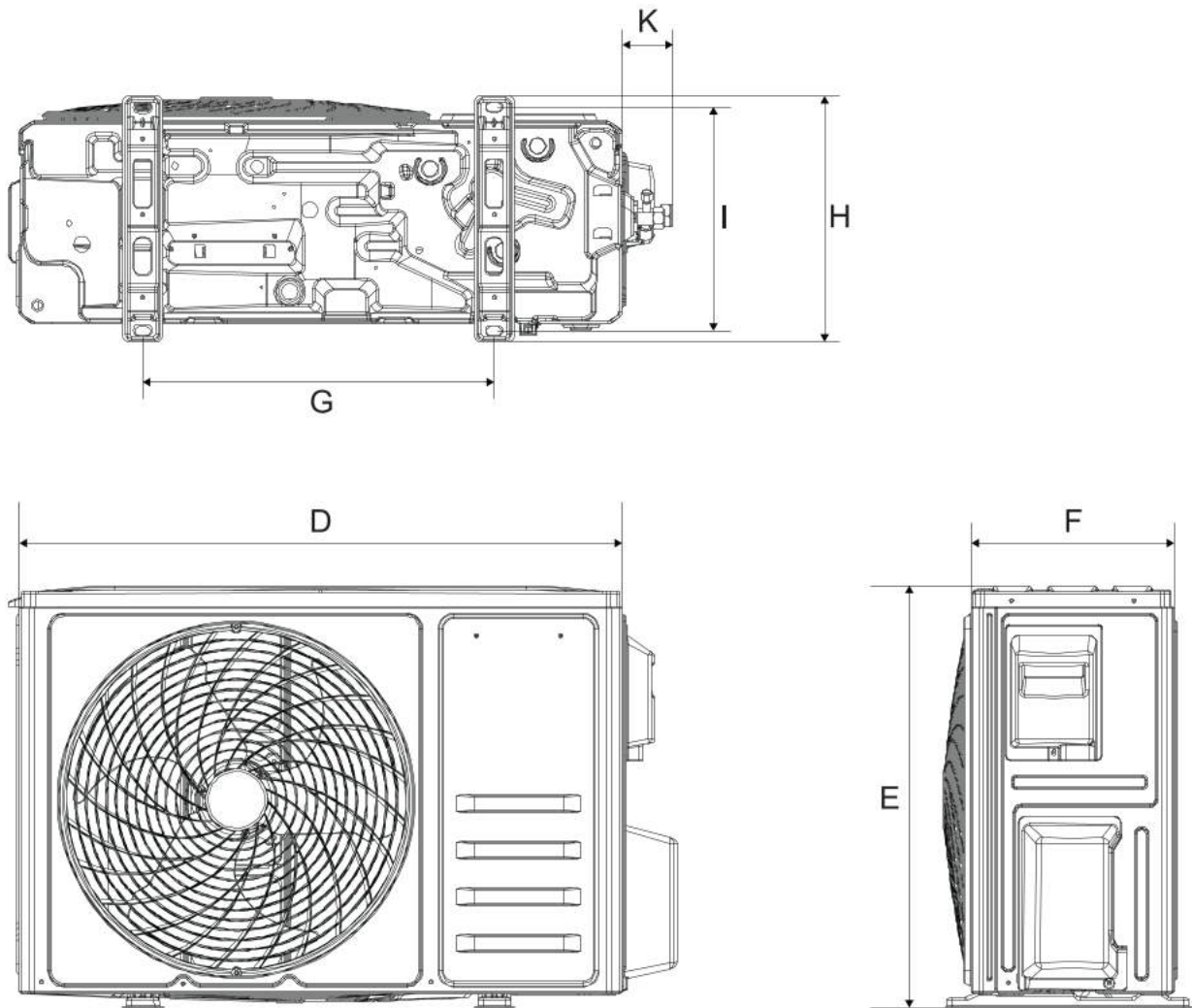

Unit: mm

Model	Outdoor unit						
	D	E	F	G	H	I	K
9K	716	498	240	415	290	263	59
12K	732	551	257	434	305	305	59
18K	780	602	292	516	349	314	58
24K	856	700	330	586	375	348	48
36K	914	804	364	607	421	390	60

INSTALLATION GUIDE

Move outdoor unit (Mainly for high-rise applications and large/heavy models)

1. Please use 4 pieces of 6mm steel wire to lift the outdoor unit and move it to the desired location.
2. To prevent the outdoor unit from being deformed, please add baffles on the surface of the outdoor unit where the steel wires may come into contact.
3. After moving, please remove the wooden tray from the bottom.

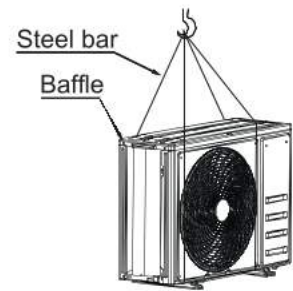

INSTALLATION SPACE

1. After leaving repair space as illustrated below, install the outdoor unit with power supply equipment installed at the side of the outdoor unit. Please refer to ELECTRIC SUPPLY INSTALLATION MANUAL for the installation method.
2. Please make sure necessary space for installation and repair.

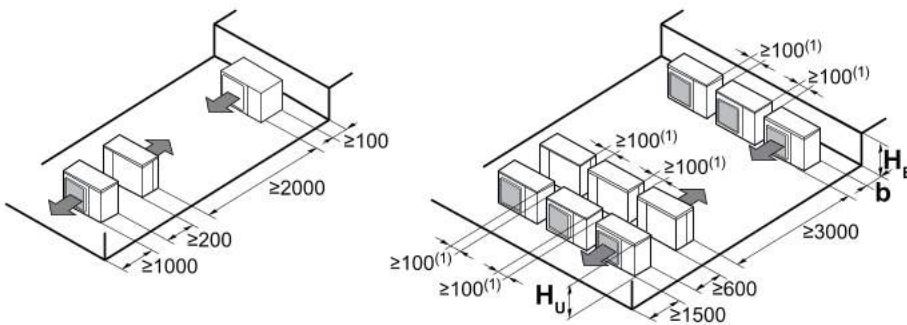
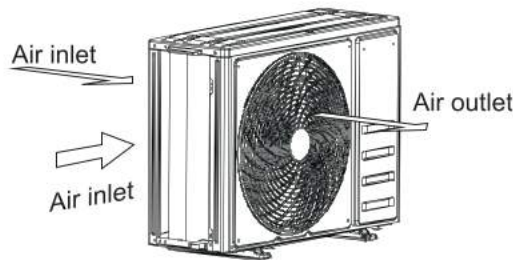

H_B H_U	b (mm)
$H_B \leq \frac{1}{2}H_U$	$b \geq 250$
$\frac{1}{2}H_U < H_B \leq H_U$	$b \geq 300$
$H_B > H_U$	/

Refrigerant pipes

1. The junction is inside the cover of the right panel. Please remove the cover first.
2. Route the pipe through the side gap of the cover.
3. After connecting via the valve opening, reinstall the cover from the left, right, or back for installation.
4. The diagram on the right is the schematic diagram of the outdoor unit's valve installation panel. The gas side (low-pressure side) is oriented upward, and the liquid side is oriented downward.

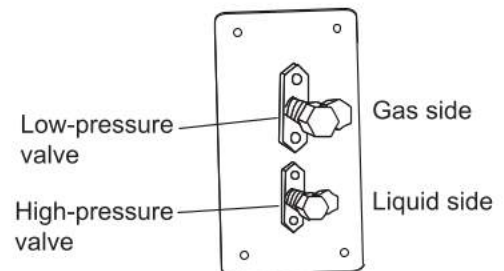

INSTALLATION GUIDE

INSTALLATION

Pre-installation precautions

- Please confirm that the installation personnel are qualified for relevant installation work. If the air conditioner is installed by persons without special skills, normal operations will not be ensured, and even personal and property safety will be affected.

User guideline

- The user's installation site should be provided with a regular power supply conforming to that indicated on the air conditioner's nameplate, and its voltage should be within the range of 90% - 110% of the rated voltage value.
- The power circuit should be equipped with a protective device, such as a leakage protector or an air switch, which should have a capacity greater than 1.5 times the maximum current value of the air conditioner.
- Please use the fuse or circuit breaker prescribed in the Installation Instructions.
- Only a qualified electrician is allowed to carry out wiring tasks strictly according to electrical safety requirements.
- Do ensure proper grounding of the air conditioner; in other words, the main power switch of the air conditioner must be connected to a reliable ground wire.

Precautions

- The air conditioner should be installed securely; otherwise poor installation may lead to abnormal noise and vibration.
- Outdoor unit should be installed at a spot ensuring that its air outlet noises and hot exhaust will not violate your neighbors.

Unit body installation

1. Mark the installation position for expansion bolts according to the outdoor unit's installation dimensions.
2. Drill holes, clean the concrete dust, and insert the expansion bolts.
3. If applicable, install 4 rubber pads on the installation holes before placing the outdoor unit (Optional).
4. Doing so will reduce vibrations and noise.
5. Place the outdoor unit onto the bolts and pre-drilled holes.
6. Use a wrench to firmly secure the outdoor unit with the bolts.

INSTALLATION GUIDE

Note:

The outdoor unit can be fixed on a wall-mounting bracket.

Follow the wall-mounting bracket's instructions to attach the bracket to the wall. Then, fasten the outdoor unit to the bracket and ensure it is level.

The wall-mounting bracket must support at least 4 times the weight of the outdoor unit.

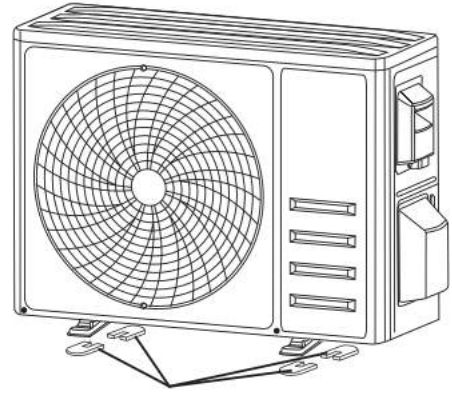

Install 4 rubber blankets (Optional)

Install Drainage Hose

1. This step only for heat pump models or RCACs.
2. Insert the drainage joint to the hole at the bottom of the outdoor unit.
3. Connect the drainage hose to the joint and make the connection well enough.

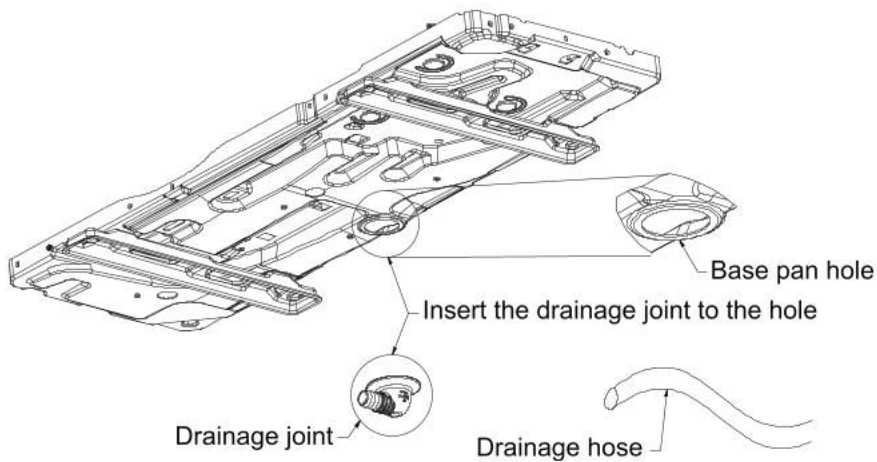

NOTE:

Before bolting the outdoor unit in place, you must install the drain joint at the bottom of the unit. For units with a base pan built-in (with multiple holes for proper draining during defrost), the drain joint is not needed to be installed.

In cold climates, ensure the drain hose is as vertical as possible to ensure swift water drainage. If water drains too slowly it can freeze in the hose and flood the unit.

INSTALLATION GUIDE

Refrigerant Pipes Installation

Pipe dimension and ways of installation

Outdoor pipe dimension and ways of install (in sequence of cooling capacity)

Pipe Material		Copper Pipe for Air Conditioner		
Model		9~18K	24K	36K
Size(mm)	Liquid side	Φ6.35 (1/4inch)	Φ6.35 (1/4inch)	Φ6.35 (1/4inch)
	Gas side	Φ9.52(3/8inch)	Φ12.7(1/2inch)	Φ15.88(5/8inch)

Conventional pipe		9/12K	18/24K	36K
Maximum pipe length (liquid side) L		15m	20m	30m
Maximum Height drop	Height drop between indoor and outdoor unit H	10m	15m	20m

Please refer to refrigerant pipe connection for detail

Allowed length and height drop

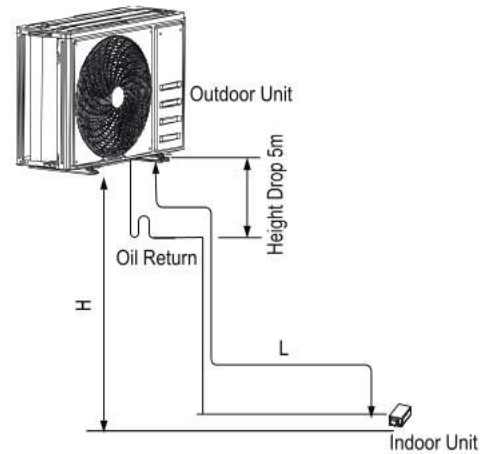

Remove objects and water

- Use high-pressure nitrogen to clean the pipe instead of using outdoor refrigerant for this cleaning process.
- Before installing the refrigerant pipe, please clean the pipe to prevent foreign objects from being inside.

Additional refrigerant charge

- The additional charge is based on the diameter and length of the outlet and inlet liquid pipes.
- This AC has been charged with a standard amount of refrigerant for 7.5m connection pipes. Connection pipes beyond 7.5m should be additionally charged as follows.

Inverter Models Capacity (Btu/h)	9K/12K	18K/24K	36K
Length of pipe with standard charge	7.5m/25ft	7.5m/25ft	7.5m/25ft
Maximum distance between indoor and outdoor unit	15m/49ft	20m/65ft	30m/98ft
Additional refrigerant charge	10g/m	10g/m	10g/m
Max. diff. in level between indoor and outdoor unit	10m/33ft	15m/49ft	20m/65ft
Type of refrigerant	R32		

INSTALLATION GUIDE

Refrigerant charge label

Please fill in with indelible ink.

- ① The factory refrigerant charge of the product
- ② The additional refrigerant amount charged in the field and refer to the step 4 on section Indoor Unit Installation.
- ① + ② the total refrigerant charge on the refrigerant charge label supplied with the product.

Affix the refrigerant charge label near the manufacturer's label after filling it out.

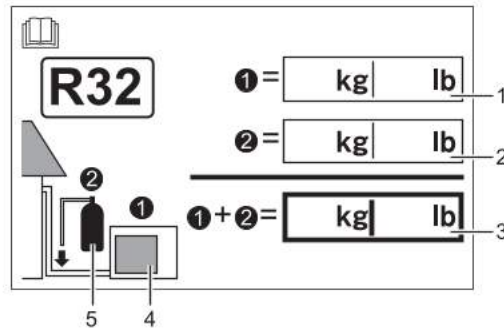

1. Factory refrigerant charge of the product: see unit manufacturer's label.
2. Additional refrigerant amount charged in the field.
3. Total refrigerant charge.
4. Outdoor unit.
5. Refrigerant cylinder and manifold for charging.

Non-return bend and oil return bend

- 1) Outdoor unit is beneath the indoor unit.

There's no need to add non-return bend at the lowest or highest position of the vertical pipe, as shown below:

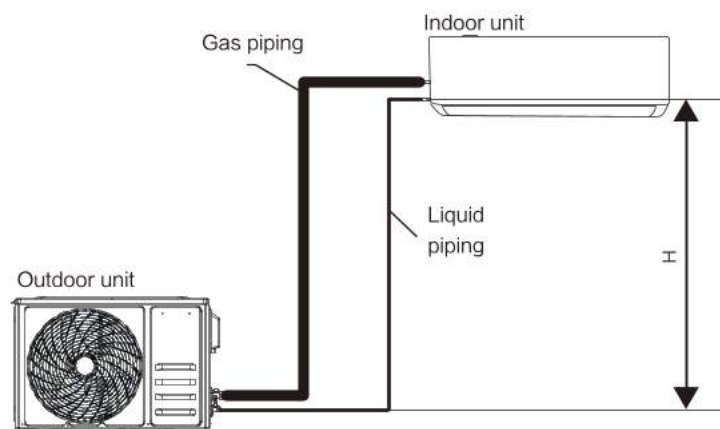

INSTALLATION GUIDE

2) Outdoor unit is above the indoor unit.

It's necessary to add oil return bend and non-return bend at the lowest and highest position of the vertical pipe, as shown below:

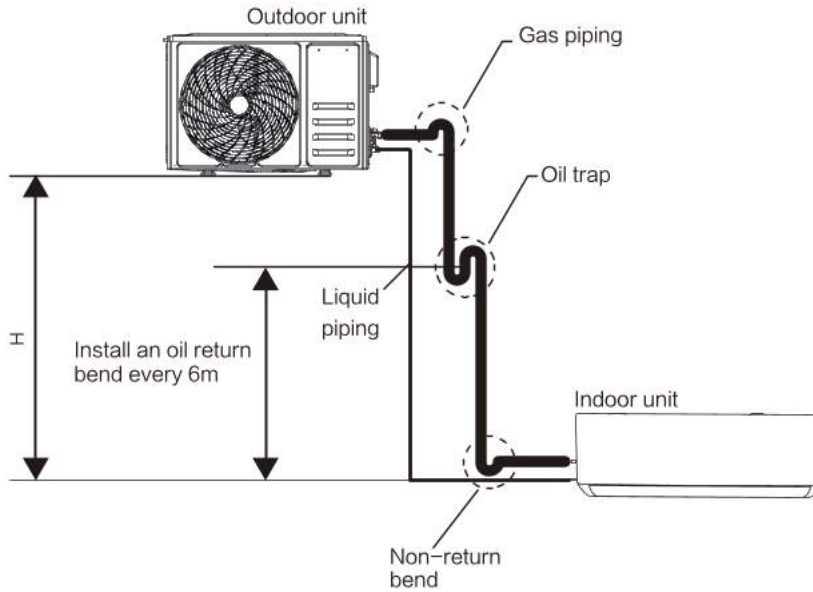

Dimensions for the making of oil return bend are as follows:

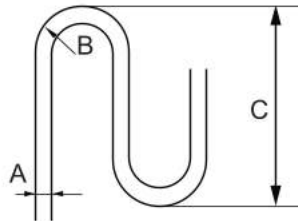

A(inch)	B(mm)	C(mm)
Φ3/8	≥20	≤150
Φ1/2	≥26	≤150
Φ5/8	≥33	≤150

FLARING

1. Cut the refrigerant pipe off with a pipe cutter.

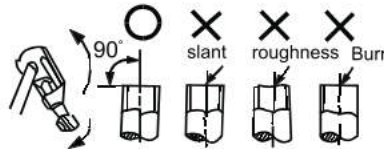

2. Flare the pipe after putting it into the connection nut.

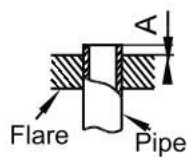

Outside Diameter	A(mm)	
	MAX	MIN
Φ1/4"	8.7	8.3
Φ3/8"	12.4	12.0
Φ1/2"	15.8	15.4
Φ5/8"	19.0	18.6
Φ3/4"	23.3	22.9

INSTALLATION GUIDE

Stop valve operation item

- Open the valve rod until it reaches the stop position. Do not attempt to open it further.
- Fasten the valve bonnet with a spanner or other similar tools.
- Ensure the valve rod bonnet is securely fastened.

Junction Fixture

Aim at the connection pipe, fix the nut of the connection pipe, and then tighten it with a spanner as shown in the following diagram.

⚠ Notice

According to the installation conditions, an excessively large tightening torque will damage the nut.

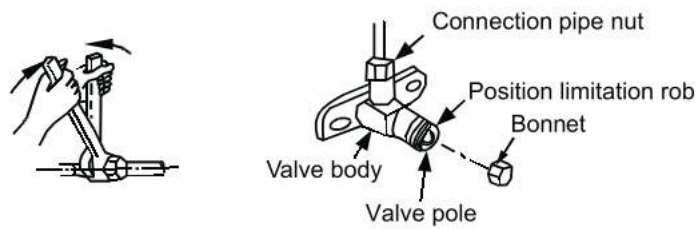

Pipe Size	Newton meter(N x m)	Pound-force foot(lbf-ft)	Kilogram-force meter(kgf-m)
1/4" (φ6.35)	15-20	11.1-14.8	1.5-2.0
3/8"(φ9.52)	31-35	22.9-25.8	3.2-3.6
1/2"(φ12)	45-50	33.2-36.9	4.6-5.1
5/8"(φ15.88)	60-65	44.3-48.0	6.1-6.6

⚠ Note: This table is only for reference, the installation shall meet the requirements of local laws and regulations.

- The following figure only shows the assembly relationship of the indoor unit ,outdoor unit and refrigerant pipes.
- Please refer to the following figures to install.

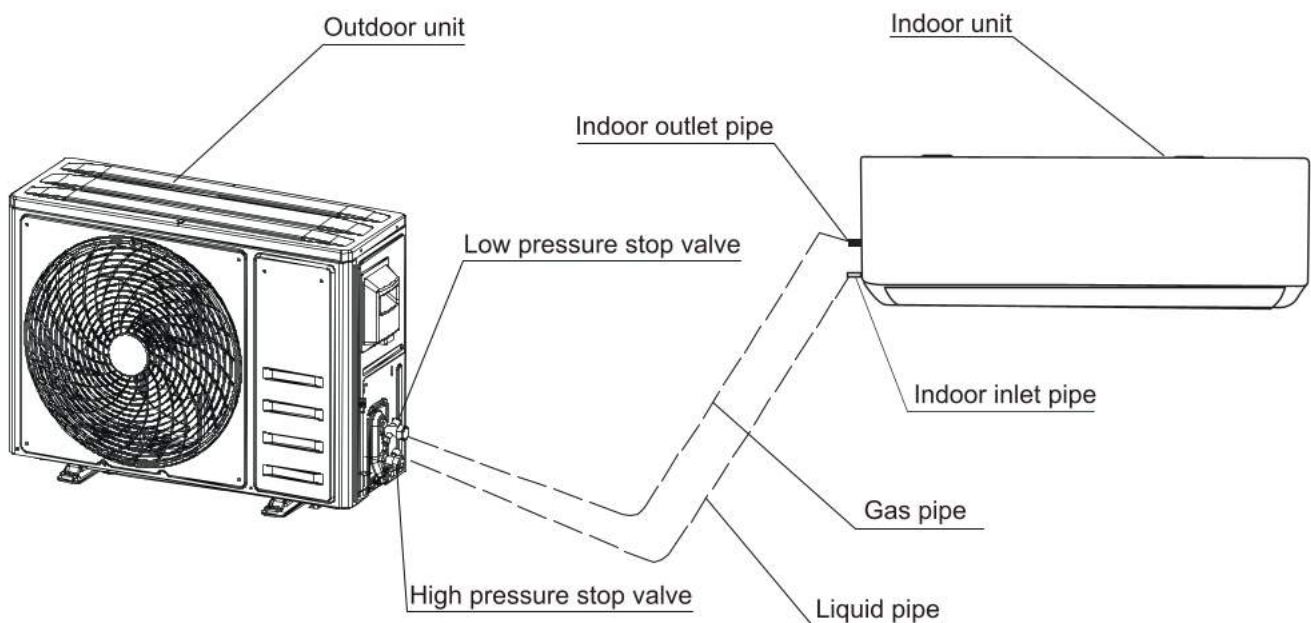

INSTALLATION GUIDE

NOTE

- The throttle subassembly has been installed in the outdoor unit.
- Use two spanners to connect the pipe with indoor/outdoor pipes to avoid the copper pipe cracking.
- Please pay attention to the connection orientation when connecting.

Joints shall be tested with detection equipment with a capability of 5g/year of refrigerant or better, with the equipment in standstill and under operation or under a pressure of at least these standstill or operation conditions.

Electric Wiring

CAUTION

- Be sure to Install Current Leakage Protection Switch.
 - Or electric shock may occur.
 - The appliance must be positioned so that the power terminal is accessible.
 - The appliance shall be installed in accordance with national wiring regulations.
1. Power cord is to be selected according to national regulations.
 2. Outdoor unit power cord should be selected and connected according to the outdoor unit installation manual.
 3. Wiring should be away from high temperature components, or the insulation layer of the wires may melt down.
 4. Use wire clamp to fix the wires and terminal block after connection.
 5. Control wire should be wrapped together with heat insulated refrigerant pipes.
 6. Connect the indoor unit to power only after the refrigerant has been vacuumed.
 7. Don't connect the power wire to the signal wire connection end.

Install Wiring

1. Use a phillips screwdriver to unscrew wiring cover, grasp and press it down gently to take it down.
2. Unscrew the cable clamp and take it down.
3. According to the wiring diagram pasted inside the wiring cover, connect the connecting wires to the corresponding terminals, and ensure all connections are firmly and securely.
4. Reinstall the cable clamp and wiring cover.

Note: When connecting the wires of indoor and outdoor units, the power should be cut off.

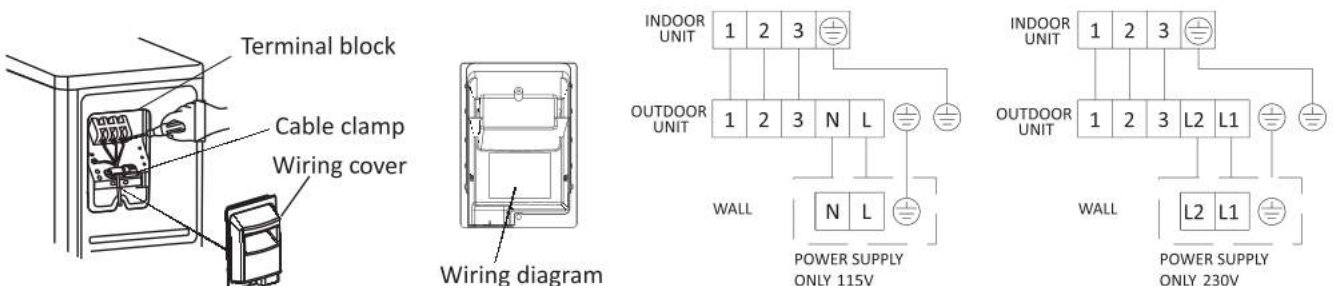

INSTALLATION GUIDE

External wiring diagrams

(9K-24K)

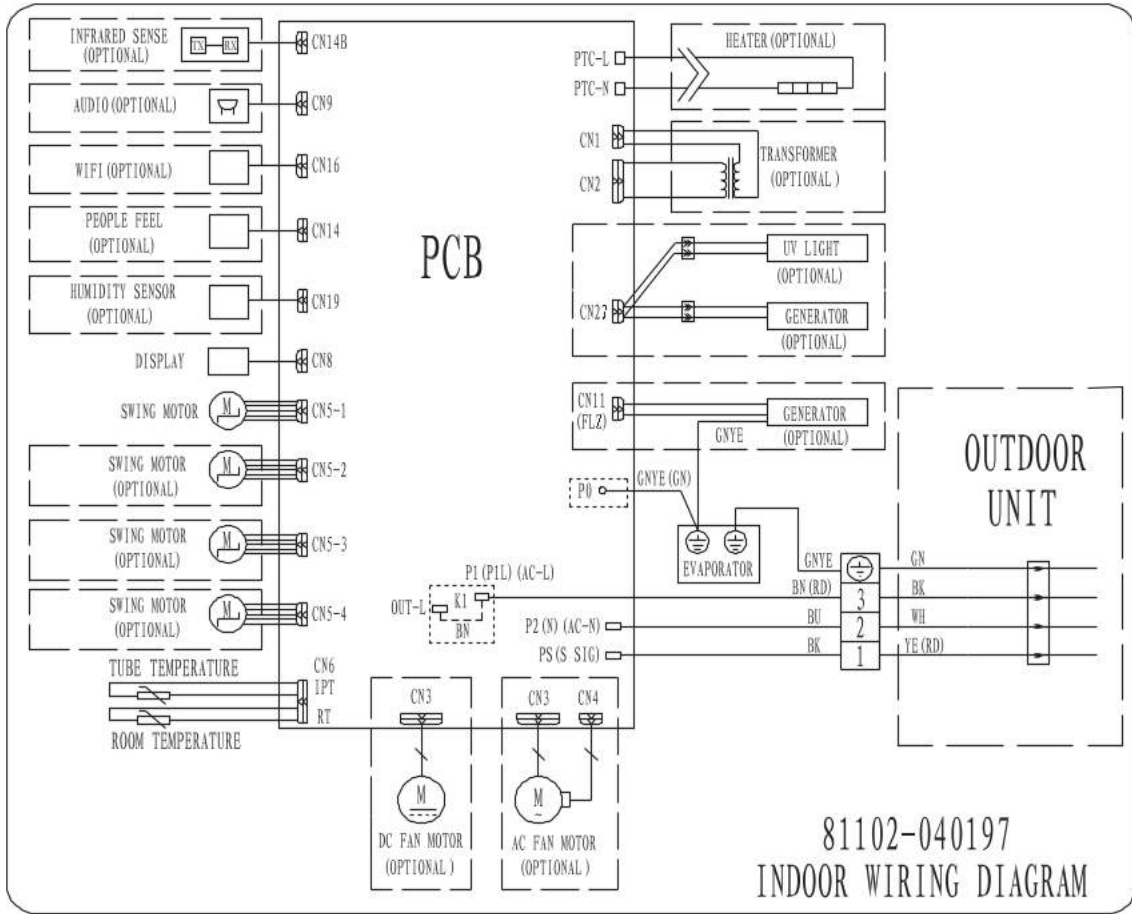

(36K)

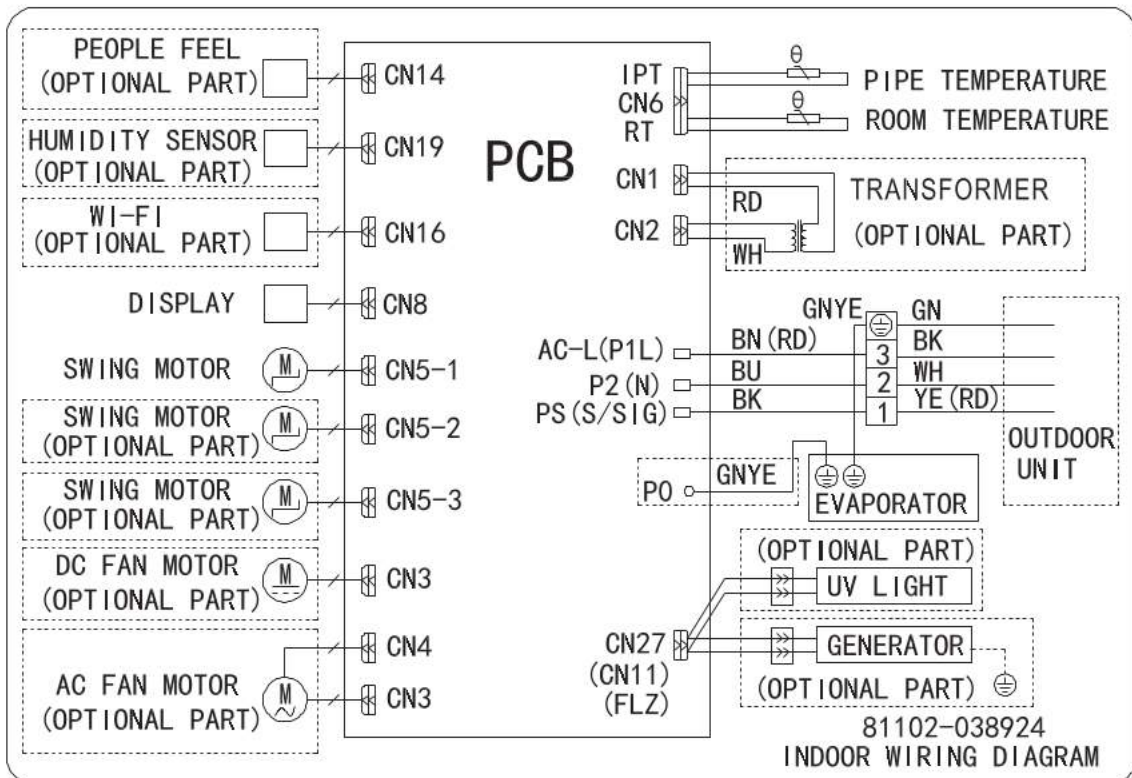

INSTALLATION GUIDE

Vacuum Pumping

- 6.1 Use a spanner to take down the protective caps from the service port, low pressure valve and high pressure valve of the outdoor unit.
- 6.2 Connect the pressure hose of manifold gauge to the service port on the outdoor unit low pressure valve.
- 6.3 Connect the charge hose from the manifold gauge to the vacuum pump.
- 6.4 Open the low pressure valve of the manifold gauge and close the high pressure valve.
- 6.5 Turn on the vacuum pump to vacuum the system.
- 6.6 The vacuum time should not be less than 15 minutes, or make sure the compound gauge indicates -0.1 MPa (-76 cmHg)
- 6.7 Close the low pressure valve of the manifold gauge and turn off the vacuum.
- 6.8 Hold the pressure for 5 minutes, make sure that the rebound of compound gauge pointer does not exceed 0.005 MPa .
- 6.9 Open the low pressure valve counterclockwise for $1/4$ turn with hexagonal wrench to let a little refrigerant fill in the system, and close the low pressure valve after 5 seconds and quickly remove the pressure hose.
- 6.10 Check all indoor and outdoor joints for leakage with soapy water or leak detector.
- 6.11 Fully open the low pressure valve and high pressure valve of the outdoor unit with hexagonal wrench.
- 6.12 Reinstall the protective caps of the service port, low pressure valve and high pressure valve of the outdoor unit.
- 6.13 Reinstall the valve cover.

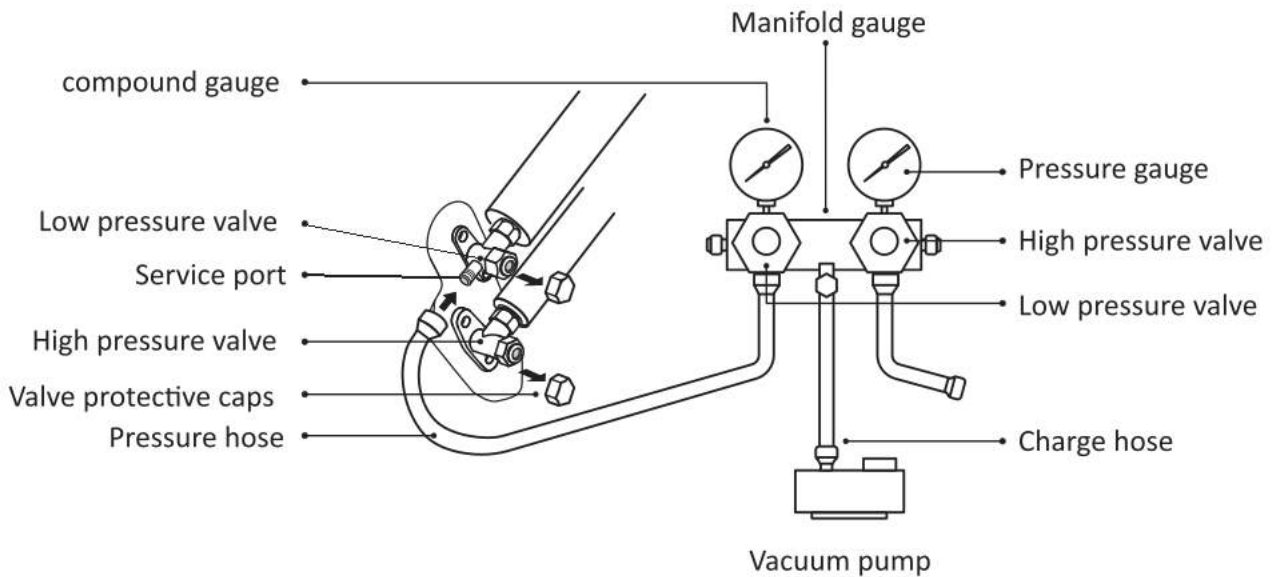

TEST OPERATION

Inspections Before Test Run

Do the following checks before test run.

Description	Inspection method
Electrical safety inspection	<ul style="list-style-type: none"> • Check whether the power supply voltage complies with specification. • Check whether there is any wrong or missing connection between the power lines, signal line and earth wires. • Check whether the earth resistance and insulation resistance comply with requirements.
Installation safety inspection	<ul style="list-style-type: none"> • Confirm the direction and smoothness of drainage pipe. • Confirm that the joint of refrigerant pipe is installed completely. • Confirm the safety of outdoor unit, mounting plate and indoor unit installation. • Confirm that the valves are fully open. • Confirm that there are no foreign objects or tools left inside the unit. • Complete installation of indoor unit air inlet grille and panel.
Refrigerant leakage detection	<ul style="list-style-type: none"> • The piping joint, the connector of the two valves of the outdoor unit, the valve spool, the welding port, etc., where leakage may occur. • Foam detection method: Apply soapy water or foam evenly on the parts where leakage may occur, and observe whether bubbles appear or not, if not, it indicates that the leakage detection result is safe. • Leak detector method: Use a professional leak detector and read the instruction of operation, detect at the position where leakage may occur. • The duration of leak detection for each position should last for 3 minutes or more; If the test result shows that there is leakage, the nut should be tightened and tested again until there is no leakage; After the leak detection is completed, wrap the exposed pipe connector of indoor unit with thermal insulation material and wrap with insulation tape.

TEST OPERATION

Test Run Instruction

1. Turn on the power supply.
2. Press the ON/OFF button on the remote controller to turn on the air conditioner.
3. Press the Mode button to switch the mode COOLING and HEATING.
In each mode set as below:
COOLING -Setthe lowesttemperature
HEATING-Setthe highesttemperature
4. Run about 8 minutes in each mode and check all functions are properly run and respond the remote controller. Functions check as recommended:
 - 4.1 Ifthe outlet air temperature responds to the cooling and heating modes
 - 4.2 Ifthe water drains properly from the drainage hose
 - 4.3 Ifthe Louver and deflectors(optional) rotate properly
5. Observe the test run state ofthe air conditioner at least 30 minutes.
6. After the successfully test run, return the normal setting and press ON/OFF button on the remote controller to turn offthe unit.
7. Inform the user to read this manual carefully before use, and demonstrate to the user how to use the air conditioner, the necessary knowledge for service and maintenance, and the reminder for storage of accessories.

Note:

Ifthe ambienttemperature exceeds the range mentioned in the section OPERATION INSTRUCTIONS, and it can not run COOLING or HEATING mode, lift the front panel and refer to the emergency button operation to run the COOLING and HEATING mode.

Dedicated Distribution Device and Wire for Air Conditioner

Wiring material ampacities	AWG
4	22
7	20
10	18
13	16
18	14
25	12
30	10
40	8
55	6
70	4

 Note: This table is only for reference, the installation shall meet the requirements of local laws and regulations. The suitable temperature for selecting wire gauge is 25°C±5°C.

Power Supply				
Model	Voltage	MCA	Breaker	Recommended power cord specifications
9K	115V	17	25	14AWG
9K	208-230V	10	15	14AWG
12K	115V	17	25	14AWG
12K	208-230V	11	15	14AWG
18K	208-230V	13	20	14AWG
24K	208-230V	20	30	14AWG
36K	208-230V	22	35	12AWG

MAINTENANCE

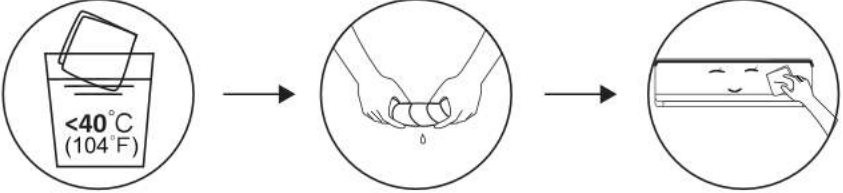
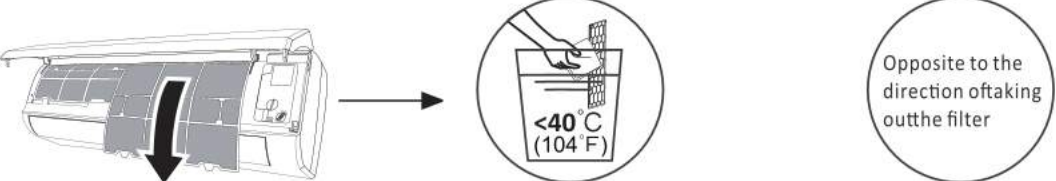
<p>Warning</p>	<ul style="list-style-type: none"> • When cleaning, you must shut down the machine and cut off the power supply for more than 5 minutes. • Under no circumstances should the air conditioner be flushed with water. • Volatile liquid (e.g. thinner or gasoline) will damage the air conditioner, so only use soft dry cloth or wet cloth dipped with neutral detergent to clean the air conditioner. • Pay attention to cleaning the filter screen regularly to avoid dust covering which will affect the filter screen effect. When the operating environment is dusty, the cleaning frequency should be increased appropriately. • After removing the filter screen, do not touch the fins of the indoor unit to avoid scratching.
<p>Clean the unit</p>	 <p>Wring it dry and gently wipe the surface of the unit</p> <p>Tip: Wipe frequently to keep air conditioner clean and good appearance .</p>
<p>Clean the filter</p>	 <p>Take out the filter from the unit</p> <p>Clean the filter with soapy water and air dry it</p> <p>Replace the filter</p> <p>Opposite to the direction of taking out the filter</p> <p>Tip: When you find accumulated dust in the filter, please clean the filter in time to ensure the clean, healthy and efficient operation inside the air conditioner.</p>
<p>Service and maintenance</p>	<ul style="list-style-type: none"> • When the air conditioner is not in use for a long time, do the following work: Take out the batteries of the remote controller and disconnect the power supply of the air conditioner. • When starting to use after long-term shutdown: <ol style="list-style-type: none"> 1. Clean the unit and filter screen; 2. Check whether there are obstacles at the air inlet and outlet of indoor and outdoor units; 3. Check whether the drain pipe is unobstructed; Install the batteries of the remote controller and check whether the power is on.

TROUBLESHOOTING

MALFUNCTION	POSSIBLE CAUSES
The appliance does not operate	Power failure/plug pulled out.
	Damaged indoor/outdoor unit fan motor.
	Faulty compressor thermomagnetic circuit breaker.
	Faulty protective device or fuses.
	Loose connections or plug pulled out.
	It sometimes stops operating to protect the appliance.
	Voltage higher or lower than the voltage range.
	Active TIMER-ON function.
	Damaged electronic control board.
Strange odor	Dirty air filter.
Noise of running water	Back flow of liquid in the refrigerant circulation.
A fine mist comes from the air outlet	This occurs when the air in the room becomes very cold, for example in the “COOLING” or “DEHUMIDIFYING/DRY” modes.
A strange noise can be heard	This noise is made by the expansion or contraction of the front panel due to variations in temperature and does not indicate a problem.
Insufficient airflow, either hot or cold	Unsuitable temperature setting.
	Obstructed air conditioner intakes and outlets.
	Dirty air filter.
	Fan speed set at minimum.
	Other sources of heat in the room.
	No refrigerant.
The appliance does not respond to commands	Remote control is not close enough to indoor unit.
	The batteries of remote control need to be replaced.
	Obstacles between remote control and signal receiver in indoor unit.
The display is off	Active DISPLAY function.
	Power failure.
Switch off the air conditioner immediately and cut off the power supply in the event of:	Strange noises during operation.
	Faulty electronic control board.
	Faulty fuses or switches.
	Spraying water or objects inside the appliance.
	Overheated cables or plugs.
	Very strong smells coming from the appliance.

TROUBLESHOOTING

ERROR CODE ON THE DISPLAY

In case of error, the display on the indoor unit shown the following error codes:

Display	Description of the trouble
E1	Indoor room temperature sensor fault
E2	Indoor pipe temperature sensor fault
E3	Outdoor pipe temperature sensor fault
E4	Refrigerant system leakage or fault
E6	Malfunction of indoor fan motor
E7	Outdoor ambient temperature sensor fault
E0	Indoor and outdoor communication fault
E8	Outdoor discharge temperature sensor fault
E9	Outdoor IPM module fault
EA	Outdoor current detect fault
EE	Outdoor PCB EEPROM fault
EF	Outdoor fan motor fault
EH	Outdoor suction temperature sensor fault

DISPOSAL GUIDELINE

This appliance contains refrigerant and other potentially hazardous materials. When disposing of this appliance, the law requires special collection and treatment. **DO NOT** dispose of this product as household waste or unsorted municipal waste.

When disposing of this appliance, you have the following options:

- Dispose of the appliance at designated municipal electronic waste collection facility.
- When buying a new appliance, the retailer will take back the old appliance free of charge.
- The manufacturer will also take back the old appliance free of charge.
- Sell the appliance to certified scrap metal dealers.
- Disposing of this appliance in the forest or other natural surroundings endangers your health and is bad for the environment. Hazardous substances may leak into the ground water and enter the food chain.



⚠ WARNING:

This product can expose you to chemicals including styrene and its compounds, which are known to the State of California to cause cancer or birth defects or other reproductive harm. For more information go to www.P65Warnings.ca.gov.

Important:

This warning is legally required by California's Proposition 65, which mandates disclosure even for trace amounts of certain substances. The warning does not indicate that the product is unsafe when used as intended; the risk primarily applies to long-term exposure to significant amounts of these substances. The levels in this product are negligible and within safe limits.

WARRANTY & CONTACT

We're Here to Support You

At Waykar, your satisfaction matters. If you have questions about your product, need assistance, or require replacement parts, our customer support team is ready to help.

Email: support@waykar.com | Phone: (213) 895-4871

Manufacturer's Warranty

All Waykar products are covered by a 12-month limited manufacturer's warranty from the date of purchase. This warranty applies to products purchased directly from Waykar or through authorized retailers. An order invoice or proof of purchase may be required when requesting service.

Extend Your Warranty by 1 Year

Register your product on our official website to enjoy an additional 12 months of warranty coverage—at no extra cost.

How to register:

Visit www.waykar.com and complete the product registration form. Please include your Order ID and Date of Purchase, if applicable.

What Is Not Covered

The warranty does not cover damage resulting from improper use or handling, including but not limited to:

1. Failing to follow the instructions in the manual.
2. Purposeful mishandling of the device.
3. Damaging the device through violent impact.
4. Exposing the device to liquids or infiltrating foreign particles.
5. Unauthorized modification or overhauling of the device.
6. Damage from placing the device upside down.

Normal wear and tear is not covered under warranty.

WAYKAR Office

📍 221 York Rd, Blacksburg, SC 29702 USA

✉ Email: support@waykar.com

☎ Tel: (213)-895-4871

💬 Live Chat: www.waykar.com

🕒 24/7 Full-Time Response

*Have your Order Number ready before contacting customer support.





Scan the QR code
Live Chat



@ Waykar

We hope our products will make your living space healthier and more comfortable.
Your satisfaction is our top priority.
Feel free to tag us when you share a snap on your social media.

WAYKAR All rights reserved.