

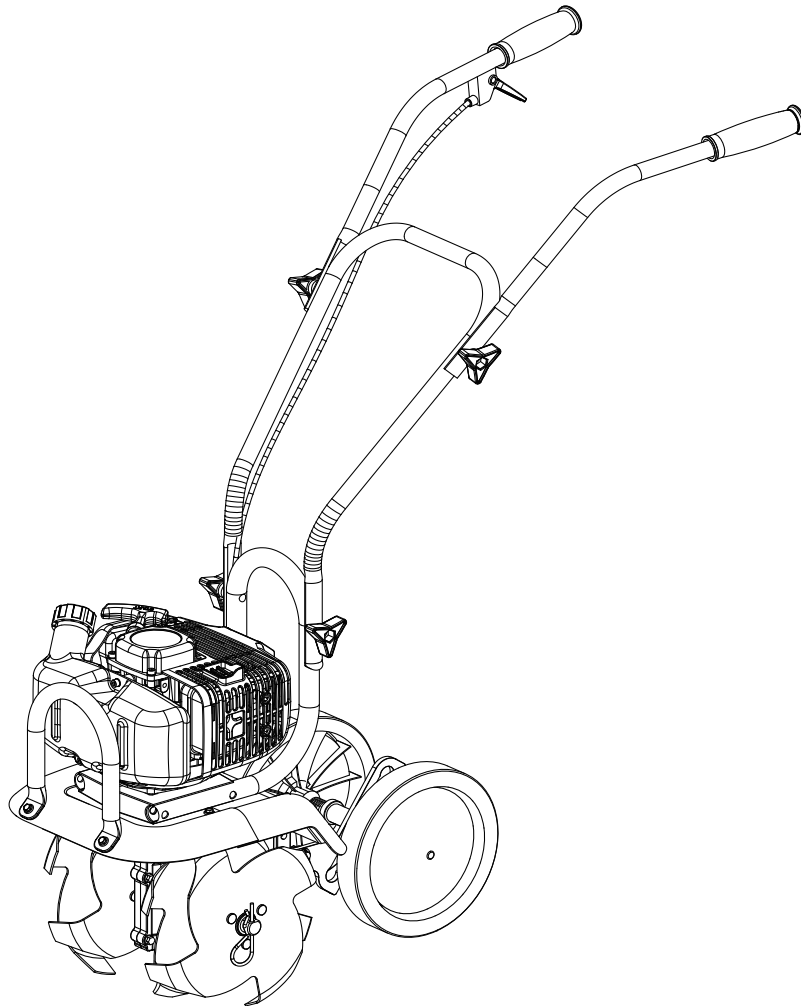

Model# PTG1110Y

Front Tine Tiller OPERATOR'S MANUAL



Warning: The Engine Exhaust from this product contains chemicals known to the State of California to cause cancer, birth defects or other reproductive harm.

| | |
|--------------|--|
| | DO NOT RETURN TO STORE! |
| | HAVE QUESTIONS OR NEED SERVICE? |
| 866-591-8921 | support@pulsar-products.com |

Table of Contents

| | | | |
|--------------------------|---|----------------------------------|----|
| Safety Information | 2 | Assembly | 7 |
| Pre-Assembly | 6 | Operation | 8 |
| Planning Assembly | 6 | Maintenance | 13 |
| Tools Required | 6 | Care, Cleaning and Storage | 16 |
| Hardware Included | 6 | Troubleshooting | 17 |
| Package Contents | 6 | Service Parts | 18 |

Safety Information

GENERAL SAFETY

Read this operator's manual carefully in its entirety before attempting to assemble this machine. Read, understand, and follow all instructions on the machine and in the manual(s) before operation. Keep this manual in a safe place for future and regular reference and for ordering replacement parts.

- Be completely familiar with the controls and the proper use of this machine before operating it.
- This machine is a precision piece of power equipment. Therefore, exercise extreme caution at all times.
- Regularly inspect the tiller. Make sure parts are not bent, damaged, or loose.
- Use this equipment for its intended purpose only.
- Operate the unit only with guards, shields, and other safety items in place and working correctly.
- Service the unit only with authorized or approved replacement parts.
- Complete all unit maintenance and adjustments according to the instructions in this manual.
- To prevent accidental starting when setting up, transporting, adjusting or making repairs, always disconnect spark plug wire.
- Be thoroughly familiar with the controls and the proper use of the tiller before starting. Know how to stop the engine quickly.



DANGER: Indicates an imminently hazardous situation which, if not avoided, will result in death or serious injury.



WARNING: Indicates a potentially hazardous situation which, if not avoided, could result in death or serious injury.



CAUTION: Indicates a potentially hazardous situation which, if not avoided, may result in minor or moderate injury.



IMPORTANT: Indicates operation or maintenance information which is important but not hazard-related.

NOTICE: Indicates a practice not related to personal injury which, if not avoided, may result in property damage.

- To help avoid tiller tines contact or a thrown object injury, stay in operator zone behind handles and keep children, bystanders, helpers and pets at least 75 feet from tiller while it is in operation. Stop machine if anyone enters area.
- Always wear safety glasses or safety goggles during operation and while performing an adjustment or repair to protect your eyes. Thrown objects which ricochet can cause serious injury to the eyes.
- Wear sturdy, rough-soled work shoes and close-fitting pants and shirts. Shirts and pants that cover the arms and legs and steel-toed shoes are recommended. Never operate this machine while barefoot, in sandals, slippery or lightweight (e.g. canvas) shoes.

Safety (continued)

GENERAL SAFETY

- Do not put hands or feet near or under rotating parts. Keep clear of discharge area at all times as the rotating tines can cause injury.
- Never operate the tiller without proper shields, guards, control lever or other safety protective devices in place and working.
- Never operate the tiller with damaged safety devices. Failure to do so, can result in personal injury.
- Familiarize yourself with all the safety and operating decals on this equipment.
- Thoroughly inspect the area where the tiller is to be used and remove all foreign objects. Your equipment can propel small objects at high speed causing personal injury or property damage.
- Check that all nuts and bolts are tight and equipment is in good condition before each use.
- Never allow children or young teenagers to operate the tiller.
- Only allow responsible individuals, who are familiar with the instructions, to operate the tiller.
- Do not operate the tiller while under the influence of alcohol or drugs.
- The control lever is a safety device. Never attempt to bypass its operation. Doing so makes the safety device inoperative and may result in personal injury through contact with the rotating tines. The control lever must operate easily in both directions and automatically return to the disengaged position when released.
- Do not put hands or feet near or under rotating parts.
- Operate only in daylight or good artificial light. Walk, never run.
- Exercise extreme caution when operating on or crossing gravel drives, walks, or roads. Stay alert for hidden hazards or traffic.
- Exercise caution to avoid slipping or falling. Always be sure of your footing; keep a firm hold on the handle and walk; never run. Never operate the tiller at high transport speeds on slippery surfaces.
- If the equipment start to vibrate abnormally, stop the engine and check immediately for the cause. Vibration is generally a warning of trouble.
- Never leave the tiller unattended when the engine is running. Stop the engine and make sure all moving parts have stopped. Remove the wire from the spark plug.
- Muffler and engine become hot and can cause a burn. Do not touch.
- Do not run the engine indoors or inside a closed area. The exhaust fumes are dangerous, containing CARBON MONOXIDE, an ODORLESS AND DEADLY GAS.
- Watch for holes, roots, bumps, or other rough ground. Tall grass can hide obstacles.
- Always look behind and down and use caution when using reverse or pulling the tiller towards you.
- Never attempt to start the tiller unless both wheels are in the locked position. This acts as a brake for the tiller.
- Always start the tiller on the level surface.
- Only use parts and accessories made for this machine by the manufacturer. Failure to do so can result in personal injury.
- When starting engine, pull cord slowly until resistance is felt, then pull rapidly. Rapid retraction of starter cord (kickback) will pull hand and arm toward engine faster than you can let go. Broken bones, fractures, bruises or sprains could result.
- Disengage clutch lever and stop engine before leaving the tiller in operating position. Wait until the tines come to a complete stop before removing debris or making any adjustments to the tiller.
- Do not attempt to till hard soil, till too deep or till at too fast a rate that can overload the tiller.
- Gasoline is extremely flammable, and gasoline vapors can explode if ignited. Handle with care.
- Use an approved container.

Safety (continued)

GENERAL SAFETY

- Always be sure of your footing. A slip and fall can cause serious personal injury. If you feel you are losing your balance, release the control lever immediately and the tine will stop rotating.
- Do not till near drop-offs, ditches or embankments, you could lose your footing or balance.

CHILDREN SAFETY

Tragic accidents can occur if the operator is not alert to the presence of children. Children are often attracted to the tiller. They do not understand the dangers. Never assume that children will remain where you last saw them.

- Keep children out of the tilling area and under watchful care of a responsible adult other than the operator.
- Be alert and turn tiller off if a child enters the area.
- Before and while moving backwards, look behind and down for small children.
- Use extreme care when approaching blind corners, doorways, shrubs, trees, or other objects that may obscure your vision of a child who may run into the tiller.
- Keep children away from hot or running engines. They can suffer burns from a hot muffler.
- Never allow children to operate this machine.

SAFETY WHILE SERVICING

Safe Handling Of Gasoline:

- To avoid personal injury or property damage use extreme care in handling gasoline. Gasoline is extremely flammable and the vapors are explosive. Serious personal injury can occur when gasoline is spilled on yourself or your clothes, which can ignite. Wash your skin and change clothes immediately.
- Use only an approved gasoline container.
- Never fill containers inside a vehicle or on a truck or trailer bed with a plastic liner. Always place containers on the ground away from your vehicle before filling.

- This tiller has a 2-Cycle engine. Make sure your fuel mixture is 50 parts gas to 1 part oil. Failure to follow this instruction will damage the engine and void the warranty.
- Remove gas-powered equipment from the truck or trailer and refuel it on the ground. If this is not possible, then refuel such equipment on a trailer with a portable container, rather than from a gasoline dispenser nozzle.
- Keep the nozzle in contact with the rim of the fuel tank or container opening at all times until fueling is complete. Do not use a nozzle lock-open device.
- Extinguish all cigarettes, cigars, pipes and other sources of ignition.
- Never fuel machine indoors because flammable vapors will accumulate in the area.
- Never remove gas cap or add fuel while engine is hot or running. Allow engine to cool at least two minutes before refueling.
- Never over fill fuel tank. Fill tank to no more than 1 inch below bottom of filler neck to provide for fuel expansion.
- Replace gasoline cap and tighten securely.
- If gasoline is spilled, wipe it off the engine and equipment. Move machine to another area. Wait 5 minutes before starting engine.
- Never store the machine or fuel container near an open flame, spark or pilot light as on a water heater, space heater, furnace, clothes dryer or other gas appliances.
- To reduce fire hazard, keep machine free of grass, leaves, or other debris build-up. Clean up oil or fuel spillage and remove any fuel soaked debris.
- Allow machine to cool at least 5 minutes before storing.
- Never run an engine indoors or in a poorly ventilated area. Engine exhaust contains carbon monoxide, an odorless and deadly gas.
- If situations occur which are not covered in this manual, use care and good judgement. Contact Customer Support for assistance or the name of the nearest service dealer.

Safety (continued)

GENERAL SAFETY

- Before cleaning, repairing, or inspecting, make certain the tines and all moving parts have stopped. Disconnect the spark plug wire and ground against the engine to prevent unintended starting.
- Check the tines and engine mounting bolts at frequent intervals for proper tightness. Also, visually inspect tines for damage. Replace with the original equipment manufacturer's (O.E.M.) parts only, listed in this manual. "Use of parts which do not meet the original equipment specifications may lead to improper performance and compromise safety!"
- Keep all nuts, bolts, and screws tight to be sure the equipment is in safe working condition.
- Never tamper with safety devices. Check their proper operation regularly.
- After striking a foreign object, stop the engine, disconnect the spark plug wire and ground against the engine. Thoroughly inspect the tiller for any damage. Repair the damage before starting and operating the tiller.
- Tiller components, guards and shields are subject to wear and damage which could expose moving parts or allow objects to be thrown. For safety protection, frequently check components and replace immediately with original equipment manufacturer's (O.E.M.) parts only, listed in this manual. "Use of parts which do not meet the original equipment specifications may lead to improper performance and compromise safety!"
- Do not change the engine's governor setting or over-speed the engine. The governor controls the maximum safe operating speed of the engine.
- Check fuel line, tank, cap, and fittings frequently for cracks or leaks. Replace if necessary.
- Do not crank engine with spark plug removed.
- Maintain or replace safety and instruction labels, as necessary.
- Observe proper disposal laws and regulations. Improper disposal of fluids and materials can harm the environment.

Do not modify engine.

- To avoid serious injury or death, do not modify engine in any way. Tampering with the governor setting can lead to a runaway engine and cause it to operate at unsafe speeds. Never tamper with factory setting of engine governor.



WARNING: This machine is equipped with an internal combustion engine and should not be used on or near any unimproved forest-covered, brush covered or grass-covered land unless the engine's exhaust system is equipped with a spark arrestor meeting applicable local or state laws (if any).

Pre-Assembly

PLANNING ASSEMBLY

Place box on a level surface. Remove all items from box. Make sure all items listed on the package contents list are included and not damaged.

TOOLS REQUIRED



HARDWARE INCLUDED

 NOTE: Hardware not shown to actual size.

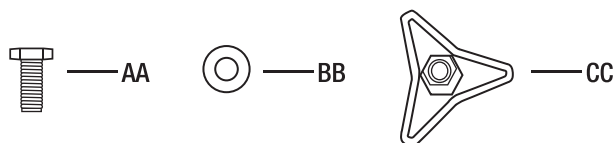

| Part | Description | Quantity |
|------|-------------|----------|
| AA | Handle Bolt | 4 |
| BB | Washer | 4 |
| CC | Wing Nut | 4 |

PACKAGE CONTENTS

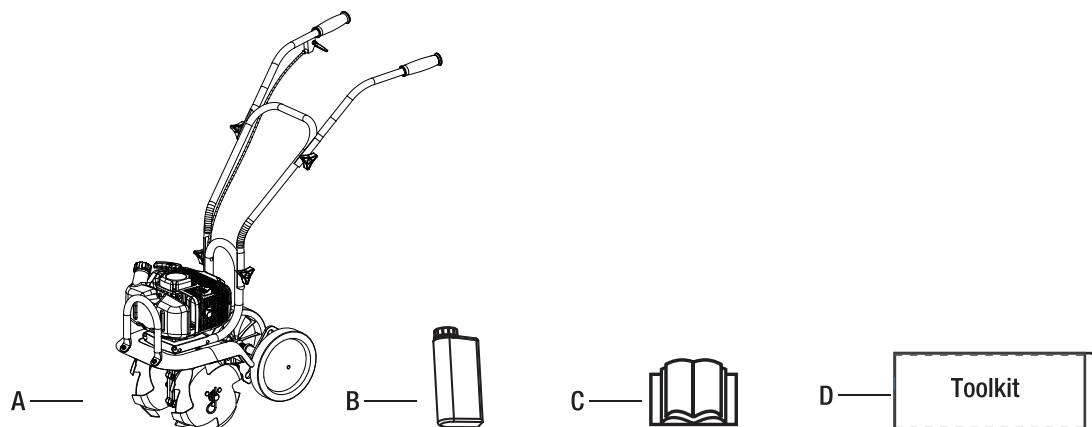

| Part | Description | Quantity |
|------|-------------|----------|
| A | Cultivator | 1 |
| B | Fuel Mixer | 1 |

| Part | Description | Quantity |
|------|-------------------|----------|
| C | Operator's Manual | 1 |
| D | Toolkit | 1 |

Assembly

1 Assembling the Handles

NOTICE: This tiller is shipped without gasoline or oil in the engine. Fill up the gasoline and oil BEFORE operating your machine.

- Place the cultivator upright with tines and wheels on a hard level surface. Wheels should be set in the lowest position.



WARNING: Do NOT place the cultivator on a high surface where it can fall and cause property damage or personal injury.

- Assemble the middle handle to the lower handle with the 2 bolts and wing nuts. Refer to Figure 1. Firmly hand-tighten the wing nuts.
- Attach the upper handles to the middle handle using the two remaining bolts and wing nuts. See Figure 1.

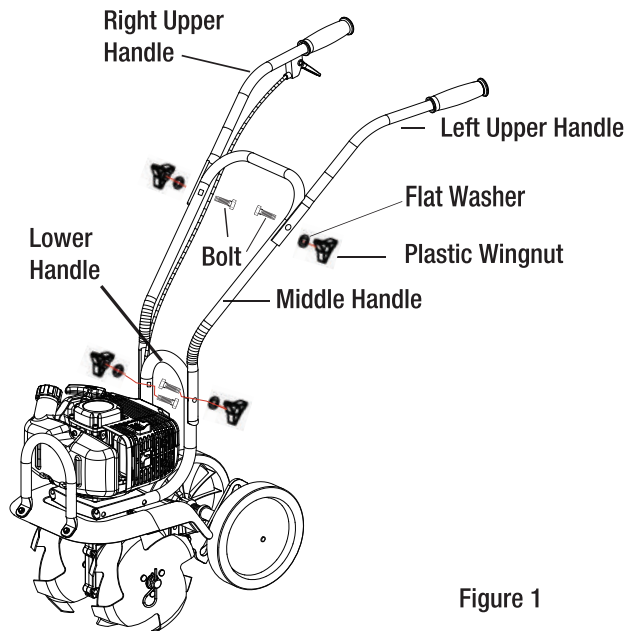

Figure 1

- Secure the throttle cable to the handle with retaining bandage already mounted to the handle.

NOTICE: Use the bandage to secure the throttle cable.

2 Assembling the Tines

- Install the tines in turn as shown below and secure them Flat Washer and Cotter Pin. See Figure 2

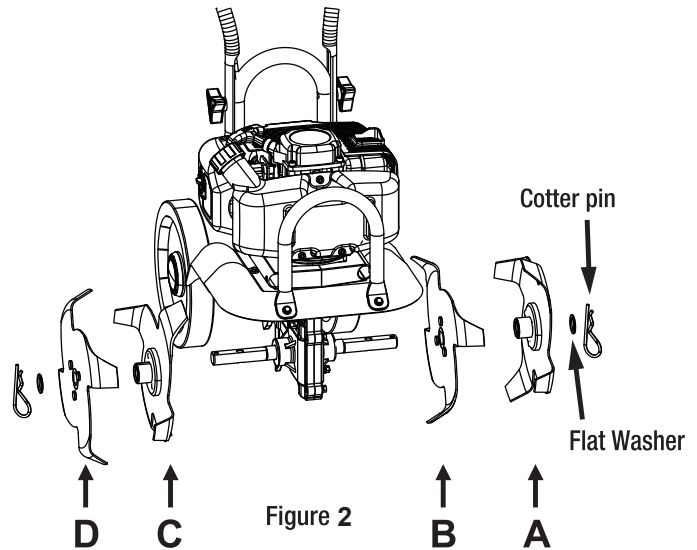

Figure 2

- Make sure to assemble the tines in order (A), (B), (C), (D). Sign is etched on the tines for reference. See Figure 3.



Figure 3

- The rotation direction of all tines should be installed in the forward direction (blade tips angle rearward), as shown in Figure 4.

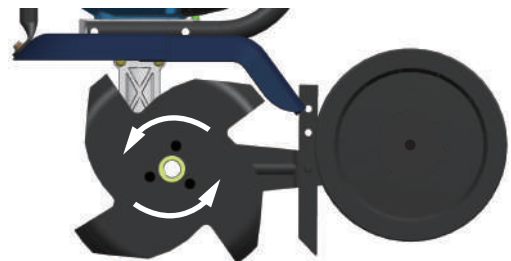

Figure 4



WARNING: Make sure the tiller protective shield is installed in place before starting the machine.

Operation

1 Adding 50 Parts Gas to 1 Part Oil



WARNING: Use extreme care when handling gasoline. Gasoline is extremely flammable and the vapors are explosive. Never fuel the machine indoors or while the engine is hot or running. Extinguish cigarettes, cigars, pipes and any other sources of ignition.

- The 2-cycle engine on your cultivator requires that fuel and 2-cycle engine oil need to be pre-mixed before adding to the fuel tank.
- Always mix the gasoline and 2-cycle oil in a container approved for gasoline. Never mix fuel directly in the engine fuel tank.
- Use fresh unleaded gasoline with an octane rating of 89 or higher and less than 10% ethanol.
- Use 2-cycle oil that meets or exceeds JASO – FC specifications and is intended for mixing at a fuel to oil ratio of 50:1. We recommend the continuous use of a 2 cycle fuel additive/stabilizer to counteract the effects of ethanol. These additives also prolong the shelf life of gasoline.



WARNING: Use of incorrect gasoline such as diesel fuel or gasoline containing more than 10% ethanol or methanol will damage the cultivator engine and void your warranty.



WARNING: Use of incorrect oil, such as automotive oil, 2-cycle marine outboard oil, or any oil other than specified oil will damage the cultivator engine and void your warranty.

- To mix the fuel and 2-cycle oil, follow instructions on 2-cycle oil container for mixing fuel. Mix gasoline and 2-cycle oil at a ratio of 50:1. A mixture with a 50:1 ratio is obtained by mixing 1 gallon (4 liters) of gasoline with 2.6 ounces of oil (77 ml). After adding oil to gasoline, shake container momentarily to ensure proper mixing.



IMPORTANT: Mix only enough fuel for your immediate needs. Do not store pre-mixed fuel.

- Stop engine and allow it to cool before refueling.
- Place the unit upright on the ground or on a sturdy bench and wipe away any debris from around the fuel cap.
- Remove fuel cap slowly and use a funnel to pour the mixture into the tank, and replace the fuel cap.
- Avoid spilling fuel or oil. Wipe up all fuel spills.
- Move at least 10 feet (3 meters) away from fueling site before starting engine.

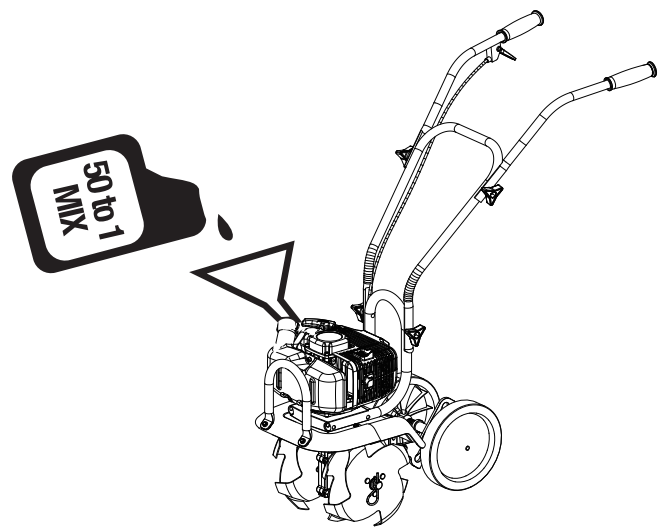

Figure 5

2 Controls and Features

RECOIL STARTER

- The recoil starter is attached to the right side of the upper handle. Stand behind the unit and pull the recoil starter rope to start the unit.

PROTECTIVE SHIELD

- The tiller shield is located in the rear of the tiller and it is used to shield you from debris being thrown.

CLUTCH LEVER

- The clutch lever located on the upper handle controls the tillers action to start the tine rotation.

ON/OFF SWITCH

- The On/Off switch is needed to start and stop the tiller.

DRAG STAKE

- In hard compacted soil, it helps restrain the tiller's forward motion. In looser soil, it controls how deeply the tines can dig into the ground.

TINES

- Tines are rotating metal blades that dig into the soil.

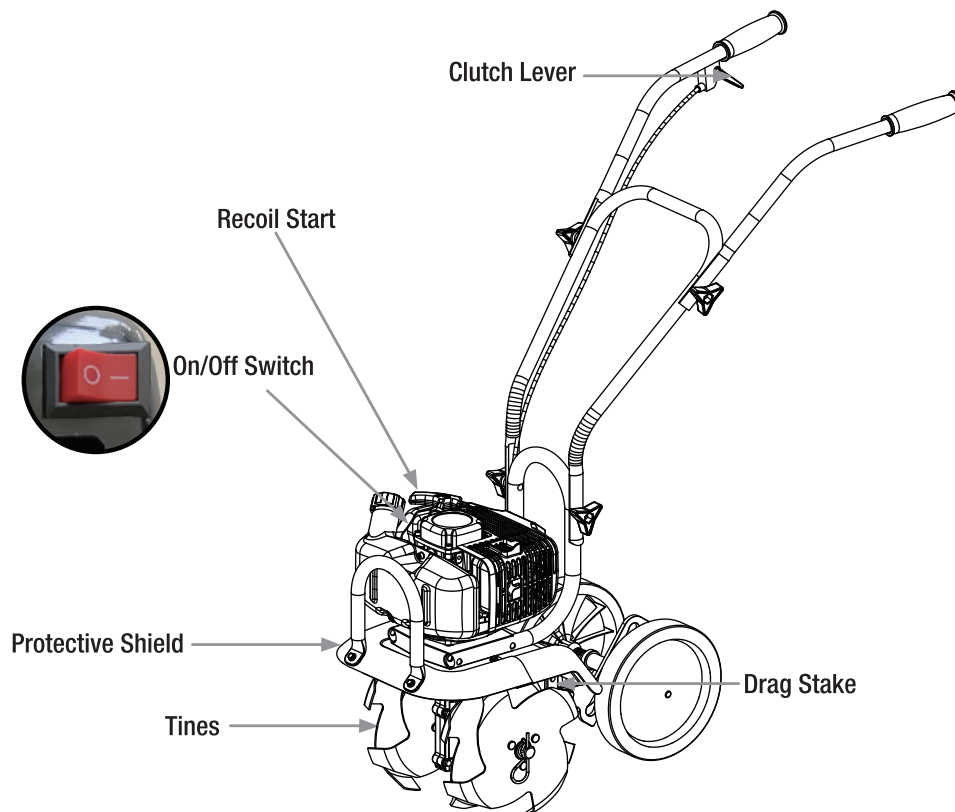

Figure 6

Operation (continued)

3 Pre-Start Inspection

- Make sure all safety guards are in place and all nuts and bolts are secure.
- Check the fuel supply. Fill the fuel tank no closer than 1 inch from top of tank to provide space for expansion.
- Be sure the spark plug wire is attached and the spark plug is tightened securely.
- Check drag stake lever position.
- Examine underneath and around engine for signs of oil or fuel leaks.
- Inspect fuel hoses for tightness and fuel seepage.
- Look for signs of engine damage.
- Remove excessive debris from muffler area and recoil starter.



CAUTION: Please do not start your tiller until you have read the manual that came with your tiller, and the sections in this manual tiller controls and safety. If you have read these, follow the steps below to start your tiller. Always perform this pre-start checklist before starting the engine.



WARNING: Gasoline is highly flammable and must be handled with care. Never fill the tank when the engine is hot or running. Always move outdoors to fill tank.

- Always set the wheels in tilling position before starting engine.
- Always put depth regulator lever in the transport position before starting engine. Tines should clear ground.



DANGER: Always keep hands and feet clear of rotating machine parts.

4 Starting the Cultivator

COLD STARTS

- Place the cultivator on a flat surface
- Move the ignition switch to the “On” position (See Figure 7)
- Move the choke lever to the ‘Cold Start’ position. (See Figure 7)
- Press the primer bulb slowly 6 times (See Figure 8)
- Grab the recoil starter handle with your right hand, and support the cultivator with your left hand.
- Pull the recoil starter handle sharply until the engine starts and runs.
- After engine starts and runs for 10-15 seconds, move choke lever to “Run/Warm Start” position (See Figure 7)



Figure 7

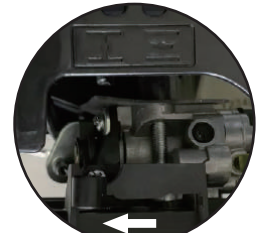

COLD START ↔ RUN/WARM START

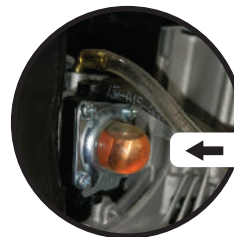

PRIMER BULB

Figure 8

Operation (continued)

RESTARTING A WARM ENGINE

- Place the cultivator on a flat surface.
- Move the ignition switch to the “On” position. (See Figure 7)
- Move the choke lever to the ‘run/warm start’ position. (See Figure 7)
- Grab the recoil starter handle with your right hand, and support the cultivator with your left hand.
- Pull the recoil starter handle sharply until the engine starts and runs.

STARTING A FLOODED ENGINE

- Place the cultivator on a flat surface.
- Move the ignition switch to the “On” position.
- Move the choke lever to the ‘Run/Warm Start’ position. (See Figure 7)
- Hold the throttle trigger fully depressed in fast position. (See Figure 9)
- Pull the recoil starter handle repeatedly until engine starts and runs. This could require pulling the recoil starter handle many times, depending on how badly the unit is flooded.
- If the engine still does not start, allow the unit to sit for about 15 minutes, and repeat steps.

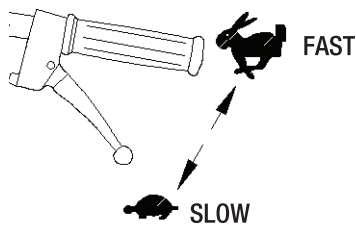

Figure 9



NOTE: When the ambient temperature is below 5°C, Refer to STARTING A FLOODED ENGINE operation.

NOTICE: If the unit still doesn't start, refer to the TROUBLESHOOTING section of this manual or: If you need assistance or have any questions, CALL TOLL FREE: 866-591-8921.

NOTICE: This cultivator is equipped with a centrifugal clutch, so the tines will not turn until the engine speed is increased. To increase the engine speed, lift up on the throttle trigger. (See Figure 9) To slow the engine down, slowly release the throttle trigger. Completely releasing the throttle lever will return the engine to idle and will stop the tines from rotating.

5 Shutting Down the Engine

- Release the throttle trigger and allow the engine to idle for a few moments.
- Move the ignition switch to the ‘OFF’ position. (See Figure 10)

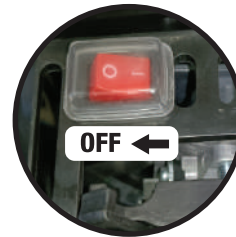

Figure 10

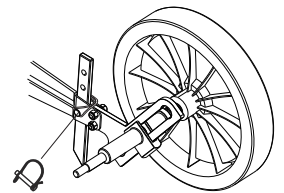

Figure 11

6 Adjusting The Drag Stake

- The drag stake adds resistance when cultivating which makes the unit easier to control. It also can be adjusted to change the depth of cultivating. To adjust the drag stake position, follow the steps below and refer to Figure 11:
- Remove the detent pin
- Slide the stake to the desired position, aligning the hole in the stake with the holes in the support bracket
- Insert the detent pin through the holes to secure the drag stake.

Operation (continued)

7 Drag Stake and Wheel Height Adjustment

NOTICE: When using Tiller, need to adjust the different heights of Drag Stake and Wheel at the same time to meet the Walking Position and Working Position.

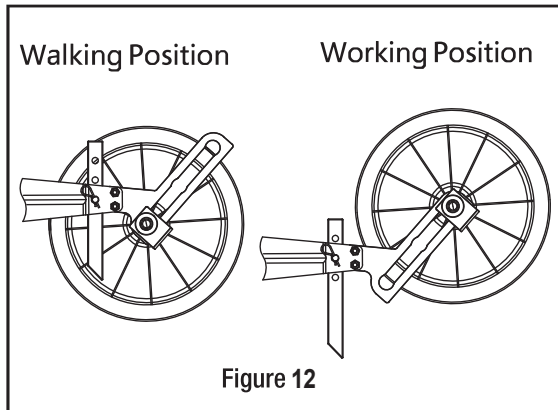

Figure 12

Walking Position

- Slide the adjustment handle to the left and move the wheels downwards. (See Figure 13)
- Remove the detent pin, adjust the drag stake upward, and drag stake with the hole and fix it with a detent pin.

Working Position

- Slide the adjustment handle to the left and move the wheels up. (See Figure 13)
- Remove the detent pin, adjust the drag stake downward, and drag stake with the hole and fix it with a detent pin.

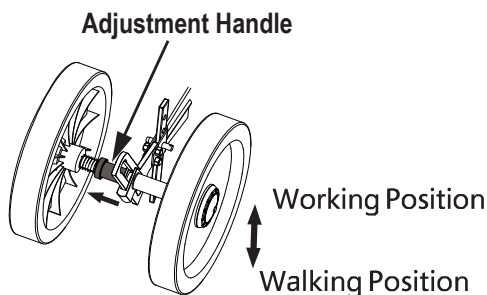

Figure 13

NOTICE: For the deepest cultivating depth, set the drag stake in its lowest position. This will give the greatest resistance and allow for the deepest depth.

8 Tilling Tips

- The key to successful tilling is to begin with a shallow cut on the first pass, and then work an inch or two deeper on each successive pass.
- Tilling depth will vary with ground conditions.
- When beginning to till in unbroken ground or in extremely hard soil, set the detent pin in the highest hole of the depth regulator. This will allow for shallow tilling. With the depth regulator in this position, make several light passes over the area to be tilled. Reset for deeper depths with successive passes.
- If tiller jumps or skids uncontrollably, lower the depth regulator by placing the detent pin in a higher hole. This will allow for shallower tilling. Hold firmly to the handlebars to control sudden lurches.
- If weeds, tall grasses, vines, or other materials clog or jam the tines, reverse the tiller to unwind vegetation.
- Immediately release the throttle trigger if the tines jam or you strike a foreign object. With the drive control levers in the neutral position, move the ignition switch to the 'OFF' position to stop the engine. Disengage the spark plug wire. When tines have stopped, remove foreign objects and check for damage.

CULTIVATING

- Set the drag stake lever with the detent pin in one of the higher holes. This will allow for shallow cultivation necessary to turn over weeds, and break up and aerate the soil.

HIGH ALTITUDE OPERATION

- If operating equipment with engines regularly at altitudes over 5,000 feet, the carburetor's air-fuel mixture will be too rich and emissions may increase. On engines not built for the United States the carburetor can be adjusted to operate under this condition. The carburetor should be returned to its normal setting if regular operation is less than 5,000 feet. Contact your service center to modify the carburetor.

Maintenance

Always observe safety rules when performing any maintenance.

- The warranty on this tiller does not cover items that have been subjected to operator abuse or negligence. To receive full value from warranty, operator must maintain the string trimmer as instructed here.
- Changing of engine-governed speed will void engine warranty.
- All adjustments should be checked at least once each season.
- Periodically check all fasteners and make sure these are tight.
- Good maintenance is your responsibility, poor maintenance is an invitation to trouble.
- Follow good shop practices.
- Keep service area clean and dry.
- Use adequate light for the job at hand.
- Make sure the engine is off before you begin any maintenance or repairs. This will eliminate several potential hazards.
- Be sure there is adequate ventilation whenever you operate the engine to avoid carbon monoxide poisoning.
- Never operate the engine in a closed building.
- Let the engine and exhaust system cool before touching.
- Do not run the engine unless instructed to do so.
- Read the instructions before you begin, and make sure you have the tools and skills required.
- To reduce the possibility of fire or explosion, be careful when working around gasoline.
- Use only a nonflammable solvent, not gasoline, to clean parts. Keep cigarettes, sparks and flames away from all fuel related parts.
- Lubricate the wheels at least once a season with light oil (or motor oil). If wheels are removed for any reason, lubricate surface of the axle bolt and inner surface of the wheel with light oil.
- Always use personal protection devices such as eye, hand and hearing protectors when performing any service or maintenance.
- Frequently check tiller tines. They should be free of nicks and cracks and securely fastened in place.
- Periodically tighten all bolts, nuts, screws, and check that all pins are properly installed to make certain the tiller is safe to operate.
- When completing maintenance or service, make sure all safety guards and devices are installed before using the tiller.
- Where replacement parts are necessary for periodic maintenance and servicing, use only new, original replacement parts or their equivalents for repair and replacement to restore your equipment to original specifications.
- The manufacturer and/or distributor will not be responsible for injuries or damages caused by use of unapproved parts and/or accessories.
- A first aid kit should be kept readily accessible while performing maintenance on this equipment.

Maintenance (continued)

MAINTENANCE SCHEDULE

- Your tiller has been designed and produced by the industry's leading manufacturer of outdoor power equipment to provide you with years of reliable operation. Keeping your tiller in top running condition will prolong its life, and help you obtain optimum performance.
- Please read this normal care schedule, and note the recommended care operating intervals to extend the life of your tiller.

| Maintenance Operation | | Before Each Use | First Month or 20 Hours | Every 3 Months or 50 Hours | Every 6 Months or 100 Hours | Every Year or 300 Hours |
|-----------------------|--------------|--------------------------------------|-------------------------|----------------------------|-----------------------------|-------------------------|
| Air Filter | Check | √ | | | | |
| | Clean | | | √* | √* | |
| | Replace | | | | | √ |
| Tine Shaft | Clean | √ | | | | |
| Wheel Axle Shaft | Lubricate | | | √ | | |
| Spark Plug | Clean Adjust | | | | √ | |
| Fuel Strainer | Clean | | | | √ | |
| Fuel Line | Check | Every 2 Years (Replace if necessary) | | | | |

*Service more frequently when used in dusty areas.



WARNING: Use only genuine replacement parts. Other parts may damage the tiller or result in injury.

Maintenance (continued)

AIR FILTER



WARNING: Turn off ignition switch, and disconnect the spark plug before performing maintenance except for carburetor adjustments. Reconnect the spark plug wire after the service is done.

- Your cultivator has been equipped a air filter inside the air filter housing to prevent dirt and debris from entering the engine.
- Accumulated debris and dust in the air filters will reduce engine performance, increase fuel consumption, and increase the risk of damage to the engine. Inspect the air filters frequently for dust and debris build-up, and clean the air filters every 5 hours of operation (more frequently in dusty/ dirty conditions).
- Both air filters should be cleaned by following these instructions:
- Before removing air filter cover, brush away any loose dirt or debris on and around the filter cover.
- Remove the knob securing the air filter cover. (See Figure 14)
- Remove and clean foam filter. (See Figure 15)
- Light surface dust can readily be removed by tapping the filter.
- Heavy deposits should be washed out in soap and water. Squeeze out any remaining water and allow the filter to completely dry.



Figure 14

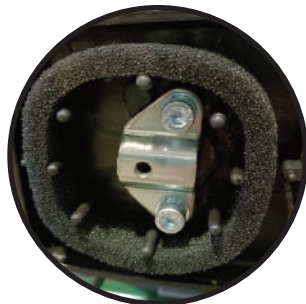

Figure 15



WARNING: Never clean filter in gasoline or other flammable solvents.

- Add a drop of thin oil to the filters and replace it.
- Remove the paper air filter element. Clean filter by gently tapping it on a flat surface. Replace if very dirty.
- Reassemble the filter element and the air filter cover.

LUBRICATION

- Proper lubrication of moving mechanical parts is critical for proper care and maintenance. Oil to moving parts shown at 10 hour intervals using 30g oil.

CLEAN TINE AXLE SHAFT

- Turn off engine. Engine must be cool.
- Remove spark plug wire and secure from spark plug.
- Tip the tiller forward. Block the tiller in position so that it rests on the engine mount and the tines are exposed.
- Remove all vegetation, string, wire, and other material that may have accumulated on the axle between the inside set of tines and the seal on the transmission housing.
- Tip the tiller back to a level position.
- Replace spark plug wire.

SPARK PLUG

- To prevent fuel gum deposits and corrosion in the unit's carburetor and fuel system, it is highly recommended to use a fuel additive/stabilizer formulated for ethanol fuels. Follow the stabilizer manufacturer's instructions. Run the engine at least 5 minutes after adding stabilizer.

SPARK PLUG CONTINUED

To inspect or replace the spark plug:

- Remove the insulated spark plug boot.
- Use the spark plug wrench to remove the spark plug, by turning counter-clockwise.
- Visually inspect the spark plug for cracks or damage. If damaged, replace spark plug with a recommended replacement (see “Product Specifications”).
- Clean carbon deposits. If excessive carbon build up, replace spark plug.
- Adjust the spark plug gap to 0.024 – 0.028 in. (0.6 - 0.7mm).
- Install the spark plug finger tight in the cylinder head, and then tighten firmly with the spark plug wrench.
- Re-install the insulated spark plug boot.

Follow the steps below to prepare your tiller for storage.

- Protect wheels and axles from rust by removing the lockpin and sliding the wheel off the hub.
- Coat the axles lightly with axle grease.
- Drain fuel system completely or add fuel stabilizer to prevent fuel from gumming up during extended storage period.
- Clean external surfaces, engine and cooling fan.
- Remove spark plug, pour one ounce of SAE 30 oil into spark plug hole.
- Plug hole and pull starter cord slowly to distribute oil evenly in cylinder head area.
- Reinstall spark plug.
- Transport unit to a suitable storage location. If you have chosen to use a fuel stabilizer and have not drained the fuel system, follow all safety instructions storage precautions in this manual to prevent the possibility of fire from the ignition of gasoline fumes. Remember, gasoline fumes can travel to distant sources of ignition and ignite, causing risk of explosion and fire.
- If there is any possibility of unauthorized use or tampering, remove the spark plug and store it in a safe place before storing the rototiller unit.
- Be sure to plug the spark plug hole to prevent foreign material from entering.



WARNING: Do not store tiller in an unventilated area where fuel fumes may reach flame, sparks, pilot lights or an ignited object. Drain fuel outdoors away from any ignition sources. Use only approved fuel containers.

Troubleshooting

| Problem | Cause | Solution |
|--|--|--|
| Engine will not start. | <ul style="list-style-type: none"> <input type="checkbox"/> Ignition Switch in the "OFF" position. <input type="checkbox"/> Engine flooded. <input type="checkbox"/> Fuel Tank empty. <input type="checkbox"/> Spark Plug not firing. <input type="checkbox"/> Fuel not reaching carburetor. <input type="checkbox"/> Carburetor requires adjustment. | <ul style="list-style-type: none"> <input type="checkbox"/> Move ignition switch to the ON position. <input type="checkbox"/> See Starting a Flooded Engine in OPERATION section. <input type="checkbox"/> Fill tank with correct fuel mixture. <input type="checkbox"/> Replace Spark Plug. <input type="checkbox"/> Check for kinked or split fuel line; repair or replace. <input type="checkbox"/> Contact a qualified service center. |
| Engine will not accelerate, lacks power or stalls. | <ul style="list-style-type: none"> <input type="checkbox"/> Fuel not reaching carburetor. <input type="checkbox"/> Air filter dirty. <input type="checkbox"/> Spark plug fouled. <input type="checkbox"/> Carburetor requires adjustment. <input type="checkbox"/> Carbon build-up on muffler outlet screen. <input type="checkbox"/> Compression low. | <ul style="list-style-type: none"> <input type="checkbox"/> Check for kinked or split fuel line; repair or replace. <input type="checkbox"/> Clean air filter. <input type="checkbox"/> Clean or replace spark plug <input type="checkbox"/> Contact a qualified service center. <input type="checkbox"/> Contact a qualified service center. <input type="checkbox"/> Contact a qualified service center. |
| Engine smokes excessively. | <ul style="list-style-type: none"> <input type="checkbox"/> Fuel mixture incorrect. <input type="checkbox"/> Air filter dirty. <input type="checkbox"/> Carburetor requires adjustment. <input type="checkbox"/> Choke lever in the CHOKE/COLD START position. | <ul style="list-style-type: none"> <input type="checkbox"/> Empty Fuel Tank and refill with correct fuel mixture. <input type="checkbox"/> Clean or replace air filter. <input type="checkbox"/> Contact a qualified service center. <input type="checkbox"/> Rotate choke lever to the RUN/WARM START position. |
| Engine runs hot. | <ul style="list-style-type: none"> <input type="checkbox"/> Fuel mixture incorrect. <input type="checkbox"/> Spark Plug incorrect. <input type="checkbox"/> Carburetor requires adjustment. <input type="checkbox"/> Carbon build-up on muffler outlet screen. | <ul style="list-style-type: none"> <input type="checkbox"/> See Mixing Fuel / 2-Cycle Oil in OPERATION section. <input type="checkbox"/> Replace with correct Spark Plug. <input type="checkbox"/> Contact a qualified service center. <input type="checkbox"/> Contact a qualified service center. |
| Engine will not idle properly. | <ul style="list-style-type: none"> <input type="checkbox"/> Carburetor requires adjustment. <input type="checkbox"/> Crankshaft seals worn. <input type="checkbox"/> Compression low. | <ul style="list-style-type: none"> <input type="checkbox"/> Contact a qualified service center. <input type="checkbox"/> Contact a qualified service center. <input type="checkbox"/> Contact a qualified service center. |

Service Parts

| Part | Description | Quantity |
|------|------------------|----------|
| AA | Tine | 4 |
| BB | Wheel | 2 |
| CC | Air cleaner Assy | 1 |

| Part | Description | Quantity |
|------|-------------|----------|
| DD | Recoil | 1 |

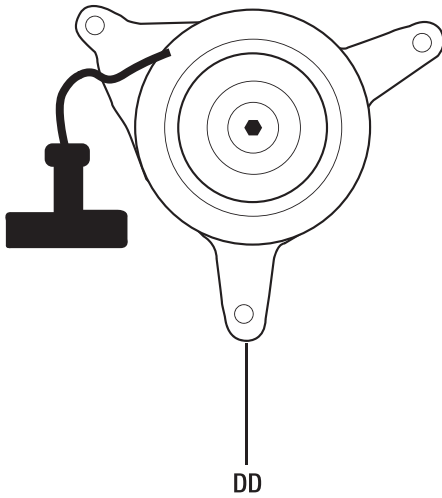
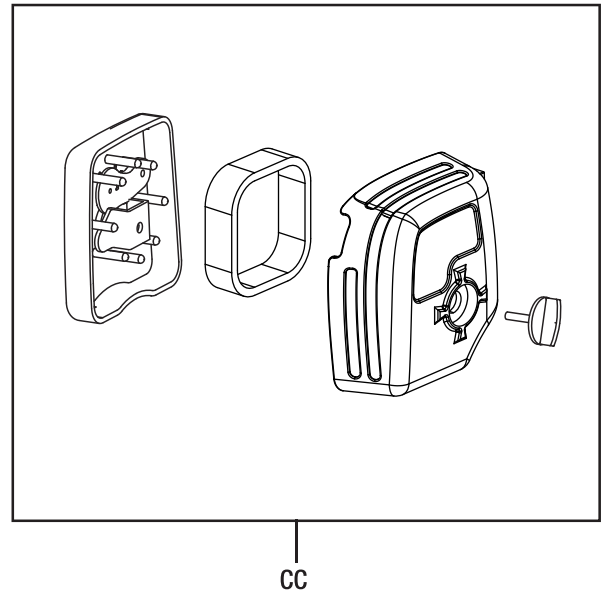
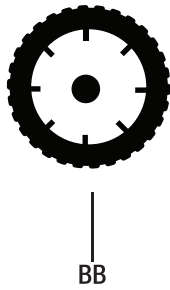
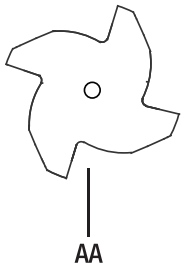













Gasoline Engine Instruction Manual

MODEL: YJ1E44FN



WARNING Read this operator manual carefully before the first use.

DESCRIPTION OF THE SYMBOLS

| | |
|---|--|
|  | <p>Read the instruction handbook and follow all warning and safety instructions Before any use, refer to the corresponding paragraph in the present manual.</p> |
|  | <p>Complies with European regulations applicable to this product.</p> |
|  | <p>The exhaust and exhaust gases are hot.</p> |
|  | <p>Danger of injury from flying parts! Always maintain a sufficiently safe distance. Beware of thrown objects. The distance between the machine and bystanders should be at least 15 meters.</p> |
|  | <p>Start engine creates sparking. Sparking can ignite nearby flammable gases.</p> |
|  | <p>Engines give off carbon monoxide, an odorless, colorless, poison gas. Breathing carbon monoxide can cause nausea, fainting or death.</p> |
|  | <p>Strictly no naked flames or smoking near the appliance!</p> |
|  | <p>Push the bubble 6times before use to make sure the fuel full of the oil way</p> |
|  | <p>Choke closed.</p> |
|  | <p>Choke open</p> |

SAFETY WARNINGS

Training

- a) Read the instruction carefully. Be familiar with the controls and proper use of the equipment.
- b) Never allow children or people unfamiliar with these instructions to use the machine. Local regulations can restrict the age of the operator.
- c) Never work while people, especially children, or pets are nearby.
- d) Keep in mind that the operator or user is responsible for accidents or hazards occurring to other people or their property.

- e) Major repair work shall be carried out only by specifically trained personnel.
- f) All persons and animals must be kept at least 15 meters from the machine while it is working

Preparation

- a) **WARNING-Petrol is highly flammable:**
 - store fuel in containers specifically designed for this purpose;
 - refuel outdoors only and do not smoke while refueling;
 - add fuel before starting the engine. Never remove the cap of fuel tank or add petrol while the engine is running or when the engine is hot;
 - if petrol is spilled, do not attempt to start the engine but move the machine away from the area of spillage and avoid creating any source of ignition until petrol vapors have dissipated;
 - replace all fuel tank and container caps securely.
- b) Replace faulty silencers;
- c) Before using, always visually inspect to see that the tools are not worn or damaged. Replace worn or damaged elements and bolts in sets to preserve balance.
- d) Do not smoke near the machine.
- e) Do not wear loose clothing, jewellery, or similar items that could be caught in the starter or other moving parts.
- f) Never put any items into the ventilation openings. Non-observance may lead to injury, or damage to the machine.

Operation

- a) Do not operate the engine in a confined space where dangerous carbon monoxide fumes can collect.
- b) Keep the machine free of oil, dirt and other impurities.
- c) Please always place the appliance on even and stable surfaces.
- d) Never operate the appliance inside buildings or in an environment without proper ventilation. Pay attention to air flow and temperature.
- e) Do not operate or store the appliance in wet or humid surroundings.
- f) Ensure the sound absorber and air filter work properly. These parts serve as flame protection in case of misfire.
- g) To avoid possible burn injuries, do not touch the exhaust system or other parts that become hot during operation. Pay attention to the warnings on the

machine.

- h) The engine must not be operated with excessive rotary speed. The operation of the engine with excessive rotary speed raises the risk of injury. Parts which affect the rotary speed must not be altered or replaced.
- i) Regularly check for leakage or traces of abrasion in the fuel system, such as porous pipes, loose or missing clamps and damage to the tank or tank cap. Before use all defects must be repaired.
- j) Work only in daylight or in good artificial light.
- k) Never pick up or carry a machine while the engine is running
- l) Stop the engine:
 - whenever you leave the machine.
 - before refueling.
- m) Before checking or adjusting the machine, the ignition plug and the ignition wire respectively must be removed to prevent accidental starting.
- n) Do not use of the machine when the operator is tired, ill or under the influence of alcohol or the drugs.

Maintenance and storage

- a) Keep all nuts and screws tight to be sure the equipment is in safe working condition.
- b) Never store the equipment with petrol in the tank inside a building where fumes can reach an open flame or spark.
- c) Allow the engine to cool before storing in any enclosure.
- d) To reduce the fire hazard, keep the engine, silencer and petrol storage area free of vegetative material and excessive grease.
- e) Replace worn or damaged parts for safety.
- f) If the fuel tank has to be drained, this should be done outdoors.
- g) Always clean and maintenance before storage.
- h) Never disassembly the guards for cutting attachments.
- i) Always store the metal blade in cool and dry place, never use rusted blade. It may cause serious injure during working.

TECHNICAL SPECIFICATIONS

| | |
|---------------------------------|---|
| Engine model | YJ1E44FN |
| Type | Air-cooled, 2-stroke single cylinder, gasoline engine |
| Ignition System | Flywheel magneto with CDI |
| Starting system | Recoil starter |
| Bore x Stroke (mm) | 44*33 |
| Displacement (cm ³) | 50 |
| Maximum net power (kW) | 1.5/7500 |
| Volumes of fuel tank (gal) | 0.3 |
| Weight (kg) | 4 |

LIST OF MAIN PART

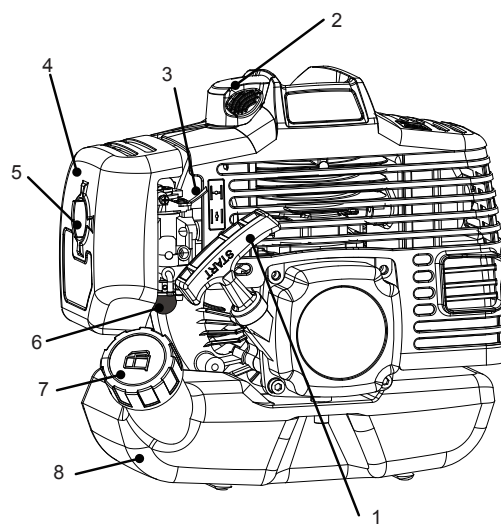

Fig.1

| | |
|-------------------|---------------------|
| 1. Starter handle | 2. Spark plug |
| 3. Air choke | 4. Air filter cover |
| 5. Knob | 6. Primer |
| 7. Fuel tank cap | 8. Fuel tank |

OPERATION

FUEL AND OIL RECOMMENDATIONS

WARNING!

Gasoline is extremely flammable and can be explosive under certain conditions, creating the potential for serious burns.

Turn the ignition switch to "O".

Do not smoke. Make sure the area is wellventilated and free from any source of flame or sparks; this includes any appliance with a pilot light.

Never fill the tank completely to the top.

If the tank is filled completely to the top, heat may cause the fuel to expand and overflow through the vents in the tank cap.

After refueling, make sure the tank cap is closed securely.

If gasoline is spilled on the fuel tank, wipe it off immediately.

WARNING!

2 STROKE GASOLINE ENGINE, use fuel mixed with oil only. 2 % oil (20 gr) per liter of green gas. Use only 2-stroke synthetic oil (type API-TC/JASO-FD/ISO-L-EGD/TISI) .Make sure fuel is mixed well before refueling. Always use fresh mixture.

Only fuel the machine in well-lit areas. Avoid fuel spillage. Never refuel the machine during operation. Let the engine cool down for about two minutes before refueling.

Refueling must not be carried out near naked flames, control lamps or spark producing electrical equipment such as electric tools, welders or sanders.

1. Make sure the machine is turned off, by turn the engine switch to the "O" position.
2. Check the fuel by a visual check , remove the fuel cap and reviewing the fuel level.
3. Full unleaded fuel mixed with oil from an approved fuel container into the fuel tank, because of fuel expands, please fill the tank to the neck of tank only.
4. Turn the fuel cap clockwise to assembly it in position.

WARNING !

- Do not refill fuel while engine is running or hot.
- Make sure fuel is not leaking.

Use quality two-stroke oil and make a mixture of 50 parts petrol to one part oil only **(2% oil mixed in fuel)**.

Never use two-stroke oil intended for water-cooled engines.

Never use oil intended for four-stroke engines.

A poor oil quality and/or too high oil/fuel ratio may jeopardise function and decrease the life time of catalytic converters.

Shake the container well to obtain a correct mixture before filling the tank.

Throttle Cable Adjustment

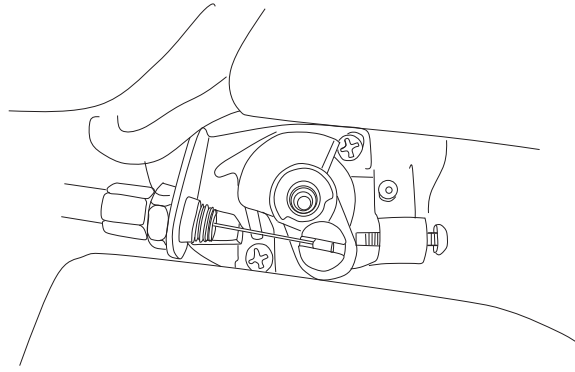

When setting the engine to equipment (brush cutter. etc.), adjust the throttle cable in the following procedures:

1. Remove the air cleaner cap. Loose the lock nut.
2. Turn the adjusting screw. Be sure that the Idle screw touches throttle plate at the swivel and the play of the throttle cable is around 2 mm.
3. Squeeze the throttle lever. Be sure that throttle plate touches the stopper.
4. Tighten the lock nut.

Starting the engine

To start a cold engine:

- 1) Move the air lever to the cold start position. 

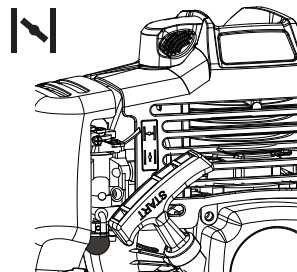

- 2) Place the switch in the position "I" (start)

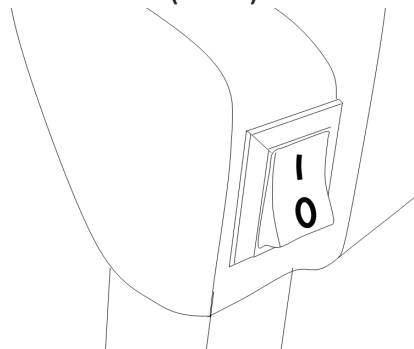

- 3) Press the primer bulb several times (7to10 times) until the fuel reaches the carburetor.

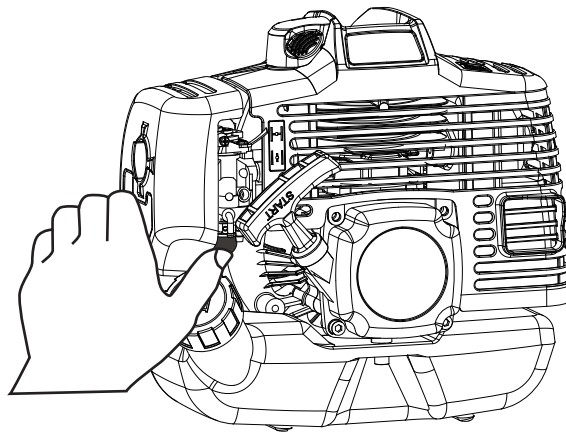

4) Move the ignition switch to the "On" position



5) Pull the starter rope until you hear the engine start.

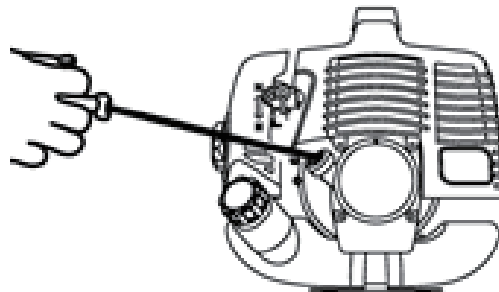

6) Move the air lever to the normal working position. |||

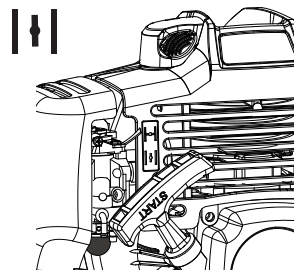

7) If the engine exploded but did not actually start running, pull the start rope again until it starts.

Allow the engine to warm up for approximately one minute before starting to work

with the machine.

To start a warm engine:

1. Move the switch to the “I” position.
2. Move the lever to the  position
3. Pull the start rope until the machine starts.

If the machine does not start after pulling at the rope a few times, please refer to the cold start up section.

To stop the engine:

1. Let go of the accelerator and let the engine run at idle speed for a few seconds.
2. Stop the engine by displacing the switch from the position to the “O” position (stoppage)

MAINTENANCE

WARNING ! Prevent accidental starting during engine service by removing the spark plug cap.

| Maintenance | Daily | First 20 hours | Every 20 hours | Every 50 hours | Every 100 hours |
|--|-------|----------------|----------------|----------------|-----------------|
| Check and replenish fuel | X | | | | |
| Check for fuel leakage | X | | | | |
| Check bolts, nuts and screws for looseness and loss | X | | | | |
| Clean fuel filter | | | X | | |
| Clean fuel tank cap | | | X | | |
| Clean air filter element | | | X | | |
| Tighten bolts, nuts and screws | X | | | X | |
| Clean spark plug and adjust electrode gap | | | | X | |
| Remove dust and dirt from cylinder fins | | | | X | |
| Remove carbon deposits on piston head and inside cylinder | | | | X | |
| Remove carbon deposits in the exhaust pipe of muffler | | | | X | |
| Clean screen of spark arrester | | | | X | |
| Check the sliding portion of crankshaft, connecting rod etc. | | | | | X |



- The service intervals indicated are to be used as a guide. Service to be performed more frequently as necessary by operating condition.
- When damage or defect occurs in checked parts, replace with a new one.

Replacing and cleaning air filter

For proper performance and long life, keep air filter clean.

- ◆ Remove the air filter cover by unscrewing the screw on the air filter cover.
- ◆ Remove the filter, clean it in warm soapy water. Rinse and let dry completely. For best performance, replace annually.

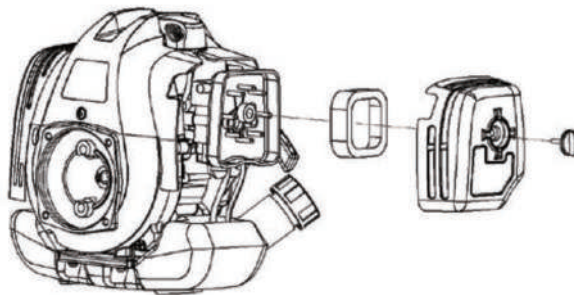

WARNING:

The use of petrol or combustible solvents for cleaning can cause fire or explosion. Therefore only use soap water or non-combustible solvent. Never operate the machine without the air filter.

Spark plug

To ensure proper engine operation, the spark plug must be properly gapped and free of deposits.

1. Remove the spark plug cap.
2. Clean any dirt from around the spark plug base.
3. Use the socket spanner which provided to remove the spark plug.
4. Visually inspect the spark plug. Remove carbon deposits using a wire brush.
5. Check for discoloration on the top of the spark plug. The standard color should be a tan color.
6. Check the spark plug gap. The acceptable gap should be between 0,6-0,7mm.

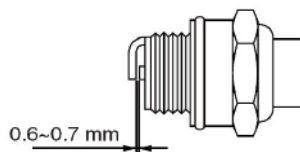

7. Install /reinstall the spark plug carefully by hand.
8. Once the spark plug has been seated, tighten it with a spark plug wrench.
9. Reinstall the spark plug cap on top of the spark plug.

Adjusting of carburetor

The carburetor is tuned by the manufacturer to achieve maximum performance in all situations, with a minimum emission of toxic gas in compliance with the regulations in force. In the case of poor performance contact your Dealer for a check of the carburetion and engine.

TROUBLESHOOTING GUIDE

| | Symptom | Probable Cause | Remedy |
|-------------------------------------|---------------------------------------|---|---|
| Engine won't start or output is low | Insufficient compression | Fault Piston, Cylinder or Piston ring | Ask your distributor for advice |
| | | Loose spark plug | Tighten properly. |
| | | Loose cylinder bolts | |
| | No fuel to combustion chamber | No Fuel in fuel tank | Fill fuel tank. |
| | | Blocked fuel filter or tube | Clean. |
| | | Blocked air vent in tank cap | |
| | | Faulty carburetor | Ask your distributor for advice |
| | Spark plug fouled by fuel | Over-rich fuel/air mixture | Clean spark plug. |
| | | Clogged air cleaner | Clean |
| | | Faulty carburetor | Ask your distributor for advice |
| | | Incorrect grade/type of fuel | Change gasoline. |
| | | Water in fuel | |
| | No spark or weak park | Faulty spark plug | Replace spark plug. |
| | | Faulty ignition coil | Ask your distributor for advice |
| | | Engine switch left in "STOP" position | Turn engine switch to "START" position. |
| Low output | Engine overheats | Clogged air cleaner | Clean |
| | | Recoil starter or cooling air path clogged with dirt. | |
| | Carbon built-up in combustion chamber | Ask your distributor for advice | |
| | Poor ventilation around engine | Select a better location. | |

STORAGE

Empty the fuel

Engine to be stored over 30 days should be completely drained of fuel to prevent gum deposits forming on essential carburetor parts fuel filter and fuel tank.

- Clean the engine.
- Remove all the fuel from the tank and run the engine at idling to use up the fuel in the carburetor.
- Remove the spark plug, pour in 0.5 mL of new 2- stroke engine oil through the plug hole, pull the recoil starter grip several times, and reinstall the spark plug.
- Slowly pull the recoil starter grip until resistance is felt.
- Store the engine in a clean and dry place.