

REGO

Lithium Iron Phosphate Battery

12V | 400Ah

VERSION A0

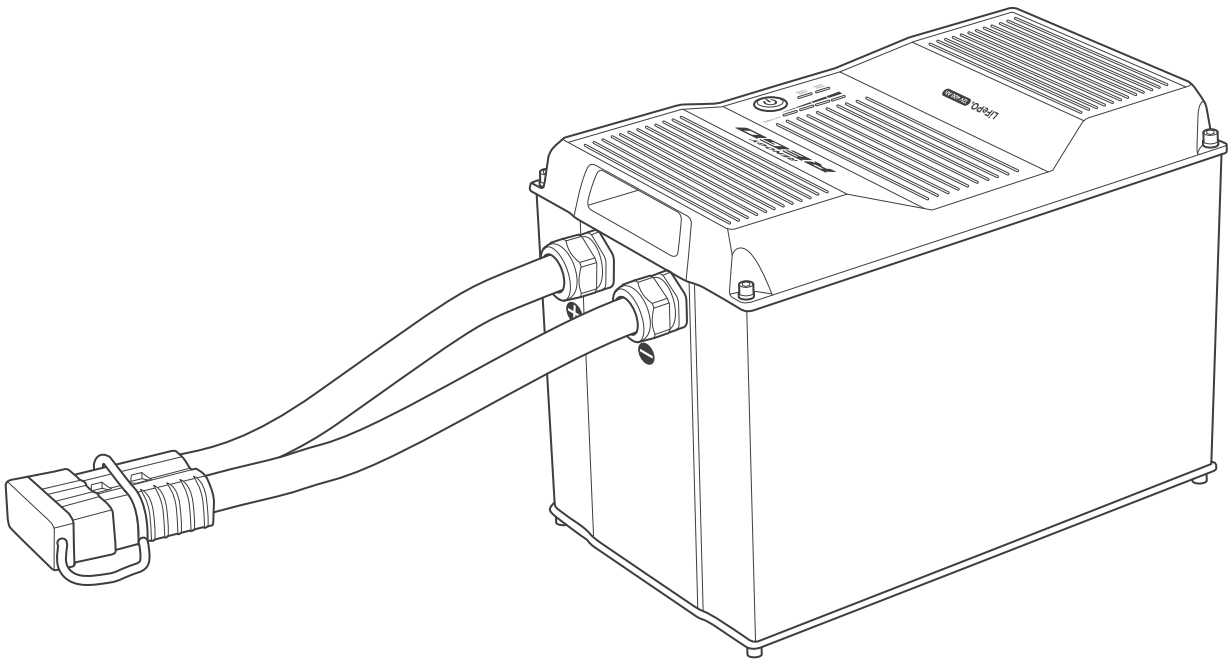

USER MANUAL

Applicability

The user manual applies to the following product:

- REGO 12V 400Ah Lithium Iron Phosphate Battery (RBT12400LFPL-SHBT)

Disclaimer

- Renogy makes no warranty as to the accuracy, sufficiency, or suitability of information in the user manual because continuous product improvements are going to be made.
- Renogy assumes no responsibility or liability for losses or damages, whether direct, indirect, consequential, or incidental, which might arise out of the use of information in the user manual.
- Renogy is not responsible or liable for the failures, damages, or injuries resulting from repair attempted by unqualified personnel or improper installation and operation.
- The illustrations in the user manual are for demonstration purposes only. Details may appear slightly different depending on product revision and market region.
- Renogy reserves the right to change the information in the user manual without notice.

Copyright

REGO 12V 400Ah Lithium Iron Phosphate Battery User Manual © 2022 Renogy. All rights reserved.

All information in the User Manual is subject to copyright and other intellectual property rights of Renogy and its licensors. The User Manual may not be modified, reproduced, or copied, in whole or in part, without the prior written permissions of Renogy and its licensors.

Trademarks

The following are trademarks or registered trademarks of Renogy in the United States and other countries and regions:

RENOGY	RENOGY	RENOGY REGO	RENOGY REGO
--------	---------------	-------------	------------------------

All other trademarks in the user manual are the property of their respective owners and their use herein does not imply sponsorship or endorsement of their products or services. The unauthorized use of any trademark displayed in the user manual or on the product is strictly prohibited.

Date and Revision

June 2022, Revision A0

Table of Contents

Important Safety Information	05
Symbols Used	05
General Safety Information	05
Introduction.....	07
Introduction	07
Key Features	07
Package Contents	09
Product Overview	10
Wiring Diagram.....	11
Using Combiner Boxes	11
Using Busbars	11
Installation	12
Inspection	12
Environment.....	12
Placement	12
Mounting	13
Power Connection	15
Using Combiner Boxes	15
Using Busbars	18
Communication.....	20
Inter-Device Communication.....	20
Monitoring Device Communication	23
Commission.....	27
Indicator Pattern	27
Turning On	27
Checking Battery Level	29

Checking Battery Status.....	30
Checking Heater Status	31
Changing Heater Settings	33
Charging.....	34
Discharging	35
Turning Off	35
Maintenance	37
Inspection.....	37
Cleaning	37
Storage.....	37
Battery Management System	39
Warning/Protection/Permanent Failure	39
Charge Current Request	42
Cell Voltage Balancing	42
Troubleshooting	43
Emergency Responses	52
Fire	52
Flooding	52
Smell	52
Technical Support.....	53
Technical Specifications	54
Dimensions.....	56



Important Safety Information





Symbols Used

General Safety Information

The User Manual provides important installation, operation, and maintenance instructions for REGO 12V 400Ah Lithium Iron Phosphate Battery. Please read the User Manual carefully before installation and operation and save it for future reference. Failure to observe the instructions or precautions in the User Manual can result in electrical shock, serious injury, or death, or can damage the battery, potentially rendering it inoperable.

Symbols Used

The following symbols are used throughout the User Manual to highlight important information:

	WARNING	Indicates a potentially dangerous condition which could result in injury or death.
	CAUTION	Indicates a critical procedure for safe and proper installation and operation.
	NOTE	Indicates an important step or tip for optimal performance.
	INFO	Indicates that more information is available in other documents relating to the subject.

General Safety Information



WARNING

- DO NOT puncture, drop, crush, penetrate, shake, strike, or step on the battery.
- DO NOT open, dismantle, repair, tamper with, or modify the battery.
- DO NOT touch the connector contacts of the battery.
- Please remove all connections and turn the battery off before maintenance or cleaning.
- Please install the battery in accordance with the regulations at the site of installation.
- DO NOT expose the battery to direct flame.
- Please keep the battery away from flammable or combustible materials.
- DO NOT expose the battery to harsh chemicals or vapors.
- Please keep the battery away from heating equipment.
- DO NOT touch the exposed electrolyte or powder if the battery is damaged.
- DO NOT use the battery with life support equipment or other medical equipment.
- Please keep the battery out of the reach of young children and animals.
- Please use insulated tools when working on or around the battery.
- DO NOT wear jewelry or other metal objects when working on or around the battery.
- Please wear proper protective equipment when working on or around the battery.

Important Safety Information

Symbols Used

General Safety Information



CAUTION

- Ensure adequate and secure mounting of the battery.
- DO NOT expose the battery to strong electrostatic fields, strong magnetic fields, or radiation.
- Please use suitable handling equipment for safe transportation of the battery.
- Ensure that no water sources are above or near the battery, including downspouts, sprinklers, or faucets.
- Ensure that snow does not accumulate around the battery.
- DO NOT lean on, stack anything on top of, or hang anything from the battery or from cables leading to the battery.

Introduction

Meet the next era of energy storage system with Renogy 12V 400Ah REGO Lithium Iron Phosphate Battery. With a large capacity of more than 5KWh, the battery is designed to run loads for extended periods of time. Manufactured with top grade cells, the battery provides an exceptional lifespan of more than 3800 cycles (80% DOD), a continuous discharge current up to 350A for heavy loads, and a continuous charge current up to 300A for 1.5-hour fast charging. The integrated battery cables and Anderson connector significantly simplify the wiring, reduce the risk of short circuit, misconnection, and connection failure, and allow for quick connection and disconnection. The sophisticated battery management system (BMS) offers up to 60 types of warnings and protections, enables precise cell balancing, and stores up to 150 event records. The built-in heater operates automatically at low temperatures to keep the battery charging. The straightforward LED indicators visualize the battery level, battery status, and heater status. The on-board Bluetooth module ensures real-time monitoring on DC Home app and compatible monitoring devices. The RV-C protocol compatibility allows for complete system integration, featuring better charging experience, safer operation, and more customizable settings to extend the lifespan of the battery. The waterproof die cast aluminum housing and stringent road load tests ensure that the battery can deliver extreme performance even under the harshest conditions including wet environments and mechanical vibrations.

Key Features

- **Large Capacity**

Runs loads for extended periods of time with a capacity of more than 5KWh.

- **Uncompromising Quality**

Provides an exceptional lifespan of more than 3800 cycles (80% DOD), a continuous discharge current up to 350A, and a continuous charge current up to 300A.

- **Easy Installation**

Makes wiring simple and safe with the integrated battery cables and Anderson connector.

- **Advanced BMS**

Offers comprehensive protection, precise balancing, and event logging capability with the state-of-the-art battery management system (BMS).

- **Built-In Heater**

Warms the battery up automatically at low temperatures for continuous charging with the built-in heater.

- **Visualized Status**

Visualizes the battery level, battery status, and heater status with the straightforward LED indicators.

- **Remote Monitoring**

Ensures real-time monitoring on DC Home app and compatible monitoring devices with the on-board Bluetooth module.

Introduction

Introduction

Key Features

- **RV-C Compatible**

Allows for complete system integration for better charging experience, safer operation, and more customizable settings with the RV-C protocol compatibility.

- **Reliable Design**

Delivers extreme performance even under the harshest conditions with the waterproof die cast aluminum housing.

Package Contents

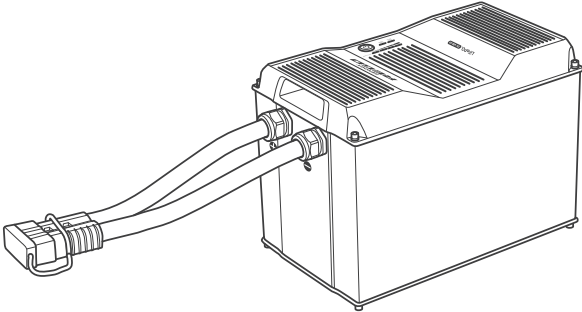
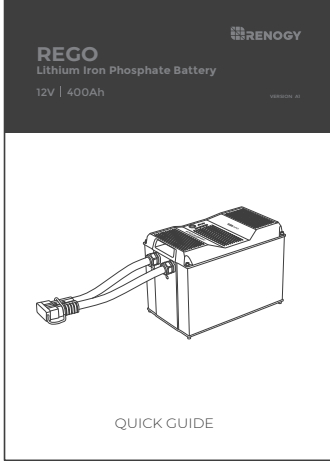
12V 400Ah REGO Lithium Iron Phosphate Battery × 1	Quick Guide × 1
	

Product Overview

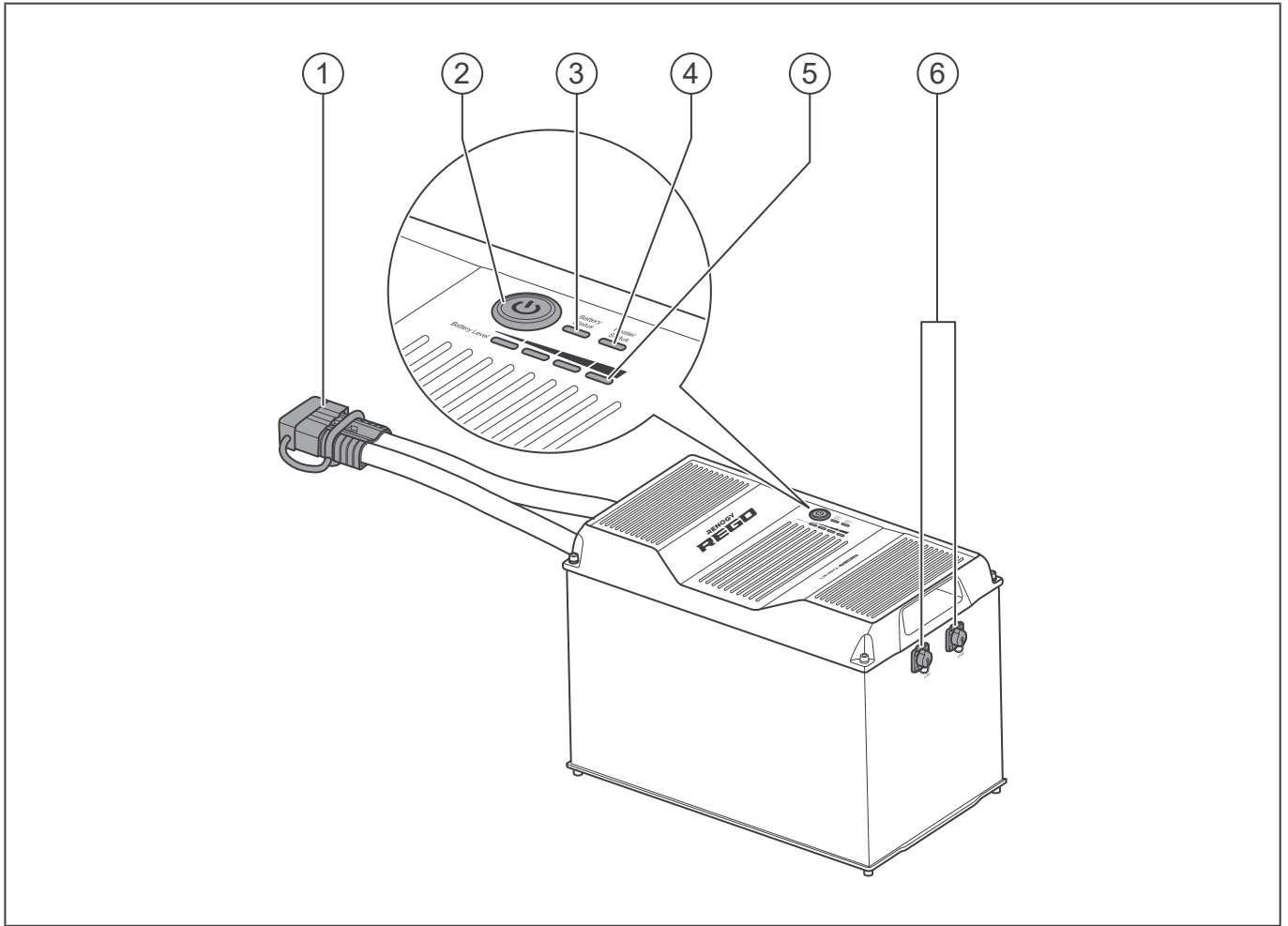

No.	Part	No.	Part
1	Gray Anderson 350 Connector (with Dust Cover)	4	Heater Status Indicator
2	Power Button	5	Battery Level Indicator
3	Battery Status Indicator	6	CAN Communication Ports

Wiring Diagram

Using Combiner Boxes

Using Busbars

Using Combiner Boxes

Single Battery

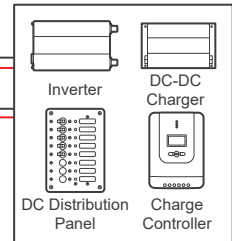
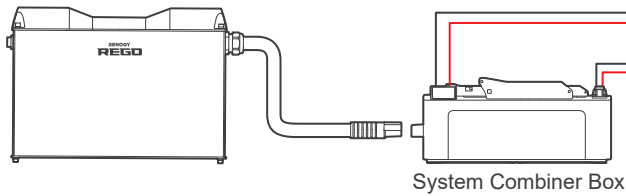

Multiple Batteries

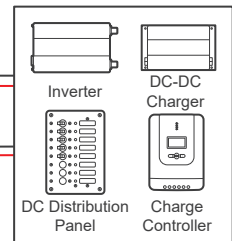
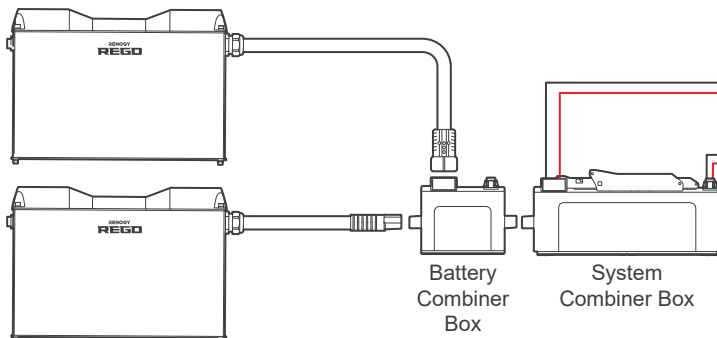

— Positive — Negative

Using Busbars

Single Battery

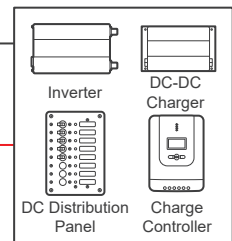
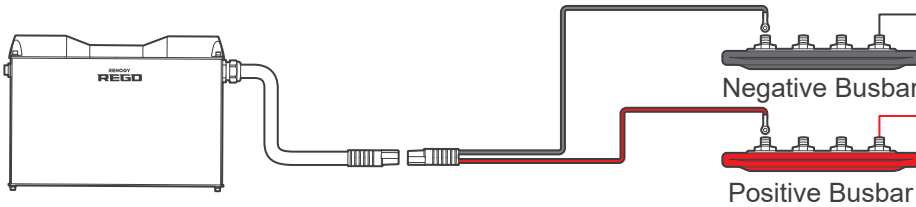

Multiple Batteries

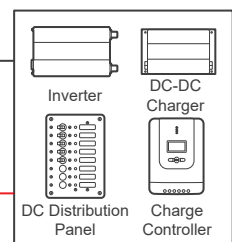
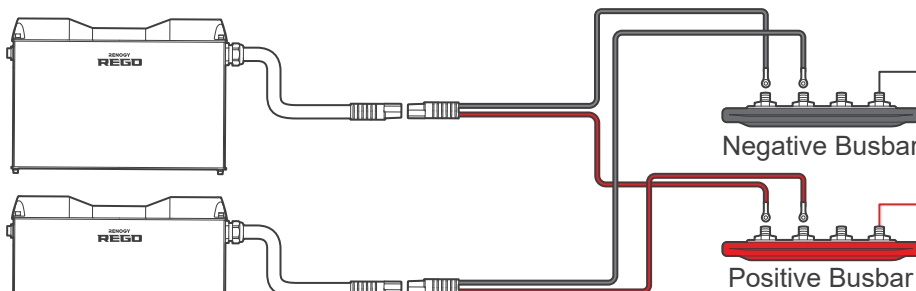

— Positive — Negative

Installation

Inspection

Environment

Placement

Mounting

Inspection

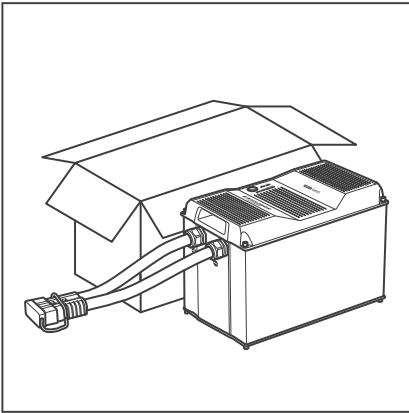

Inspect the battery for any visible damages including cracks, dents, deformation, and other visible abnormalities before installation. The connector contacts shall be dry, clean, and free of any dirt and corrosion.

WARNING

- DO NOT use the battery if it appears damaged.

Environment

Ensure that the installation environment is clean, cool, and well-ventilated. Keep the battery away from oil and dirt. The accumulation of these substances can cause current leakage, resulting in self-discharge and a possible short circuit. Avoid restricting airflow by tightly packing batteries together. Allow at least 0.5 inches (12.7 mm) of space between the batteries for efficient heat dissipation and minimal battery temperature variations. Safe operation requires environment temperatures between -4°F (-20°C) and 122°F (50°C). The recommended operating environment temperature range is 59°F (15°C) and 86°F (30°C).

Placement

Place the battery upright or horizontally on the long side.

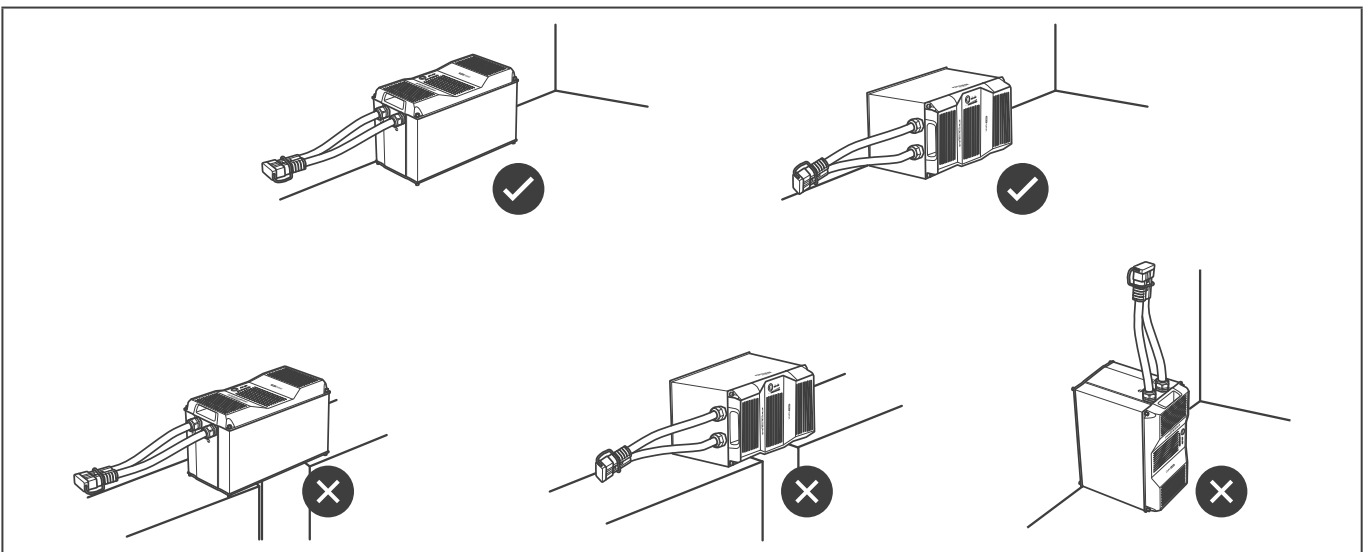

Installation

Inspection

Environment

Placement

Mounting



CAUTION

- DO NOT place the battery upside down or horizontally on the short side.
- Ensure that the battery is fully supported.

Mounting

Recommended Tool and Accessories

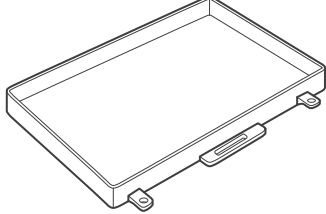
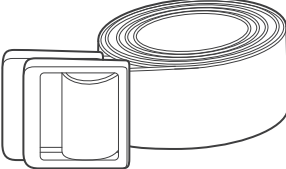
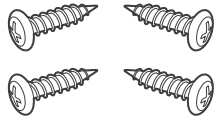
Phillips Screwdriver	Battery Tray
	
Tie Down Strap	Mounting Screws
	

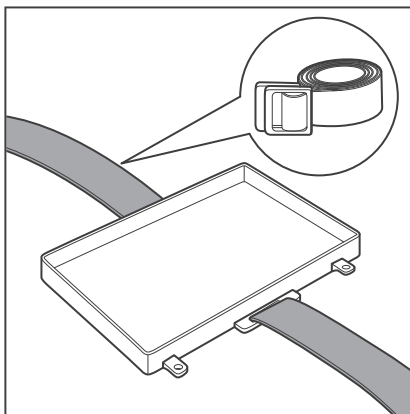

1. Thread the Tie Down Strap through the strap anchors on the Battery Tray.

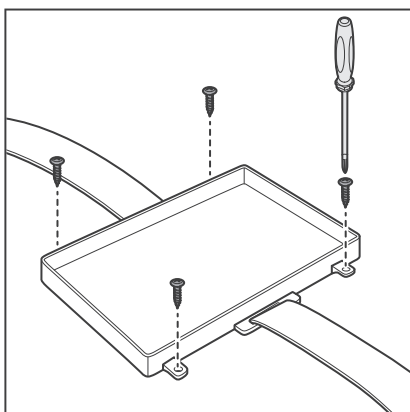

2. Secure the Battery Tray on a flat mounting surface with the Mounting Screws. Tighten the Mounting Screws with the Phillips Screwdriver.

i NOTE

- It is recommended to pre-drill holes on the mounting surface with a drill and a drill bit before mounting the Battery Tray.

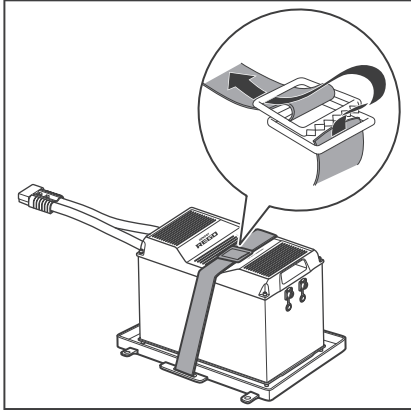

3. Place the battery into the Battery Tray. Buckle the Tie Down Strap over the battery.

i NOTE

- Alternative mounting methods are allowed to meet the requirements of specific applications.

Power Connection

Using Combiner Boxes

Using Busbars

The batteries can be connected in parallel and to the system with either combiner boxes or busbars. Parallel connection is intended to increase the battery bank capacity while keeping the battery bank voltage the same.

WARNING

- DO NOT short the contacts of the Anderson Connector. Short circuits can damage the battery.
- DO NOT connect batteries in series. Series connection can damage the batteries.
- DO NOT mix battery brands, models, chemistries, nominal voltages, and rated capacities.

CAUTION

- Please check the polarity before connecting the cables. Reverse polarity can damage the battery and connected devices.
- The Anderson Connectors are color coded. DO NOT mate the Anderson Connectors with different colors together.
- DO NOT connect more than 8 batteries in parallel.
- Please avoid large voltage difference between batteries connected in parallel.

Using Combiner Boxes

Connecting the batteries in parallel and to the system using the Battery Combiner Box and the System Combiner Box significantly reduces the risk of short circuit, misconnection, or connection failure and allows for quick connection and disconnection.

Required Accessories

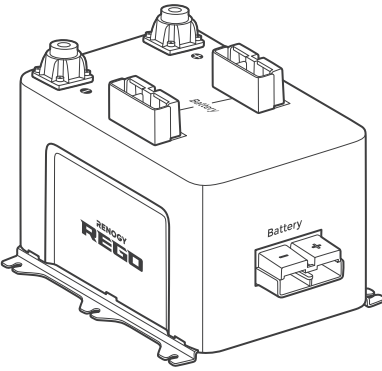
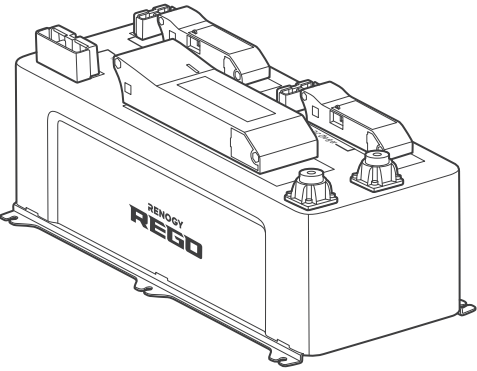
REGO 3 Ports 400A Battery Combiner Box(es)	REGO 4 Ports 400A System Combiner Box
 A line drawing of a rectangular battery combiner box. It has three Anderson connectors on top and one on the front. The front connector is labeled 'Battery'. The box has 'REGO' and 'REGO' logos on its side.	 A line drawing of a rectangular system combiner box. It has four Anderson connectors on top and two on the front. The box has 'REGO' and 'REGO' logos on its side.

INFO

- Please read the user manual of REGO 3 Ports 400A Battery Combiner Box and REGO 4 Ports 400A System Combiner Box at renogy.com before the connection.

Power Connection

Using Combiner Boxes

Using Busbars

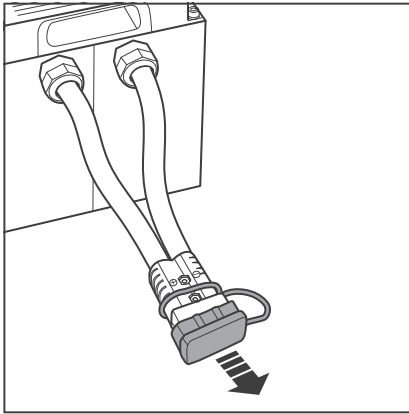

1. Remove the Dust Covers from the Anderson Connectors. If multiple batteries are to be connected in parallel, refer to [step 2](#) to [step 4](#). If only one battery is used, refer to [step 5](#).

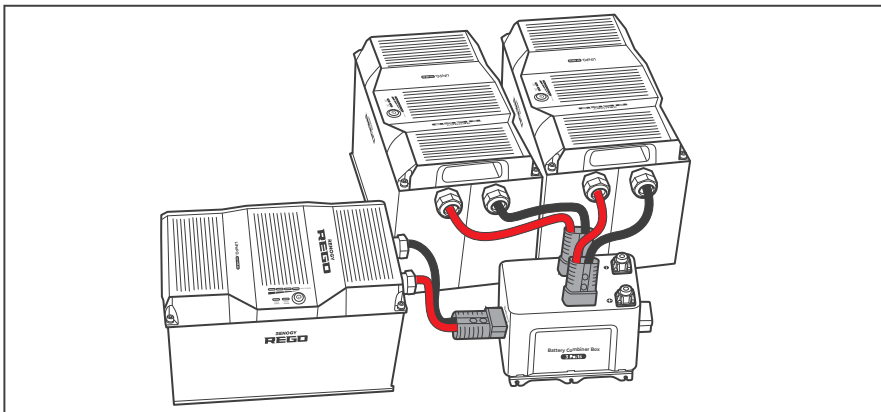

2. If multiple batteries are to be connected in parallel, plug the Anderson Connectors of the batteries to the Battery Combiner Box (sold separately).

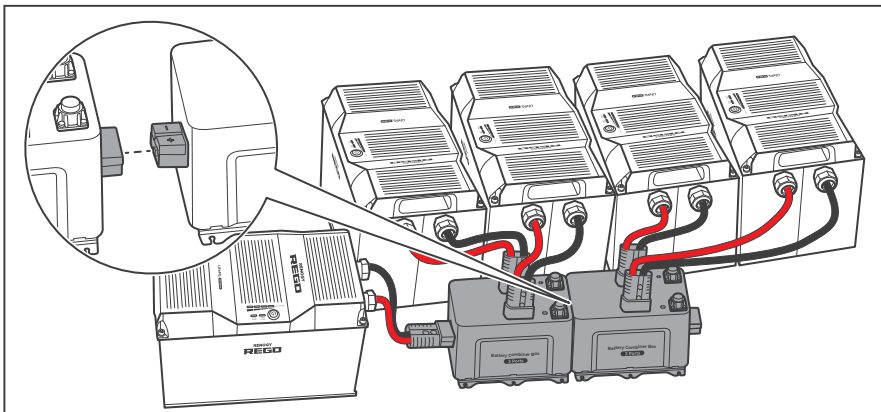

3. If necessary, connect multiple Battery Combiner Boxes together to accept more batteries in parallel.

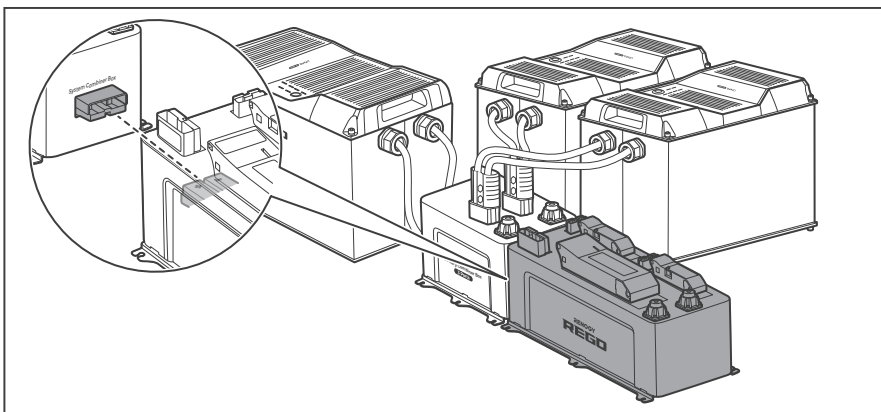

4. Connect the Battery Combiner Box and the System Combiner Box (sold separately) using the Anderson connectors on their sides.

Power Connection

Using Combiner Boxes

Using Busbars

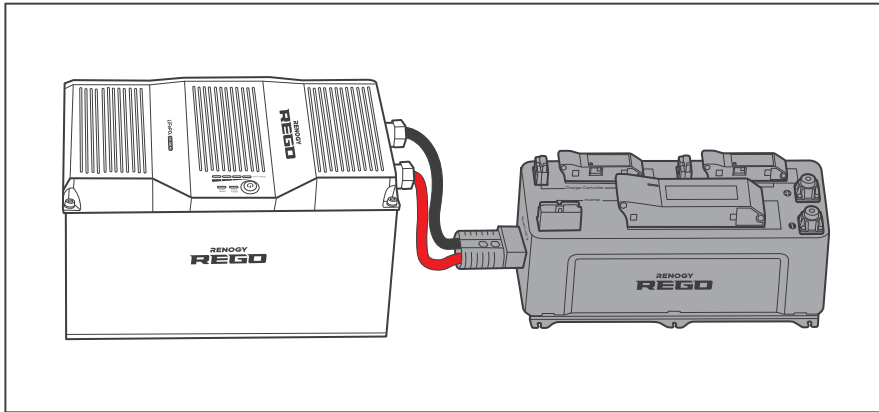

5. If only one battery is used, connect the battery directly to the Anderson connector on the side of the System Combiner Box.

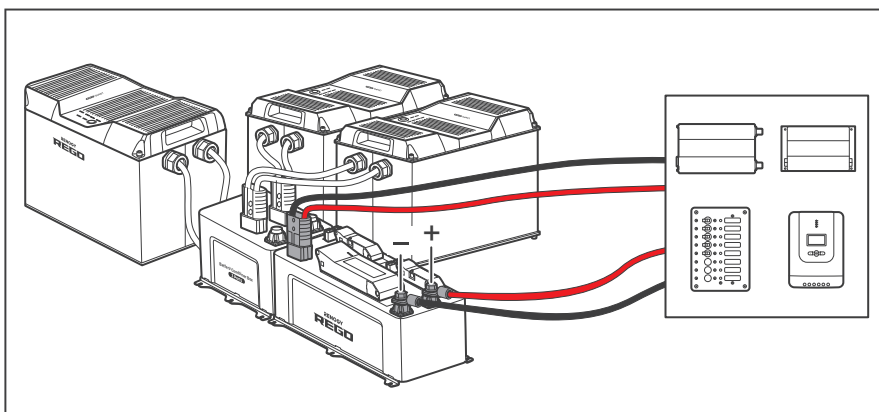

6. Connect the devices to the corresponding Anderson connectors or insert terminals on the top of the System Combiner Box.

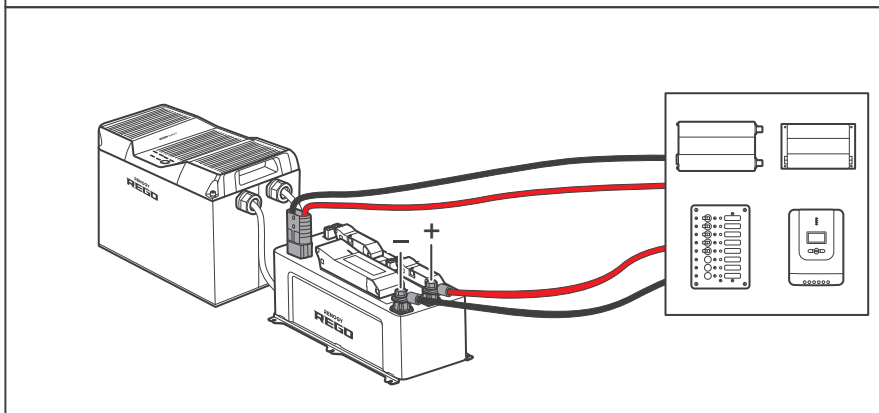

WARNING

- Please size the device cables appropriately to handle the expected current. Refer to the user manuals of the connected devices for more instructions.
- If the devices are connected to the Anderson connectors of the System Combiner Box, please install appropriately sized NH fuses (sold separately) in the System Combiner Box to protect connected devices and circuit wires. Refer to the user manual of the REGO 4 Ports 400A System Combiner Box for more instructions.
- If the devices are connected to the insert terminals of the System Combiner Box, please install appropriately sized fuses or circuit breakers in the branch circuits to protect connected devices and circuit wires. Refer to the user manuals of the connected devices for more instructions.
- Please ensure that the Anderson Connectors are fully seated and/or the ring terminals are

Power Connection

Using Combiner Boxes

Using Busbars

secured to the proper specification.

Using Busbars

Required Accessories

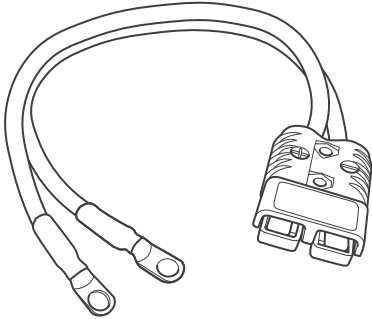
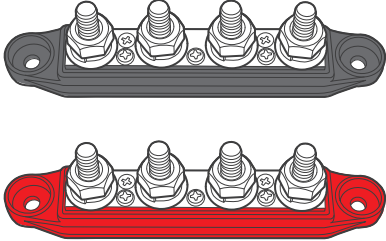
Gray Anderson 350 Connector to Ring Terminal Adapter Cable(s)	Positive/Negative Busbars
	



WARNING

- DO NOT short the positive and negative ring terminals of the Adapter Cable(s). Short circuits can damage the battery.

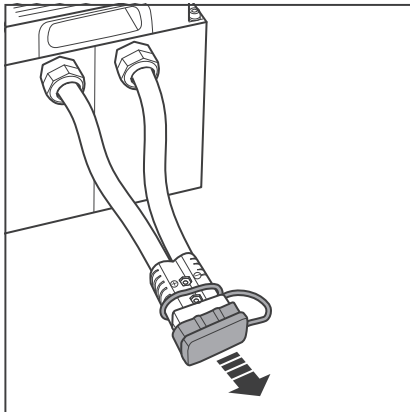

1. Remove the Dust Cover(s) from the Anderson Connector(s).

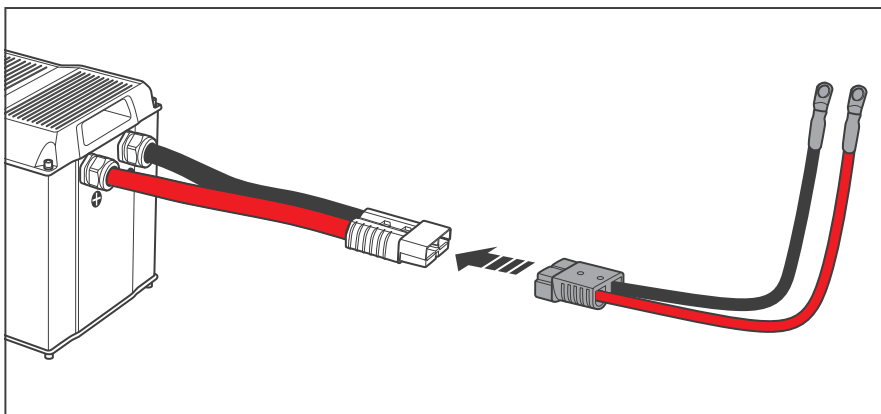

2. Connect the Anderson Connector(s) of the battery(ies) to the Adapter Cable(s) (sold separately).

Power Connection

Using Combiner Boxes

Using Busbars

WARNING

- Please size the Adapter Cable(s) appropriately to handle the expected current. Refer to Appendix for more instructions.

CAUTION

- If multiple batteries are to be connected in parallel, please ensure equal length of the Adapter Cables to make the batteries operate equally together.

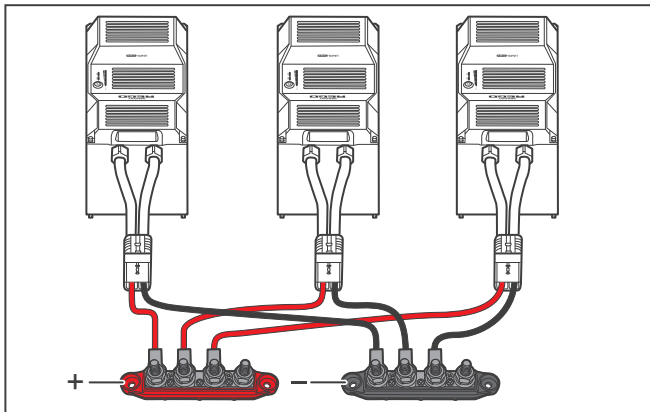

3. Connect the positive and negative ring terminals of the Adapter Cable(s) to the Positive and Negative Busbars (not included) respectively.

WARNING

- Please size the Busbars appropriately to handle the expected current. Refer to Appendix for more instructions.

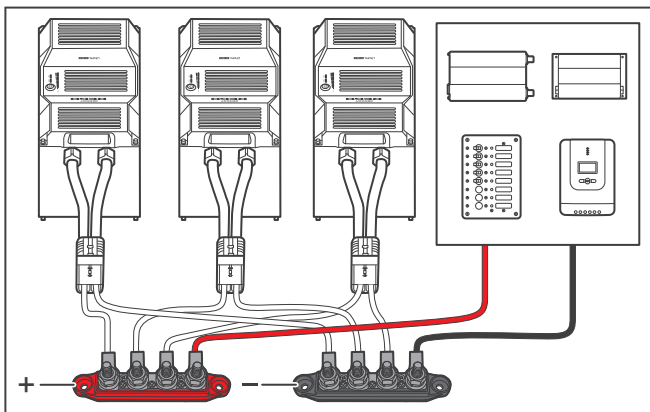

4. Connect the devices to the Positive and Negative Busbars.

WARNING

- Please size the device cables appropriately to handle the expected current. Refer to the user manuals of the connected devices for more instructions.
- Please install appropriately sized fuses or circuit breakers in the branch circuits to protect connected devices and circuit wires. Refer to the user manuals of the connected devices for more instructions.
- Please ensure that the Anderson Connector(s) is fully seated and/or the ring terminals are secured to the proper specification.

Communication

The communication connection is optional. It allows the battery to communicate with other REGO devices and monitoring devices, enabling safe operation, smart control, remote monitoring, and programmable settings.

Inter-Device Communication

Depending on the installation condition, the communication connections between the battery and other REGO devices can be established with backbone or daisy chain topology. The inter-device communication allows the battery to dynamically adjust the charging profile for an optimal and safe charge.

Backbone Topology

If an RV-C bus is pre-installed in the RV, follow the backbone topology for the inter-device communication connections.

Required Accessories

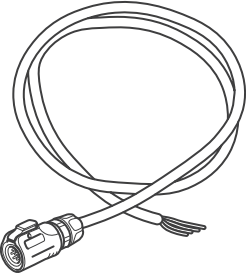
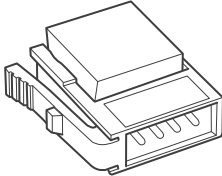
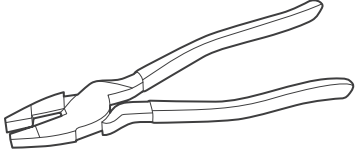
LP16 Plug (7-Pin) to Bare Wires Drop Cables	Drop Plugs	Split Joint Pliers
		

CAUTION

- The lengths of the Drop Cables shall not exceed 19.6 feet (6 m), and the total length shall not exceed 98.4 feet (30 m).

NOTE

- Please check the network wiring diagram provided by the RV manufacturer before connection.

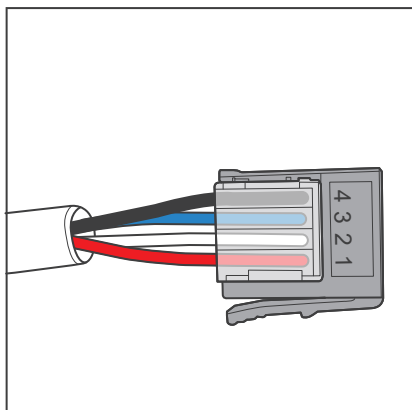

1. Insert the bare wires of the Drop Cables (sold separately) all the way into the wire ports of the Drop Plugs (not included) following the Drop Plug pinout. The red PS+ wires go to pin 1, the white CAN_H wires go to pin 2, the blue CAN_L wires go to pin 3, and the black PS- wires go to pin 4.

Communication

i NOTE

- Different drop sockets are used on the RV-C bus by different RV manufacturers. Please select the Drop Plugs that match the drop sockets for the inter-device communication connections. If unsure about the Drop Plug selection, please check with the RV manufacturer. This User Manual takes the Mini-Clamp II plug (4-pin) as an example.
- Different Drop Plugs follow different pinouts. Please crimp the Drop Plugs on the Drop Cables following the correct pinout. If unsure about the Drop Plug pinout, please check with the RV manufacturer. This User Manual takes the pinout of the Mini-Clamp II plug (4-Pin) as an example.

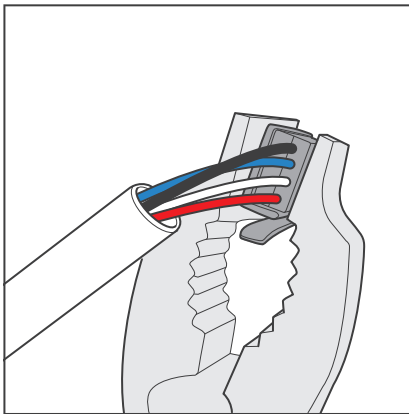

2. Squeeze the crimp areas of the Drop Plugs with the Split Joint Pliers.

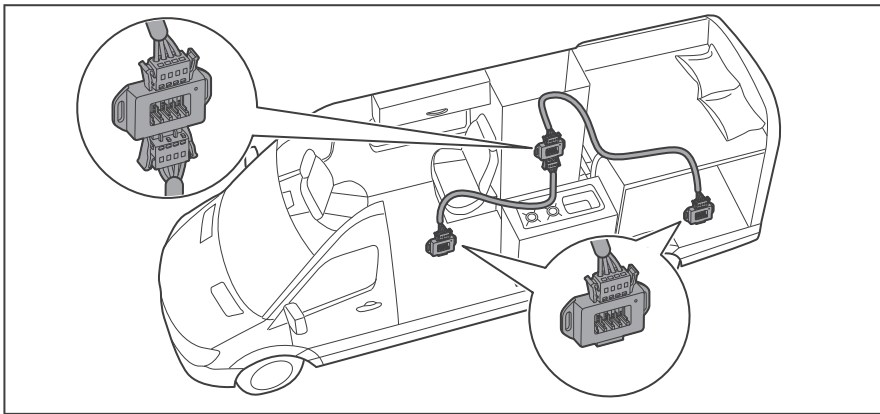

3. Locate the drop tap (not included) on the RV-C bus that is the closest to the battery installation location. The drop taps are usually located above the entry door, in the bathroom, or under the bed in the RV.

! CAUTION

- Please ensure that the drop taps at both ends of the RV-C bus are properly terminated with built-in 120Ω resistors.

i NOTE

- Different drop taps are used on the RV-C bus by different RV manufacturers. This User Manual takes the 4-socket drop tap as an example.
- If unable to locate the drop taps, please contact the RV manufacturer for help.

Communication

Inter-Device Communication

Monitoring Device Communication

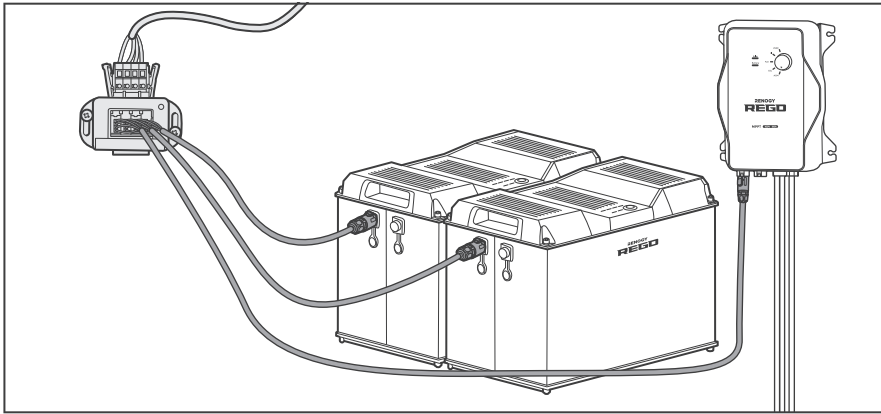

4. Connect either of the CAN Communication Ports of the battery and other REGO devices to the drop sockets on the drop tap with the Drop Cables.

Daisy Chain topology

If the RV-C bus is not available, follow the daisy chain topology for the inter-device communication connections.

Recommended Accessories

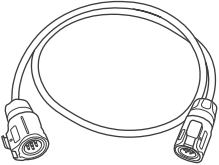
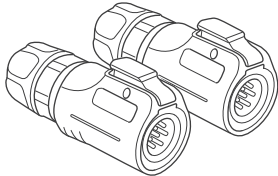
LP16 Plug (7-Pin) Communication Cable(s)	LP16 Terminator Plugs (7-Pin)
	

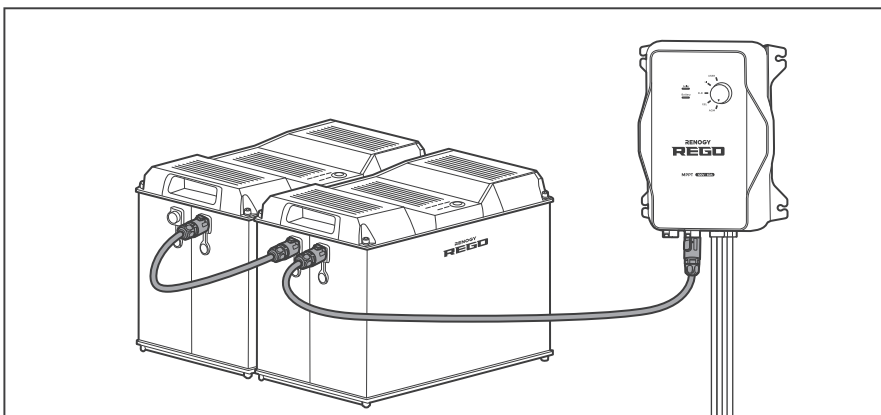

1. Connect REGO devices in series through either of the CAN Communication Ports with the Communication Cable(s) (sold separately).

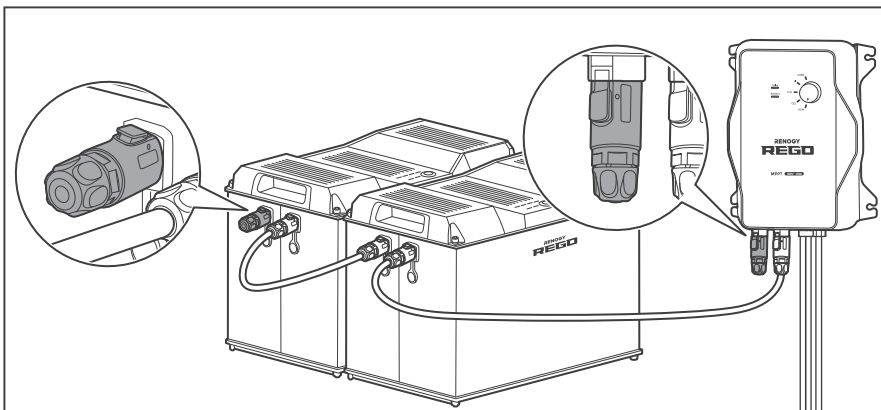

2. Plug the Terminator Plugs (sold separately) into the free CAN Communication Ports on the first and last REGO devices.

Monitoring Device Communication

Depending on the application, the short-range or long-range communication connections can be established between the battery and the monitoring devices. The monitoring device communication allows for the monitoring and programming of the battery or even the complete system.

NOTE

- Please scan the QR code on the [last page](#) of the User Manual to download the DC Home app.
- Please make sure that the battery is turned on before the connection. Refer to the [Turning On](#) section for more instructions.

Short-Range Monitoring

If only short-range monitoring is required, connect the battery to the DC Home app directly through Bluetooth.

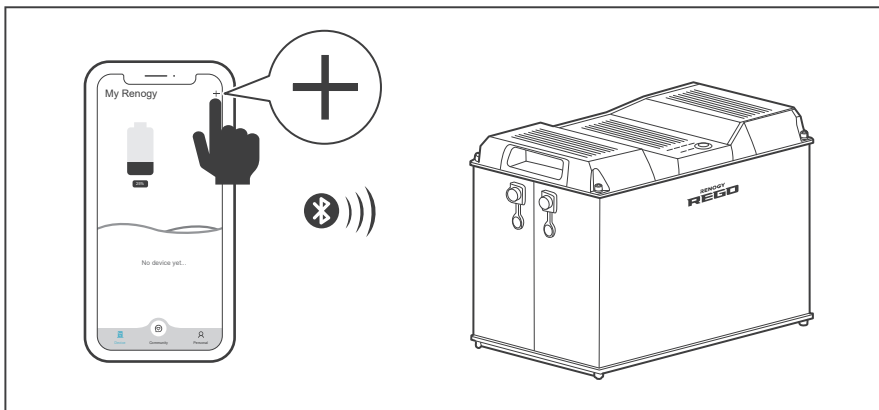

1. Open the DC Home app. Turn on the Bluetooth on the phone or tablet. Tap “+” on the top right corner to search for the battery. Wait for a few minutes until the battery is found.

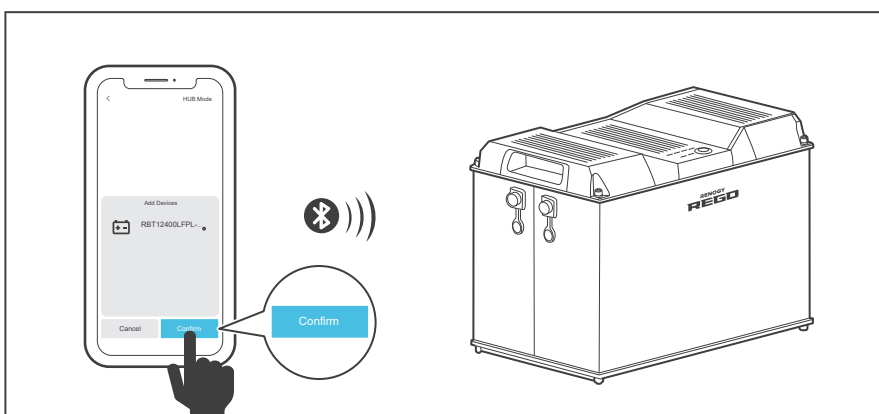

2. Tap “Confirm” on the pop-up menu to add the battery to the device list. Monitor the battery on the device page.

NOTE

- Please keep the phone or tablet within 10 feet (3 m) of the battery.

Communication

Long-Range Monitoring

If long-range communication and programming are required, connect the battery to Renogy ONE through Bluetooth or hard wire, and Renogy ONE to the DC Home app through WiFi.

Required Tool and Accessories

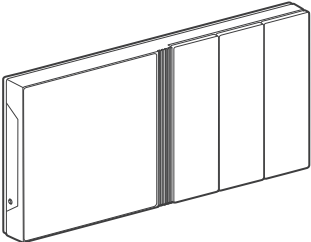
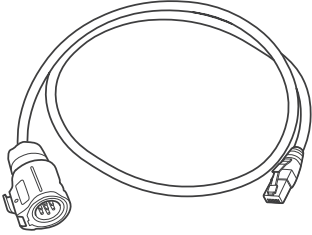
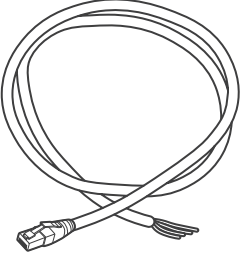
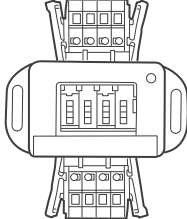
Renogy ONE	LP16 Plug (7-Pin) to RJ45 Communication Adapter Cable
	
RJ45 Plug to Bare Wires Drop Cable	Common Drop Tap
	

NOTE

- Please make sure Renogy ONE is powered on before the connection.

INFO

- Please read the user manual of Renogy ONE at renogy.com before the connection.

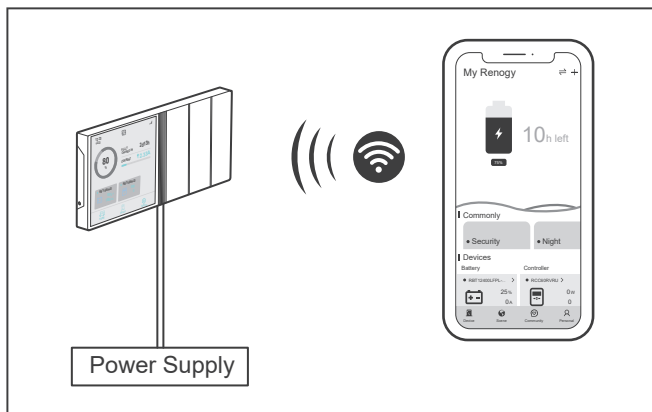

1. Pair Renogy ONE (sold separately) with the DC Home app through WiFi. If the inter-device communication is not established, refer to [step 2](#). If the inter-device communication is established with the backbone topology, refer to [step 3](#) to [step 4](#). If the inter-device communication is established with the daisy chain topology, refer to [step 5](#) to [step 6](#).

Communication

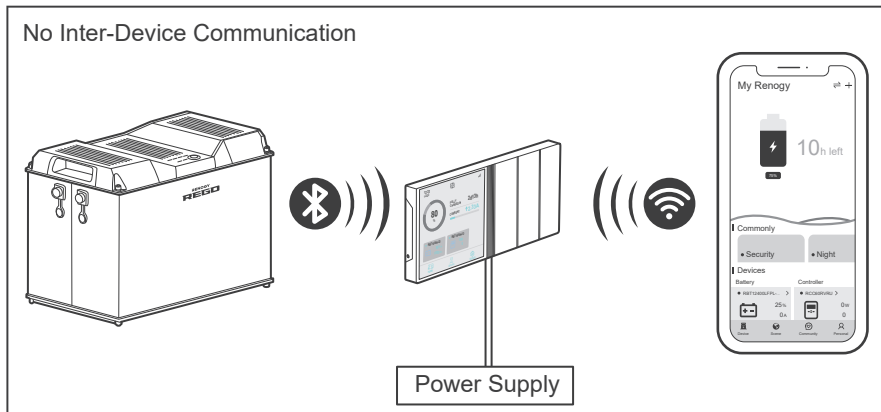

2. If the inter-device communication is not established, connect the battery to Renogy ONE through Bluetooth. Monitor the battery on Renogy ONE or the DC Home app.

i NOTE

- Please keep Renogy ONE within 10 feet (3 m) of the battery.

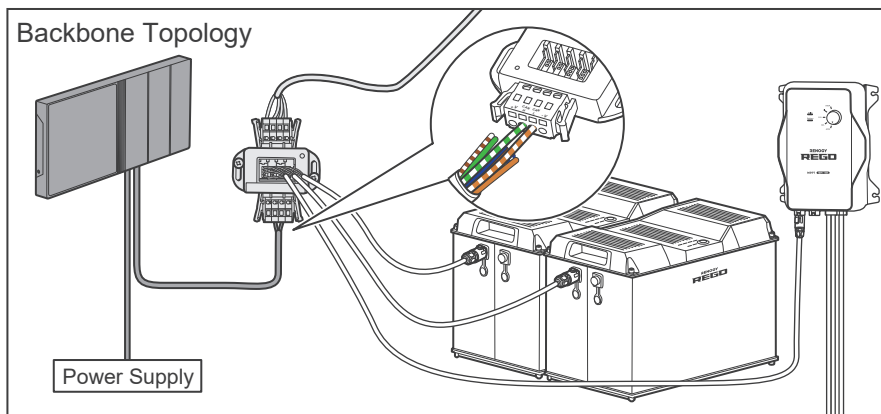

3. If the inter-device communication is established with the backbone topology, replace the terminated drop tap at either end of the RV-C bus with the Common Drop Tap (not included). Secure the bare wires of the Drop Cable (not included) onto the terminal block plug of the Common Drop Tap following the terminal block plug pinout. Plug the Drop Cable to the RJ45 port of Renogy ONE.

i NOTE

- Different terminal block plugs are used on different Common Drop Taps and follow different pinouts. Please connect the Drop Cable to the terminal block plug of the Common Drop Tap following the correct pinout. If unsure about the terminal block plug pinout, please check with the RV manufacturer. This User Manual takes the pinout of the MCS MIDI Classic terminal block plug (4-Pin) as an example.
- Please refer to the [Backbone Topology](#) section for more instructions.

Communication

Inter-Device Communication

Monitoring Device Communication

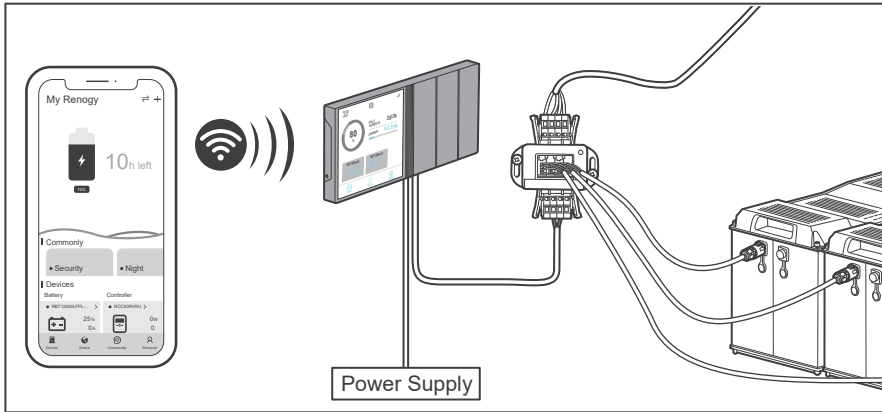

4. Monitor and program the complete system on Renogy ONE or the DC Home app.

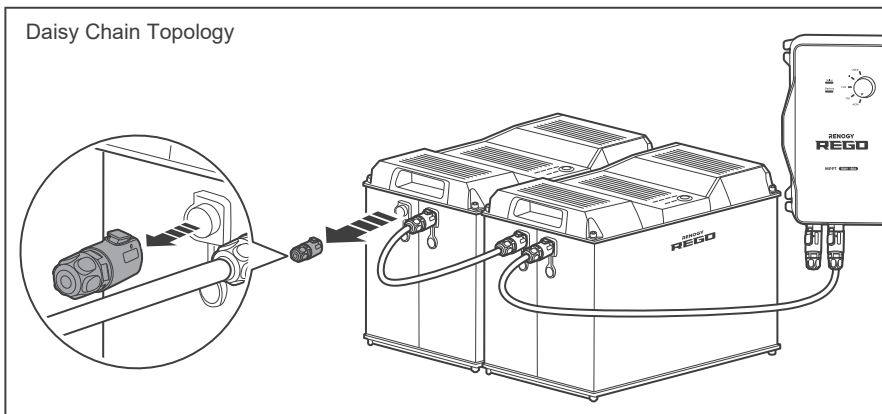

5. If the inter-device communication is established with the daisy chain topology, remove the Terminator Plug from the REGO device at either end of the daisy chain.

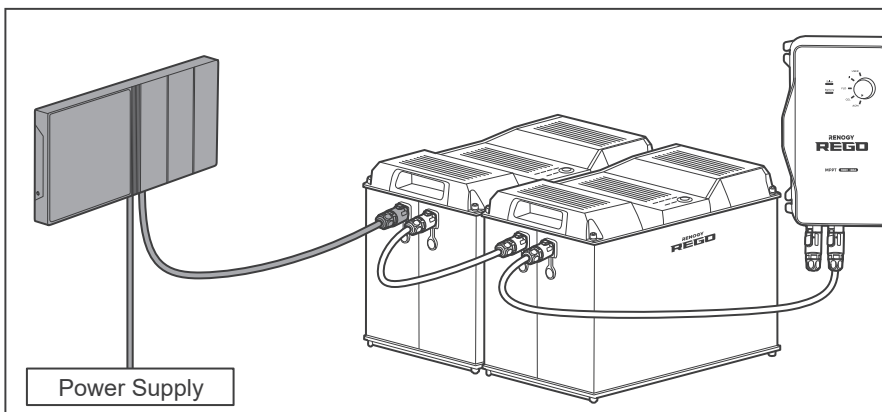

6. Connect Renogy ONE to the free CAN Communication Port on the REGO device with the Communication Adapter Cable (sold separately). Monitor and program the complete system on Renogy ONE or the DC Home app.

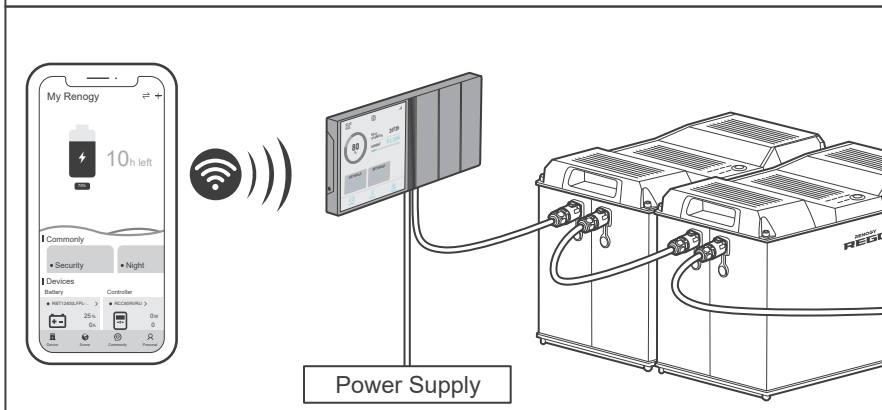

Commission

Indicator Pattern

Turning On

Checking Battery Level

Checking Battery Status

Checking Heater Status

Changing Heater Settings

Charging

Discharging

Turning Off

Indicator Pattern

Indicator Pattern	1 Second	1 Second
Solid	[Solid Blue Bar]	[Solid Blue Bar]
Slow Flash	[Blue Bar] [White Bar]	[Blue Bar] [White Bar]
Fast Flash	[Blue Bar] [White Bar] [Blue Bar] [White Bar]	[Blue Bar] [White Bar] [Blue Bar] [White Bar]
Double Flash	[Blue Bar] [White Bar] [Blue Bar] [White Bar]	[Blue Bar] [White Bar] [Blue Bar] [White Bar]
Strobe	[Blue Bar] [White Bar] [Blue Bar] [White Bar] [Blue Bar] [White Bar]	[Blue Bar] [White Bar] [Blue Bar] [White Bar] [Blue Bar] [White Bar]

Turning On

The battery is off when it leaves the factory. Please turn the battery on after connecting it to the system for the first time.

⚠ CAUTION

- DO NOT turn the battery on until completing and securing the power connection. Connecting a turned on battery to the system can trigger the short circuit or overcurrent protection of the battery.

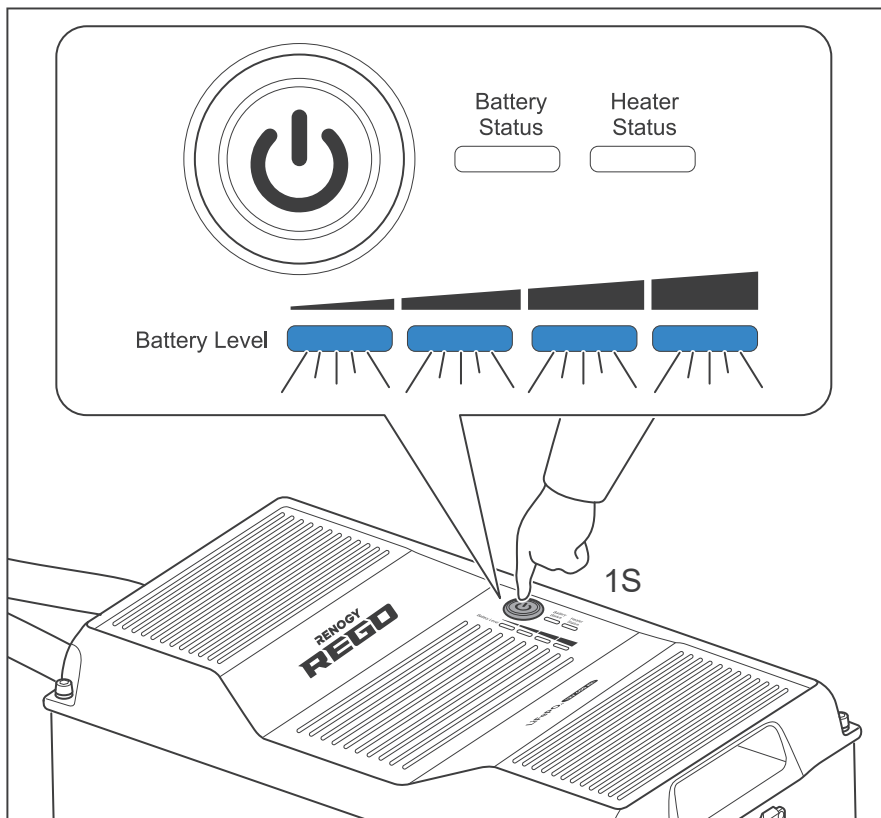

1. Long press the Power Button for 1 second or charge the battery to turn the battery on. The Battery Level Indicators fast flash blue simultaneously to indicate that the battery is turning on.

Commission

Indicator
Pattern

Turning
On

Checking
Battery Level

Checking
Battery Status

Checking
Heater Status

Changing
Heater Settings

Charging

Discharging

Turning
Off

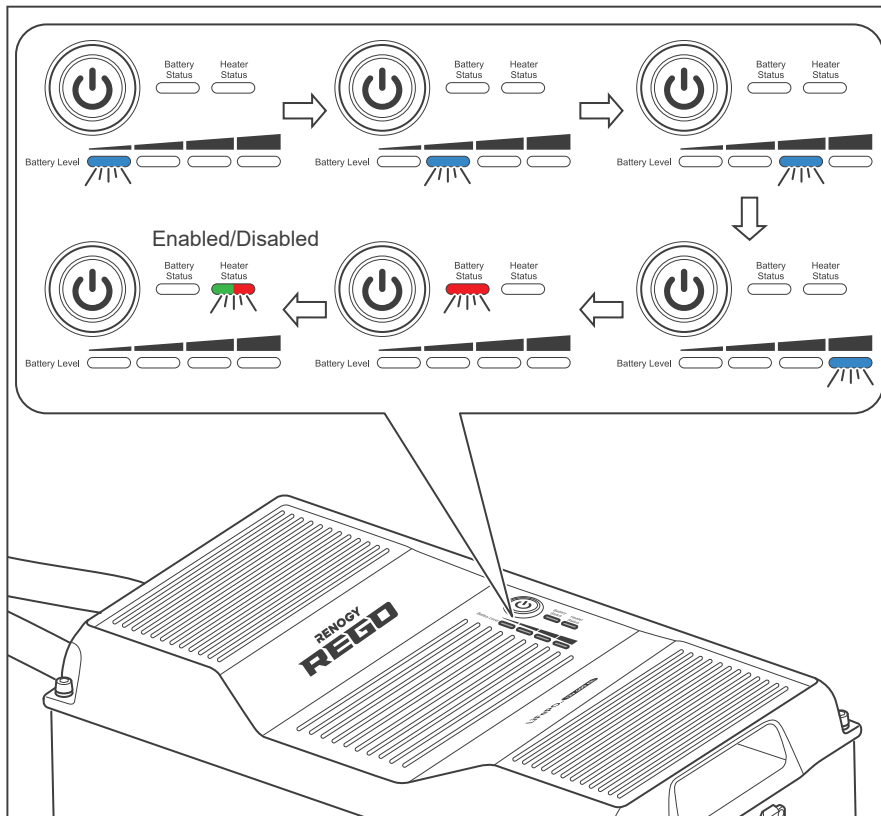

2. The Battery Level Indicators, Battery Status Indicator, and Heater Status Indicator flash in sequence once to indicate that the battery has been turned on. The color of the flashing Heater Status Indicator indicates the current heater setting.

i NOTE

- Please refer to the [Changing Heater Setting](#) section for more information about the heater settings.

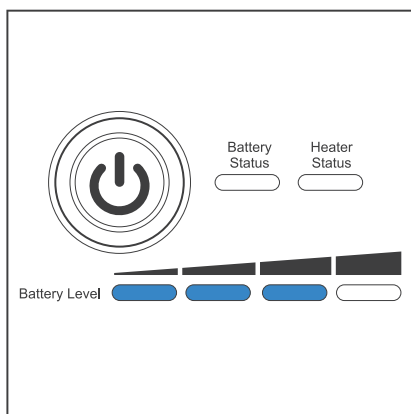

3. The Battery Level Indicators light up blue to indicate the current battery level.

! CAUTION

- If the battery is unable to be turned on, please refer to the [Troubleshooting](#) section for troubleshooting instructions.

i NOTE

- To turn on batteries connected in parallel simultaneously, please long press the Power Button on any battery for 1 second or charge the battery bank.

Commission

Indicator
Pattern

Turning
On

Checking
Battery Level

Checking
Battery Status

Checking
Heater Status

Changing
Heater Settings

Charging

Discharging

Turning
Off

Checking Battery Level

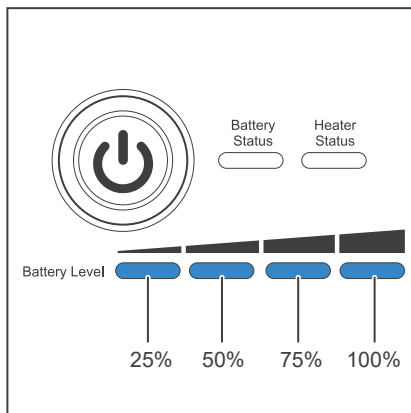

1. The four Battery Level Indicators respectively indicate 25%, 50%, 75%, and 100% battery level.

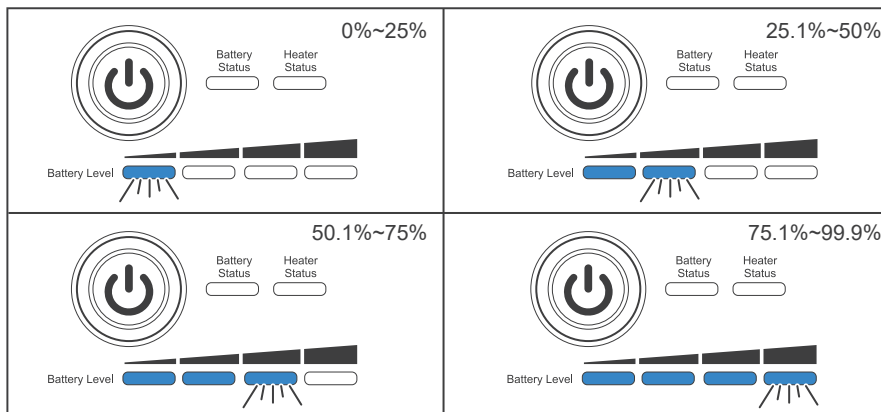

2. As the battery charges, the Battery Level Indicators light up blue one by one, and the rightmost Battery Level Indicator fast flashes blue to indicate the current battery level.

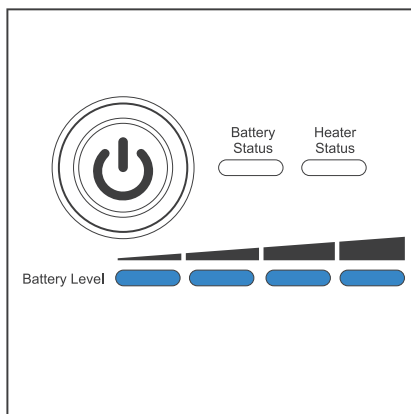

3. Once the battery is fully charged, all the Battery Level Indicators light up blue and remain solid.

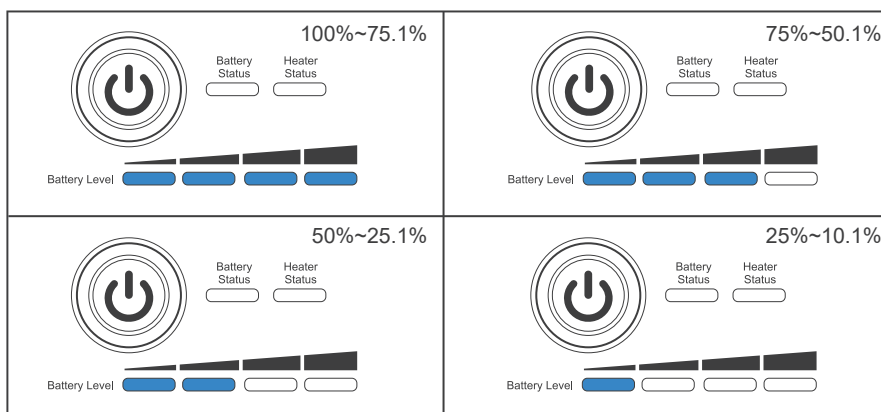

4. As the battery discharges, the Battery Level Indicators go out one by one.

Commission

Indicator
Pattern

Turning
On

Checking
Battery Level

Checking
Battery Status

Checking
Heater Status

Changing
Heater Settings

Charging

Discharging

Turning
Off

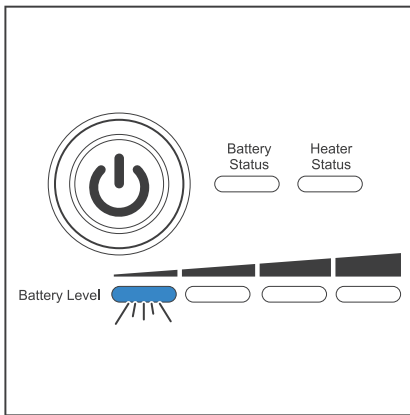

5. The last Battery Level Indicator slow flashes blue when the battery level drops below 10%.

i NOTE

- The Battery Level Indicators go out when the battery is in the heater setting mode or permanent failure mode. Please refer to the [Changing Heater Setting](#) and [Checking Battery Status](#) sections for more information.

Checking Battery Status

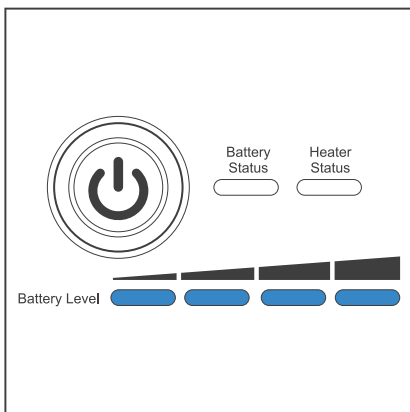

1. The Battery Status Indicator remains off when the battery is operating properly.

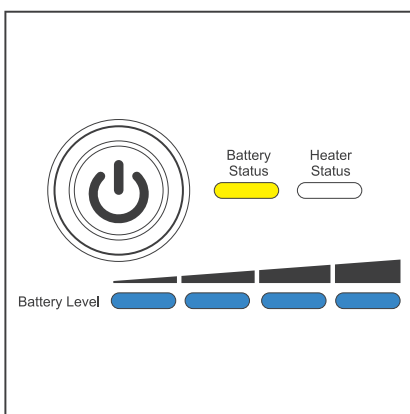

2. The Battery Status Indicator lights up/ flashes yellow when the battery is in the warning mode.

Commission

Indicator
Pattern

Turning
On

Checking
Battery Level

Checking
Battery Status

Checking
Heater Status

Changing
Heater Settings

Charging

Discharging

Turning
Off

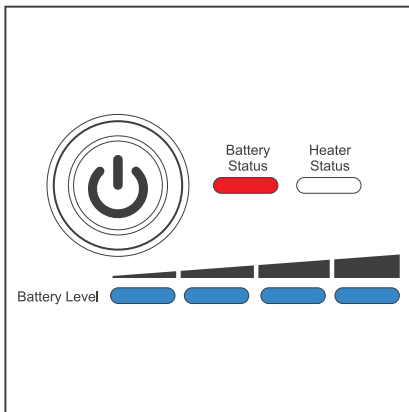

3. The Battery Status Indicator lights up/flashes red when the battery is in the protection mode.

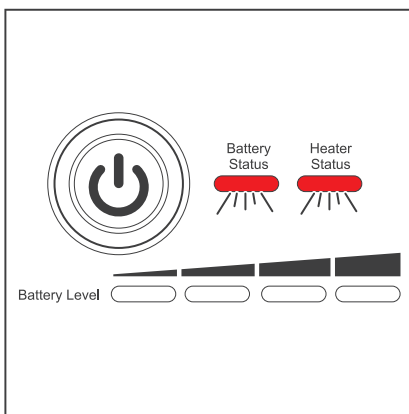

4. The Battery Status Indicator and Heater Status Indicator flash red simultaneously when the battery is in the permanent failure mode.

i NOTE

- Please refer to the [Troubleshooting](#) section for the lighting/flashing pattern of the Battery Status Indicator and Heater Status Indicator and troubleshooting instructions under different warnings, protections, and permanent failures.
- The warnings do not affect the normal operation of the battery, but it is recommended to pay closer attention to the battery to prevent triggering the protections and/or permanent failures.

Checking Heater Status

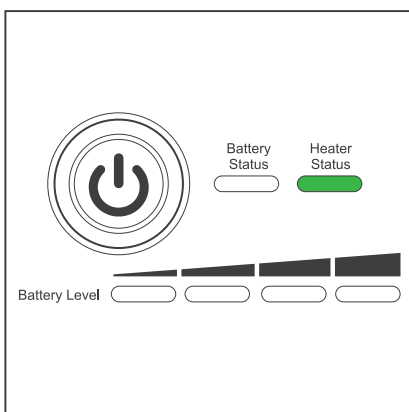

1. When the battery temperature drops below 41°F (5°C), and the charge current is stable and greater than 15A, the heater starts operating automatically, and the Heater Status Indicator lights up green.

Commission

Indicator
Pattern

Turning
On

Checking
Battery Level

Checking
Battery Status

Checking
Heater Status

Changing
Heater Settings

Charging

Discharging

Turning
Off

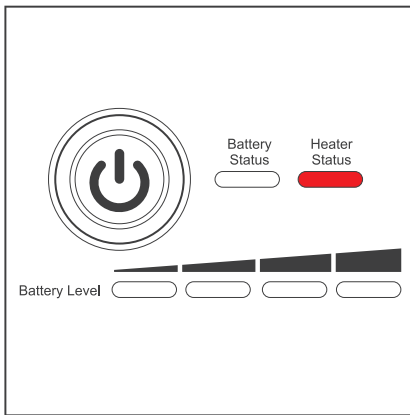

2. When the battery temperature drops below 41°F (5°C), but the charge current is unstable or less than 15A, or the heater malfunctions, the heater is unable to operate properly, and the Heater Status Indicator lights up red.

i NOTE

- Please refer to the [Troubleshooting](#) section for troubleshooting instructions.

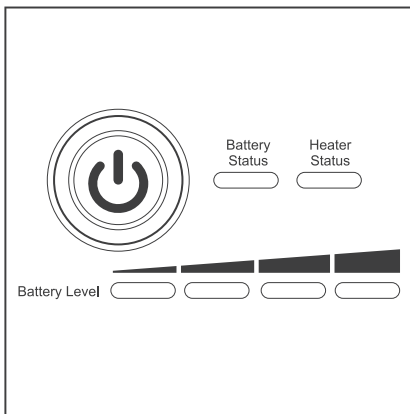

3. When the battery temperature rises above 50°F (10°C), or the charge current ceases, the heater stops operating automatically and the Heater Status Indicator goes out.

i NOTE

- The heater does not operate if the battery temperature drops below -4°F (-20°C).
- For batteries connected in parallel, each battery requires a stable charge current greater than 15A for the proper operation of the heater.

Changing Heater Settings

The battery leaves the factory with the heater enabled. The heater can be enabled or disabled with the Power Button.

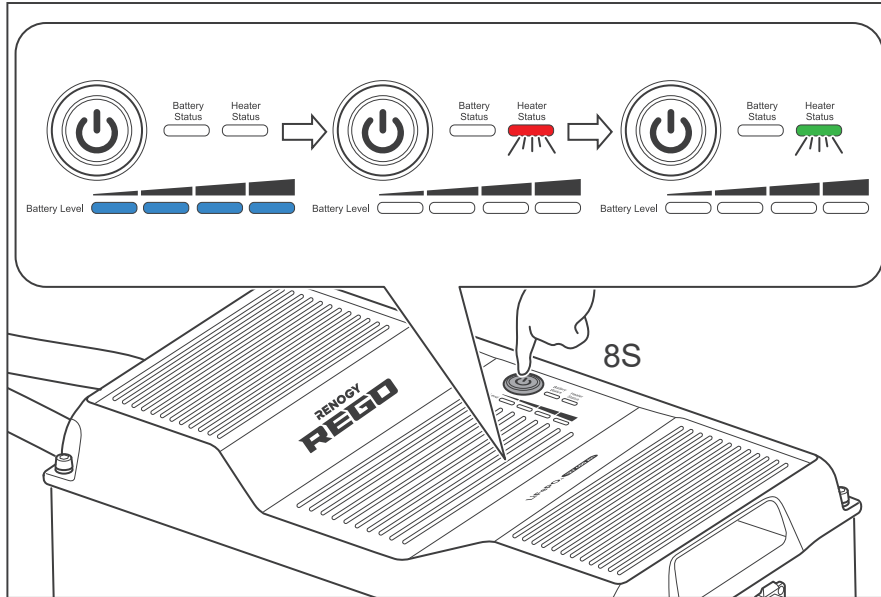

1. Long press the Power Button for 8 seconds to enter the heater setting mode. The Heater Status Indicator flashes red and green once.

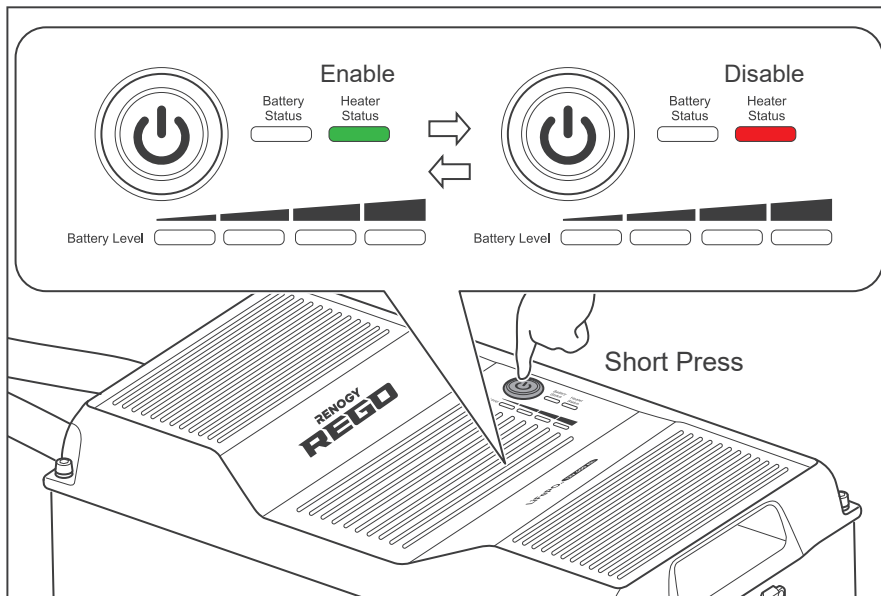

2. Short press the Power Button to enable or disable the heater. The Heater Status Indicator turns green to indicate that the heater is enabled or turns red to indicate that the heater is disabled.

Commission

Indicator
Pattern

Turning
On

Checking
Battery Level

Checking
Battery Status

Checking
Heater Status

Changing
Heater Settings

Charging

Discharging

Turning
Off

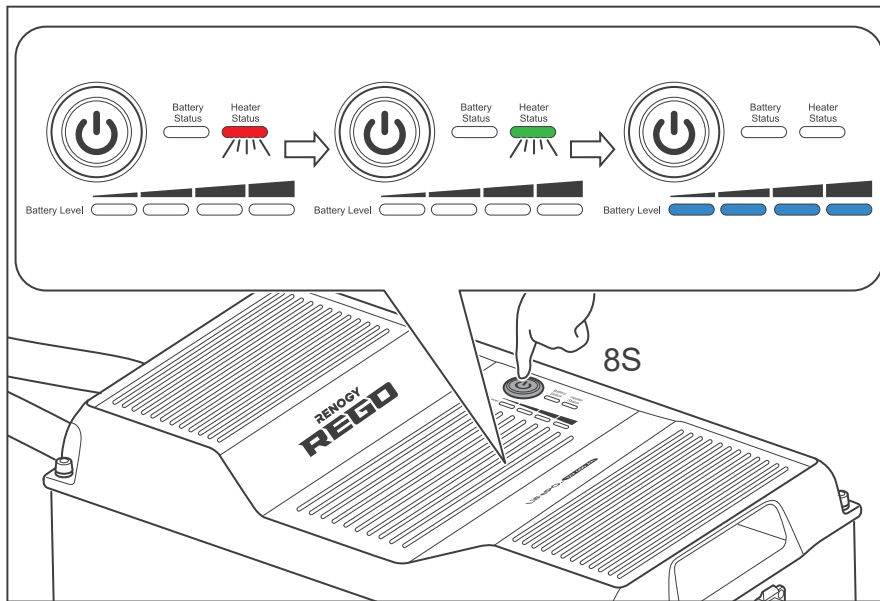

3. Long press the Power Button for 8 seconds to exit the heater setting mode and save the current setting. The Heater Status Indicator flashes red and green once.

i NOTE

- The battery automatically exits the heater setting mode and saves the current setting 10 minutes after entering the heater setting mode if it is not done manually.
- To enable or disable the heaters of batteries connected in parallel simultaneously, please establish the inter-battery communication connection and enable or disable the heater of any battery with the Power Button. If the inter-battery communication connection is not established, please enable or disable the heater of each battery individually. The heater setting **MUST** be uniform across the batteries.
- The heater is unable to operate properly at low temperatures with PWM charge controllers or low current chargers. It is recommended to disable the heater to prevent it from turning on and off repeatedly and draining the battery.

Charging

During the standard charging process, the battery is first charged at a constant current of 80A until the battery voltage reaches 14.4V. Then, the battery is charged at a constant voltage of 14.4V while tapering the charge current. The standard charging process is considered complete when the charge current is less than 20A for 10 seconds. However, leaving the battery on float can help balance the cells and does not damage the battery. The standard charging process normally takes 5.5 hours.

! WARNING

- **DO NOT** charge the battery at high temperatures above 131°F (55°C) or low temperatures above -4°F (-20°C). If the heater is disabled or unable to operate properly, charging the battery at low temperatures below 32°F (0°C) is **NOT** recommended.



CAUTION

- DO NOT overcharge the battery.
- DO NOT exceed the maximum continuous charge current of the battery.
- Please charge the battery with the chargers (not included) that are compatible with the lithium iron phosphate battery and the charge voltage set at 14.4V.
- DO NOT charge the battery immediately after a long heavy run.
- Please charge the battery immediately when the battery level drops below 10% to prevent overdischarge.



NOTE

- Please fully charge the battery prior to first use.

Discharging



WARNING

- DO NOT discharge the battery at high temperatures above 140°F (60°C) or low temperatures above -4°F (-20°C).



CAUTION

- DO NOT overdischarge the battery.
- DO NOT exceed the maximum continuous discharge current of the battery.
- DO NOT connect high power loads to the battery when it is running low.

During the standard discharging process, the battery is first discharged at a constant current of 80A until the lowest cell voltage reaches 2.5V. Then, the battery enters protection mode and cuts off all the loads to prevent the battery from overdischarge.



NOTE

- Partial discharges reduce battery stress and prolong battery cycle life. It is recommended to keep the depth of discharge below 80%.
- It is recommended to use the battery with loads featuring low voltage disconnect.

Turning Off

Prior to long periods of storage, please disconnect the battery from the system and turn it off. With the low self-discharge rate when turned off, the battery can hold the charge for a long period of time.

Commission

Indicator
Pattern

Turning
On

Checking
Battery Level

Checking
Battery Status

Checking
Heater Status

Changing
Heater Settings

Charging

Discharging

Turning
Off

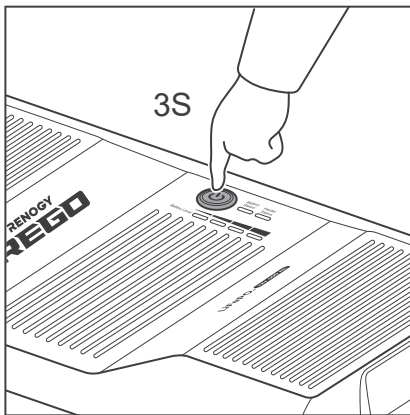

1. Long press the Power Button for 3 seconds.

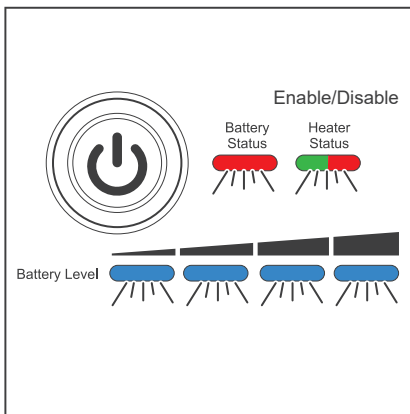

2. The Battery Level Indicators, Battery Status Indicator, and Heater Status Indicator fast flash simultaneously to indicate that the battery is turning off. The color of the flashing Heater Status Indicator indicates the current heater setting.

i NOTE

- Please refer to the [Changing Heater Setting](#) section for more information about the heater settings.

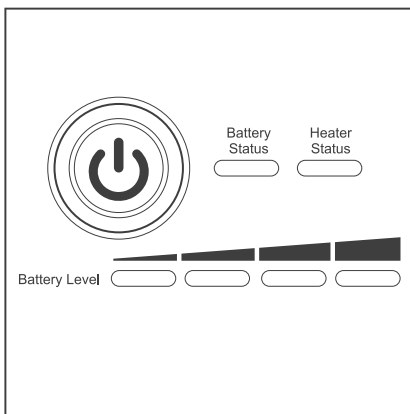

3. All the indicators go out to indicate that the battery has been turned off.

i NOTE

- The battery is unable to be turned off if the Battery Level Indicators, Battery Status Indicator, and Heater Status Indicator keep fast flashing. Please check if the battery has been disconnected from the system.
- To turn off batteries connected in parallel simultaneously, please establish the communication connection and long press the Power Button on any battery for 3 seconds. If the communication connection is not established, please disconnect batteries connected in parallel and turn off each battery individually.

Inspection

Please perform regular inspections following the steps below.

- Examine the external appearance of the battery. The housing and connector contacts of the battery shall be clean, dry, and free of corrosion.
- Check the battery cables and connections. Replace any damaged cables and tighten any loose connections.



NOTE

- In some applications, corrosion can form around the contacts internal to the Anderson Connector. The corrosion can cause loosening of spring retention force and increase of mated contact resistance, leading to premature failure of the connection. Please apply dielectric grease onto each connector contact at regular intervals. Dielectric grease can repel moisture and protect the connector contact against corrosion.

Cleaning

Please clean battery at regular intervals following the steps below.

- Disconnect the battery from the system.
- Turn the battery off with the Power Button.
- Clear the leaves and debris from the battery.
- Clean the battery with a soft, lint-free cloth. The cloth can be dampened with water or mild soap and water if the battery is extremely dirty.
- Dry the battery with a soft, lint-free cloth.
- Keep the area around the battery clean.
- Turn the battery back on with the Power Button.
- Reconnect the battery to the system.

Storage

Please follow the tips below to ensure that the battery emerges from storage in a good condition.

- Charge the battery to 30%-50%.
- Disconnect the battery from the system.
- Turn the battery off with the Power Button.
- Store the battery in a well-ventilated, dry, clean area with temperatures between -4°F (-20°C) and 113°F (45°C).
- Handle the battery carefully to avoid sharp impacts or extreme pressure on the battery housing.
- Charge the battery at least once every 3 months to prevent it from overdischarge.
- Fully charge the battery when it is taken out of storage.

Maintenance

Inspection

Cleaning

Storage



CAUTION

- DO NOT expose the battery to extreme temperatures above 140°F (60°C).
- DO NOT expose the battery to heat sources.
- DO NOT expose the battery to direct sunlight, moisture, or precipitation.

Battery Management System

Warning/Protection/Permanent Failure

Charge Current Request

Cell Voltage Balancing

Warning/Protection/Permanent Failure

Battery Status	Trigger								Release		Comment
	Threshold	Sampling Time	Delay Time	Charge MOSFET	Discharge MOSFET	Communication Power Supply	Bluetooth Power Supply	BMS Power Supply	Threshold	Sampling Time	
Cell Overvoltage Warning	Highest Cell Voltage > 3.6V	3 Seconds	0 Second	Connect	Connect	On	On	On	Highest Cell Voltage < 3.45V/ Discharge Current ≥ 3A	1 Second	
Cell Overvoltage Protection	Highest Cell Voltage > 3.7V	5 Seconds	3 Seconds	Disconnect	Connect	On	On	On	Highest Cell Voltage < 3.45V/ Discharge Current ≥ 3A	1 Second	
Cell Overvoltage Permanent Failure	Highest Cell Voltage > 4.0V	10 Seconds	3 Seconds	Disconnect	Disconnect	Off (Delay 5 Minutes)	Off (Delay 5 Minutes)	Off (Delay 5 Minutes)	Unrecoverable	/	
Cell Undervoltage Warning	Lowest Cell Voltage < 3.0V	3 Seconds	0 Second	Connect	Connect	On	On	On	Lowest Cell Voltage > 3.1V/ Charge Current ≥ 1A	1 Second	
Cell Undervoltage Protection	Lowest Cell Voltage < 2.5V	5 Seconds	3 Seconds	Connect	Disconnect	Off (Delay 5 Minutes)	Off (Delay 5 Minutes)	Off (Delay 5 Minutes)	Lowest Cell Voltage > 3.1V/ Charge Current ≥ 1A for 4 Minutes	1 Second	
Cell Undervoltage Permanent Failure	Lowest Cell Voltage < 2.0V	10 Seconds	3 Seconds	Disconnect	Disconnect	Off (Delay 5 Minutes)	Off (Delay 5 Minutes)	Off (Delay 5 Minutes)	Unrecoverable	/	
Battery Overvoltage Warning	Battery Voltage > 14.4V	3 Seconds	0 Second	Connect	Connect	On	On	On	Battery Voltage < 13.8V/ Discharge Current ≥ 3A	1 Second	
Battery Overvoltage Protection	Battery Voltage > 14.8V	5 Seconds	3 Seconds	Disconnect	Connect	On	On	On	Battery Voltage < 13.8V/ Discharge Current ≥ 3A	1 Second	
Battery Undervoltage Warning	Battery Voltage < 12V	3 Seconds	0 Second	Connect	Connect	On	On	On	Battery Voltage > 12.4V/ Charge Current ≥ 1A	1 Second	
Battery Undervoltage Protection	Battery Voltage < 10V	5 Seconds	3 Seconds	Connect	Disconnect	Off (Delay 5 Minutes)	Off (Delay 5 Minutes)	Off (Delay 5 Minutes)	Battery Voltage > 12.4V/ Charge Current ≥ 1A for 4 Minutes	1 Second	
Cell Charge High Temperature Warning	Highest Cell Temperature > 50°C (122°F)	3 Seconds	0 Second	Connect	Connect	On	On	On	Highest Cell Temperature < 45°C (113°F)	1 Second	
Cell Charge High Temperature Protection	Highest Cell Temperature > 55°C (131°F)	5 Seconds	3 Seconds	Disconnect	Connect	On	On	On	Highest Cell Temperature < 50°C (122°F)	1 Second	
Cell Discharge/Idle High Temperature Warning	Highest Cell Temperature > 55°C (131°F)	3 Seconds	0 Second	Connect	Connect	On	On	On	Highest Cell Temperature < 50°C (122°F)	1 Second	
Cell Discharge/Idle High Temperature Protection	Highest Cell Temperature > 60°C (140°F)	5 Seconds	3 Seconds	Connect	Disconnect	On	On	On	Highest Cell Temperature < 55°C (131°F)	1 Second	
Cell High Temperature Permanent Failure	Highest Cell Temperature > 70°C (158°F)	10 Seconds	3 Seconds	Disconnect	Disconnect	Off (Delay 5 Minutes)	Off (Delay 5 Minutes)	Off (Delay 5 Minutes)	Unrecoverable	/	
Cell Charge Low Temperature Warning	Lowest Cell Temperature < 3°C (37.4°F)	3 Seconds	0 Second	Connect	Connect	On	On	On	Lowest Cell Temperature > 6°C (42.8°F)	1 Second	
Cell Charge Low Temperature Protection	Charge Current < 23.6A	Lowest Cell Temperature < -20°C (-4°F)	5 Seconds	3 Seconds	Disconnect	Connect	On	On	On	Lowest Cell Temperature > -17°C (1.4°F)	1 Second
	Charge Current ≥ 23.6A										
Cell Discharge/Idle Low Temperature Warning	Lowest Cell Temperature < -17°C (1.4°F)	3 Seconds	0 Second	Connect	Connect	On	On	On	Lowest Cell Temperature > -14°C (6.8°F)	1 Second	
Cell Discharge/Idle Low Temperature Protection	Lowest Cell Temperature < -20°C (-4°F)	5 Seconds	3 Seconds	Connect	Disconnect	On	On	On	Lowest Cell Temperature > -17°C (1.4°F)	1 Second	
Environment High Temperature Warning	Battery Interior Environment Temperature > 75°C (167°F)	3 Seconds	0 Second	Connect	Connect	On	On	On	Battery Interior Environment Temperature < 65°C (149°F)	1 Second	
Environment High Temperature Protection	Battery Interior Environment Temperature > 80°C (176°F)	5 Seconds	3 Seconds	Disconnect	Disconnect	Off (Delay 1 Minute)	Off (Delay 1 Minute)	Off (Delay 1 Minute)	Battery Interior Environment Temperature < 65°C (149°F)	1 Second	
Environment Low Temperature Warning	Battery Interior Environment Temperature < -30°C (-22°F)	3 Seconds	0 Second	Connect	Connect	On	On	On	Battery Interior Environment Temperature > -25°C (-13°F)	1 Second	
Environment Low Temperature Protection	Battery Interior Environment Temperature < -35°C (-31°F)	5 Seconds	3 Seconds	Disconnect	Disconnect	Off (Delay 1 Minute)	Off (Delay 1 Minute)	Off (Delay 1 Minute)	Battery Interior Environment Temperature > -25°C (-13°F)	1 Second	
Cell Imbalance Warning	Cell Voltage Difference > 600mV	3 Seconds	0 Second	Connect	Connect	On	On	On	Cell Voltage Difference < 200mV	1 Second	
Cell Imbalance Protection	Cell Voltage Difference > 1000mV	5 Seconds	3 Seconds	Disconnect	Disconnect	On	On	On	Cell Voltage Difference < 200mV	1 Second	



Battery Management System

Warning/Protection/Permanent Failure

Charge Current Request

Cell Voltage Balancing

Battery Status	Trigger									Release		Comment
	Threshold		Sampling Time	Delay Time	Charge MOSFET	Discharge MOSFET	Communication Power Supply	Bluetooth Power Supply	BMS Power Supply	Threshold	Sampling Time	
Charge Overcurrent Warning	Cell Temperature $\leq 15^{\circ}\text{C}$ (59°F)	Charge Current $> 220\text{A}$	3 Seconds	0 Second	Connect	Connect	On	On	On	Charge Current $< 200\text{A}$	1 Second	
	15°C (59°F) $<$ Cell Temperature $< 50^{\circ}\text{C}$ (131°F)	Charge Current $> 330\text{A}$								Charge Current $< 300\text{A}$		
	Cell Temperature $\geq 55^{\circ}\text{C}$ (131°F)	Charge Current $> 220\text{A}$								Charge Current $< 200\text{A}$		
Charge Overcurrent Primary Protection	Cell Temperature $\leq 15^{\circ}\text{C}$ (59°F)	Charge Current $> 230\text{A}$	15 Seconds	3 Seconds	Disconnect	Connect	On	On	On	Charge Current $< 200\text{A}/$ Discharge Current $\geq 3\text{A}$	1 Second	
	15°C (59°F) $<$ Cell Temperature $< 50^{\circ}\text{C}$ (131°F)	Charge Current $> 345\text{A}$								Charge Current $< 300\text{A}/$ Discharge Current $\geq 3\text{A}$		
	Cell Temperature $\geq 55^{\circ}\text{C}$ (131°F)	Charge Current $> 230\text{A}$								Charge Current $< 200\text{A}/$ Discharge Current $\geq 3\text{A}$		
Charge Overcurrent Secondary Protection	Cell Temperature $\leq 15^{\circ}\text{C}$ (59°F)	Charge Current $> 236\text{A}$	5 Seconds	3 Seconds	Disconnect	Connect	On	On	On	Charge Current $< 200\text{A}/$ Discharge Current $\geq 3\text{A}$	1 Second	
	15°C (59°F) $<$ Cell Temperature $< 50^{\circ}\text{C}$ (131°F)	Charge Current $> 354\text{A}$								Charge Current $< 300\text{A}/$ Discharge Current $\geq 3\text{A}$		
	Cell Temperature $\geq 55^{\circ}\text{C}$ (131°F)	Charge Current $> 236\text{A}$								Charge Current $< 200\text{A}/$ Discharge Current $\geq 3\text{A}$		
Discharge Overcurrent Warning	Discharge Current $> 385\text{A}$		3 Seconds	0 Second	Connect	Connect	On	On	On	Discharge Current $< 350\text{A}$	1 Second	
Discharge Overcurrent Primary Protection	Discharge Current $> 402.5\text{A}$		15 Seconds	3 Seconds	Connect	Disconnect	On	On	On	Discharge Current $< 350\text{A}/$ Charge Current $\geq 1\text{A}$	1 Second	The battery automatically attempts to recover 1 minute after the protection.
Discharge Overcurrent Secondary Protection	Discharge Current $> 413\text{A}$		5 Seconds	3 Seconds	Connect	Disconnect	On	On	On	Discharge Current $< 350\text{A}/$ Charge Current $\geq 1\text{A}$	1 Second	The interval between each attempt is 1 minute. If the battery fails 3 consecutive attempts, the protection can only be released with a charge current greater than 1A.
Discharge Overcurrent Hardware Protection	Discharge Current $> 700\text{A}$		100 Microseconds	0 Second	Disconnect	Disconnect	On	On	On	Discharge Current $< 350\text{A}/$ Charge Current $\geq 1\text{A}$	100 Microseconds	
Low SOH Warning	SOH $< 55\%$		3 Seconds	0 Second	Connect	Connect	On	On	On	SOH $> 56\%$	1 Second	
Low SOH Permanent Failure	SOH $< 50\%$		5 Seconds	3 Seconds	Disconnect	Disconnect	Off (Delay 5 Minutes)	Off (Delay 5 Minutes)	Off (Delay 5 Minutes)	Unrecoverable	/	
Low SOC Warning	SOC $\leq 2\%$		3 Seconds	0 Second	Connect	Connect	On	On	On	SOC $> 4\%$ / Charge Current $\geq 1\text{A}$	1 Second	
CAN Communication Error Warning	Unable to Receive CAN Messages for 1 Minute		1 Minute	0 Second	Connect	Connect	On	On	On	Receives CAN Messages	0 Second	
Short Circuit Protection	Short Circuit Current $> 800\text{A}$		1 Millisecond	0 Second	Connect	Disconnect	On	On	On	Remove Short Circuit/ Charge Current $\geq 1\text{A}$	1 Second	The battery automatically attempts to recover 1 minute after the protection. The interval between each attempt is 1 minute. If the battery fails 3 consecutive attempts, the protection can only be released with a charge current greater than 1A.
Reverse Polarity Protection	Connection Polarity Reverse		0 Second	0 Second	Disconnect	Disconnect	Off (Delay 5 Minutes)	Off (Delay 5 Minutes)	Off (Delay 5 Minutes)	Connection Polarity Correct	0 Second	
Pre-Charge Failure Protection	Voltage Difference Across Pre-Charge MOSFETE $> 4\text{V}$		0 Second	0 Second	Disconnect	Disconnect	On	On	On	Voltage Difference Across Pre-Charge MOSFETE $< 1\text{V}$	0 Second	The battery automatically attempts to recover 1 minute after the protection. The interval between each attempt is 1 minute. If the battery fails 3 consecutive attempts, the protection can only be released with a restart.
Battery Source Address Conflict Warning	Source Address Conflict between Devices		0 Second	0 Second	Connect	Connect	On	On	On	Finds Unclaimed Source Address	0 Second	
AFE Communication Error Protection	Unable to Receive AFE Messages for 10 Seconds		10 Seconds	3 Seconds	Disconnect	Disconnect	Off (Delay 5 Minutes)	Off (Delay 5 Minutes)	Off (Delay 5 Minutes)	Receives AFE Messages	0 Second	
Memory Communication Error Warning	Communication Between EEPROM and Flash Memory Fails 3 Times		0 Second	0 Second	Connect	Connect	On	On	On	Communication Between EEPROM and Flash Memory Succeeds	0 Second	



Battery Management System

Warning/Protection/Permanent Failure

Charge Current Request

Cell Voltage Balancing

Battery Status	Trigger								Release		Comment
	Threshold	Sampling Time	Delay Time	Charge MOSFET	Discharge MOSFET	Communication Power Supply	Bluetooth Power Supply	BMS Power Supply	Threshold	Sampling Time	
MOSFET High Temperature Warning	MOSFET Temperature > 85°C (185°F)	3 Seconds	0 Second	Connect	Connect	On	On	On	MOSFET Temperature < 80°C (176°F)	1 Second	
MOSFET High Temperature Protection	MOSFET Temperature > 105°C (221°F)	5 Seconds	3 Seconds	Disconnect	Disconnect	Off (Delay 5 Minutes)	Off (Delay 5 Minutes)	Off (Delay 5 Minutes)	MOSFET Temperature < 90°C (194°F)	1 Second	
Balancing Circuit High Temperature Warning	Balancing Circuit > 85°C (185°F)	3 Seconds	0 Second	Connect	Connect	On	On	On	Balancing Circuit < 80°C (176°F)	1 Second	
Balancing Circuit High Temperature Protection	Balancing Circuit > 105°C (221°F)	5 Seconds	3 Seconds	Disconnect	Disconnect	Off (Delay 5 Minutes)	Off (Delay 5 Minutes)	Off (Delay 5 Minutes)	Balancing Circuit < 85°C (185°F)	1 Second	
Temperature Sampling Error Protection	Unable to Detect Temperature Sampling Signal	3 Seconds	3 Seconds	Disconnect	Disconnect	Off (Delay 5 Minutes)	Off (Delay 5 Minutes)	Off (Delay 5 Minutes)	Detects Temperature Sampling Signal	0 Second	
Charge MOSFET Permanent Failure	Charge Current ≥ 3A When Disconnecting Charge MOSFET is Required/ Unable To Connect Charge MOSFET When Required	0 Second	3 Seconds	Disconnect	Disconnect	Off (Delay 1 Minute)	Off (Delay 1 Minute)	Off (Delay 1 Minute)	Unrecoverable	/	
Discharge MOSFET Permanent Failure	Discharge Current ≥ 3A When Disconnecting Discharge MOSFET is Required/ Unable To Connect Discharge MOSFET When Required	0 Second	3 Seconds	Disconnect	Disconnect	Off (Delay 1 Minute)	Off (Delay 1 Minute)	Off (Delay 1 Minute)	Unrecoverable	/	
Voltage Sampling Error Protection	Difference Between Voltages Sampled by MCU and AFE > 1V	3 Seconds	3 Seconds	Disconnect	Disconnect	Off (Delay 5 Minutes)	Off (Delay 5 Minutes)	Off (Delay 5 Minutes)	Difference Between Voltages Sampled by MCU and AFE < 0.5V	1 Second	
Communication Power Supply Malfunction Warning	Communication Power Supply Voltage ≤ 10V/ Communication Power Supply Voltage ≥ 14.8V	5 Seconds	0 Second	Connect	Connect	Off (Delay 5 Seconds)	On	On	10V < Communication Power Supply Voltage < 14.8V	1 Second	
RTC Error Warning	Unable to Receive RTC Messages for 10 Seconds	10 Seconds	0 Second	Connect	Connect	On	On	On	Receives RTC Messages	0 Second	
Heater High Temperature Warning	Heater Temperature > 75°C (167°F)	3 Seconds	0 Second	Connect	Connect	On	On	On	Heater Temperature < 50°C (122°F)	1 Second	
Heater High Temperature Protection	Heater Temperature > 85°C (185°F)	5 Seconds	3 Seconds	Disconnect	Disconnect	On	On	On	Heater Temperature < 70°C (158°F)	1 Second	
Heater High Temperature Hardware Protection	Heater Temperature > 90°C (194°F)	10 Seconds	3 Seconds	Disconnect	Disconnect	Off (Delay 1 Minute)	Off (Delay 1 Minute)	Off (Delay 1 Minute)	Heater Temperature < 65°C (149°F)	Restart	The heater fuse blows when the protection is triggered. The heater is unable to operate anymore even the protection is released.
Heater Malfunction Warning	Unable to Heat Battery Up When Heater is On	5 Seconds	0 Second	Connect	Connect	On	On	On	Heats Battery Up When Heater is On	0 Second	
Fuse Permanent Failure	Voltage Difference Across > 5V	3 Seconds	3 Seconds	Disconnect	Disconnect	Off (Delay 5 Minutes)	Off (Delay 5 Minutes)	Off (Delay 5 Minutes)	Unrecoverable	/	
AFE Overvoltage Protection	AFE Sampled Cell Voltage > 3.9V	0 Second	0 Second	Disconnect	Disconnect	On	On	On	AFE Sampled Cell Voltage < 3.9V	Restart	
AFE Undervoltage Protection	AFE Sampled Cell Voltage < 2V	0 Second	0 Second	Disconnect	Disconnect	Off (Delay 1 Minute)	Off (Delay 1 Minute)	Off (Delay 1 Minute)	AFE Sampled Cell Voltage > 2V	Restart	
BMS Power Supply Malfunction Protection	BMS Power Supply Voltage ≤ 13.2V/ BMS Power Supply Voltage ≥ 10.8V	5 Seconds	3 Seconds (BMS Power Supply Undamaged)	Disconnect	Disconnect	Off (Delay 5 Minutes)	Off (Delay 5 Minutes)	Off (Delay 5 Minutes)	10.8V < BMS Power Supply Voltage < 13.2V	5 Seconds	
AFE High Temperature Protection	AFE Sampled Cell Temperature > 65°C (149°F)	0 Second	3 Seconds	Disconnect	Disconnect	On	On	On	AFE Sampled Cell Temperature < 60°C (140°F)	1 Second	
AFE Low Temperature Protection	AFE Sampled Cell Temperature < -25°C (-13°F)	0 Second	3 Seconds	Disconnect	Disconnect	On	On	On	AFE Sampled Cell Temperature > -20°C (-4°F)	1 Second	

Battery Management System

Warning/Protection/Permanent Failure

Charge Current Request

Cell Voltage Balancing

Charge Current Request

With the communication connections established between the battery and chargers, the battery management system can automatically request appropriate charge current from the chargers based on the cell voltage and temperature to prolong battery cycle life.

Cell Temperature Highest Cell Voltage	Desired Charge Current									
	<-19°C (-2.2°F)	-19°C ~ 0°C (-2.2°F ~ 32°F)	0°C ~ 1°C (32°F ~ 33.8°F)	1°C ~ 15°C (33.8°F ~ 59°F)	15°C ~ 16°C (59°F ~ 60.8°F)	16°C ~ 49°C (60.8°F ~ 120.2°F)	49°C ~ 50°C (120.2°F ~ 122°F)	50°C ~ 53°C (122°F ~ 127.4°F)	53°C ~ 54°C (127.4°F ~ 129.2°F)	> 54°C (129.2°F)
Cell Undervoltage Permanent Failure	0A	0A	0A	0A	0A	0A	0A	0A	0A	0A
Cell Undervoltage Permanent Failure~2.5V	0A	5A	5A → 40A	40A	40A	40A	40A	40A	40A → 20A	0A
2.5V~3.5V	0A	5A	5A → 200A	200A	200A → 300A	300A	300A → 100A	100A	100A → 20A	0A
3.5V~3.54V	0A	5A	↓	↓	↓	↓	↓	↓	↓	0A
3.54V~Full	0A	5A	5A	5A	15A	15	15	15	15	0A
Full	0A	0A	0A	0A	0A	0A	0A	0A	0A	0A



NOTE

- After a full charge, the battery stops requesting charge current until the battery level drops below 95%.

Cell Voltage Balancing

The battery management system is equipped with a passive balancing circuit to balance the cell voltages. Each series connected cell is connected to a bypass resistor and a switch. During the charging process, the battery management system turns on the switch for the cell whose voltage is significantly higher than other cells and shunts the charge current through its bypass resistor until the voltage difference between cells gets small enough. To avoid excessive energy loss, the cell voltage balancing is only performed during the charging process.

Troubleshooting

Phenomenon		Possible Causes	Solutions
Battery Status Indicator	Heater Status Indicator		
Solid Yellow		Charge Overcurrent Warning	<ul style="list-style-type: none"> Reduce the charge current immediately.
		Discharge Overcurrent Warning	<ul style="list-style-type: none"> Reduce the discharge current immediately.
Slow Flash Yellow	Lights up / Flashes According to the Heater Status	Cell Overvoltage Warning	<ul style="list-style-type: none"> Ensure that the chargers are compatible with the lithium iron phosphate battery. Ensure that the battery type is set to lithium iron phosphate and the charge voltage is set to 14.4V on the chargers. Slightly reduce the charge voltage or connect voltage sensors to the chargers to compensate for the voltage drops across the charging cables if necessary. The charging can be continued if the chargers are compatible with the lithium iron phosphate battery and the battery type and charge voltage are set properly on the chargers.
		Battery Overvoltage Warning	<ul style="list-style-type: none"> Ensure that the chargers are compatible with the lithium iron phosphate battery. Ensure that the battery type is set to lithium iron phosphate and the charge voltage is set to 14.4V on the chargers. Slightly reduce the charge voltage or connect voltage sensors to the chargers to compensate for the voltage drops across the charging cables if necessary. The charging can be continued if the chargers are compatible with the lithium iron phosphate battery and the battery type and charge voltage are set properly on the chargers.
		Cell Undervoltage Warning	<ul style="list-style-type: none"> Charge the battery immediately.
		Battery Undervoltage Warning	<ul style="list-style-type: none"> Charge the battery immediately.
		Low SOC Warning	<ul style="list-style-type: none"> Charge the battery immediately.

Troubleshooting

Phenomenon		Possible Causes	Solutions
Battery Status Indicator	Heater Status Indicator		
Slow Flash Yellow	Lights up / Flashes According to the Heater Status	Cell Voltage Imbalance Warning	<ul style="list-style-type: none"> • Disconnect the battery from the system. • Leave the battery resetting for 24 hours. • Contact us for help if the warning persists
Fast Flash Yellow		CAN Communication Error Warning	<ul style="list-style-type: none"> • Ensure that the inter-device communication connections are solid. • Restart the battery if no inter-device communication connection is established.
		Battery Source Address Conflict Warning	<ul style="list-style-type: none"> • Restart the battery. • Contact us for help if the warning persists.
		Memory Communication Error Warning	<ul style="list-style-type: none"> • Restart the battery. • The memory connection might have been loose if the warning persists. Contact us for help.
		RTC Error Warning	<ul style="list-style-type: none"> • Restart the battery. • The RTC connection might have been loose if the warning persists. Contact us for help.
		Communication Power Supply Malfunction Warning	<ul style="list-style-type: none"> • Restart the battery. • The communication power supply might have been damaged if the warning persists. Contact us for help.
Strobe Yellow		Cell Charge High Temperature Warning	<ul style="list-style-type: none"> • Increase the airflow for efficient heat dissipation. • Insulate the battery from hot weather if necessary. • Reduce the charge current to avoid internal heat buildup.
		Cell Discharge/ Idle High Temperature Warning	<ul style="list-style-type: none"> • Increase the airflow for efficient heat dissipation. • Insulate the battery from hot weather if necessary. • Reduce the discharge current to avoid internal heat buildup.

Troubleshooting

Phenomenon		Possible Causes	Solutions
Battery Status Indicator	Heater Status Indicator		
Strobe Yellow	Lights up / Flashes According to the Heater Status	Cell Charge Low Temperature Warning	<ul style="list-style-type: none"> • Insulate the battery from cold weather. • Ensure that the heater is enabled and operating properly.
		Cell Discharge/ Idle Low Temperature Warning	<ul style="list-style-type: none"> • Insulate the battery from cold weather. • Warm up the battery with external heat sources.
		Environment High Temperature Warning	<ul style="list-style-type: none"> • Increase the airflow for efficient heat dissipation. • Insulate the battery from hot weather if necessary. • Reduce the charge/discharge current to avoid internal heat buildup if the battery is charging/discharging.
		Environment Low Temperature Warning	<ul style="list-style-type: none"> • Insulate the battery from cold weather. • Warm up the battery with the heater or external heat sources.
		MOSFET High Temperature Warning	<ul style="list-style-type: none"> • Increase the airflow for efficient heat dissipation. • Insulate the battery from hot weather if necessary. • Reduce the charge/discharge current to avoid internal heat buildup.
		Balancing Circuit High Temperature Warning	<ul style="list-style-type: none"> • Increase the airflow for efficient heat dissipation. • Insulate the battery from hot weather if necessary. • Reduce the charge/discharge current to avoid internal heat buildup.
		Heater High Temperature Warning	<ul style="list-style-type: none"> • Restart the battery. • The heater MOSFET might have been damaged if the warning persists. Contact us for help.

Troubleshooting

Phenomenon		Possible Causes	Solutions
Battery Status Indicator	Heater Status Indicator		
Double Flash Yellow	Lights up / Flashes According to the Heater Status	Low SOH Warning	<ul style="list-style-type: none"> Restart the battery. The battery is near the end of life if the warning persists. Replace the battery if necessary.
		Battery Voltage Imbalance Warning	<ul style="list-style-type: none"> Disassemble the battery bank. Charge the batteries individually to bring the voltages to the same level. Reconnect the batteries in parallel.
Charge Primary/ Secondary Overcurrent Protection		<ul style="list-style-type: none"> Reduce the charge current immediately. Discharge or restart the battery if the protection is not released automatically after 1 minute. 	
Discharge Primary/ Secondary Overcurrent Protection		<ul style="list-style-type: none"> Reduce the discharge current immediately. Charge or restart the battery if the protection is not released automatically after 1 minute. 	
Short Circuit Protection		<ul style="list-style-type: none"> Locate and repair the short circuits immediately. Charge or restart the battery if the protection is not released automatically after 1 minute. 	
Reverse Polarity Protection		<ul style="list-style-type: none"> Check and correct the connection polarity. 	
Pre-Charge Failure Protection		<ul style="list-style-type: none"> Reduce initial DC load. Restart the battery if the protection is not released automatically after 1 minute. 	
Solid Red			

Troubleshooting

Phenomenon		Possible Causes	Solutions
Battery Status Indicator	Heater Status Indicator		
Slow Flash Red	Lights up / Flashes According to the Heater Status	Cell Overvoltage Protection	<ul style="list-style-type: none"> • Ensure that the chargers are compatible with the lithium iron phosphate battery. • Ensure that the battery type is set to lithium iron phosphate and the charge voltage is set to 14.4V on the chargers. Slightly reduce the charge voltage or connect voltage sensors to the chargers to compensate for the voltage drops across the charging cables if necessary. • The cell overvoltage protection might be triggered near the end of the charging process due to cell voltage divergence. No risk of damage is present if the chargers are compatible with the lithium iron phosphate battery and the battery type and charge voltage are set properly on the chargers.
		Battery Overvoltage Protection	<ul style="list-style-type: none"> • Ensure that the chargers are compatible with the lithium iron phosphate battery. • Ensure that the battery type is set to lithium iron phosphate and the charge voltage is set to 14.4V on the chargers. Slightly reduce the charge voltage or connect voltage sensors to the chargers to compensate for the voltage drops across the charging cables if necessary.
		Cell Undervoltage Protection	<ul style="list-style-type: none"> • Charge the battery immediately.
		Battery Undervoltage Protection	<ul style="list-style-type: none"> • Charge the battery immediately.
		Cell Voltage Imbalance Protection	<ul style="list-style-type: none"> • Disconnect the battery from the system. • Leave the battery resting for 24 hours. • Contact us for help if the protection persists

Troubleshooting

Phenomenon		Possible Causes	Solutions
Battery Status Indicator	Heater Status Indicator		
Slow Flash Red	Lights up / Flashes According to the Heater Status	AFE Overvoltage Protection	<ul style="list-style-type: none"> Ensure that the chargers are compatible with the lithium iron phosphate battery. Ensure that the battery type is set to lithium iron phosphate and the charge voltage is set to 14.4V on the chargers. Slightly reduce the charge voltage or connect voltage sensors to the chargers to compensate for the voltage drops across the charging cables if necessary.
		AFE Undervoltage Protection	<ul style="list-style-type: none"> Charge the battery immediately.
		Voltage Sampling Error Protection	<ul style="list-style-type: none"> Restart the battery. The voltage sensor connection might have been loose if the protection persists. Contact us for help.
Fast Flash Red		AFE Communication Error Protection	<ul style="list-style-type: none"> Restart the battery. The AFE connection might have been loose if the protection persists. Contact us for help.
		BMS Power Supply Malfunction Protection	<ul style="list-style-type: none"> Restart the battery. The BMS power supply might have been damaged if the warning persists. Contact us for help.
Strobe Red		Cell Charge High Temperature Protection	<ul style="list-style-type: none"> Increase the airflow for efficient heat dissipation. Insulate the battery from hot weather if necessary.
		Cell Discharge/ Idle High Temperature Protection	<ul style="list-style-type: none"> Increase the airflow for efficient heat dissipation. Insulate the battery from hot weather if necessary.
	Cell Charge Low Temperature Protection	<ul style="list-style-type: none"> Insulate the battery from cold weather. Ensure that the heater is enabled and operating properly. 	
	Cell Discharge/ Idle Low Temperature Protection	<ul style="list-style-type: none"> Insulate the battery from cold weather. Warm up the battery with external heat sources. 	

Troubleshooting

Phenomenon		Possible Causes	Solutions
Battery Status Indicator	Heater Status Indicator		
Strobe Red	Lights up / Flashes According to the Heater Status	Environment High Temperature Protection	<ul style="list-style-type: none"> • Increase the airflow for efficient heat dissipation. • Insulate the battery from hot weather if necessary.
		Environment Low Temperature Protection	<ul style="list-style-type: none"> • Insulate the battery from cold weather. • Warm up the battery with the heater or external heat sources.
		MOSFET High Temperature Protection	<ul style="list-style-type: none"> • Increase the airflow for efficient heat dissipation. • Insulate the battery from hot weather if necessary.
		Balancing Circuit High Temperature Protection	<ul style="list-style-type: none"> • Increase the airflow for efficient heat dissipation. • Insulate the battery from hot weather if necessary.
		Heater High Temperature Protection	<ul style="list-style-type: none"> • Restart the battery. • The heater MOSFET might have been damaged if the protection persists. Contact us for help.
		Heater High Temperature Hardware Protection	<ul style="list-style-type: none"> • Restart the battery. • The heater fuse has blown and the heater is no longer operable. But the battery can continue charging and discharging.
		AFE High Temperature Protection	<ul style="list-style-type: none"> • Increase the airflow for efficient heat dissipation. • Insulate the battery from hot weather if necessary.
		AFE Low Temperature Protection	<ul style="list-style-type: none"> • Insulate the battery from cold weather. • Warm up the battery with the heater or external heat sources.
		Temperature Sampling Error Protection	<ul style="list-style-type: none"> • Restart the battery. • The temperature sensor connection might have been loose if the protection persists. Contact us for help.

Troubleshooting

Phenomenon		Possible Causes	Solutions
Battery Status Indicator	Heater Status Indicator		
Slow Flash Red	Slow Flash Red	Fuse Permanent Failure	<ul style="list-style-type: none"> Restart the battery. The fuse has blown due to inrush currents if the permanent failure persists. Contact us for help.
Fast Flash Red	Fast Flash Red	Charge MOSFET Permanent Failure	<ul style="list-style-type: none"> Restart the battery. The charge MOSFET has been damaged due to voltage spikes if the permanent failure persists. Contact us for help.
		Discharge MOSFET Permanent Failure	<ul style="list-style-type: none"> Restart the battery. The discharge MOSFET has been damaged due to voltage spikes if the permanent failure persists. Contact us for help.
Strobe Red	Strobe Red	Cell Overvoltage Permanent Failure	<ul style="list-style-type: none"> Restart the battery. The battery has been severely overcharged and is no longer usable if the permanent failure persists. Replace the battery.
		Cell Undervoltage Permanent Failure	<ul style="list-style-type: none"> Restart the battery. The battery has been severely overdischarged and is no longer usable if the permanent failure persists. Replace the battery.
		Cell High Temperature Permanent Failure	<ul style="list-style-type: none"> Restart the battery. The battery has been severely overheated and is no longer usable if the permanent failure persists. Replace the battery.
Double Flash Red	Double Flash Red	Low SOH Permanent Failure	<ul style="list-style-type: none"> Restart the battery. The battery reaches the end of life if the permanent failure persists. Replace the battery.

Troubleshooting

Phenomenon		Possible Causes	Solutions
Battery Status Indicator	Heater Status Indicator		
Lights up/ Flashes According to the Battery Status	Solid Red	Heater Malfunction Warning	<ul style="list-style-type: none"> Restart the battery. The heater might have fell off due to vibration if the warning persists. Contact us for help.
		Heater Turns on and off Repeatedly	<ul style="list-style-type: none"> Ensure that the chargers are able to deliver a charge current greater than 15A to each battery in the battery bank. The heater is unable to operate properly with low current chargers. Ensure that the chargers are able to deliver a stable charge current. The heater is unable to operate properly with PWM charge controllers.
Unable to Turn on Battery		Cell Undervoltage Permanent Failure	<ul style="list-style-type: none"> The battery has been severely overdischarged and is no longer usable. Replace the battery.

Emergency Responses

Fire

Flooding

Smell

In the event of any threat to health or safety, always begin with the steps below before addressing other suggestions.

- Immediately contact the fire department or other relevant emergency response team.
- Notify all people who might be affected and ensure that they can evacuate the area.



WARNING

- ONLY perform the suggested actions below if it is safe to do so.

Fire

1. Disconnect the battery from the system.
2. Turn the battery off.
3. Put out the fire with a fire extinguisher. Acceptable fire extinguishers include water, CO₂, and ABC.



WARNING

- DO NOT use type D (flammable metal) fire extinguishers.

Flooding

1. Stay out of the water if any part of the battery or cable is submerged.
2. Disconnect the battery from the system.
3. Turn the battery off.
4. Protect the battery by finding and stopping the source of the water and pumping water away if possible.

Smell

1. Disconnect the battery from the system.
2. Turn the battery off.
3. Ensure that nothing is in contact with the battery.
4. Ventilate the installation space.

Technical Support

For additional support, contact the Renogy technical support team through renogy.com/contact-us. Have the following information available when contacting Renogy.

- Owner name
- Contact information
- Order number
- Purchase channel
- Serial number
- Brief description of the issue



Visit renogy.com to find relevant documentation or get more support.

US www.renogy.com

CN www.renogy.cn

UK uk.renogy.com

CA ca.renogy.com

AU au.renogy.com

JP renogy.jp

FR fr.renogy.com

DE de.renogy.com

ES es.renogy.com

KR kr.renogy.com

Technical Specifications

General	
Dimension	17.99 x 12.95 x 10.52 inch / 457.0 x 329.0 x 267.2 mm (Exclude Cable Glands and Integrated Cables)
Weight	112.44 lbs. / 51.0 kg
Operating Environment Temperature	59°F to 86°F / 15°C to 30°C (Recommended) -4°F to 122°F / -20°C to 50°C (Extreme)
Operating Relative Humidity	5% to 95%
Operating Altitude	<9842.5 ft. / <3000 m
Charge Temperature	-4°F to 122°F / -20°C to 50°C
Discharge Temperature	-4°F to 140°F / -20°C to 60°C
Storage Temperature	-4°F to 113°F / -20°C to 45°C
Storage Relative Humidity	5% to 95%
Input/Output Connector	Gray Anderson 350 Connector
Integrated Cable Size	4/0 AWG / 107 mm ²
Integrated Cable Length	23.62 inch / 600 mm (Include Anderson Connector and Cable Glands)
Communication Interface	LP16 Port (7-Pin), Bluetooth Module
Communication Protocol	RV-C (LP16 Port), MODBUS (Bluetooth Module)
Housing Material	Aluminum
Protection Rating	IP65
Cooling Method	Passive Cooling
Electrical	
Battery Type	Lithium Iron Phosphate
Nominal Voltage	12.8V
Rated Capacity	400Ah (0.2C, 25°C)
Rated Energy	5.12KWh (0.2C, 25°C)
Maximum Continuous Charge Current	5A (-20°C to 0°C) 200A (0°C to 15°C / 50°C to 55°C) 300A (15°C to 50°C)
Maximum Continuous Discharge Current	350A (-20°C to 60°C)
Cycle Life	3800 Cycles (80% DOD, 80% EOL, 0.2C, 25°C)
Internal Resistance	<10mΩ
Connection Method	Parallel (Up to 8)

Technical Specifications

Self-Discharge Rate	≤18%/Month (Turned On) ≤1.5%/Month (Turned Off)
Charger Setting	
Boost Voltage	14.4V
Float Voltage	14.4V/Disable
Equalization Voltage	3500W
Tail Current	20A
Peukert Exponent	1.01
Heater	
Heater Operating Temperature	>-20°C / >-4°F
Heater Power Rating	200W
Heater Heating Rate	5°C/h / 9°F/h

Dimensions

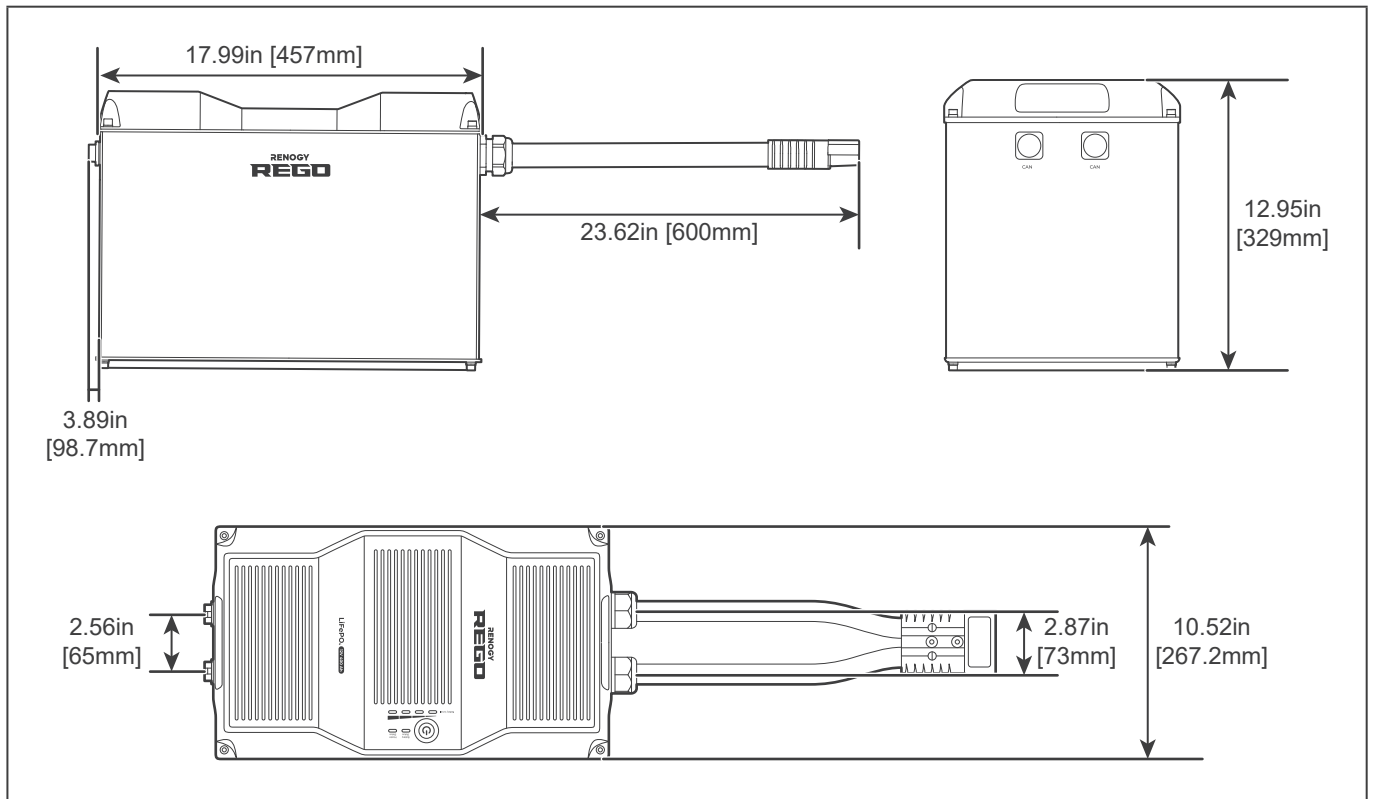

NOTE

- The dimension tolerance is ± 0.02 inch (± 0.5 mm)

FCC Statement

This device complies with Part 15 of the FCC Rules. FCC ID: 2ANPBRMLP4-G2. Operation is subject to the following two conditions:

- (1) This device may not cause harmful interference.
- (2) This device must accept any interference received, including interference that may cause undesired operation.

This equipment has been tested and found to comply with the limits for a Class B digital device, pursuant to Part 15 of the FCC Rules. These limits are designed to provide reasonable protection against harmful interference in a residential installation. This equipment generates, uses and can radiate radio frequency energy and, if not installed and used in accordance with the instructions, may cause harmful interference to radio communications. However, there is no guarantee that interference will not occur in a particular installation. If this equipment does cause harmful interference to radio or television reception, which can be determined by turning the equipment off and on, the user is encouraged to try to correct the interference by one or more of the following measures:

- (1) Orient or relocate the receiving antenna.
- (2) Increase the separation between the equipment and receiver.
- (3) Connect the equipment into an outlet on a circuit different from that to which the receiver is connected.
- (4) Consult the dealer or an experienced radio/TV technician for help.

FCC Radiation Exposure Statement

This equipment complies with FCC radiation exposure limits set forth for an uncontrolled environment. This equipment should be installed and operated with minimum distance 20cm between the radiator & your body.

Visit renogy.com to find relevant documentation or get more support via "[Contact Us](#)".
Renogy reserves the right to change the contents of this manual without notice.

Join the Renogy Power Plus Community
by downloading the DC Home App.
Find your e-warranty here, and more.

