

morphy richards®

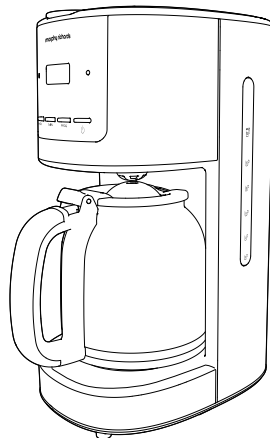

Filter Coffee Maker with Timer and Glass Carafe
Please read and keep these instructions



www.morphyrichards.com



Health & Safety

The use of any electrical appliance requires the following common sense safety rules.
Please read these instructions carefully before using the product.

- **WARNING: This appliance incorporates a heating element which is subject to residual heat after use.**
- This appliance is not intended for use by persons (including children) with reduced physical, sensory or mental capabilities, or lack of experience and knowledge, unless they have been given supervision or instruction concerning use of the appliance by a person responsible for their safety.
- Children should be supervised to ensure that they do not play with the appliance.
- Cleaning and user maintenance shall not be made by children.
- For care and cleaning, refer to 'Care and Cleaning' section.
- **WARNING: Misuse of appliance could cause personal injury.**
- The appliance has a heating element which is subject to residual heat after use.
- Keep the appliance and cord out of the reach of children.
- If the supply cable is damaged, it must be replaced by the manufacturer, its service agent or similarly qualified persons in order to avoid a hazard.
- This appliance is intended to be used in household and similar applications such as: farm houses, by clients in hotels, motels and other residential type environments; bed and breakfast type environments. It is not suitable for use in staff kitchen areas in shops, offices and other working environments.

Location

- Always locate your appliance away from the edge of the worktop.
- Ensure that the appliance is used on a firm, flat surface.
- Do not use the appliance outdoors or near water.
- **WARNING: Do not place the appliance onto a metal tray or metal surface whilst in use.**

Mains cable

- The supply cord should be regularly examined for signs of damage, and if the cord is damaged, the appliance must not be used.
- Do not let the mains cable hang over the edge of the worktop where a child could reach it.
- Do not let the mains cable run across an open space e.g. between a low socket and a table.
- Do not let the mains cable run across a cooker or other hot area which might damage the cable.
- The mains cable should reach from the socket to the base unit without straining the connections.

Personal safety

- **WARNING: To protect against fire, electric shock and personal injury do not immerse cord, plug and appliance in water or any other liquid.**
- The temperature of accessible surfaces may be high when the appliance is operating.
- Unplug from the outlet before cleaning.
- Allow to cool before putting on or taking off parts and before cleaning.
- Do not move the Coffee Maker while switched on.

Other safety considerations

- The use of attachments or tools not recommended or sold by Morphy Richards, may cause fire, electric shock or injury.
- Do not use the appliance for any use other than its intended purpose.
- Do not place the appliance on or near a hot gas or electric burner or in a heated oven.
- **WARNING: The appliance must not be immersed for cleaning.**
- **CAUTION:** To prevent damage to the appliance, do not use alkaline cleaning agents when cleaning. Use a soft cloth and detergent.

Electrical requirements

WARNING: This appliance must be earthed.

AUS

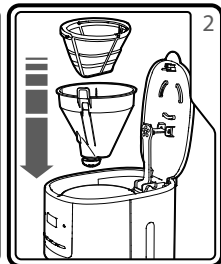
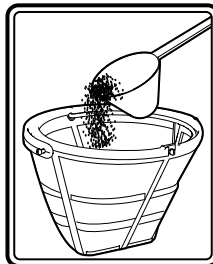
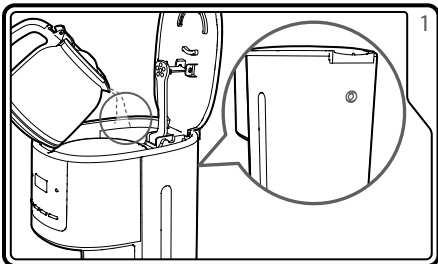
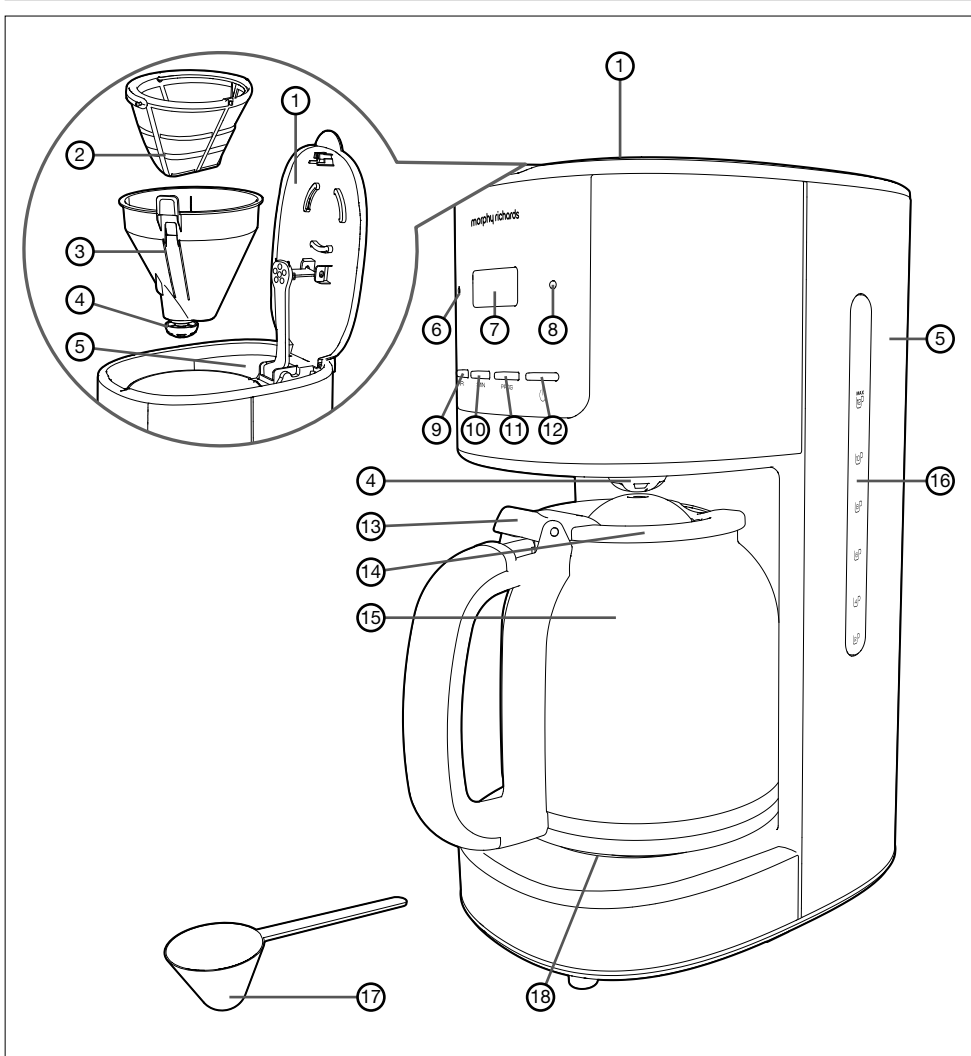

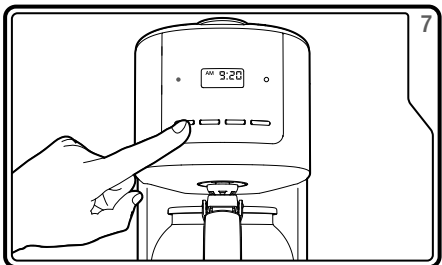
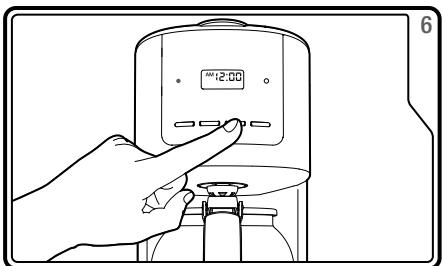
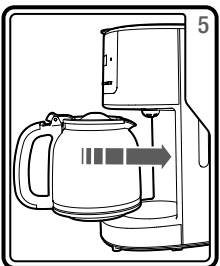
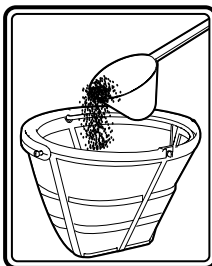
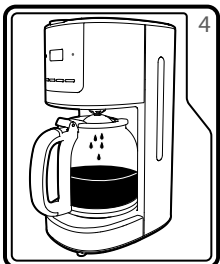
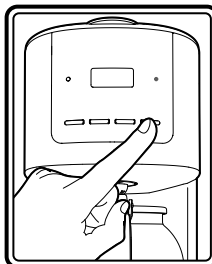
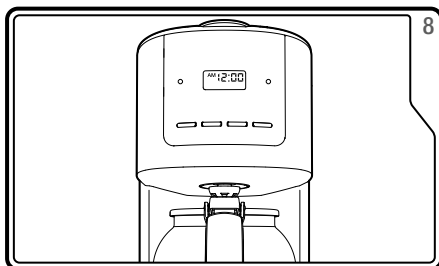
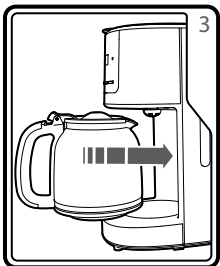
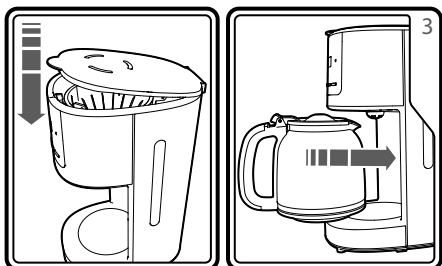

Features

- (1) Lid
- (2) Removable Permanent Filter
- (3) Removable Filter Holder
- (4) Coffee Dispenser Valve
- (5) Water Reservoir
- (6) Green Programme Light
- (7) Display Screen
- (8) Red Heating Light
- (9) Hour Button
- (10) Minute Button
- (11) Auto/Prog Button
- (12) On/Off Button
- (13) Lid Open Lever
- (14) Carafe Lid
- (15) Glass Carafe
- (16) Water Gauge
- (17) Coffee Spoon
- (18) Hotplate

AUS

Before First Use

- Take your Coffee Maker out of the box and remove the packaging.
- Wash the detachable parts of the machine in warm soapy water.
- The first time you use your Coffee Maker, operate the Coffee Maker with water only.

Setting the Clock

- When the Coffee Maker is plugged in, 12:00 AM will appear on the Display Screen (7).
- To set the time, use the Hour (9) and Minute (10) Buttons. The display is a 12 hour clock.
- When the Coffee Maker is in standby mode, you can use the Hour and Minute Buttons to adjust the clock.

Using Your Coffee Maker

- 1** Fill the Water Reservoir (5) with cold water. Do not overfill.
If the Water Reservoir (5) is overfilled, the water will overflow from a hole on the back of the product.
- 2** Use the Coffee Spoon (17) to add filter coffee into the Removable Permanent Filter (2). We recommend 7g (one spoon) of coffee per cup, use more ground coffee if you desire a stronger flavour. Place the Filter into the Removable Filter Holder (3) in the Coffee Maker.
- 3** Close the Lid (1) and replace the Glass Carafe (15) into the Coffee Maker.
- 4** Press the On/Off Button (12) to start the brewing process, the Red Heating Light (8) will illuminate. To stop the brewing process, press the On/Off Button a second time.

Alternatively, not pressing the On/Off Button a second time allows the unit to automatically enter Keep Warm mode for 30 minutes.

To Pre-set a Brewing Time

- 5** Follow 'Using your Coffee Maker' steps 1-3 on page 4.
- 6** Press the Auto/Prog Button (11) so that the Green Programme Light (6) illuminates and 12:00 AM flashes on the Display Screen (7).
- 7** Select the brewing start time using the Hour (9) and Minute (10) Buttons.
- 8** When you have selected the desired time, wait until the time and the Green Programme Light (6) stop flashing. Once set, the Display Screen will return to displaying the current time.

To activate the timer, press and hold the Auto/Prog Button (11) for approximately 5 seconds. The Green Programme Light (6) will illuminate and the programme is set.

Refilling Your Coffee Maker

- Allow 3 minutes to cool before refilling with cold water.

Keep Warm

After the brewing cycle has finished, your Coffee Maker will activate the keep warm function which will keep your coffee warm for approximately 30 minutes.

The On/Off Button (12) will remain illuminated, then switch off when the keep warm cycle has finished.

To switch the keep warm mode off press the On/Off Button.

Cleaning Your Coffee Maker

- Unplug the Coffee Maker and allow to cool.
- Do not immerse the Coffee Maker in liquid.
- Rinse the Water Reservoir (5) occasionally with cold water. Do not use a cloth as any residue or lint may be left behind to clog the Coffee Maker.
- Remove the Permanent Filter (2), discard any used coffee and wash. Extended soaking helps to remove coffee stains from the mesh.
- Wash the Glass Carafe (15), Carafe Lid (14), and Removable Filter Holder (3) in warm soapy water. Rinse and dry all parts thoroughly. Refit the Permanent Filter (2) and Filter Holder.
- Wipe all external surfaces with a damp cloth and dry thoroughly.
- Care must be taken to ensure that the non-drip Coffee Dispenser Valve (4) situated on the bottom of the Removable Filter Holder is not damaged during cleaning.
- Never use harsh or abrasive cleaners.
- NO parts are suitable for cleaning in a dishwasher.

Descaling

- If you live in a hard water area, we recommend that your Coffee Maker is descaled at regular intervals, e.g. every 1-2 months. In areas of moderately hard water, you should descale every 6 months.
- If the water filters through more slowly than usual, or if water still remains in the reservoir at the end of a cycle, it is a sign that descaling is necessary.
- We recommend you use a proprietary liquid descaler which is especially made for coffee makers and plastic kettles. Follow the instructions on the bottle or sachet, and then operate the Coffee Maker with just water 3 times before making coffee.
- Do not use a kettle descaler unless the packet specifically states it is suitable for Coffee Makers.

Note: The Removable Permanent Filter should not

Contact Us

Helpline

If you are having a problem with your appliance, please call our Helpline, as we are more likely to be able to help than the store you purchased the item from.

Please have the product name, model number and serial number to hand when you call to help us deal with your enquiry quicker.

Talk To Us

If you have any questions or comments, or want some great tips or recipe ideas to help you get the most out of your products, join us online:

Blog: www.homeofthehouseproud.com

Facebook: www.facebook.com/morphyrichardsuk

Twitter: www.twitter.com/loveyourmorphy

Website: www.morphyrichards.com

THIS SECTION IS ONLY APPLICABLE FOR CUSTOMERS IN UK AND IRELAND

REGISTERING YOUR TWO YEAR GUARANTEE

Your standard one year guarantee is extended for an additional 12 months when you register the product within 28 days of purchase with Morphy Richards. If you do not register the product with Morphy Richards within 28 days, your product is guaranteed for 1 year. To validate your 2 year guarantee register with us online at www.morphyrichards.co.uk

N.B. Each qualifying product needs to be registered with Morphy Richards individually. Please refer to the one year guarantee for more information.

YOUR ONE YEAR GUARANTEE

It is important to retain the retailer's receipt as proof of purchase. Staple your receipt to this back cover for future reference. Please quote the following information if the product develops a fault. These numbers can be found on the base of the product.

Model no.
Serial no.

All Morphy Richards products are individually tested before leaving the factory. In the unlikely event of any appliance proving to be faulty within 28 days of purchase, it should be returned to the place of purchase for it to be replaced. If the fault develops after 28 days and within 12 months of original purchase, you should contact the Helpline number quoting Model number and Serial number on the product, or write to Morphy Richards at the address shown. You may be asked to return a copy of proof of purchase. Subject to the exclusions set out below (see Exclusions), the faulty appliance will then be repaired or replaced and dispatched usually within 7 working days of receipt. If, for any reason, this item is replaced during the 1 year guarantee period, the guarantee on the new item will be calculated from original purchase date. Therefore it is vital to retain your original till receipt or invoice to indicate the date of initial purchase. To qualify for the 1 year guarantee, the appliance must have been used according to the instructions supplied. For example, crumb trays should have been emptied regularly.

EXCLUSIONS

Morphy Richards shall not be liable to replace or repair the goods under the terms of the guarantee where:

- 1 The fault has been caused or is attributable to accidental use, misuse, negligent use or used contrary to the manufacturer's recommendations or where the fault has been caused by power surges or damage caused in transit.
- 2 The appliance has been used on a voltage supply other than that stamped on the products.
- 3 Repairs have been attempted by persons other than our service staff (or authorised dealer).
- 4 The appliance has been used for hire purposes or non domestic use.
- 5 The appliance is second hand.

- 6 Morphy Richards are not liable to carry out any type of servicing work, under the guarantee.
- 7 Plastic filters for all Morphy Richards kettles and coffee makers are not covered by the guarantee.
- 8 Batteries and damage from leakage are not covered by the guarantee.
- 9 The filters have not be cleaned and replaced as instructed.

This guarantee does not confer any rights other than those expressly set out above and does not cover any claims for consequential loss or damage. This guarantee is offered as an additional benefit and does not affect your statutory rights as a consumer.

YOUR INTERNATIONAL TWO YEAR GUARANTEE

This appliance is covered by two-year repair or replacement warranty.

It is important to retain the retailers receipt as proof of purchase. Staple your receipt to this back cover for future reference.

Please quote the following information if the product develops a fault. These numbers can be found on the base of the product.

Model no.
Serial no.

All Morphy Richards products are individually tested before leaving the factory. In the unlikely event of any appliance proving to be faulty within 28 days of purchase it should be returned to the place of purchase for it to be replaced.

If the fault develops after 28 days and within 24 months of original purchase, you should contact your local distributor quoting Model number and Serial number on the product, or write to your local distributor at the addresses shown.

You will be asked to return the product (in secure, adequate packaging) to the address below along with a copy of proof of purchase.

Subject to the exclusions set out below (1-9) the faulty appliance will then be repaired or replaced and dispatched usually within 7 working days of receipt.

If for any reason this item is replaced during the 2-year guarantee period, the guarantee on the new item will be calculated from original purchase date. Therefore it is vital to retain your original till receipt or invoice to indicate the date of initial purchase.

To qualify for the 2-year guarantee the appliance must have been used according to the manufacturers instructions. For example, appliances must have been descaled and filters must have been kept clean as instructed.

The local distributor shall not be liable to replace or repair the goods under the terms of the guarantee where:

- 1 The fault has been caused or is attributable to accidental use, misuse, negligent use or used contrary to the manufacturers recommendations or where the fault has been caused by power surges or damage caused in transit.
- 2 The appliance has been used on a voltage supply other than that



stamped on the products.

- 3 Repairs have been attempted by persons other than our service staff (or authorised dealer).
- 4 Where the appliance has been used for hire purposes or non domestic use.
- 5 The appliance is second hand.
- 6 The local distributor are not liable to carry out any type of servicing work, under the guarantee.
- 7 The guarantee excludes consumables such as bags, filters and glass carafes.
- 8 Batteries and damage from leakage are not covered by the guarantee.
- 9 The filters have not been cleaned and replaced as instructed.

This guarantee does not confer any rights other than those expressly set out above and does not cover any claims for consequential loss or damage. This guarantee is offered as an additional benefit and does not affect your statutory rights as a consumer.

AUSTRALIAN WARRANTY

This appliance is guaranteed for 2 years against faulty material, components and workmanship.

This warranty is in addition and does not affect your statutory rights.

Proof of purchase must be produced for any warranty benefit.

In the unlikely event of any appliance proving to be faulty, securely pack and return the item to the place of purchase accompanied by the original receipt or invoice.

Our goods come with guarantees that cannot be excluded under the Australian Consumer Law. You are entitled to a replacement or refund for a major failure and for compensation for any other reasonably foreseeable loss or damage. You are also entitled to have the goods repaired or replaced if the goods fail to be of acceptable quality and the failure does not amount to a major failure.

NOT COVERED BY THIS WARRANTY

(Australian only)

- If the appliance has not been used in accordance with the manufacturers' recommendations or Instructions.
- If the fault is deemed to be caused by abuse, misuse, neglect, modifications or in proper use and or care
Eg: Kettles: Excessive build up of scale.
Toasters: Excessive build up of crumbs or foreign matter etc.
- Connection to incorrect voltage to that stamped on the product.
- Unauthorised repairs.
- Appliance used other than for domestic purposes.
- Excluding bags, filters, glass, carafes, and cutting blades.
- Freight and insurance costs.

If for any reason this item is replaced during the 2 year guarantee period, the guarantee on the new item will be calculated from original purchase date. Therefore it is vital to retain your original receipt or invoice to indicate the date of original purchase.

Morphy Richards's policy is to continually improve quality design and product quality. The company therefore reserves the right to change any specifications or to carry out modifications as deemed worthy at any time.

The Australian supplier reserves the right to repair, modify, exchange or replace the faulty appliance with the same or similar model or product of equivalent value.

- GB** Morphy Richards products are intended for household use only. Morphy Richards has a policy of continuous improvement in product quality and design. The Company, therefore, reserves the right to change the specification of its models at any time.

The After Sales Division,

Morphy Richards Ltd, Mexborough, South Yorkshire, England, S64 8AJ
Helpline (office hours) UK 0845 871 0960 Republic of Ireland 1800 409119

AUS Glen Dimplex Australia

1340 Ferritree Gully Road, Scoresby, Victoria 3179
T : 1300 556 816
E : sales@glendimplex.com.au

NZ Glen Dimplex New Zealand

38 Harris Road, East Tamaki, Auckland, New Zealand
T : 09 2748265
E : sales@glendimplex.co.nz

morphy richards®

CM16200MAUS Rev 1 11/19

www.morphyrichards.com