

# ***Shark***

## **Anti Hair Wrap & DuoClean® Cordless Vacuum**

IZ201UK Series  
IZ251UK Series

### **INSTRUCTIONS**

---



# THANK YOU

for purchasing the Shark® Anti Hair Wrap & DuoClean® Cordless Vacuum



To benefit from your product's extended guarantee, simply **register your purchase** at:

[sharkclean.co.uk/register-guarantee](http://sharkclean.co.uk/register-guarantee)

0800 862 0453

Scan QR code using mobile device

Please note, products purchased directly from Shark® are automatically registered.

## RECORD THIS INFORMATION

Model Number: \_\_\_\_\_

Date of Purchase (Keep receipt): \_\_\_\_\_

Store of Purchase: \_\_\_\_\_

## TECHNICAL SPECIFICATIONS

Voltage: 25.2V<sup>---</sup>

## PLEASE READ CAREFULLY AND KEEP FOR FUTURE REFERENCE.

This instruction manual is designed to help you get a complete understanding of your new Shark DuoClean® Cordless Vacuum.

If you have any questions, please call the Customer Service line on 0800 862 0453.

# CONTENTS

<b>Important Safety Instructions</b> .....	<b>4</b>
<b>Assembling your Shark® Vacuum Cleaner</b> .....	<b>6</b>
<b>Using Your Lithium ION Power Pack Battery</b> .....	<b>7</b>
LED battery Power and Charging Indicators.....	7
Recycling your Lithium ION Power Pack Battery.....	7
<b>Charging Your Lithium ION Power Pack Battery</b> .....	<b>8</b>
<b>Using Smart Response Technology</b> .....	<b>9</b>
<b>Cleaning Modes</b> .....	<b>10</b>
<b>Using the Flexology® Wand</b> .....	<b>11</b>
Flexology® Reach.....	11
Flexology® Storage.....	11
<b>Maintaining your Vacuum Cleaner</b> .....	<b>12</b>
Emptying the Dust Cup.....	12
Removing and Cleaning the Dust Cup.....	12
Cleaning the Filters.....	13
Maintaining the Floor Nozzle.....	14
Checking for blockages.....	15
<b>Troubleshooting Guide</b> .....	<b>16</b>
<b>Additional Accessories Available</b> .....	<b>17</b>
<b>Guarantee</b> .....	<b>18</b>
<b>Battery Guarantee</b> .....	<b>19</b>

 This marking indicates that this product should not be disposed with other household wastes throughout the EU. To prevent possible harm to the environment or human health from uncontrolled waste disposal, recycle it responsibly to promote the sustainable reuse of material sources. To return your used device, please use the return and collection systems or contact the retailer where this product was purchased. They can take this product for environmental safe recycling.

# IMPORTANT SAFETY INSTRUCTIONS

FOR HOUSEHOLD USE ONLY • PLEASE READ ALL INSTRUCTIONS BEFORE USING THIS VACUUM.

To reduce the risk of shock and unintended operation, turn off power and remove the ION Power Pack battery before servicing.

## ⚠ WARNING

REDUCE THE RISK OF FIRE, ELECTRIC SHOCK, INJURY, OR PROPERTY DAMAGE:

- 1 This vacuum consists of a motorized nozzle, wand, and handheld vacuum. These components contain electrical connections, electrical wiring, and moving parts that potentially present risk to the user.
  - 2 Before each use, carefully inspect all parts for any damage. If a part is damaged, discontinue use.
  - 3 Use only identical replacement parts.
  - 4 This vacuum contains no serviceable parts.
  - 5 Use only as described in this manual. **DO NOT** use the vacuum for any purpose other than those described in this manual.
  - 6 With the exception of the filters and dust cup, **DO NOT** expose any parts of the vacuum to water or other liquids.
  - 7 **DO NOT allow the appliance to be used by children.** Keep the appliance and its cord out of reach of children. Do not allow to be used as a toy. Close supervision is necessary when used near children. Cleaning and user maintenance shall not be done by children.
- ### GENERAL USE
- 8 This appliance can be used by persons with reduced physical, sensory or mental capabilities or lack of experience and knowledge if they have been given supervision or instruction concerning use of the appliance in a safe way and understand the hazards involved.
  - 9 Always turn off the vacuum before connecting or disconnecting any current carrying hoses, motorized nozzles, chargers, batteries, or other electrical or mechanical parts.
  - 10 **DO NOT** handle plug or vacuum with wet hands.
  - 11 **DO NOT** use without dust cup, filters, and brush-roll in place.
  - 12 Only use Shark® branded filters and accessories. Use of non-Shark® parts may invalidate your guarantee.
  - 13 **DO NOT** put any objects into nozzle or accessory openings. **DO NOT** use with any opening blocked; keep free of dust, lint, hair, and anything that may reduce airflow.
  - 14 **DO NOT** use if nozzle or accessory airflow is restricted. If the air paths or the motorized floor nozzle become blocked, turn the vacuum off. Remove all obstructions before you turn on the unit again.
  - 15 Keep nozzle and all vacuum openings away from hair, face, fingers, uncovered feet, or loose clothing.
  - 16 **DO NOT** use if vacuum is not working as it should, or has been dropped, damaged, left outdoors, or dropped into water.
  - 17 Use extra care when cleaning on stairs.
  - 18 **DO NOT** leave the vacuum unattended while powered on.
  - 19 When powered on, keep the vacuum moving over the carpet surface at all times to avoid damaging the carpet fibres.

- 20 If you have delicate or wool carpets, particularly loop pile, please try the vacuum on a hidden area first to ensure the spinning brush-rolls do not damage or unpick carpet fibres.
- 21 **DO NOT** place vacuum on unstable surfaces such as chairs or tables.
- 22 **DO NOT** use to pick up:
  - a) Liquids
  - b) Large objects
  - c) Hard or sharp objects (glass, nails, screws, or coins)
  - d) Large quantities of dust (including drywall, fireplace ash, or embers). **DO NOT** use as an attachment to power tools for dust collection.
  - e) Smoking or burning objects (hot coals, cigarette butts, or matches)
  - f) Flammable or combustible materials (lighter fluid, gasoline, or kerosene)
  - g) Toxic materials (chlorine bleach, ammonia, or drain cleaner)
- 23 **DO NOT** use in the following areas:
  - a) Poorly lit areas
  - b) Wet or damp surfaces
  - c) Outdoor areas
  - d) Spaces that are enclosed and may contain explosive or toxic fumes or vapors (lighter fluid, gasoline, kerosene, paint, paint thinners, mothproofing substances, or flammable dust)
- 24 Turn off the vacuum before plugging in or unplugging the charger.
- 25 Turn off the vacuum before any adjustment, cleaning, maintenance or troubleshooting.
- 26 During cleaning or routine maintenance, **DO NOT** cut anything other than hair, fibers, or string wrapped around the brush-roll.
- 27 Allow all filters to air-dry completely before replacing in the vacuum to prevent liquid from being drawn into electric parts.
- 28 **DO NOT** modify or attempt to repair the vacuum or the battery yourself, except as indicated in this manual. **DO NOT** use the battery or vacuum if it has been modified or damaged. Damaged or modified batteries may exhibit unpredictable behavior resulting in fire, explosion or risk of injury.

- 29 Turn off all controls before unplugging.
- 30 Always turn off this appliance before connecting or disconnecting motorized nozzle or hand tool.

### BATTERY PACK

- 31 The battery is the power source for the vacuum. Carefully read and follow all charging instructions.
- 32 To prevent unintentional starting, ensure the vacuum is powered off before picking up or carrying the vacuum. **DO NOT** carry the appliance with your finger on the power switch.
- 33 Use only Dong Kun chargers DK33-288080H-B or Yinli YLS0483A-U2880802. Use of an incorrect charger may result in no charging, and/or unsafe conditions. Use only Shark® battery XSBT700EU.
- 34 Keep the battery away from all metal objects such as paper clips, coins, keys, nails, or screws. Shorting the battery terminals increases the risk of fire or burns.
- 35 Under abusive conditions, liquid may be ejected from the battery. Avoid contact with this liquid, as it may cause irritation or burns. If contact occurs, flush with water. If liquid contacts eyes, seek medical help.
- 36 Battery should not be stored at temperatures below 37.4°F (3°C) or above 104°F (40°C) to maintain long-term battery life.
- 37 **DO NOT** charge battery at temperatures below 40°F (5°C) or above 104°F (40°C).
- 38 Store the appliance indoors. **DO NOT** use or store it below 37.4°F (3°C). Ensure the appliance is at room temperature before operating.
- 39 **DO NOT** expose the battery to fire or temperatures above 265°F (130°C) as it may cause explosion.

## SAVE THESE INSTRUCTIONS

## ASSEMBLING YOUR SHARK® VACUUM CLEANER

1. Insert the wand into the floor nozzle, pressing it in until it clicks securely into place.
2. Insert the handheld vacuum into the top of the wand, pressing it in until it clicks securely into place.

For proper operation, ensure all components are completely connected and clicked into place..

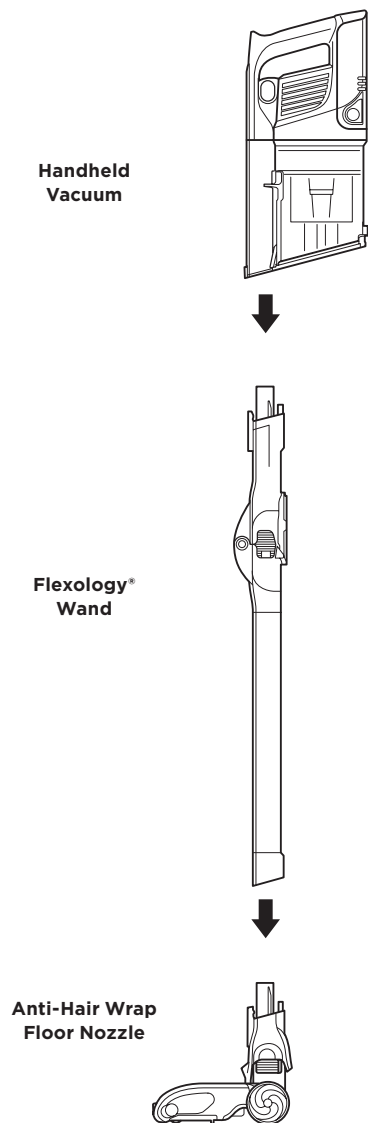

**WARNING:** This vacuum does not stand up on its own. For storage instruction please refer to page 11.

## USING YOUR LITHIUM ION POWER PACK BATTERY

The **Lithium Ion Power Pack battery does not come fully charged.** Prior to first use, charge completely. During first use, run the battery down until it is completely out of power. This will condition the battery.

### LED BATTERY POWER AND CHARGING INDICATORS

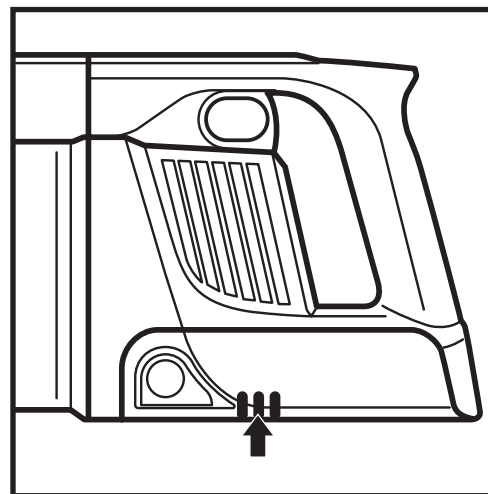

#### Charging



**NOTE:** Full charge takes approximately 3 hours.

#### In Use



### RECYCLING YOUR LITHIUM ION POWER PACK BATTERY

This product uses a lithium-ion rechargeable and recyclable battery. When the battery no longer holds a charge, it should be removed from the vacuum and recycled. **DO NOT** incinerate or compost the battery.

When your Lithium ION Power Pack Battery needs to be replaced, dispose of it or recycle it in accordance with local regulations. In some areas, it is illegal to place spent lithium-ion batteries in the bin or in a municipal solid waste stream. Return spent power packs to an authorised recycling center or to retailer for recycling. Contact your local recycling center for information on where to drop off the spent power pack.

**NOTE:** A complete charge takes approximately 3 hours. The Lithium Ion Power Pack, like all lithium-Lithium Ion batteries, will naturally decrease in capacity over time from the 100% capacity of a new battery.

## CHARGING YOUR LITHIUM ION POWER PACK BATTERY

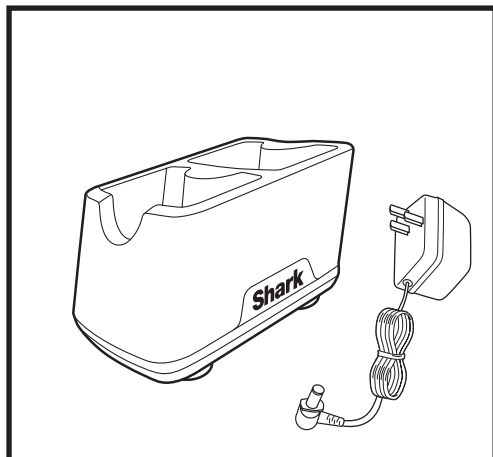

LITHIUM ION POWER PACK CHARGER

Plug the **Lithium Ion Power Pack Charger** into a wall socket.

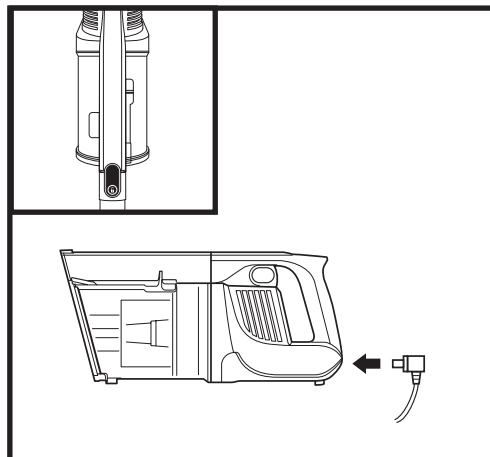

IN HANDHELD VACUUM

Remove the handheld vacuum from the wand by pressing the **Wand Release** button and pulling up. Plug the charger into the charging port on the handheld vacuum.

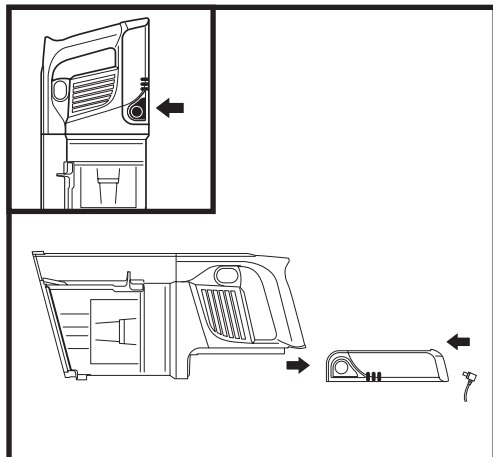

OUT OF THE VACUUM

To remove the battery, squeeze the **Battery Release Button** and slide backwards. Plug the charger into the charging port on the battery.

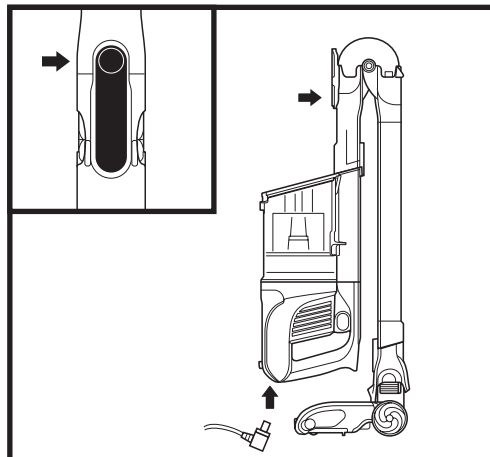

FLEXOLOGY® STORAGE MODE

To put the vacuum in storage mode, press the **Unlock** latch while folding the handheld vacuum forward until the wand clicks and locks. Plug the charger into the charging port on the handheld vacuum.

## USING SMART RESPONSE TECHNOLOGY

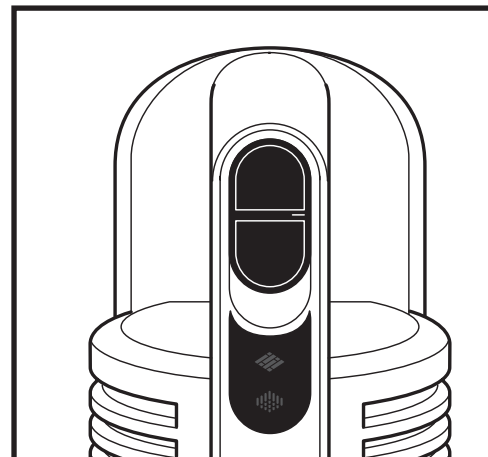

OFF

Slide switch to the top to turn off power. To begin vacuuming, slide switch to the desired setting.

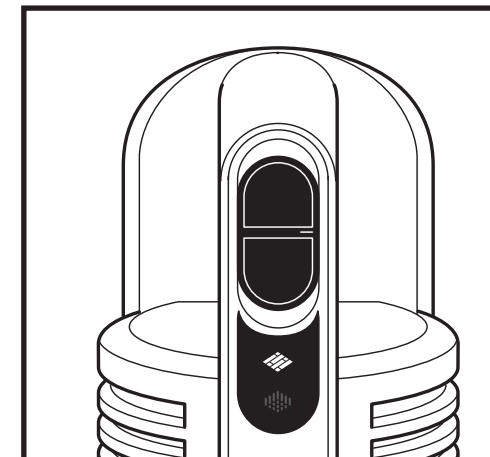

HARD FLOOR SETTING

**Hard Floor/Small Area Rugs**  
Use this setting to clean floors and small area rugs.

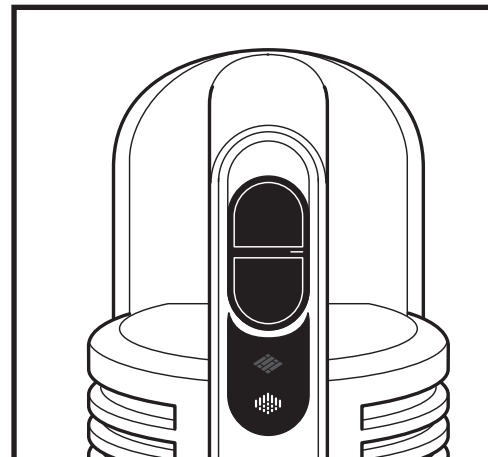

CARPET SETTING

**Carpet**  
Use this setting to pick up debris below the surface of your carpets.

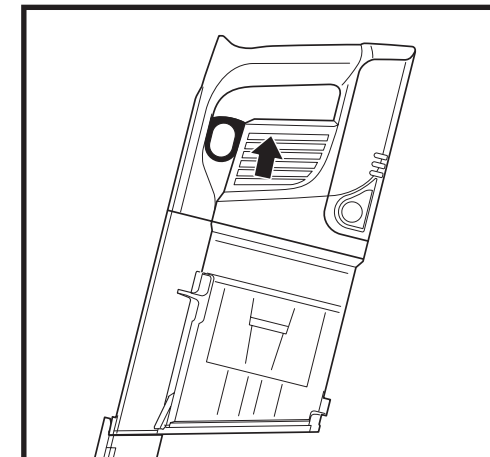

BOOST MODE

For an added boost in power, pull the **Trigger** on the handheld vacuum. Release it to return to Ion Power Mode.

Boost mode is available in both Carpet and Hard Floor setting

## CLEANING MODES

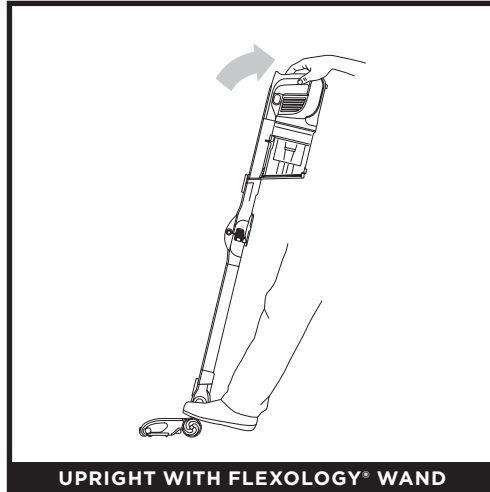

To clean floors, place foot on floor nozzle and tilt handheld vacuum back.

**NOTE:** Brush-roll will only engage when the handheld vacuum and wand are tilted back.

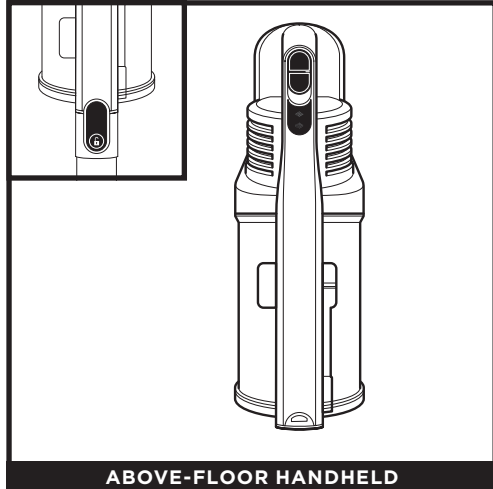

Press the wand release button to lift the handheld vacuum off the wand. Great for cleaning stairs and furniture, and other above floor areas with accessories.

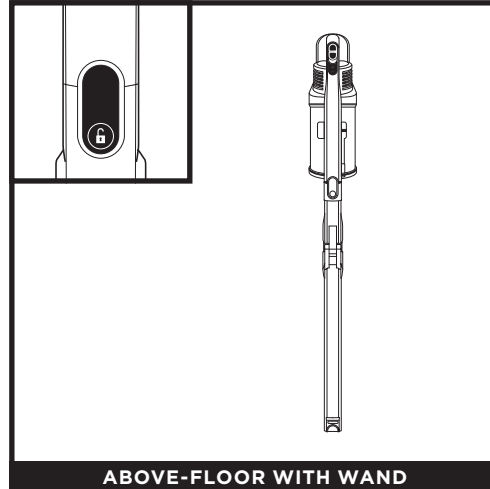

Stand the vacuum upright and press the nozzle release button where the bottom of the wand meets the nozzle. Lift upward to detach. Great for cleaning baseboards, ceiling fans, window sills, and other hard-to-access areas.

**NOTE:** All accessories are compatible with both the wand and the handheld vacuum.

## USING THE FLEXOLOGY® WAND

### FLEXOLOGY® REACH

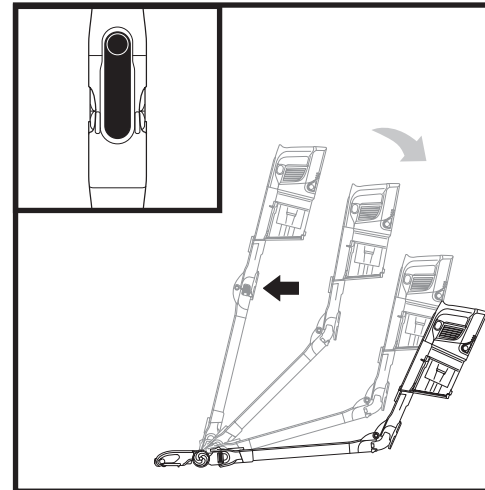

Press the **Flexology® Wand Unlock Latch** on the back of the wand then adjust the angle.

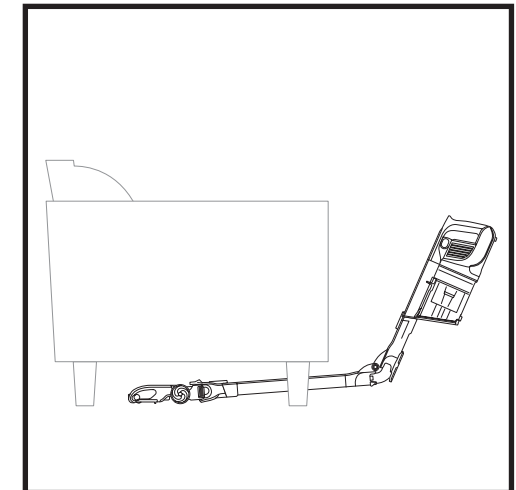

Adjust the wand to a lower angle to easily clean under furniture.

### FLEXOLOGY® STORAGE

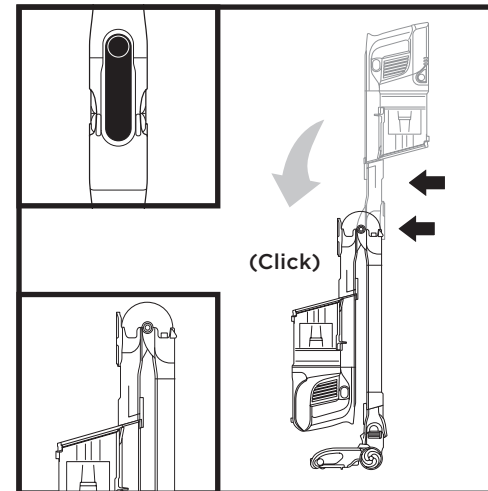

To put the vacuum in storage mode, press the unlock latch while folding the handheld vacuum forward until the wand clicks and locks.

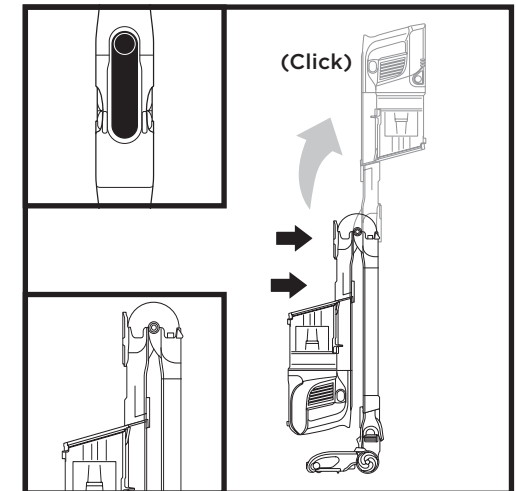

To take the vacuum out of storage mode, lift up the handheld vacuum until the wand clicks and locks in place.

**NOTE:** Take care whenever folding or unfolding the wand to ensure fingers cannot be caught in the mechanism.

## MAINTAINING YOUR VACUUM CLEANER

### EMPTYING THE DUST CUP

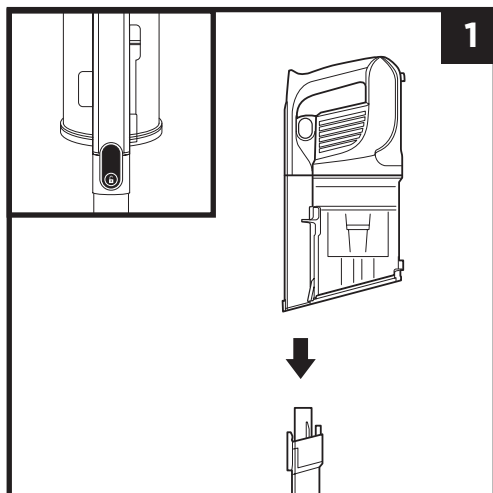

Press the handvac release button and disconnect the handheld vacuum from the wand.

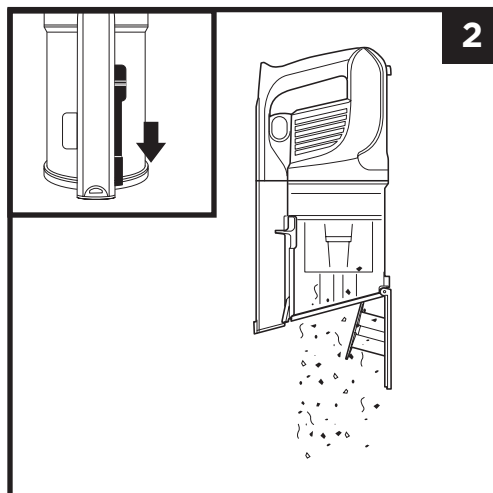

To empty the **Dust Cup** while it is attached to the handheld vacuum, position the dust cup over a dust bin and slide the **Lid Release** slider forward.

### REMOVING AND CLEANING THE DUST CUP

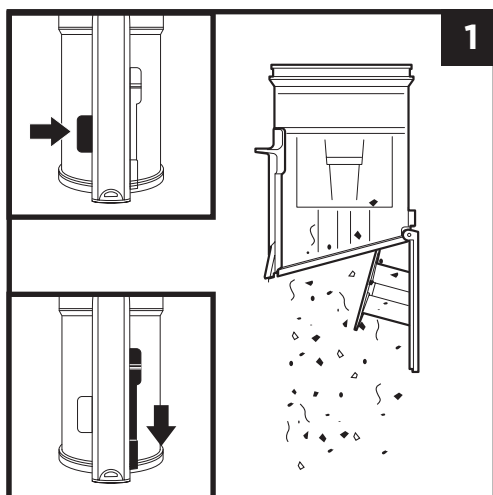

To remove the dust cup from the handheld vacuum, press the **Dust Cup Release** button near the handheld vacuum nozzle. Tilt the dust cup and lift off to remove. To empty dust and debris, hold the dust cup over the bin, then slide the **Lid Release** slider forward.

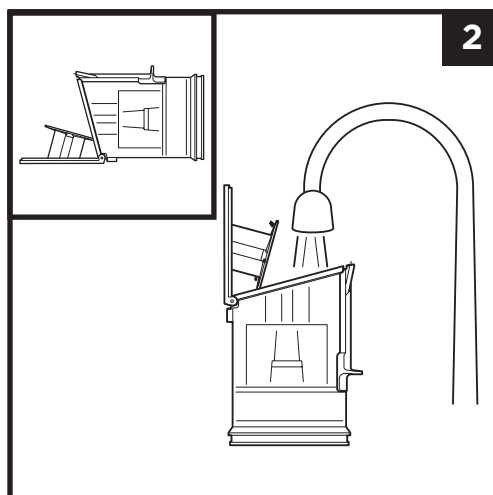

Remove debris from the dust screen by tapping it gently or wiping it with a dry cloth as needed. To clean the interior of the dust cup, rinse it with water. Place it on its side to air-dry for at least 24 hours before reinstalling.

## MAINTAINING YOUR VACUUM CLEANER

### CLEANING THE FILTERS

To clean filters, rinse them with water only. Allow all filters to air-dry completely for at least 24 hours before reinstalling to prevent liquid from being drawn into electric parts. Clean the pre-motor filters at least once a month and post-motor filter at least once a year. Tap off loose dirt between washes when needed. More frequent cleaning may sometimes be necessary with heavy use.

**IMPORTANT: DO NOT** use soap when cleaning the filters. Use water only.

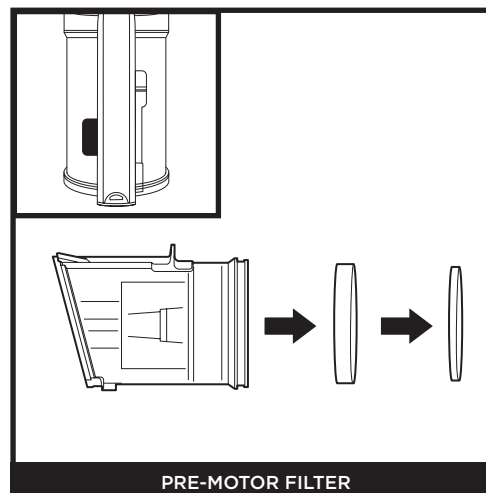

Press the dust cup release button and remove the dust cup. Pull the foam and felt filters out of the back of the dust cup.

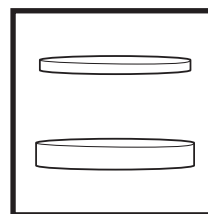

Pre-Motor Foam and Felt Filter Kit

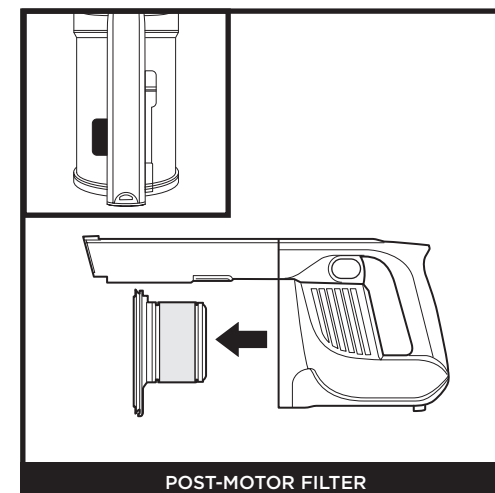

Remove the dust cup. Pull the post-motor filter out of the handheld vacuum.

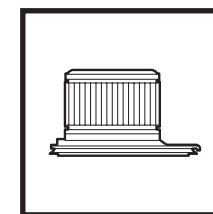

Post-Motor Filter

**NOTE:** To order filters and other parts, visit [sharkclean.co.uk](http://sharkclean.co.uk)

## MAINTAINING YOUR VACUUM CLEANER

### MAINTAINING THE FLOOR NOZZLE

If you run over a hard or sharp object or notice a noise change while vacuuming, check for blockages or objects caught in the brush-roll.

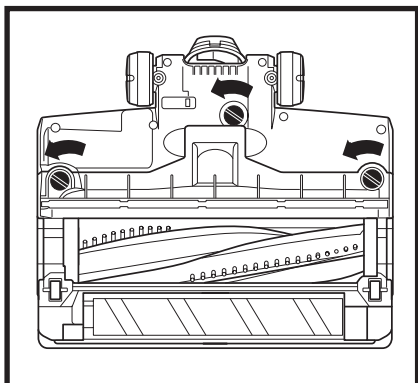

ANTI-HAIR WRAP FLOOR NOZZLE

1. Turn off the vacuum.
2. Using a coin, turn locks counterclockwise to open, then lift off cover to access brush-roll.
3. Clear airway of blockages.
4. Replace cover by sliding inserts into slots, then pressing down firmly on all sides before turning locks clockwise to close. There will be an audible click once the locks are secured.

**NOTE:** Anti Hair Wrap Technology removes hair from your brush-roll continuously as you vacuum. At times you may see small amounts of hair around the brush-roll - simply continue vacuuming and the comb and suction will remove the hair as you clean.

## MAINTAINING YOUR VACUUM CLEANER

### CHECKING FOR BLOCKAGES

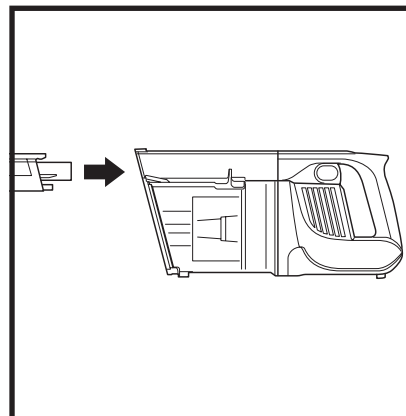

#### Checking for Blockages in the Handheld Vacuum:

1. Turn off vacuum.
2. Remove the handheld vacuum from the wand.
3. Check all intake openings to the dust cup and remove any debris or blockage.

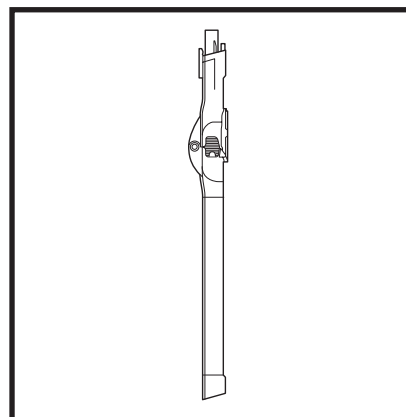

#### Checking for Blockages in the Wand:

##### Flexology® Wand:

1. Turn off vacuum.
2. Remove the handheld vacuum and floor nozzle from the wand.
3. Check the clog access on the Flexology® portion of the wand by pinching the tabs on either side of the hose and lifting the hose out for wand access.
4. Clear any debris and blockages.

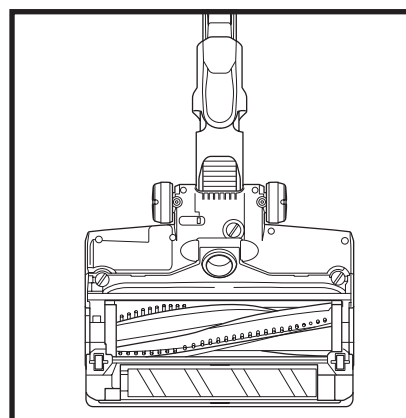

#### Checking for Blockages in the Floor Nozzle:

1. Turn off vacuum.
2. Detach the wand.
3. Use the edge of a coin to open the three locks on the bottom of the floor nozzle (see page 12).
4. Remove the cover and tilt back the neck of the floor nozzle.
5. Check the opening and remove any debris or blockage.
6. Replace cover by firmly pressing down on all sides and turn the locks counter clockwise.

## TROUBLESHOOTING GUIDE

**⚠ WARNING: To reduce the risk of shock and unintended operation, turn off power and remove the Lithium Ion Power Pack battery before servicing.**

**Vacuum is not picking up debris. No suction or light suction. Nozzle light is red.**  
(Refer to **Checking for Blockages** section for more information.)

- Check filters to see if they need cleaning. Follow instructions for rinsing and completely air-drying the filters before reinserting in the vacuum.
- Dust cup may be full; empty dust cup.
- Check floor nozzle for blockages; clear blockages if required.
- Remove any string, carpet fibers, or hair that may be wrapped around the brush-roll.
- Check connection between handheld vacuum and wand for blockages; clear blockages if required. If the issue persists, please contact Customer Service.
- Check clog access in wand for any blockages and clear any debris.

**Vacuum lifts area rugs.**

- Make sure you are not engaging boost mode. Take care when vacuuming area rugs or rugs with delicately sewn edges.
- Turn off the unit to disengage the brush-roll and restart with the power/selector switch.

**Brush-roll does not spin.**

- Immediately turn off the vacuum. Remove any blockages before turning the vacuum back on. Make sure the handheld vacuum is tilted back far enough for the brush-roll to engage. If the brush-roll still does not spin, please contact Customer Service.
- If the floor nozzle has headlights and they are not illuminated, there is a connection issue between the handheld vacuum, wand, and nozzle. Try disconnecting and reattaching the pieces. If the headlights still do not illuminate, please contact Customer Service.

**Vacuum turns off on its own.**

There are several possible reasons for the vacuum turning off on its own, including blockages, battery issues, and overheating. If vacuum turns off on its own, perform the following steps:

1. Turn on the vacuum and check the battery indicator lights located on the handheld portion of the vacuum. If recharging is needed, plug in while vacuum is in the off position.
2. Empty dust cup and clean filters (See **Emptying the Dust Cup** and **Cleaning the Filters** sections).
3. Check wand, accessories, and inlet openings and remove any blockages.
4. Allow unit and battery to cool for at least 45 minutes, until they return to room temperature.
5. Restart with power/selector switch.

**NOTE:** If vacuum still does not operate properly, contact Customer Service.

**Battery Indicator Lights on handheld vacuum are flashing.**

- Bottom LED light is flashing (Fig. A): Battery needs to be charged.
- Top and bottom LED lights are flashing (Fig. B): Battery temperature is not optimal, so charging is temporarily paused. Leave battery plugged in and charging will resume soon.
- If top 2 or bottom 2 LED lights are flashing (Fig. C, Fig. D), call Customer Service.



Fig. A

Fig. B

Fig. C

Fig. D

## ADDITIONAL ACCESSORIES AVAILABLE ON SHARK® ACCESSORIES.EU

- A** 8" Crevice Tool
- B** 12" Crevice Tool
- C** 18" Flexi Crevice Tool
- D** Flexible Hose
- E** Duster Crevice Tool
- F** Dusting Brush
- G** Multi-Angle Dusting Brush
- H** Anti-Allergen Dust Brush
- I** Upholstery Tool
- J** Wide Upholstery Tool
- K** Pet Multi-Tool
- L** Motorised Pet Tool
- M** Flexology® Under-Appliance Wand
- N** Home & Car Detail Kit
- O** Precision Duster
- P** Onboard Tool Clip
- Q** Accessory Bag
- R** Lithium Ion Battery
- S** Lithium Ion Power Pack Charger
- T** Charging Cord

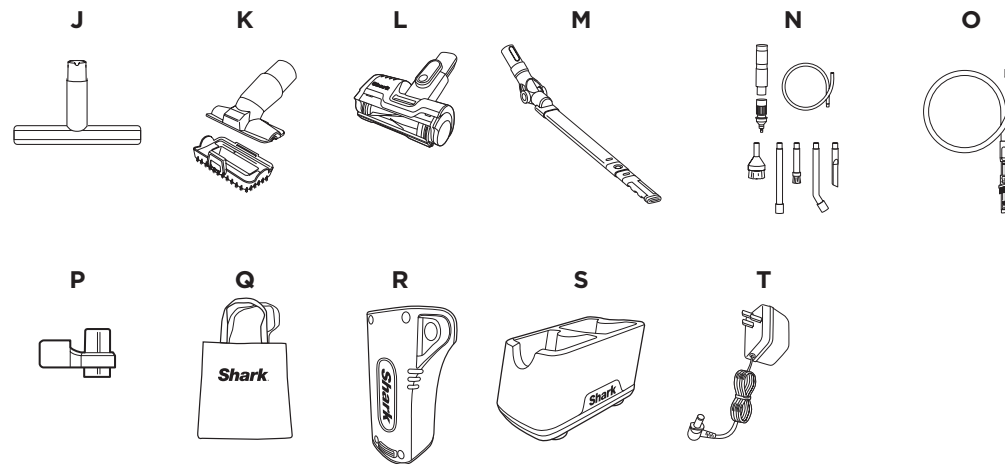
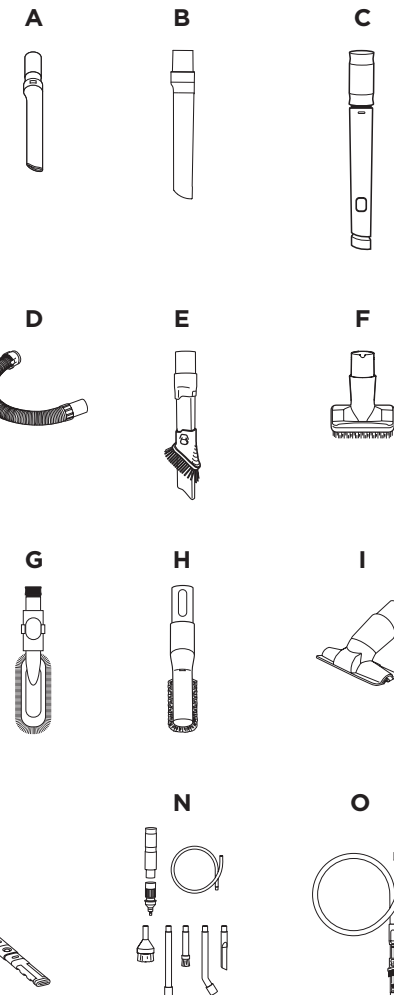

**NOTE:** Not all accessories come with all units. Please see the enclosed Quick Start Guide for your unit's configuration. To order additional accessories, visit [sharkaccessories.com](http://sharkaccessories.com).

## FIVE (5) YEAR LIMITED GUARANTEE

When a consumer buys a product in the UK, they get the benefit of legal rights relating to the quality of the product (your "statutory rights"). You can enforce these rights against your retailer. However, at Shark we are so confident about the quality of our products that we give the original product owner an additional manufacturer's guarantee of up to five years. (1 year as standard plus 4 years when you register) These terms and conditions relate to our manufacturer's guarantee only - your statutory rights are unaffected. Please note that the 5 year guarantee is available in all EU countries and in the UK if it stops being an EU country during the guarantee term.

The conditions below describe the prerequisites and scope of our guarantee. They do not affect your statutory rights or the obligations of your retailer and your contract with them.

The lithium ion power pack is not covered by the 5 year guarantee (see battery guarantee on next page)

### Shark® Guarantees

A household appliance like a vacuum cleaner constitutes a sizeable investment. Your new machine needs to work properly for as long as possible. The guarantee it comes with is an important consideration - and reflects how much confidence the manufacturer has in its product and manufacturing quality.

Every Shark machine comes with a free parts and labour guarantee. Our customer service helpline (0800 862 0453) is open from 9.00am to 6.00pm Monday - Friday. It's free to call, and you'll be put straight through to a Shark representative. You'll also find online support at [www.sharkclean.co.uk/uk](http://www.sharkclean.co.uk/uk).

### How do I register my extended Shark® guarantee?

You can register your guarantee online within 28 days of purchase. To save time, you'll need the following information about your machine:

- Date you purchased the machine (receipt or delivery note)
- To register online, please visit [www.sharkclean.co.uk/uk/register-guarantee](http://www.sharkclean.co.uk/uk/register-guarantee)

### IMPORTANT

- Both the 12 months and the extended 4 years guarantee will only cover your product from the date of purchase.
- Please keep your receipt at all times. Should you need to use your extended guarantee we will need your receipt to verify the information you have supplied to us is correct. The inability to produce a valid receipt may invalidate your guarantee.

### What are the benefits of registering my free Shark guarantee?

When you register your guarantee we'll have your details to hand if we ever need to get in touch. If you further agree to receive communications from us, you can also receive tips and advice on how to get the best out of your Shark vacuum and hear the latest news about new Shark technology and launches.

If you register your guarantee online, you'll get instant confirmation that we've received your details.

### How long are new Shark® machines guaranteed for?

Our confidence in our design and quality control means that your new Shark vacuum cleaner is guaranteed for a total of up to five years for the original owner (12 months plus an extended guarantee of 4 years).

What is covered by the free Shark guarantee?

Repair or replacement of your Shark machine (at Shark's discretion), including all parts and labour. A Shark guarantee is in addition to your legal rights as a consumer.

### What is not covered by the free Shark® guarantee?

1. Blockages - For details of how to unblock your vacuum cleaner, please refer to the Operating Manual.
2. Normal wear and tear such as brush bar, fuse, belt, batteries, hose etc.
3. Accidental damage, faults caused by negligent use or care, misuse, neglect, careless operation or handling of the vacuum cleaner which is not in accordance with the Shark Operating Manual supplied with your machine.
4. Use of the vacuum cleaner for anything other than normal domestic household purposes.
5. Use of parts not assembled or installed in accordance with the operating instructions.
6. Use of parts and accessories which are not Shark Genuine Components.
7. Faulty installation (except where installed by Shark).
8. Repairs or alterations carried out by parties other than Shark or its agents.
9. The Lithium ION power pack battery. Please see next page for battery guarantee.
10. Claims for repairs made under the extended manufacturer's guarantee by anyone other than the original owner who registered the product.

### What happens when my guarantee runs out?

Shark does not design products to last for a limited time. We do appreciate that there may be a desire for our customers to want to repair their vacuum cleaners after the guarantee has elapsed or the product has been sold to a new owner. In this case please contact our free phone customer service help line and ask about our out of guarantee program, on 0800 862 0453.

### Where can I buy genuine Shark® spares and accessories?

Shark spares and accessories are developed by the same engineers who developed your Shark vacuum. You'll find a full range of Shark spares, replacement parts and accessories for all Shark machines at [www.sharkclean.co.uk](http://www.sharkclean.co.uk).

Please remember that using non-Shark spares invalidates your guarantee.

## TWO (2) YEAR LIMITED BATTERY GUARANTEE

When a consumer buys a product in the UK, they get the benefit of legal rights relating to the quality of the product (your "statutory rights"). You can enforce these rights against your retailer. However, at Shark we are so confident about the quality of our products that we give the original product owner an additional manufacturer's guarantee of up to two years. (1 year as standard plus 1 year when you register) These terms and conditions relate to our manufacturer's guarantee only - your statutory rights are unaffected. Please note that the 2 year guarantee is available in all EU countries and in the UK if it stops being an EU country during the guarantee term.

The conditions below describe the prerequisites and scope of our guarantee. They do not affect your statutory rights or the obligations of your retailer and your contract with them.

### Shark® Guarantees

A household appliance like a vacuum cleaner constitutes a sizeable investment. Your new machine needs to work properly for as long as possible. The guarantee it comes with is an important consideration - and reflects how much confidence the manufacturer has in its product and manufacturing quality.

Every Shark machine comes with a free parts and labour guarantee. Our customer service helpline is 0800 862 0453. It's free to call, and you'll be put straight through to a Shark representative. You'll also find online support at [www.sharkclean.co.uk/uk](http://www.sharkclean.co.uk/uk).

### How do I register my extended Shark® guarantee?

You can register your guarantee online within 28 days of purchase. To save time, you'll need the following information about your machine:

- Date you purchased the machine (receipt or delivery note)
- To register online, please visit [www.sharkclean.co.uk/uk/register-guarantee](http://www.sharkclean.co.uk/uk/register-guarantee)

### IMPORTANT

- Both the 12 months and the extended 1 year guarantee will only cover your product from the date of purchase.
- Please keep your receipt at all times. Should you need to use your extended guarantee we will need your receipt to verify the information you have supplied to us is correct. The inability to produce a valid receipt may invalidate your guarantee.

### What are the benefits of registering my free Shark® guarantee?

When you register your guarantee we'll have your details to hand if we ever need to get in touch. If you further agree to receive communications from us, you can also receive tips and advice on how to get the best out of your Shark vacuum and hear the latest news about new Shark technology and launches.

If you register your guarantee online, you'll get instant confirmation that we've received your details.

### How long are new Shark® machines guaranteed for?

Our confidence in our design and quality control means that your new Shark® vacuum cleaner is guaranteed for a total of up to two years for the original owner (12 months plus an extended guarantee of 1 year).

What is covered by the free Shark guarantee?

Repair or replacement of your Shark machine (at Shark's discretion), including all parts and labour. A Shark guarantee is in addition to your legal rights as a consumer.

### What is not covered by the free Shark® guarantee?

1. Normal wear and tear.
2. Accidental damage, faults caused by negligent use or care, misuse, neglect, careless operation or handling of the vacuum cleaner which is not in accordance with the Shark Operating Manual supplied with your machine.
3. Use of the vacuum cleaner for anything other than normal domestic household purposes.
4. Faults caused by use of parts not assembled or installed in accordance with the operating instructions.
5. Faults caused by use of parts and accessories which are not Shark Genuine Components.
6. Faulty installation (except where installed by Shark).
7. Repairs or alterations carried out by parties other than Shark or its agents.
8. Claims for repairs made under the extended manufacturer's guarantee by anyone other than the original owner who registered the product.

### What happens when my guarantee runs out?

Shark does not design products to last for a limited time. We do appreciate that there may be a desire for our customers to want to repair their vacuum cleaners after the guarantee has elapsed or the product has been sold to a new owner. In this case please contact our free phone customer service help line and ask about our out of guarantee program, on 0800 862 0453.

### Where can I buy genuine Shark® spares and accessories?

Shark spares and accessories are developed by the same engineers who developed your Shark vacuum. You'll find a full range of Shark spares, replacement parts and accessories for all Shark machines at [www.sharkclean.co.uk](http://www.sharkclean.co.uk).

Please remember that using non-Shark spares invalidates your guarantee.



**Euro-Pro Europe Limited**  
**3150 Century Way**  
**Thorpe Park**  
**Leeds**  
**LS15 8ZB**  
**0800 862 0453**  
**sharkclean.co.uk**

Illustrations may differ from actual product. We are constantly striving to improve our products; therefore the specifications contained herein are subject to change without notice.

© 2020 SharkNinja Operating LLC. DUOCLEAN, FLEXOLOGY and SHARK are registered trademarks of SharkNinja Operating LLC.

I2201UK\_I2251UK\_Series\_IB\_E\_MP\_200709\_Mv1  
PRINTED IN CHINA

 **@sharkcleaninguk**

 **@sharkcleanuk**

 **@sharkcleanuk**