



DeLonghi

icona

Get Started



This short guide is not intended to explain all the functions of the appliance. Please read all the owner's instruction booklet before use.



ECO310

WELCOME

Introducing the exclusive world of espresso through the global leaders, De'Longhi. Based in Treviso, Italy, we grew up appreciating the taste and aroma of a good cup of coffee.

The De'Longhi Pump Espresso machine delivers freshly brewed espresso simply in a few steps. Enjoy your favorite cappuccino, lattes or your favorite beverage in your home.

Discover the unique story of design, passion and technology which made De'Longhi the world leader in the creation of espresso machines.



ESPRESSO DRINKS



Espresso

A small 1 or 2 oz. shot of pressure brewed espresso using approximately 1 Tbsp. of finely ground coffee.



Cappuccino

A single espresso shot topped with equal parts steamed and frothed milk (in a ratio of 1:1:1) served in a 4 to 6 ounce cup.



Café Latte

A double espresso shot topped with steamed milk to fill; a ratio of 2:1 of milk to espresso is typical.



Caffee' Mocha

This drink is based on layers of chocolate, milk, espresso and cream. Ingredients in a glass, prepare hot, frothed milk, let it cool. Pour the chocolate sauce into a different glass, carefully pour the milk. Slowly add the espresso. Top off with whipped cream and garnish with chocolate flakes.

Ingredients: 1 oz. of espresso coffee
4 oz. of hot milk
1 – 2 tablespoons of cold chocolate sauce
Whipped cream
Chocolate flakes



Italian Macchiato

A single or double espresso topped with a dollop of heated milk and served in a traditional espresso cup.



Espresso Lungo

From 3 oz. up to 4 oz. of brewed espresso using finely ground coffee.



Americano

1/3 of espresso lungo and 2/3 of hot water.



Caramel Macchiato

A tasty variation of latte macchiato with the addition of caramel syrup
Ingredients. Pour the caramel syrup down the inside of the glass. Pour first the cold milk and then the whisked hot milk into the glass. Add the milk foam. Prepare the espresso and pour it into the glass. Add a bonnet of milk foam.

Ingredients: 1 oz. of espresso coffee
1 oz. of cold milk
5 oz. of hot milk
Caramel syrup

... more recipes at: coffeemakers.delonghi.us/coffee-recipes-0

IMPORTANT SAFEGUARDS

When using electrical appliances, basic safety precautions should always be followed, including the following:

- Read all instructions.
- Do not touch hot surfaces. Use handles and knobs.
- To protect against fire, electrical shock and personal injury, do not immerse cord, plug or appliance in water or other liquid.
- Never allow the appliance to be used by children.
- Unplug from the outlet when not in use and before cleaning. Allow to cool before fitting or taking off parts, and before cleaning the appliance.
- Do not operate with a damaged cord or plug, or after the appliance malfunctions, or has been damaged in any manner. Return the appliance to the nearest authorized service facility for examination, repair or adjustment.
- The use of accessory attachments or spare parts not recommended by the appliance manufacturer may result in fire, electrical shock or personal injury.
- Do not use outdoors.
- Do not let the cord hang over the edge of the table or counter, or touch hot surfaces.
- Do not place on or near a hot gas or electrical burner, or in a heated oven.
- Plug cord into the wall outlet. To disconnect, turn any control to “off”, then remove plug from wall outlet.
- Do not use the appliance for other than the intended use. This appliance is to be utilized for domestic use only. Any other use is to be considered improper and therefore, dangerous.

WARNING: To reduce the risk of fire or electric shock, do not remove the cover. No user serviceable parts inside. Repair should be done by authorized service personnel only!

SAVE THESE INSTRUCTIONS • THIS PRODUCT IS FOR HOUSEHOLD USE ONLY

SHORT CORD INSTRUCTIONS

- A short power cord is provided to reduce risks resulting from becoming entangled in or tripping over a longer cord.
- Longer, detachable power supply cords or extension cords are available and may be used if care is exercised in their use.
- If an extension cord is used, the marked electrical rating should be at least as great as the electrical rating of the appliance. If the appliance is provided with 3 - wire, grounding type cord, the extension should be a **GROUNDING TYPE 3 – WIRE CORD**. The longer cord should be arranged so that it will not drape over the counter-top or table top where it can be pulled on by children or tripped over.
- Your product is equipped with a polarized alternating current line plug (a plug having one blade wider than the other). This plug will fit into the power outlet only one way. This is a safety feature. If you are unable to insert the plug fully into the outlet, try reversing the plug. If the plug should still fail to fit, contact your electrician to replace your obsolete outlet. Do not defeat the safety purpose of the polarized plug.

CAREFULLY READ AND KEEP THESE INSTRUCTIONS!

- This machine is designed to “make espresso coffee” and “hot drinks”. Be careful to avoid scalding from the water and steam jets or by using the machine incorrectly.
- This appliance is for household use only. All other use is considered improper and consequently dangerous.
- The manufacturer is not liable for damage caused by improper, incorrect or unreasonable use of the appliance.
- During operation, do not touch the hot surfaces of the appliance. Use the knobs or handles.
- Do not touch the appliance with damp hands or feet.
- Do not allow children or unfit persons to use the appliance unsupervised.
- Do not allow children to play with the appliance.
- In the event of breakdown or faulty operation, turn the appliance off and do not tamper with it. For repairs, contact a technical service center authorized by the manufacturer only. Request that only original spare parts be used. Failure to respect the above may compromise the safety of the appliance.

IN THE BOX

- A1. Cup warmer/storage tray
- A2. Cup tray bars
- A3. Control panel buttons
- A4. Tamper
- A5. Boiler outlet
- A6. Steam dial
- A7. Steam spout / frother coupling
- A8. Drip tray
- A9. Water tank

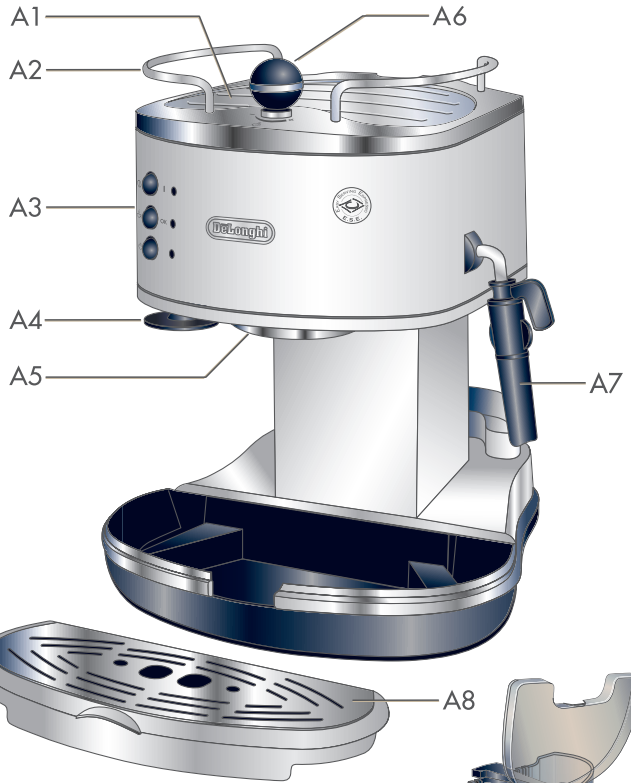

- B1. Filter holder with 2 filter cups
- B2. Measuring scoop



Get Started &
Owner's Instructions
Booklets

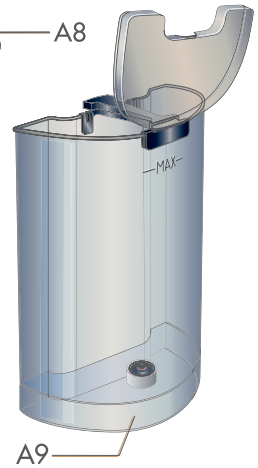

MACHINE SET UP



1 Remove tank, fill with water and replace.

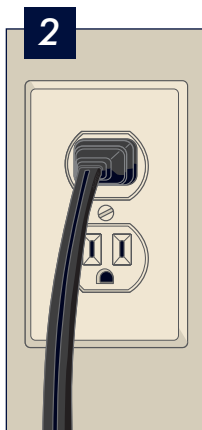

3 Place cup under boiler.



4 Press ON  button, unit is heating up.



5 When OK light is green, push  button.



6 Wait until water is delivered, then press  button to stop the flow.

Machine is now ready to work!

5 Note: This operation can take a few minutes. The machine may vibrate.

BREWING ESPRESSO Using Pre-Ground Espresso



1
Use correct filter, base on one or two cup.

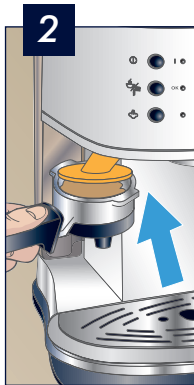

2
Tamp the coffee.

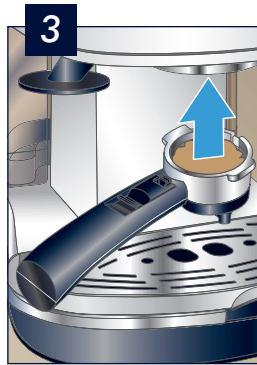

3
Attach filter holder in place into boiler outlet.

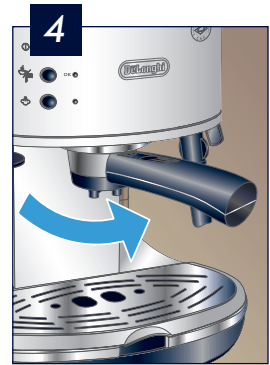

4
Turn right to lock into position.





5A
1
CUP
▼



5B
2
CUPS
▼



6
When OK light is green, push  button to start coffee delivery. And when the desired amount is reached, push  to stop.



7A



7B

Brew 1 or 2 Espresso at one time.

BREWING ESPRESSO Using E.S.E. POD Espresso



1 Use one cup filter.



2 Tamp the POD into the filter.

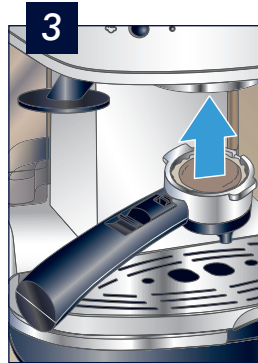

3 Attach filter holder in place into boiler outlet.



4 Turn right to lock into position.



5 When OK light is green, push  button to start coffee delivery. When the desired amount is reached, push again to stop.

E.S.E. (which stands for Easy Serving Espresso) is the technology being used to simplify the preparation of a good espresso using just a few simple actions, thanks to the adoption of the "serving" (individual pre-packed doses containing 7 grams of ground coffee that has been pressed and hermetically sealed between two fine layers of filter paper).



BREWING CAPPUCCINO or LATTE

Refer to previous section BREWING ESPRESSO for the espresso related part.

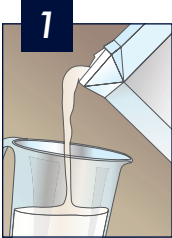

1
Fill 1/3 of the pitcher, 3.5 oz. for Cappuccino, 6 oz. for Latte.



2
Push  button.



3
Wait for OK light to turn green.

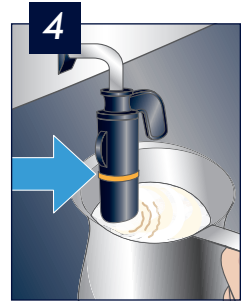

4
Be sure frother is immersed in milk, but not beyond the highlighted mark on the spout



5
Turn the steam dial to the desired level of foam and hold carafe in position.

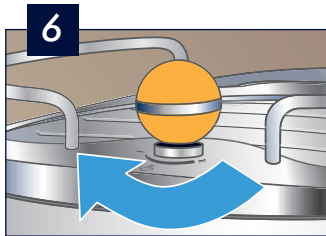

6
Prepare the coffee as described in the previous sections. Brew in a larger cup.







Tip for the BEST CAPPUCCINO:

Use Skim or 2% Milk at Refrigerator Temperature (about 41F/5C)

7
Pour the milk over the espresso and enjoy!

DELIVERING HOT WATER

Delivering hot water

1. Place a container under the spout (as close as possible to avoid splashes).
2. Push on  button and wait until OK light turns green.
3. Push on  button and turn the steam dial to the  position. Water runs out of the spout.
4. Close the steam dial and press the  button when the desired amount of water has been delivered.



Important! Danger of burns.

Never leave the machine unsupervised while delivering hot water or steam. The spout becomes hot during delivery. Hold by the handle only.

CLEANING and MAINTENANCE: FILTER



1 Remove steel filter cup from the steel filter holder.

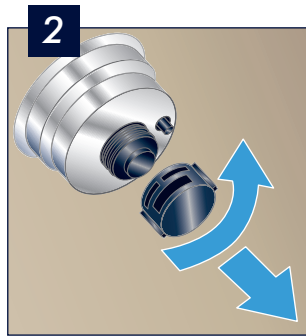

2 Unscrew cap from the steel filter cup.

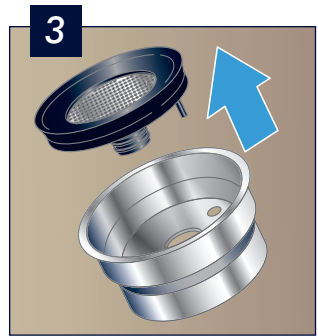

3 Remove gasket from the steel filter cup.



4 Remove the filter from the the gasket.

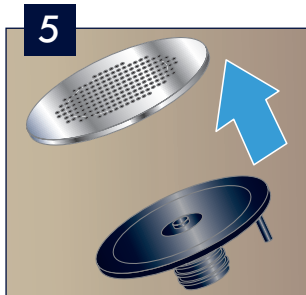

5 Remove the stainless-steel filter off the plastic disc.



6 Clean steel filter with a brush and the holes with a needle.

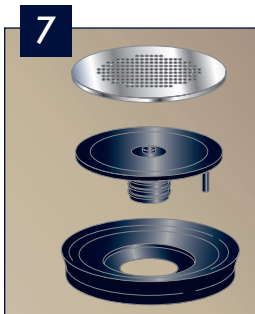

7 Replace the filter and plastic disc into the gasket. Make sure to insert the pin on the plastic disc into the hole in the gasket.

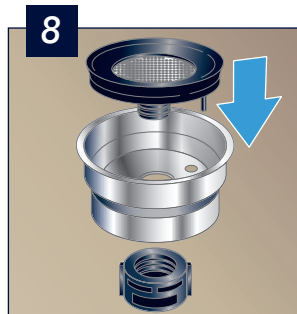

8 Replace the assembly in the steel filter cup, making sure the pin is inserted in the hole in the support. Finally, screw on the cap.

Note: If the filter is not cleaned and assembled properly, it could effect the crema of the espresso. The filter assembly must be cleaned (every 200 coffees.)

CLEANING and MAINTENANCE: FROTHER

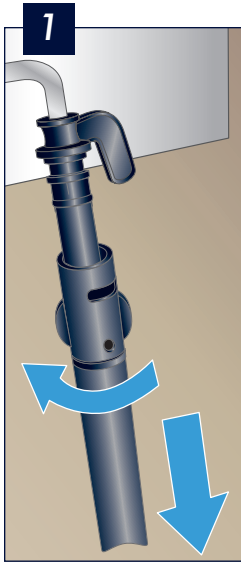

Unscrew the frother by rotating clockwise and pulling downwards.

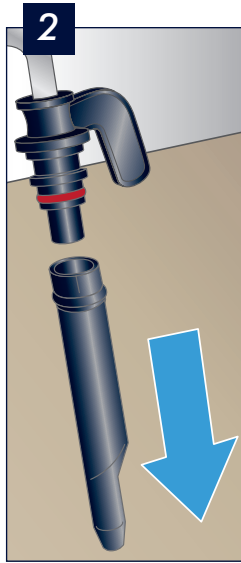

Remove the nozzle from the steam tube by pulling it downwards.

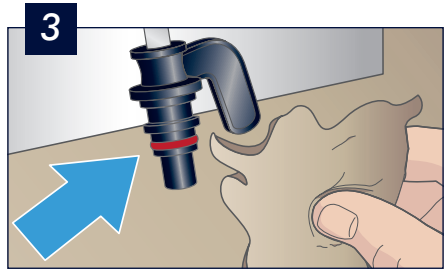

Thoroughly clean steam nozzle with cloth and warm water.

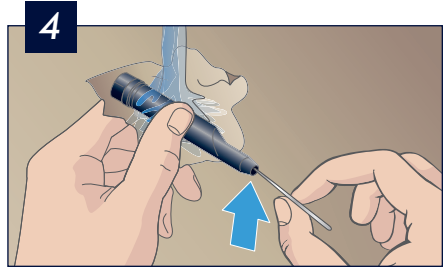

Clean nozzle with warm running water and use a needle to clean the hole.

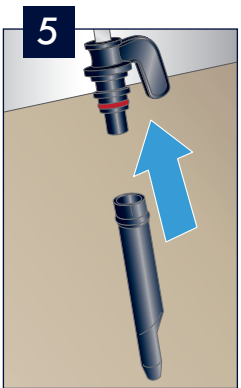

Replace the nozzle by inserting it onto the steam tube.

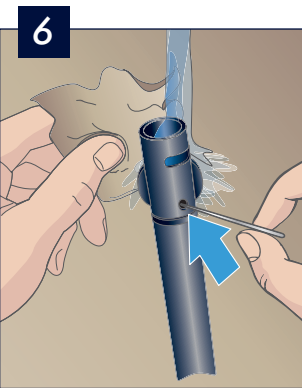

Clean frother with warm running water and use a needle to clean the hole.

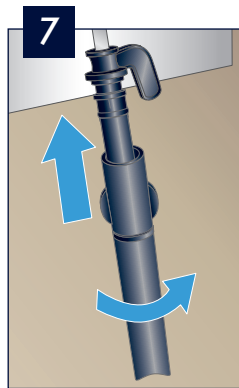

Replace the frother by inserting and rotating counterclockwise.

Both the frother and nozzle parts can be cleaned thoroughly by using De'Longhi Milk Clean.



CLEANING and MAINTENANCE: DESCALING

Descaling

You must descale the coffee machine about every 200 coffees.

Important! Descaler contains acids which may irritate the skin and eyes. It is vital to respect the manufacturer's safety warnings given on the descaler pack and the warnings relating to the procedure to follow in the event of contact with the skin and eyes.

NOTE: Failure to descale the appliance as described above voids the guarantee.

1. Turn the machine on.
2. Completely empty the water tank (A) and remove the water filter (if present).
3. Pour the descaler (B) and water (C) into the tank, according to the manual instructions.
4. Place an empty container (D) with a minimum capacity of 50 oz under the hot water spout and boiler outlet.
5. When OK light is green, press  button. Solution will come out from the boiler outlet.
6. Turn the steam dial to allow solution to come out from the frother spout. Turn off steam dial and push  button. Let unit rest for 15 minutes.



Important!

- Descaler contains acids which may irritate the skin and eyes. It is vital to respect the manufacturer's safety warnings given on the descaler pack and the warnings relating to the procedure to follow in the event of contact with the skin and eyes. Use De'Longhi descaler only. Under no circumstances should you use sulphamic or acetic based descalers. Their use invalidates the guarantee. Failure to descale the appliance as described also invalidates the guarantee.

Important! Danger of Burns

Hot water containing acid flows from the spout. Avoid contact with splashes of water.

7. Repeat steps 5 and 6 until water tank is empty (don't wait 15 minutes between steps).
8. To eliminate the solution and lime scale residues, rinse the tank and fill it with fresh water (without descaler); empty the containers and place them under the boiler outlet and hot water spout.
9. Press  button until water tank is empty.
10. Repeat steps 8 and 9.

The appliance is now ready for use.

Repairs to the coffee machine relative to lime scale problems are not covered by the warranty if the descaling procedure described above is not performed on a regular basis.

How to brew the Perfect CAPPUCCINO

Frothing the Milk

Fill a milk pitcher 1/3 of the way (a stainless steel pitcher will give you the best results) with milk. Submerge the frothing wand in the milk and turn the machine to steam function. Simply hold the pitcher in place and the wand will create rich, frothy cappuccino milk without moving the pitcher. As a guide, when the pitcher begins to get too hot to hold, that's a good sign that your milk has reached the right temperature.

Keep in mind, the authentic cappuccino temperature is lower than than the temperature of the milk drinks usually served at coffee shops. This is to preserve the nutritious elements of milk and enhance the taste of the drink.

Tips for the Perfect Froth

While you can use any type of milk with your machine, traditional cow's milk is recommended for the best results. The fat content will help determine final resulting foam. Whatever milk you choose, keep it cold until it's time to steam.

Whole Milk	Very Rich, Heavy Froth
2% Milk	Rich, Creamy Froth
1% Milk	Rich, Lighter Froth
Non-Fat Milk	Light Foam



How to brew the Perfect ESPRESSO

The Perfect Grind

It is best to grind just before you brew for freshness and the most flavor, as once the bean is ground it begins to lose its best flavor quickly. A burr grinder gives you the most even grind which leads to the most uniform espresso extraction, and best experience. Cleaning your grinder and machine regularly will help ensure you're always getting the best taste and performance. If your espresso is flowing too quickly and you aren't getting the rich crema, your grind may be too fine. If your espresso is coming out too slowly, your grind may be too coarse. Typically the ideal espresso grind should be the same consistency as a fine sand.



The Perfect Tamping

Use 1 scoop of grinds per espresso. **1 shot = 1 scoop, 2 shots = 2 scoops.** Make sure you never overfill your filter.

Distribute the grounds evenly around the basket. Lay the filter basket on a flat surface, like a table, and tamp with an even, medium amount of pressure.

The Perfect Brew

If you prefer a stronger espresso, you can stop the shot sooner for a more concentrated brew. If you tend to like your brew more mild, you can let your shot run a little longer.

Espresso Temperature

The perfect temperature of espresso is lower than the typical filter coffee. Keeping up with the maintenance and descaling of your machine will help ensure that you're consistently brewing your espresso at the right temperature.

BEANS: Choosing and Storing your espresso beans

Types of Beans

There are seemingly dozens of varieties of coffee beans to choose from, but really, there are just 2 categories to consider. These can be found alone or sometimes as a blend.

TYPE	TASTE	CAFFINE	QUALITIES	FLAVORS
Arabica	Sweet	Less Caffeine	More Acidity	Aromatic, Fruit, Berries
Robusta	Strong	More Caffeine	Creamier	Nutty, Chocolatey

Another characteristic of your coffee bean is the roast. While typically an espresso is made with a medium to dark roast, you can use any to suit your preference.

ROAST	COLOR	FLAVOR
Light	Light Brown	Mild
Medium	Medium Brown	Stronger
Medium – Dark	Rich, Dark Color	Bittersweet
Dark Roast	Shiny, Black	Pronounced Bitterness

Tip: The highest quality, whole bean coffee, is sold in flexible, laminated packages, with a small one way valve located on the package. This valve is where the air is removed from the package, giving the bag an irregular surface. This container preserves the beans the best and the longest, up to 2 years (if unopened).

Whatever your choice, remember, Espresso is a drink, not a roasting level or type of bean. You can make an espresso with any type of coffee bean.

How to Store

It's best to keep your coffee, either whole bean or already ground, in an airtight container in a cabinet or dark cool area. Never freeze your coffee. It's important to keep you coffee away from air, moisture, heat and light to preserve it's freshness.



If you have any questions, your local coffee shop barista can be a great resource.

TROUBLESHOOTING

PROBLEM	SOLUTION
No crema	<ol style="list-style-type: none">1. The filter is clogged or not assembled correctly. See maintenance page.2. The coffee ground is too coarse or not tamped enough.
Doesn't deliver coffee	<ol style="list-style-type: none">1. The "OK" light is not on.2. The filter is clogged. Try a different one and/or clean it. See maintenance page.3. The boiler outlet is clogged. Clean follow manual.4. There is not water in the tank.5. Dial Is not in the "delivery" position.6. Perform priming, see page 6.
Does leak from the filter holder on the back of the unit	<ol style="list-style-type: none">1. The filter holder is not tightened enough.2. The filter is clogged. Try a different one and/or clean it. See maintenance page.3. The boiler outlet is not assembled correctly or gasket is worn out. Clean follow manual.
Unit vibrates	<ol style="list-style-type: none">1. Be sure the unit is on a flat surface and the rubber feet are in place.2. It is normal for the pump to have a slight vibration while in operation. Especially during the first set up.3. The drip tray is not sitting correctly.
Coffee drips very slowly	<ol style="list-style-type: none">1. The coffee ground is tamped too much.2. The filter is clogged. Try a different one and/or clean it. See maintenance page.3. The boiler outlet is clogged. Clean follow manual.
Coffee not hot enough	<ol style="list-style-type: none">1. Espresso is typically not as hot as regular coffee because of a different extraction method.2. Descale the unit regularly; lime scale can affect the performance of the boiler.3. Use pre warmed cups.4. Run the unit without coffee first as rinse function which will help to heat the unit quickly and to warm the cups.
Unit doesn't froth	<ol style="list-style-type: none">1. Turn the dial to steam and wait the "OK" light goes on.2. Use milk at 1% fat at 41F.3. Don't immerse the wand completely into the milk (see the mark on the frother).4. Clean the wand exterior and interior piece, be sure the hole for the proper air inlet is not clogged.5. Move the pitcher slightly up and down and rotate in the pitcher to help to form the foam.

ACCESSORIES

Enjoy our full line of drinkware:
an exclusive line of Espresso, Cappuccino, Latte glasses and milk pitcher.



Care Kit Line

Experience the De'Longhi Care Kit Line to improve the performance of your fully automatic machine.



EcoDecalk



EcoDecalk mini



Water Filter



Coffee Care Kit



Milk Clean



... to learn more about the De'Longhi accessories visit: delonghi.com





Better Everyday

www.delonghi.com

 like us: DeLonghi North America –  follow us @DeLonghiNA