

Visite www.wincous.com para ver manuales en francés y español.
Visitez www.wincous.com pour les manuels en français et en espagnol.

winco® KATTEX™ FRUIT & VEGETABLE SLICER FVS-1



FVS-1 shown mounted on optional
CBM-1218 Cutting Board Mount
(sold separately)

Warranty Service
To initiate warranty service contact:
equipservice@wincous.com or call: 973-295-3899

DO NOT send unit to WINCO without first contacting
our customer service department.

For California Customers

 **WARNING:** Cancer and Reproductive Harm - www.P65Warnings.ca.gov

INTRODUCTION

Congratulations on the purchase of your KATTEX equipment. Please take the time to carefully read through this manual to ensure the equipment is operated and maintained properly, to ensure the best possible performance from this product for many years.

WINCO will not accept liability if:

- The instructions in this manual have not been followed correctly.
- Non-authorized personnel have tampered with the equipment.
- Non-original spare parts are used.
- The equipment has not been handled and cleaned correctly.
- There is any use damage to the unit.

SAFETY



WARNING: THE BLADES ARE VERY SHARP. PLEASE USE CAUTION WHEN HANDLING AND OPERATING THE EQUIPMENT AND KEEP HANDS AWAY FROM ALL CUTTING EDGES.



AVERTISSEMENT: TRÈS COUPANTES TRÈS COUPANTES. VEUILLEZ FAIRE PREUVE DE PRUDENCE LORSQUE VOUS MANIPULEZ ET UTILISEZ LA MACHINE ET GARDEZ LES MAINS ÉLOIGNÉES DE TOUS LES BORDS DE COUPE.



WARNING: IMPROPER INSTALLATION, ADJUSTMENT, ALTERATION, SERVICE OR MAINTENANCE CAN CAUSE PROPERTY DAMAGE, INJURY, OR DEATH. READ THE INSTALLATION, OPERATION, AND MAINTENANCE INSTRUCTIONS THOROUGHLY BEFORE INSTALLING OR SERVICING THIS EQUIPMENT.



AVERTISSEMENT: TOUTE INSTALLATION, RÉGLAGE, MODIFICATION, RÉPARATION OU ENTRETIEN INCORRECT PEUT OCCASIONNER DES DOMMAGES MATÉRIELS, DES BLESSURES GRAVES OU LA MORT. LIRE LES INTRUCTIONS D'INSTALLATION, D'UTILISATION ET D'ENTRETIEN ATTENTIVEMENT AVANT D'INSTALLER OU DE RÉPARER CET APPAREIL.



CAUTION: THESE MODELS ARE DESIGNED, BUILT, AND SOLD FOR COMMERCIAL USE ONLY. IF THESE MODELS ARE POSITIONED SO THE GENERAL PUBLIC CAN USE THE EQUIPMENT, MAKE SURE THAT CAUTION SIGNS, WARNINGS, AND OPERATING INSTRUCTIONS ARE CLEARLY POSTED NEAR EACH UNIT SO THAT ANYONE USING THE EQUIPMENT WILL USE IT CORRECTLY AND NOT INJURE THEMSELVES OR HARM THE EQUIPMENT.



ATTENTION: CES MODÈLES SONT CONÇUS, FABRIQUÉS, ET VENDUS POUR UN USAGE COMMERCIAL SEULEMENT. SI CES MODÈLES SONT PLACÉS POUR QUE LE GRAND PUBLIC PUISSE LES UTILISER, ASSUREZ-VOUS QUE LES CONSIGNES D'ATTENTION, D'AVERTISSEMENT, ET LES INSTRUCTIONS D'UTILISATION SOIENT CLAIREMENT AFFICHÉES PRÈS DE CHAQUE UNITÉ DE SORTE QUE N'IMPORTE QUEL UTILISATEUR DE L'APPAREIL L'EMPLOIE CORRECTEMENT ET NE SE BLESSE PAS OU N'ENDOMMAGE PAS L'APPAREIL.



WARNING: A FACTORY AUTHORIZED SERVICE PROVIDER SHOULD HANDLE ALL MAINTENANCE AND REPAIR. BEFORE DOING ANY MAINTENANCE OR REPAIR, FOLLOW SERVICE SET UP ARRANGEMENT.



AVERTISSEMENT: UN TECHNICIEN AUTORISÉ PAR L'USINE DEVRA EFFECTUER TOUT L'ENTRETIEN ET LES RÉPARATIONS. AVANT DE FAIRE TOUT ENTRETIEN OU RÉPARATION, VEUILLEZ CONTACTER WINCO.

SAFETY (CONT.)

To ensure safe installation and operation, please carefully read and understand the following statements.

Unless the operator is adequately trained and supervised there is a possibility of serious injury. Owners of this equipment bear the responsibility to make certain that this equipment is used properly and safely, and to strictly follow all of the instructions contained in this manual and the requirements of local, state or federal law.

Owners should not permit anyone to touch this equipment unless they are over 18 years old, are adequately trained and supervised, and have read and understood this manual.

Owners should also ensure that no customers, visitors or other unauthorized personnel come in contact with this equipment. It is the responsibility of the owner and the operator to remain alert to any hazards posed by the function of this equipment.

If there is ever uncertainty about a particular task or the proper method of operating this equipment, ask an experienced supervisor.

Note: Please remember that this manual and the warning labels do not replace the need to be alert, to properly train and supervise operators, and to use common sense when using this equipment.

PACKAGE CONTENTS

The KATTEX Fruit & Vegetable Slicer comes with the following:

- Fruit & Vegetable Slicer (partially assembled)
- Mounting Bracket and Leg Assembly
- Push Rod and Push Rod Spring
- Push Plate
- Hardware Bag
- Operating Instruction Manual

WINCO® prides itself on quality and service, ensuring that at the time of packing, all products are supplied fully functional and free of damage. Should you find any damage as result of freight, please contact your WINCO® dealer immediately.

UNPACKING THE EQUIPMENT

Dispose of all packaging materials in an environmentally responsible manner.

1. Remove all packing materials and tape, as well as any protective plastic and cardboard from the unit.
2. Clean any glue residue left over from the plastic or tape.
3. Place the unit in the desired position and height.

NOTE: SAVE THE ORIGINAL BOX AND PACKING TO USE WHEN REPACKAGING THE EQUIPMENT FOR SHIPPING IF SERVICES ARE NEEDED.

PREPARATION



WARNING: THE BLADES ARE VERY SHARP. PLEASE USE CAUTION WHEN HANDLING.

1. Remove the mounting locking screw and slide out leg from the mounting base.
2. Determine the location for the unit and place the mounting base on the work surface, countertop, or mounting board.
3. Mark the holes of the mounting base on the surface.
4. Drill 1/4" holes in the surface where the holes are marked.
5. Attach the mounting base to the work surface with the flat head screws provided.

Note: If work surface is thin, please use the provided hex nuts for extra security.

6. Attach the mounting leg to the fruit and vegetable slicer with hex screws.

Note: The locking pin should be in the 9 o'clock position on the fruit and vegetable slicer.

7. Slide the assembled fruit and vegetable slicer onto the mounting base and secure with the mounting locking screw.
8. Place the push plate inside fruit and vegetable slicer. Slide the push rod through the "L" bracket hole and through the spring and thread into the back of the push plate.

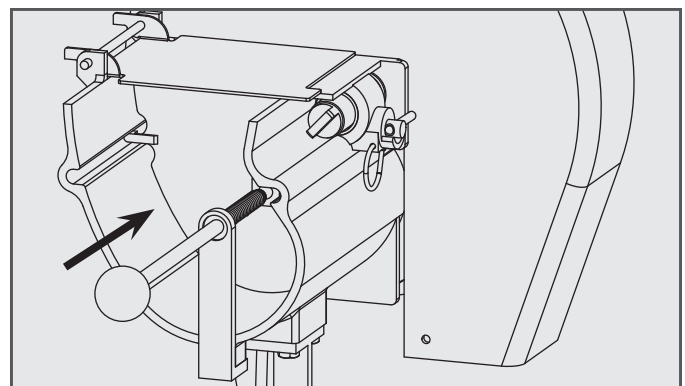
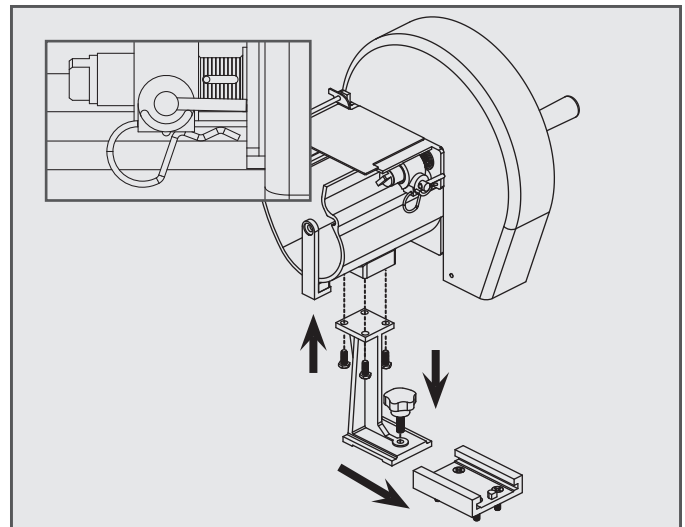
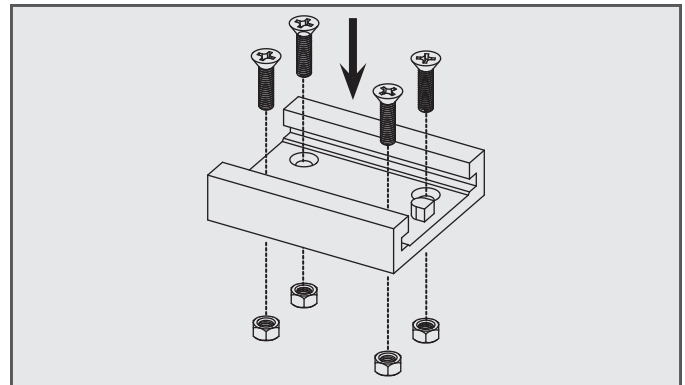
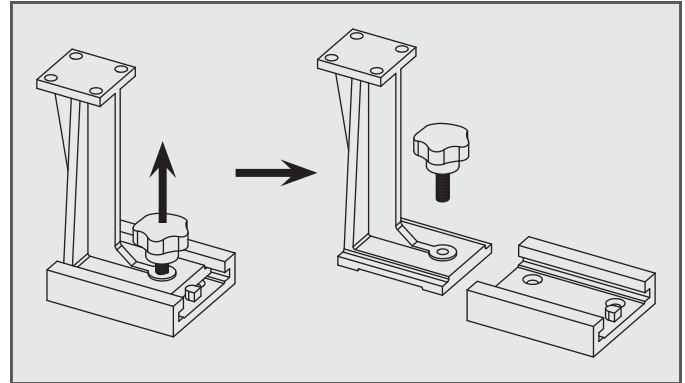

OPERATION

1. Check slice thickness setting and adjust if necessary.

The adjustable slicing unit is easily adjusted by holding the handle stationary and by turning the adjusting screw at the end of the adjusting shaft assembly.

The thickness of the slice is indicated by the alignment of the pin in the slot and the lines on the recessed portion of the main shaft.

These lines are 1/16" apart; therefore, 2 lines = 1/8", 3 lines = 3/16", and so on, up to 1/2".

2. Raise cover plate and place produce up to 5" in length into the trough. If necessary pull the push rod and push plate away from the slicer.
3. Close the cover plate and gently push on the push rod while turning the handle on the rotary cutting unit in a clockwise direction. Maintain uniform pressure on the push rod.

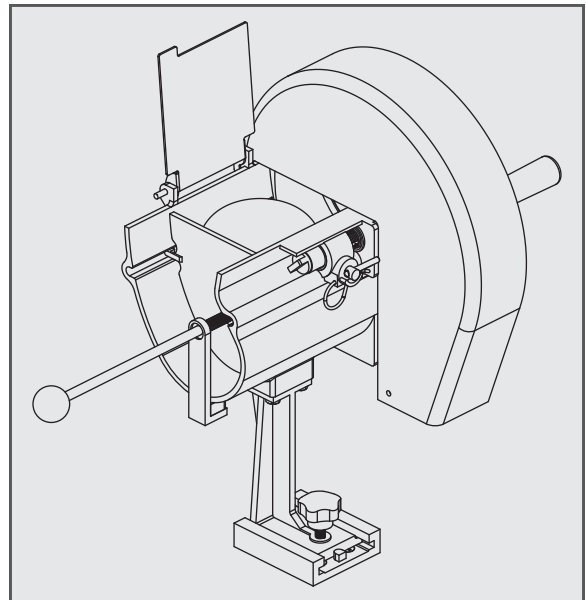
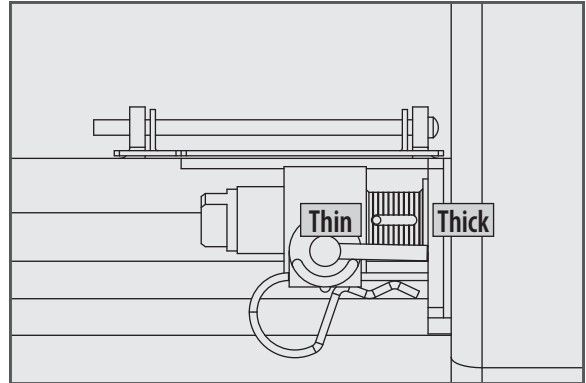

OPERATION TIPS

1. For slice uniformity, turn the rotary slicing unit slower as the slice width increases. This will help assure that the produce is fully aligned to the adjusting plate before the next blade begins to cut.
2. After placing produce in the trough, turn the handle about one-quarter turn counterclockwise before turning in the cutting direction. This will produce a "running start" as the blade makes its first cut. As a result it will be easier and will provide more uniform slices.
3. Do not apply heavy pressure on the push rod. It is unnecessary and will not improve the slicing or shredding action.
4. Do not force produce that is too large into the trough. It is recommended to use produce up to 5" in length. It will be difficult to push into the cutting blade and will result in uneven cuts.

CLEANING

Cleaning of the device is important to assure optimal performance and longevity. Minimize the use of alkaline or acidic cleaners, as they may cause pitting and dulling of the finish.

The Fruit & Vegetable Slicer can be washed as a fully-assembled unit by loosening the mounting locking screw and moving the unit to a sink or dishwasher.

1. Turn the locking pin counterclockwise from the 3 o'clock to the 9 o'clock and pull out the shaft and blade turntable assembly.



WARNING: THE BLADES ARE VERY SHARP. PLEASE USE CAUTION WHEN HANDLING.

Note: The shaft and blade turntable assembly can also be disassembled for additional cleaning or blade replacement, as required.

- a. Remove screw and slide out shaft and blade holder.
- b. Blades can also be removed by unscrewing the small screws.

2. Lift the guard off the trough.
3. To remove the cover plate, slide out the hinge pin.

Note: The hinge pin head should face the guard.

4. To remove the push rod and push plate, turn the push rod counterclockwise to unthread it from the push plate.
5. Remove the locking pin by pulling out the cotter pin.
6. Thoroughly wash/rinse/sanitize parts in warm soapy water, dry and carefully reassemble.

Note: Hand washing unit is recommended as washing in a commercial dishwasher will cause the all aluminum parts to darken over time, this is normal, and does not effect the general operation of the unit.

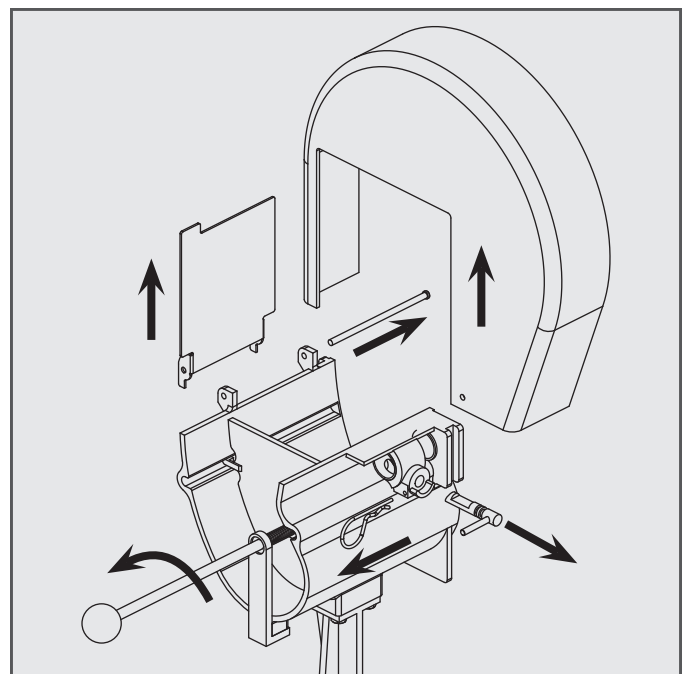
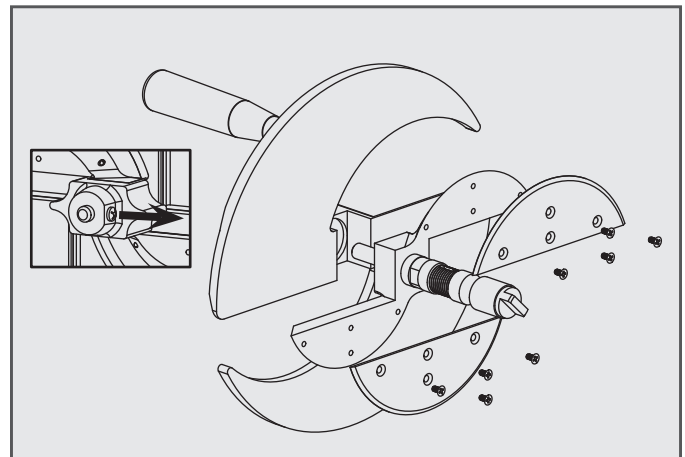
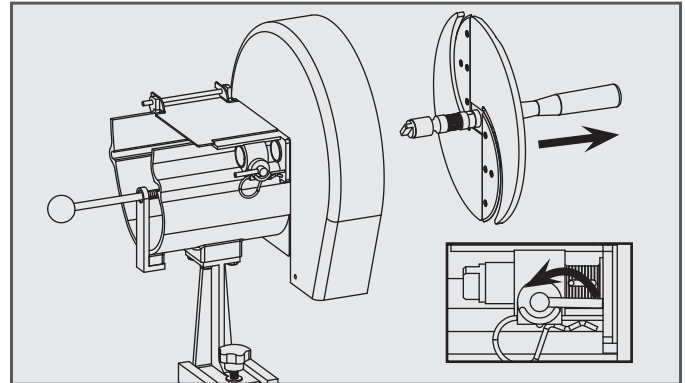

BLADE MAINTENANCE

To prolong the sharpness of the blades, they can be honed as follows:

1. Adjust the fruit and vegetable slicer to the maximum slice thickness.
2. Remove the shaft and blade turntable assembly. (Refer to cleaning instructions)
3. Use a fine honing stone (do not file) on the flat side of the blade, and, if needed, on the beveled side (be sure to maintain the original sharpening angles).

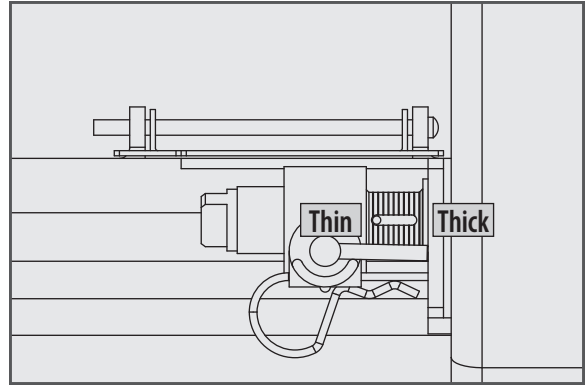

MAINTENANCE

As needed, lubricate the following places with mineral oil, food grade grease, or rub them with Paraffin. **DO NOT LUBRICATE WITH COOKING OIL.**

- push rod
- grooves in the trough
- plastic bearings in the trough
- slots in the adjustable slicer shaft

PARTS LIST

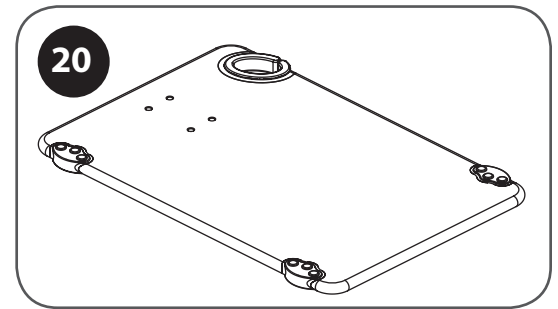
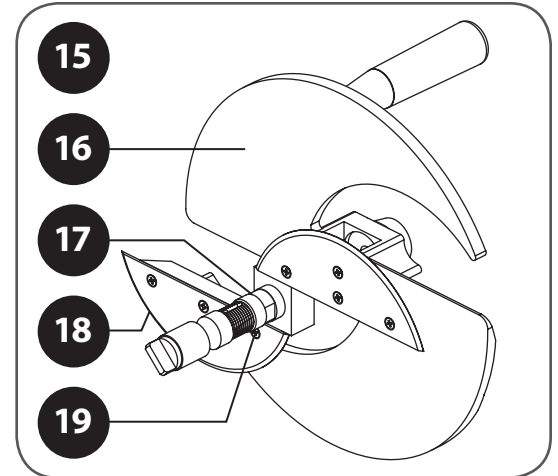
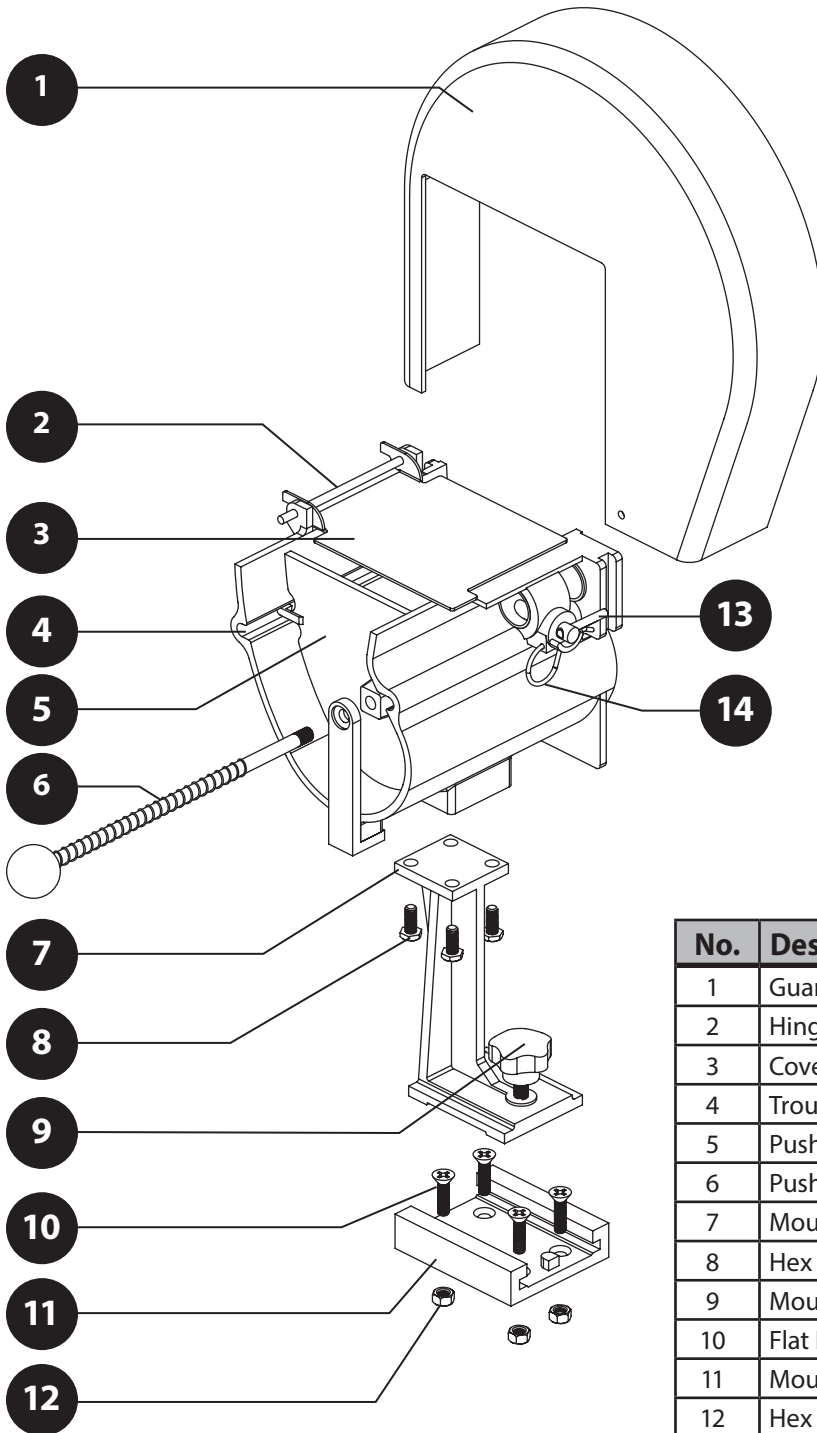

| No. | Description | Part # | QTY |
|-----|----------------------------------|----------|-----|
| 1 | Guard | FVS-P1 | 1 |
| 2 | Hinge Pin | FVS-P2 | 1 |
| 3 | Cover Plate | FVS-P3 | 1 |
| 4 | Trough | FVS-P4 | 1 |
| 5 | Push Plate | FVS-P5 | 1 |
| 6 | Push Rod & Spring | FVS-P6 | 1 |
| 7 | Mounting Leg | FVS-P7 | 1 |
| 8 | Hex Screws | FVS-P8 | 4 |
| 9 | Mounting Locking Screw | FVS-P9 | 1 |
| 10 | Flat Head Screws | FVS-P10 | 4 |
| 11 | Mounting Bracket | FVS-P11 | 1 |
| 12 | Hex Nuts | FVS-P12 | 4 |
| 13 | Locking Pin | FVS-P13 | 1 |
| 14 | Cotter Pin | FVS-P14 | 1 |
| 15 | Shaft & Blade Turntable Assembly | FVS-1SB | 1 |
| 16 | Turntable with Handle | FVS-P15 | 1 |
| 17 | Shaft with Blade Holder | FVS-P16 | 1 |
| 18 | Blades | FVS-1B | 2 |
| 19 | Blade Screws | FVS-P17 | 8 |
| 20 | Cutting Board Mount | CBM-1218 | 1 |

Contact factory for parts not listed

WARRANTY

NOTE: WARRANTY DOES NOT COVER THE PUSHER BLOCKS AND BLADE ASSEMBLY BLOCKS (PLUS PARTS).

WINCO warrants to the original purchaser of new equipment and non-electrical food preparation products (other than blades), when installed in accordance with our instructions within North America and subjected to normal use, is free from defects in material or workmanship for a period of 1 year. The labor warranty is one year from original installation or 18 months from actual factory shipment date, whichever date occurs first.

THIS WARRANTY IS IN LIEU OF ALL OTHER WARRANTIES, WHETHER EXPRESSED OR IMPLIED. WINCO EXPRESSLY DISCLAIMS ANY IMPLIED WARRANTY OF MERCHANTABILITY OR EXPRESSED OR IMPLIED WARRANTY OF FITNESS FOR A PARTICULAR PURPOSE.

WINCO'S OBLIGATION AND LIABILITY UNDER THIS WARRANTY IS EXPRESSLY LIMITED TO REPAIRING AND REPLACING EQUIPMENT THAT PROVES TO BE DEFECTIVE IN MATERIAL OR WORKMANSHIP WITHIN THE APPLICABLE WARRANTY PERIOD.

IN NO EVENT SHALL WINCO BE LIABLE FOR INCIDENTAL OR CONSEQUENTIAL DAMAGES TO BUYER OR ANY THIRD PARTY, INCLUDING, WITHOUT LIMITATION, LOSS OF PROPERTY, PERSONAL INJURY, LOSS OF BUSINESS OR PROFITS OR OTHER ECONOMIC LOSSES, OR STATUTORY OR EXEMPLARY DAMAGES, WHETHER IN NEGLIGENCE, WARRANTY, STRICT LIABILITY, OR OTHERWISE.

This warranty is given only to the first purchaser from a retail dealer. No warranty is given to subsequent transferees. Warranty does not cover product failures caused by: failure to maintain, neglect, abuse, damage due to excess water, fire, normal wear, improper set up and use. Periodic maintenance is not covered. This warranty is not in force until such time as a properly completed and digitally signed Installation/Warranty Registration has been received by WINCO within 30 days from the date of installation.

WARRANTY SERVICE

To initiate warranty service contact: equipservice@wincous.com or call: 973-295-3899

DO NOT send unit to WINCO® without first contacting our customer service department. Please provide or have the following information available:

- Model Number
- Date of Purchase
- Purchase Dealer
- Operator / Installation Contact Information
- Business Name & Business Address
- Contact Name & Contact Telephone Number

REGISTER ONLINE AT:

<http://www.wincous.com>

Proof of purchase is required to extend warranty more than 1 year from date of shipment from the factory.

THE FOREGOING WARRANTY PROVISIONS ARE A COMPLETE AND EXCLUSIVE STATEMENT BETWEEN THE BUYER AND SELLER. WINCO® NEITHER ASSUMES NOR AUTHORIZES ANY PERSONS TO ASSUME FOR IT ANY OTHER OBLIGATION OR LIABILITY IN CONNECTION WITH SAID EQUIPMENT.

Examples of items not covered under warranty, but not limited to just these items:

1. Acts of God, fire, water damage, burglary, accident, theft.
2. Freight damage.
3. Improper installation or alteration of equipment.
4. Use of generic or after-market parts.
5. Repairs made by anyone other than a WINCO® designated service provider.
6. Lubrication.
7. Expendable wear parts, adjustable feet, blown fuses, lamps, etc.
8. Cleaning of equipment.
9. Misuse or abuse.

Warranty voided if:

1. Product is altered by user
2. Serial number plate is removed
3. Product is installed in a prison or any correctional facility.

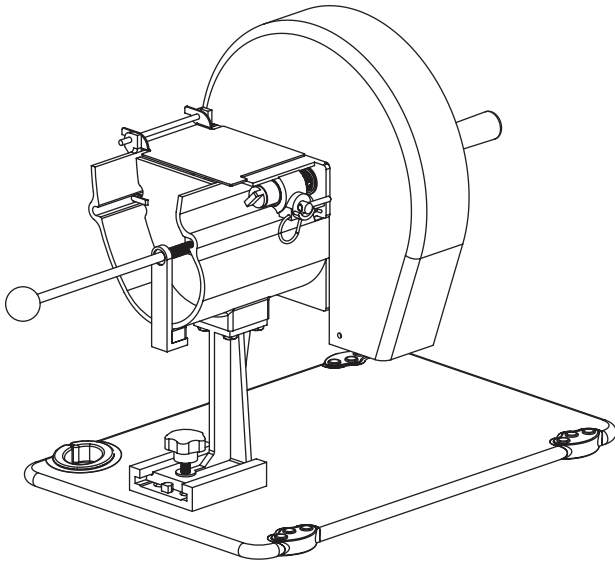

WARNING: THE BLADES ARE VERY SHARP. PLEASE USE CAUTION WHEN HANDLING.

1. Remove the mounting locking screw and slide out leg from the mounting base.
2. Attach the mounting base to the cutting board mount with the flat head screws and sleeve nuts provided with the cutting board mount.
3. Attach the mounting leg to the fruit and vegetable slicer with hex screws.

Note: The locking pin should be in the 9 o'clock position on the fruit and vegetable slicer.

4. Slide the assembled fruit and vegetable slicer onto the mounting base and secure with the mounting locking screw.
5. Place the push plate inside fruit and vegetable slicer. Slide the push rod through the "L" bracket hole and through the spring and thread into the back of the push plate.

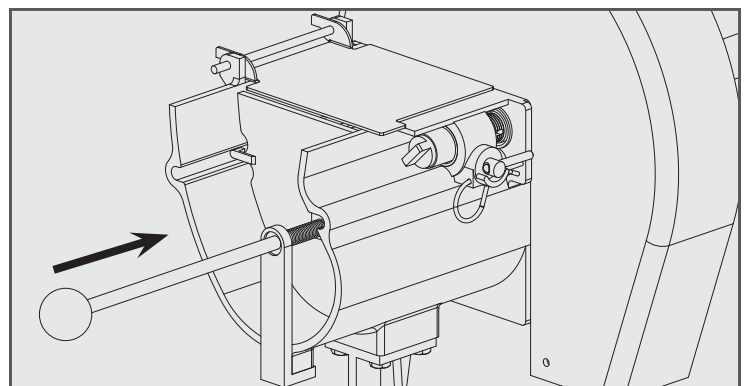
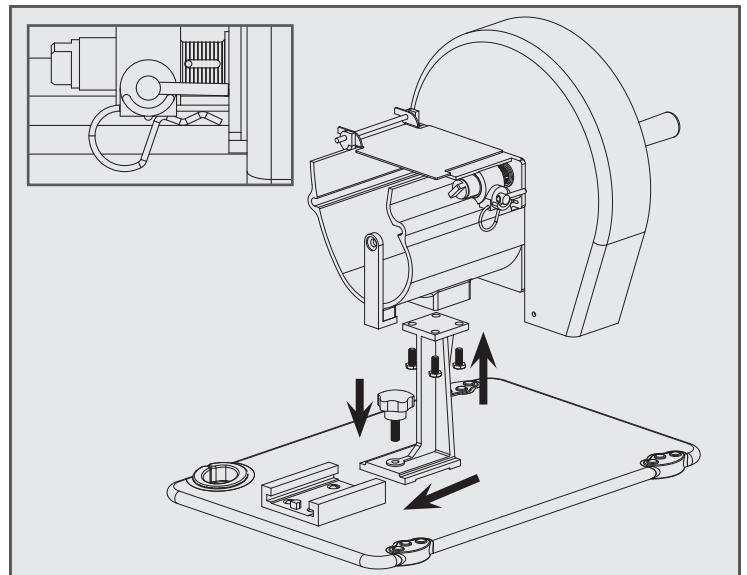
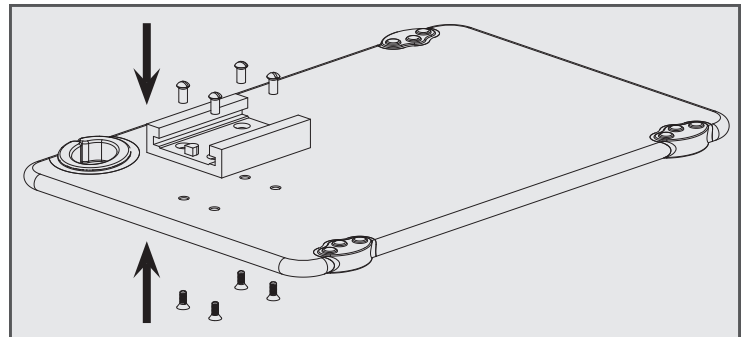
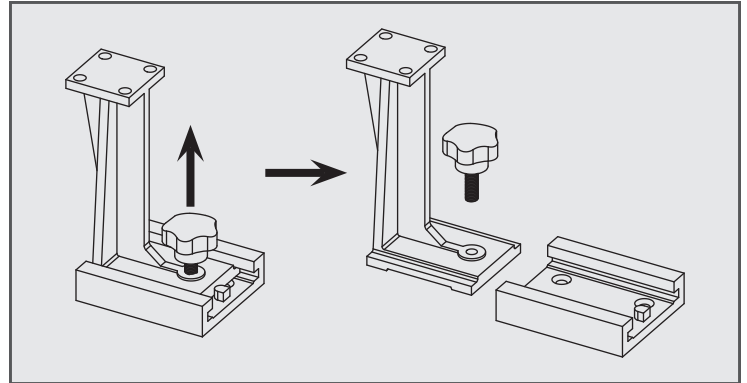

winco[®]
KATTEX[™]
FRUIT & VEGETABLE SLICER

