

13" Portable Planer with Helical-Style Cutterhead



Operator's Manual

Record the serial number and date of purchase in your manual for future reference.

The serial number can be found on the specification label on the rear of your machine.

Serial Number: _____ Date of purchase: _____

For technical support, email techsupport@rikontools.com - For parts questions, email parts@rikontools.com

TABLE OF CONTENTS

Specifications.....	2
Safety Instructions	3 - 6
Getting To Know Your Machine	7
Contents of Package	7 - 8
Installation	8
Assembly	9
Adjustments.....	10 - 11
Operation	12 - 13
Maintenance	14 - 16
Electricals & Wiring Diagram	5 & 16
Troubleshooting	17
Parts Diagrams & Parts Lists	18 - 21
Accessories	22
Notes	22
Warranty	23

SPECIFICATIONS - 25-135H

Motor	120V, 60Hz, 15A, PH1, AC
Motor Speed (no load).....	22,000 RPM
Cutterhead Diameter	2"
Cutterhead Speed	10,000 RPM
Number of HSS Inserts, 2-sided.....	26
Number of Cutterhead Insert Rows	6
HSS Inserts Size, 2-sided.....	14.2mm x 14.2mm x 2mm
Maximum Depth of Cut	1/8"
Maximum Cutting Width	13"
Maximum Cutting Depth (Height)	6"
Minimum Length of Stock	7"
Minimum Width of Stock	3/4"
Minimum Thickness of Stock	3/16"
Two Feed Speeds SF/min	16 & 26
Table Size (LxW)	9-7/16" x 13-1/16"
Extension Table (2) Sizes (LxW)	12" x 14"
Dust Port (O.D.).....	4" or 2-1/2" Diameter
Dust Collection Minimum CFM	650
Noise Level (no load)	≤ 100 dB
Overall Size (LxWxH).....	22" x 34-1/4" x 19-1/4"
Base Size (L xW).....	13-3/8" x 22"
Net Weight	68 lbs

NOTE: The specifications, photographs, drawings and information in this manual represent the current model when the manual was prepared. Changes and improvements may be made at any time, with no obligation on the part of RIKON POWER TOOLS®. to modify previously delivered units. Reasonable care has been taken to ensure that the information in this manual is correct, to provide you with the guidelines for the proper safety, assembly and operation of this machine.

SAFETY INSTRUCTIONS

IMPORTANT! Safety is the single most important consideration in the operation of this equipment. **The following instructions must be followed at all times.** Failure to follow all instructions listed below may result in electric shock, fire, and/or serious personal injury.

There are certain applications for which this tool was designed. We strongly recommend that this tool not be modified and/or used for any other application other than that for which it was designed. If you have any questions about its application, do not use the tool until you have contacted us and we have advised you.

SAFETY SYMBOLS



SAFETY ALERT SYMBOL: Indicates DANGER, WARNING, or CAUTION. This symbol may be used in conjunction with other symbols or pictographs.



Indicates an imminently hazardous situation, which, if not avoided, could result in death or serious injury.



Indicates a potentially hazardous situation, which, if not avoided, could result in death or serious injury.



Indicates a potentially hazardous situation, which, if not avoided, could result in minor or moderate injury.

NOTICE: Shown without Safety Alert Symbol indicates a situation that may result in property damage.

GENERAL SAFETY

KNOW YOUR POWER TOOL. Read the owner's manual carefully. Learn the tool's applications, work capabilities, and its specific potential hazards.

BEFORE USING YOUR MACHINE

To avoid serious injury and damage to the tool, read and follow all of the Safety and Operating Instructions before operating the machine.

1. **WARNING:** Some dust created by using power tools contains chemicals known to the State of California to cause cancer, birth defects, or other reproductive harm. Some examples of these chemicals are:

- Lead from lead-based paints.
- Crystalline silica from bricks, cement, and other masonry products.
- Arsenic and chromium from chemically treated lumber.

Your risk from these exposures varies, depending on how often you do this type of work. To reduce your exposure to these chemicals: work in a well ventilated area and work with approved safety equipment, such as those dust masks that are specially designed to filter out microscopic particles.

2. **READ** the entire Owner's Manual. **LEARN** how to use the tool for its intended applications.

3. **GROUND ALL TOOLS.** If the tool is supplied with a 3 prong plug, it must be plugged into a 3-contact electrical receptacle. The 3rd prong is used to ground the tool and provide protection against accidental electric shock. **DO NOT** remove the 3rd prong. See Grounding Instructions on the following pages.

4. **AVOID A DANGEROUS WORKING ENVIRONMENT.** **DO NOT** use electrical tools in a damp environment or expose them to rain.

5. **DO NOT** use electrical tools in the presence of flammable liquids or gasses.

6. **ALWAYS** keep the work area clean, well lit, and organized. **DO NOT** work in an environment with floor surfaces that are slippery from debris, grease, and wax.

7. **KEEP VISITORS AND CHILDREN AWAY. DO NOT** permit people to be in the immediate work area, especially when the electrical tool is operating.

8. **DO NOT FORCE THE TOOL** to perform an operation for which it was not designed. It will do a safer and higher quality job by only performing operations for which the tool was intended.

9. **WEAR PROPER CLOTHING. DO NOT** wear loose clothing, gloves, neckties, or jewelry. These items can get caught in the machine during operations and pull the operator into the moving parts. The user must wear a protective cover on their hair, if the hair is long, to prevent it from contacting any moving parts.

10. **CHILDPROOF THE WORKSHOP AREA** by removing switch keys, unplugging tools from the electrical receptacles, and using padlocks.

11. **ALWAYS UNPLUG THE TOOL FROM THE ELECTRICAL RECEPTACLE** when making adjustments, changing parts or performing any maintenance.

SAFETY INSTRUCTIONS

12. KEEP PROTECTIVE GUARDS IN PLACE AND IN WORKING ORDER.

13. AVOID ACCIDENTAL STARTING. Make sure that the power switch is in the “OFF” position before plugging in the power cord to the electrical receptacle.

14. REMOVE ALL MAINTENANCE TOOLS from the immediate area prior to turning “ON” the machine.

15. USE ONLY RECOMMENDED ACCESSORIES. Use of incorrect or improper accessories could cause serious injury to the operator and cause damage to the tool. If in doubt, check the instruction manual that comes with that particular accessory.

16. NEVER LEAVE A RUNNING TOOL UNATTENDED. Turn the power switch to the “OFF” position. **DO NOT** leave the tool until it has come to a complete stop.

17. DO NOT STAND ON A TOOL. Serious injury could result if the tool tips over, or you accidentally contact the tool.

18. DO NOT store anything above or near the tool where anyone might try to stand on the tool to reach it.

19. MAINTAIN YOUR BALANCE. DO NOT extend yourself over the tool. Wear oil resistant rubber soled shoes. Keep floor clear of debris, grease, and wax.

20. MAINTAIN TOOLS WITH CARE. Always keep tools clean and in good working order. Keep all blades and tool bits sharp, dress grinding wheels and change other abrasive accessories when worn.

21. EACH AND EVERY TIME, CHECK FOR DAMAGED PARTS PRIOR TO USING THE TOOL. Carefully check all guards to see that they operate properly, are not damaged, and perform their intended functions. Check for alignment, binding or breaking of moving parts. A guard or other part that is damaged should be immediately repaired or replaced.

22. DO NOT OPERATE TOOL WHILE TIRED, OR UNDER THE INFLUENCE OF DRUGS, MEDICATION OR ALCOHOL.

23. SECURE ALL WORK. Use clamps or jigs to secure the work piece. This is safer than attempting to hold the work piece with your hands.

24. STAY ALERT, WATCH WHAT YOU ARE DOING, AND USE COMMON SENSE WHEN OPERATING A POWER TOOL.

A moment of inattention while operating power tools may result in serious personal injury.

25. ALWAYS WEAR A DUST MASK TO PREVENT INHALING DANGEROUS DUST OR AIRBORNE PARTICLES, including wood dust, crystalline silica dust and asbestos dust. Direct particles away from face and body. Always operate tool in well ventilated area and provide for proper dust removal. Use dust collection system wherever possible. Exposure to the dust may cause serious and permanent respiratory or other injury, including silicosis (a serious lung disease), cancer, and death. Avoid breathing the dust, and avoid prolonged contact with dust. Allowing dust to get into your mouth or eyes, or lay on your skin may promote absorption of harmful material. Always use properly fitting NIOSH/OSHA approved respiratory protection appropriate for the dust exposure, and wash exposed areas with soap and water.

26. USE A PROPER EXTENSION CORD IN GOOD CONDITION. When using an extension cord, be sure to use one heavy enough to carry the current your product will draw. The table on the following page shows the correct size to use depending on cord length and nameplate amperage rating. If in doubt, use the next heavier gauge. The smaller the gauge number, the larger diameter of the extension cord. If in doubt of the proper size of an extension cord, use a shorter and thicker cord. An undersized cord will cause a drop in line voltage resulting in a loss of power and overheating.
USE ONLY A 3-WIRE EXTENSION CORD THAT HAS A 3-PRONG GROUNDING PLUG AND A 3-POLE RECEPTACLE THAT ACCEPTS THE TOOL’S PLUG.

27. ADDITIONAL INFORMATION regarding the safe and proper operation of this product is available from:

- Power Tool Institute
1300 Summer Avenue
Cleveland, OH 44115-2851
www.powertoolinstitute.org
- National Safety Council
1121 Spring Lake Drive
Itasca, IL 60143-3201
www.nsc.org
- American National Standards Institute
25 West 43rd Street, 4th Floor
New York, NY 10036
www.ansi.org
- ANSI 01.1 Safety Requirements for Woodworking Machines and the U.S. Department of Labor regulations
www.osha.gov

28. SAVE THESE INSTRUCTIONS. Refer to them frequently and use them to instruct others.

SAFETY INSTRUCTIONS

ELECTRICAL SAFETY

⚠ WARNING: THIS TOOL MUST BE GROUNDED WHILE IN USE TO PROTECT THE OPERATOR FROM ELECTRIC SHOCK.

IN THE EVENT OF A MALFUNCTION OR BREAKDOWN, grounding provides the path of least resistance for electric current and reduces the risk of electric shock. This tool is equipped with an electric cord that has an equipment grounding conductor and requires a grounding plug (not included). The plug **MUST** be plugged into a matching electrical receptacle that is properly installed and grounded in accordance with **ALL** local codes and ordinances.

DO NOT MODIFY ANY PLUG. If it will not fit the electrical receptacle, have the proper electrical receptacle installed by a qualified electrician.

IMPROPER ELECTRICAL CONNECTION of the equipment grounding conductor can result in risk of electric shock. The conductor with the green insulation (with or without yellow stripes) is the equipment grounding conductor. **DO NOT** connect the equipment grounding conductor to a live terminal if repair or replacement of the electric cord or plug is necessary.

CHECK with a qualified electrician or service personnel if you do not completely understand the grounding instructions, or if you are not sure the tool is properly grounded when installing or replacing a plug.

USE ONLY A 3-WIRE EXTENSION CORD THAT HAS THE PROPER TYPE OF A 3-PRONG GROUNDING PLUG THAT MATCHES THE MACHINE'S 3-PRONG PLUG AND ALSO THE 3-POLE RECEPTACLE THAT ACCEPTS THE TOOL'S PLUG. *

REPLACE A DAMAGED OR WORN CORD IMMEDIATELY.

This tool is intended for use on a circuit that has an electrical receptacle as shown in **FIGURE A**. It shows a 3-wire electrical plug and electrical receptacle that has a grounding conductor. If a properly grounded electrical receptacle is not available, an adapter as shown in **FIGURE B** can be used to temporarily connect this plug to a 2-contact ungrounded receptacle. The adapter has a rigid lug extending from it that **MUST** be connected to a permanent earth ground, such as a properly grounded receptacle box. **THIS ADAPTER IS PROHIBITED IN CANADA.**

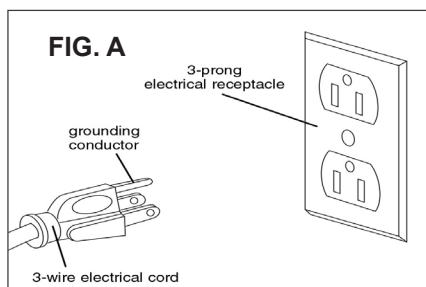

EXTENSION CORDS

⚠ WARNING: THE USE OF AN EXTENSION CORD WITH THIS MACHINE IS NOT RECOMMENDED. For best power and safety, plug the machine directly into a dedicated, grounded electrical outlet that is within the supplied cord length of the machine.

If an extension cord needs to be used, it should only be for a limited operation of the machine. The extension cord should be as short as possible in length, and have a minimum gauge size of 14AWG.

⚠ WARNING: Check extension cords before each use. If damaged replace immediately. Never use a tool with a damaged cord, since touching the damaged area could cause electrical shock, resulting in serious injury.

Use a proper extension cord. Only use cords listed by Underwriters Laboratories (UL). Other extension cords can cause a drop in line voltage, resulting in a loss of power and overheating of tool. When operating a power tool outdoors, use an outdoor extension cord marked "W-A" or "W". These cords are rated for outdoor use and reduce the risk of electric shock.

MINIMUM RECOMMENDED GAUGE FOR EXTENSION CORDS (AWG)

120 VOLT OPERATION ONLY				
	25' LONG	50' LONG	100' LONG	150' LONG
0 to 6 Amps	18 AWG	16 AWG	16 AWG	14 AWG
6 to 10 Amps	18 AWG	16 AWG	14 AWG	12 AWG
10 to 12 Amps	16 AWG	16 AWG	14 AWG	12 AWG

⚠ WARNING: Keep the extension cord clear of the working area. Position the cord so that it will not get caught on lumber, tools or other obstructions while you are working with your power tool.

* Canadian electrical codes require extension cords to be certified SJT type or better.

** The use of an adapter in Canada is not acceptable.

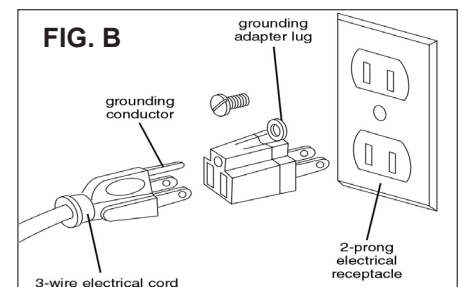

SAFETY INSTRUCTIONS

SPECIFIC SAFETY INSTRUCTIONS FOR PLANERS

This machine is intended for the surfacing of natural, solid woods. The permissible workpiece dimensions must be observed (see Technical Specifications). Any other use not as specified, including modification of the machine or use of parts not tested and approved by the equipment manufacturer, can cause unforeseen damage and invalidate the warranty.

ATTENTION: Use of this planer still presents risks that cannot be eliminated by the manufacturer. Therefore, the user must be aware that wood working machines are dangerous if not used with care and all safety precautions are adhered to.

1. Do not operate this machine until you have read all of the following instructions.
2. Do not attempt to operate this machine until it is completely assembled.
3. Do not turn ON this machine if any pieces are damaged or missing.
4. This machine must be properly grounded.
5. If you are not familiar with the operation of the machine, obtain assistance from a qualified person.
6. Always wear approved, safety protective eye wear and hearing protection when operating this machine.
7. Always wear a dust mask and use adequate dust collection and proper ventilation.
8. Do not wear loose clothing or jewelry when operating this machine. Keep long hair tied back.
9. Always make sure the power switch is in the OFF position prior to plugging in the machine.
10. Always make sure the power switch is in the OFF position and the machine is unplugged when doing any cleaning, assembly, setup operation, or when not in use.
11. Make sure all safety guards and hardware are securely tightened before operating the machine.
12. Regularly check that the blades are locked tight in the cutterhead.
13. Always keep hands and fingers away from the cutterhead, chip exhaust opening, feed rollers, belts and pulleys to prevent injury.
14. Never plane wood less than 7" long, widths under 3/4", or material less than 3/16" thick.
15. Never make planing cuts deeper than 1/8". Multiple cuts, 1/16" or less, produce better finish results.
16. Make sure there are no loose knots, nails, staples, dirt or foreign objects in the work piece to be surfaced.
17. Use extra caution with large, warped, very small or awkward work pieces. Joint warped boards flat before planing.
18. Use extra supports (roller stands, saw horses, tables etc,) for any work pieces large enough to tip when not held down to the table top surfaces.
19. Surface wood in the same direction of the grain, not across the grain. Never plane end cuts or end grain.
20. Plane only one work piece at a time. Vary the feeding of the work pieces along the cutterhead, center/left/right, so that all of the knives get used and thus remain sharp, longer.
21. Never reach inside of a running machine, and avoid awkward operations and hand positions where a sudden slip could cause fingers or a hand to move into the cutterhead.
22. Do not clear a jammed work piece while the machine is running. Stop the machine, unplug it from the power source, and then remove the jammed work piece. Lowering the table may be necessary to dislodge the work piece.
23. Keep your face and body to one side of the machine during use, out of line with a possible 'kick back' (lumber caught in by the rotating cutterhead and thrown back towards the operator).
24. The use of any accessories or attachments not recommended may cause injury to you and damage your machine.
25. Sharpen or replace dull or chipped knives immediately, as injury to the user, or the machine, may result.
26. Replacement knives/inserts should be from, or through a source recommended by the manufacturer.
27. Remove material or debris from the work area. Keep work area neat and clean.

This owner's manual is not a teaching aid and is intended to show assembly, adjustments, and general use.

California Proposition 65 Warning



WARNING: Drilling, sawing, sanding or machining wood products can expose you to wood dust, a substance known to the State of California to cause cancer. Avoid inhaling wood dust or use a dust mask or other safeguards for personal protection. For more information go to www.P65Warnings.ca.gov/wood.

GETTING TO KNOW YOUR MACHINE

- A Feed Speed Lever (2 Speeds)
- B On / Off Safety Switch with Reset Button
- C Depth Gauge
- D Infeed Extension Table
- E Thickness Scale
- F Repeat Cut Indicator
- G Lifting Handle (x2)
- H Thickness Adjusting Handwheel

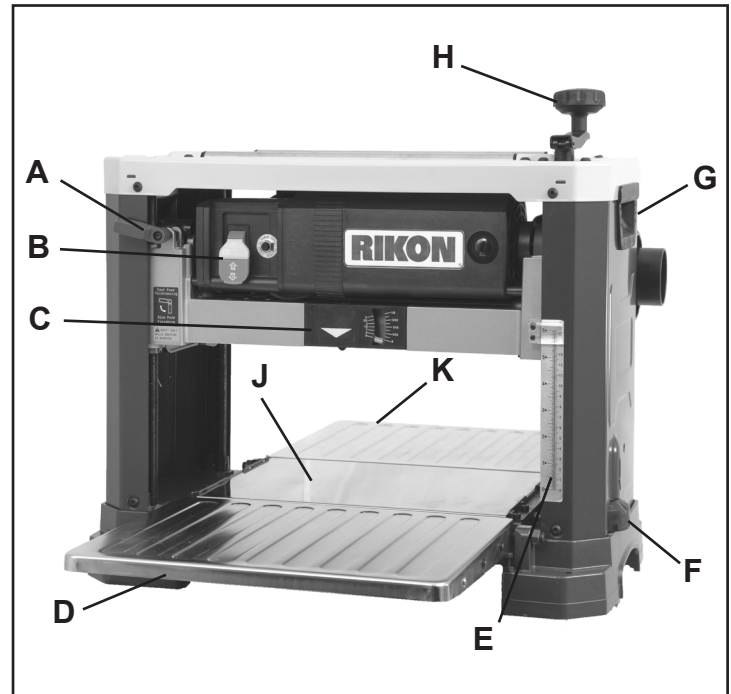
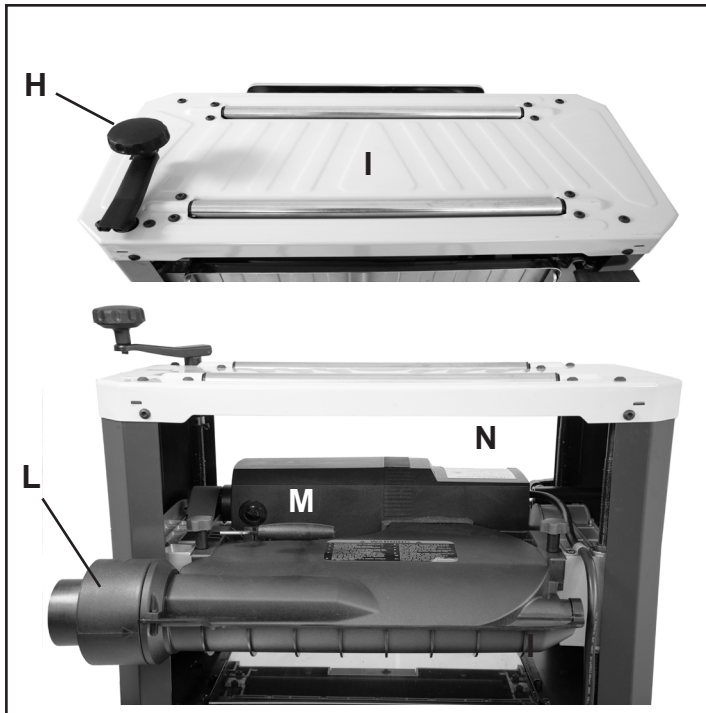

- I Flat Top w/ Rollers for Stock Returning
- J Planer Table
- K Outfeed Extension Table
- L Dust Chute with End Cover
- M Tool Storage Holders
- N Motor & Cutterhead

SEE PAGES 18 - 21 FOR THE PARTS DIAGRAMS AND PARTS LISTS

CONTENTS OF PACKAGE

Model 25-135H 13" Portable Planer is shipped complete in one box.

UNPACKING AND CLEAN-UP

1. Carefully remove all contents from the shipping carton. Compare the contents with the list of contents to make sure that all of the items are accounted for, before discarding any packing material. Place parts on a protected surface for easy identification and assembly. If any parts are missing or broken, please call RIKON Customer Service (877-884-5167) as soon as possible for replacements. **DO NOT** turn your machine ON if any of these items are missing. You may cause injury to yourself or damage to the machine.
2. Report any shipping damage to your local distributor. Take photographs for any possible insurance claims.
3. Clean all rust protected surfaces with ordinary house hold type grease or spot remover. Do not use; gasoline, paint thinner, mineral spirits, etc. These may damage painted surfaces.
4. Apply a coat of paste wax to the table to prevent rust. Wipe all parts thoroughly with a clean dry cloth. Be careful when reaching inside of the planer as the knives are sharp and may cause injury if touched.
5. Set packing material and shipping carton aside. Do not discard until the machine has been set up and is running properly.

CONTENTS OF PACKAGE

LIST OF LOOSE PARTS



- A. Planer
- B. Dust Hood & Chute
- C. Star T25 Screwdriver
- D. Dust Hood Knobs
- E. Dust Hose Adapter 4" to 2-1/2"
- F. ON/Off Switch Safety Key Lock
- G. Hex Wrench & Handle Screw
- H. Height Adjustment Handwheel
- I. Manual & Warranty Card (not shown)

INSTALLATION

MOVING & INSTALLING THE PLANER

CAUTION When moving the planer, only use the carry handles that are located on the side of the planer. **DO NOT** carry or move it using the infeed and outfeed extensions, dust chute or handwheel.

1. The machine should be firmly bolted to a stand, workbench to avoid any movement of the machine during use. The planer's base has holes in each of the four corners for this purpose (hardware is not included).

For portability and secure clamping of the planer to a workbench, the planer can be first permanently bolted to a piece of plywood. Then the planer can be positioned on your workbench, or other solid surface, and the plywood can be clamped in place to secure the planer for use. After use, the plywood can be unclamped and the planer stored away for future use.

2. When positioning the machine on a solid, level bench that is located in an area that ample space in front and in back of the planer for the moving of lumber to be milled. Align the machine so that during use, any kickback will not face aisles, doorways, or other work areas that bystanders may be in. Do not locate or use the machine in damp or wet conditions.



WARNING

THE MACHINE MUST NOT BE PLUGGED IN AND THE POWER SWITCH MUST BE IN THE 'OFF' POSITION UNTIL ASSEMBLY IS COMPLETE.

NOTE: The 25-135H Planer requires minimal assembly, and therefore the machine can be mounted to a stand, workbench, or on a piece of plywood for portability and storage before assembling of the parts begins.

TOOLS REQUIRED FOR ASSEMBLY

Straightedge or level

To check and adjust the extension tables level to the planer table.

ASSEMBLY

INSTALLING THE HANDWHEEL KNOB for Height Setting of the Thickness Table

1. Locate the Handle Screw and Height Adjustment Handwheel.
2. Place the Height Adjustment Handwheel onto the shaft at top corner of the Planer.
3. Tighten the Handle Screw with the supplied 4mm hex wrench. FIG. 1.

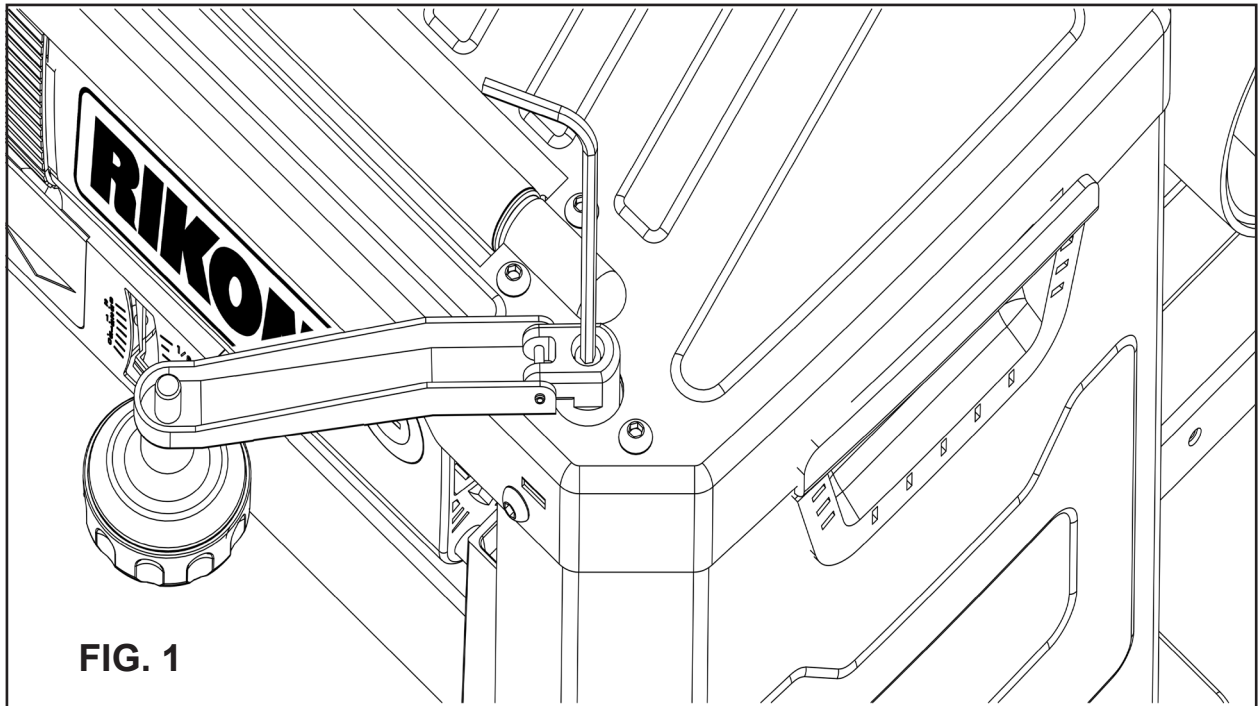

INSTALLING THE DUST PORT

1. From the back of the machine, place the Dust Hood over the Cutterhead Assembly.
2. Locate the two Dust Hood Knobs (A, Fig.2).
3. Align the Dust Hood over the holes on the top of the Cutterhead Assembly, and tighten the Dust Hood Knobs by turning them clockwise.
4. To minimize sawdust accumulation on your workpiece, attach either a 2-1/2 in. or a 4 in. vacuum hose to the dust port end.

NOTE: Make sure all connections are secure and your dust collector is turned on before any milling of lumber is done.

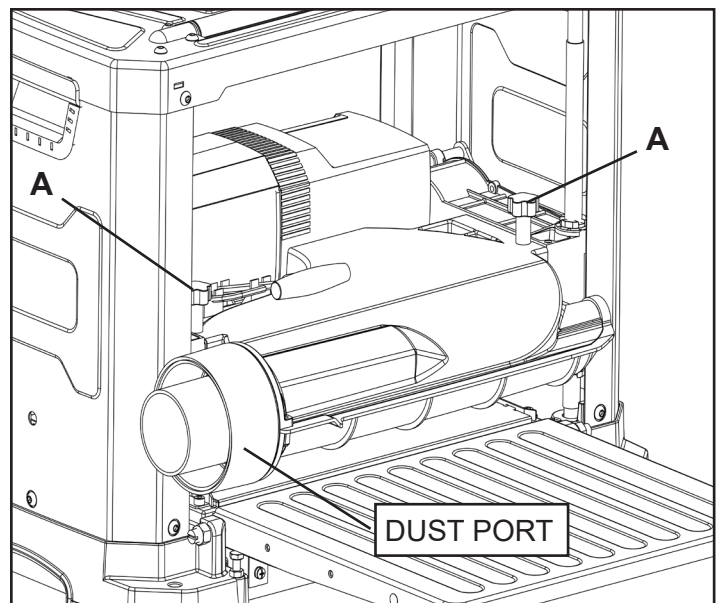

FIG. 2

ADJUSTMENTS

LEVELING THE TABLE EXTENSIONS

1. The infeed and outfeed table extensions are attached to the planer. Shipped in a folded, upright position, the table extensions must be in the down position before planing can begin. For accurate planing, the table extensions must be level with the planer table.

NOTE: For optimum performance, always check to make sure that the table extensions are level before beginning planing operations.

To level:

1. Place a straight edge or level across both the planer table and the table extensions. Check to see if the extensions are level with the planer table. FIG. 3.
2. If an adjustment is necessary, lift each table extension and loosen the two lock nuts that are located under the table on each side. Adjust the two stop screws until the extension table is level with the planer table.
3. Press down on the table extension to ensure that the table extension is properly seated.
4. Tighten the lock nuts securely when the leveling adjustments are complete. Do this adjustment on both extension tables.

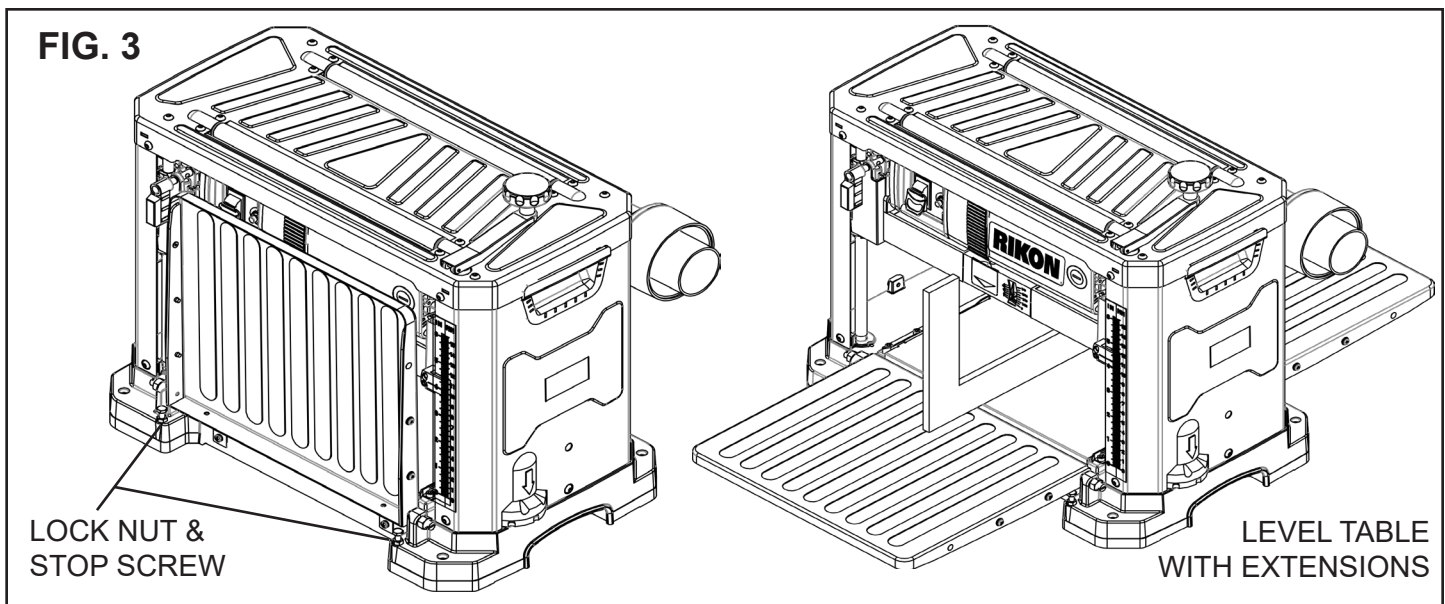

ADJUSTING THE DEPTH OF PLANING

The depth gauge indicates the amount of wood being removed in a planing pass. The workpiece must be positioned under the depth gauge on the front of the planer. FIG. 4. Each full revolution of the handle will raise or lower the cutterhead by 1/16 in. (1.58MM).

Never make a planing cut deeper than:

- 1/8 in. (3mm) for material up to 6 in. (152mm) wide
- 1/16 in. (1.6mm) for material 6-13 in. (330mm) wide

CAUTION: DO NOT continuously use the planer at the maximum depth of cut, 1/8 in. (3mm), as it will put excessive stress on the motor which will damage it.

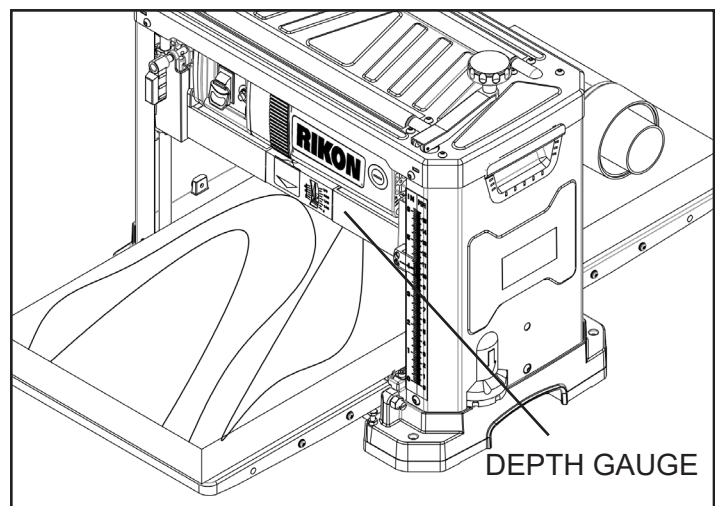

FIG. 4

ADJUSTMENTS

REPLANING using the REPEAT CUT

1. Remove the screws to take off the height adjustment hand-wheel (1 screw), remove the right side panel (3 screws) and top cover (4 screws). FIG. 5.

2. Lower the cutterhead assembly until the stop screw rests on the step block.

3. Plane a scrap piece of wood, then measure the thickness of the finished piece. It should be the same as the thickness scale and repeat cut indicator.

4. If an adjustment is necessary, use a wrench to loosen the lock nut and adjust the stop screw to correct the height.

5. Once the adjustment is made, retighten the lock nut and the stop screw securely.

6. Install the right side panel, top cover and height adjustment handwheel back onto the planer.

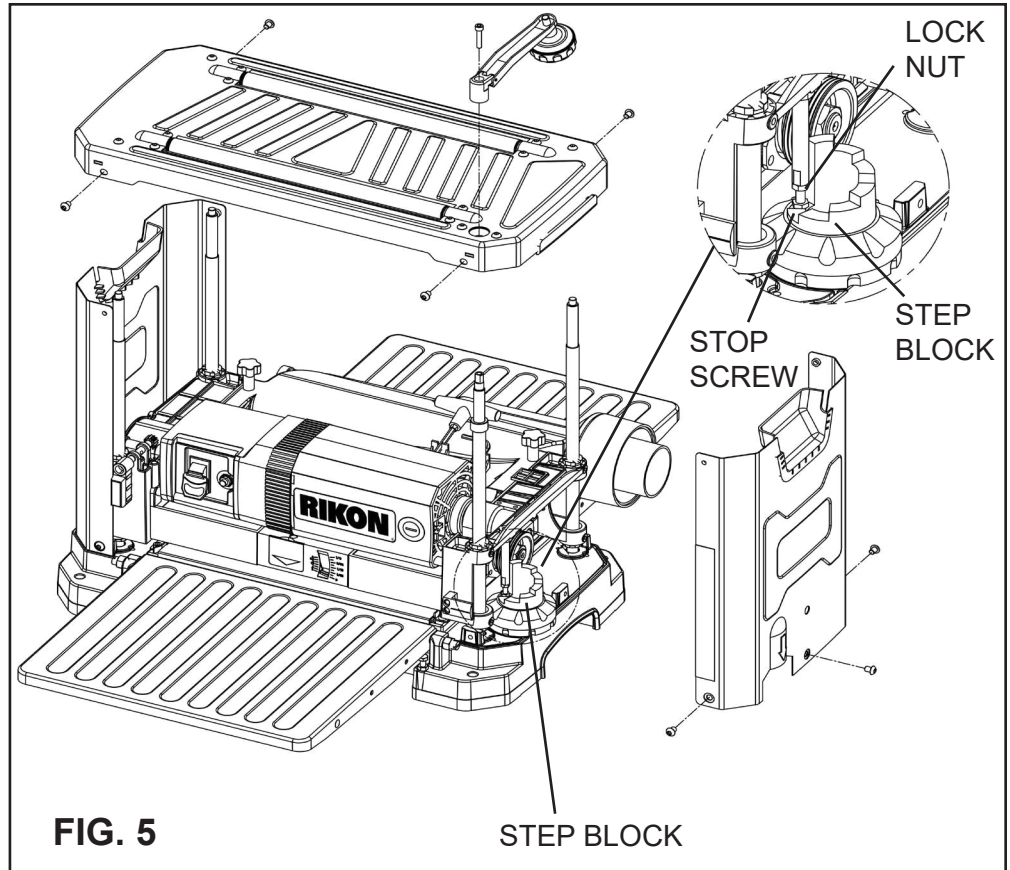

FIG. 5

STEP BLOCK

WARNING THE MACHINE MUST NOT BE PLUGGED IN AND THE POWER SWITCH MUST BE IN THE OFF POSITION UNTIL ALL ADJUSTMENTS ARE COMPLETE.

THICKNESS SCALE ADJUSTMENT

Located on the right front of the planer, the thickness scale shows the depth of the finished workpiece. Inaccurate cuts can be prevented by routinely checking the alignment of the thickness scale.

1. Table extensions must be level with planer table.

2. Plane a scrap piece of wood, then measure the thickness of the finished piece.

3. If properly adjusted, the thickness of the finished piece should be the same as indicated on the scale.

4. If out of adjustment, loosen the two screws holding the scale indicator and adjust the scale indicator, up or down, to point to the correct setting on the scale.

5. Retighten the two scale indicator screws securely.

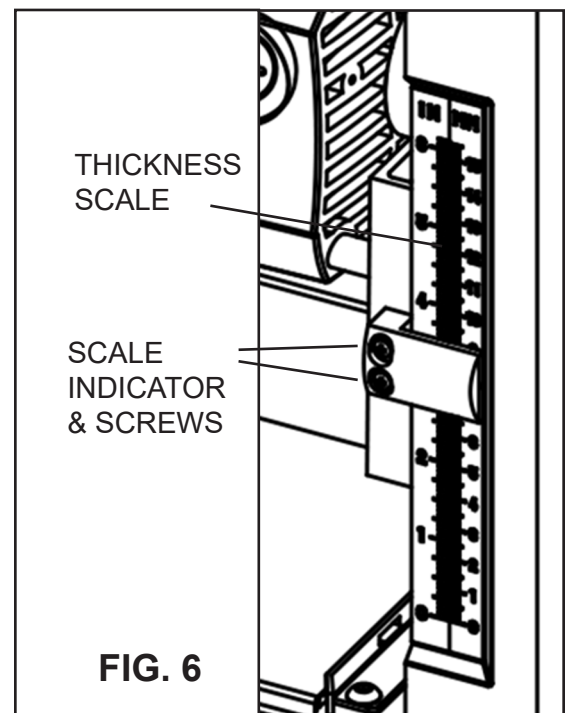

FIG. 6

OPERATION

PLANING

- Thickness planers work best if at least one side of the workpiece has a flat surface. When both sides of a
- workpiece are rough, use a surface planer or jointer first to define the initial flat surface. Plane one side of the workpiece then flip the workpiece and plane the surface of the reverse side.
- Always plane both sides of a workpiece to reach the desired thickness. This will leave the workpiece with
- uniform moisture to prevent warp during the drying process.
- When one end of the workpiece is thicker than the opposite end by more than 1/8 in. (3mm), make several cuts with the planer starting with light planing cuts first. Light cuts create a finer finish than heavier cuts.
- Do not plane a workpiece less than 3/16 inch (5mm) thick.
- Do not lower the cutterhead assembly lower than 3/16 inch (5mm).
- Do not plane a workpiece less than 3/4 inch (19mm) wide.
- Do not plane workpiece shorter than 7 inch (177.8mm) long. Short boards should be planed end to end with other boards to prevent kick-back and snipe.
- Boards longer than 24" should have additional support as they enter and exit the planer.
- Do not plane more than one workpiece at a time.
- Run boards through the planer at different positions along the width of the bed to utilize all of the insert cutters along the length of the cutterhead. Planing only in the center, or through one side of the planer, will quickly dull the knives in that area.
- ALWAYS keep the cutter inserts sharp for best cutting results.

PLANNER OPERATION

NOTE: Before turning on the planer, review the safety precautions listed above and on pages 3 to 6. Make sure that you fully understand the features, adjustments and capabilities of the machine that are outlined throughout this manual.

1. To feed the workpiece into the machine, assume proper operating position, FIG. 7. Stand offset to one side of the feed opening to avoid any kick-back, should it occur. Do not push the lumber once the infeed roller has been engaged. Let the infeed roller move the workpiece into the planer at its own pace.

2. To remove the workpiece from the machine, position yourself offset to one side of the outfeed opening. FIG. 7. Do not pull the lumber as it exits the machine. Let the outfeed roller move the workpiece out of the planer at its own rate, but support the lumber as it extends past the extension rollers.

PLANNER FEED RATE SPEED CHANGE

The feed speeds of this planer can be adjusted by the Feed Speed Lever. FIG. 8.

- Start the motor.
- Select the desired feed speed. Lowering the lever provides 16 feet/min. Raising the lever up will change the feed rate to 26 feet/min.

NOTE: The feed speed lever only can be operated when the motor is running. **DO NOT** change the feed speed while a board is being planed.

Damage to the machine may result.

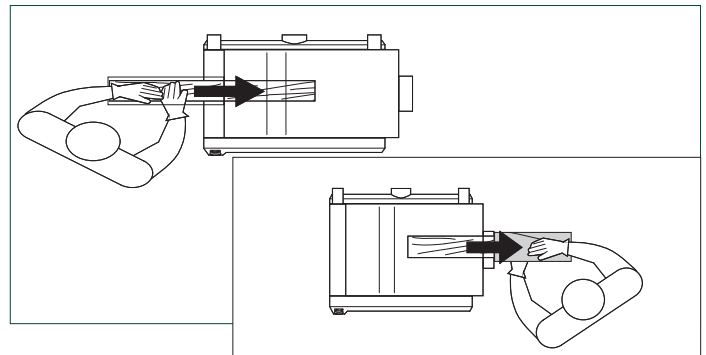

FIG. 7

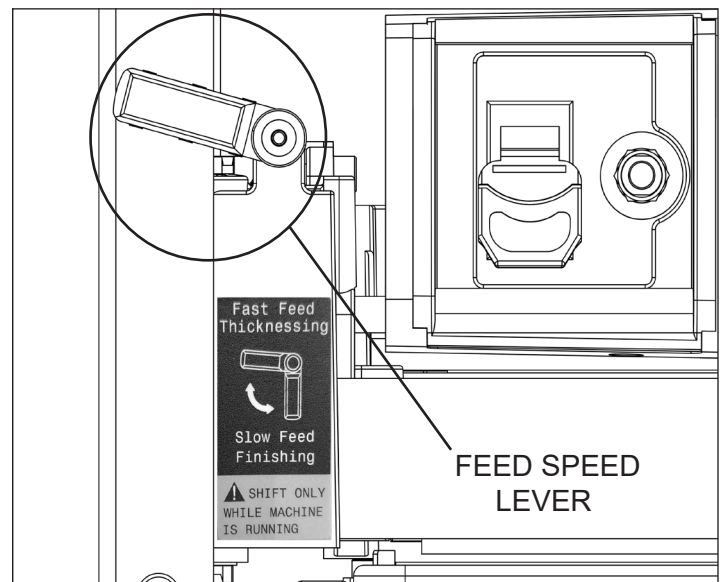

FIG. 8

OPERATION

POWER SWITCH

The planer is turned on by flipping the switch into the up position and it is turned off by flipping the switch in the down position. This planer is also equipped with a special lockout toggle switch that prevents unauthorized use.

To prevent unauthorized use of the planer, simply pull out the yellow key located on the face of the switch. See illustration on page 7, item B.

- **TURN ON THE PLANER:** Insert the switch key into the switch, lift the switch to ON.
- **TURN OFF THE PLANER:** Insert switch key into the switch, push the switch back to OFF.
- **TO LOCK THE PLANER:** Place the switch in the OFF position. Remove the switch key from the switch and keep it in a safe place until the planer is to be used again.

SNIPE

Snipes, or depressions made at either end of a workpiece by cutter inserts, can occur when the board is not properly supported. Although snipe may be barely noticeable, it is important to keep the workpiece parallel and flat with the planer table to minimize snipe.

- Butting workpieces end-to-end as they are fed through the planer will minimize the problem for shorter pieces, because it provides a more stable feed through the whole cut.
- For stock longer than 48 in.(122cm), greater care must be taken to reduce the problem. The longer workpiece length means more weight is unsupported by the planer table and extensions, causing the shifting weight to work against keeping the stock flat, especially at the entry or exiting of the stock from the planer.
- To remove snipe from a finished workpiece, cut off the end of the stock where snipe is noticeable.

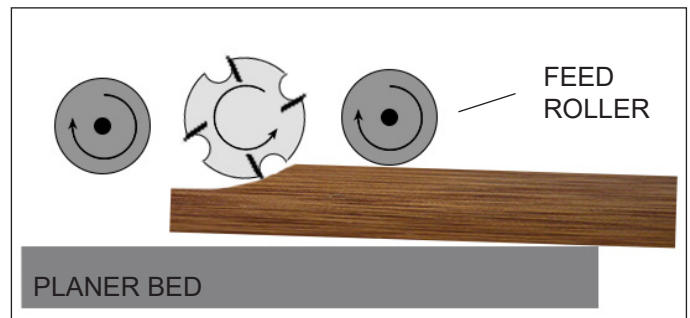

FIG. 9

WARPED WOOD

Little or no warpage is the ideal condition for planing a workpiece. Simply turn the workpiece over and plane it to the desired thickness. Otherwise, plane the top flat first, turn the workpiece over and plane the bottom.

- For a board that is cupped or bowed across its width, the best method is to rip the board lengthwise down the middle and plane the pieces separately. This method eliminates much of the waste in planing cupped or bowed workpieces.
- The only way to remove the bow from a workpiece that is cupped or bowed down its length is to use a jointer.
- Avoid using severely warped wood as it can jam the planer. If it must be used, rip it in half before planing to help minimize the possibility of jamming. If jamming does occur, turn the switch off and unplug the planer immediately. Raise the cutterhead assembly high enough to remove the workpiece easily. Carefully check to make sure no damage to the tool has occurred before making the next planing pass.
- Always feed the workpiece in the direction of the grain. This allows the cutter blades to sever the wood fibers instead of tearing them. Feeding against the grain can also cause the cutters to chip the workpiece.

DUST COLLECTION

It is extremely important that a dust collection system is used with this planer to eliminate harmful airborne dust, prevent the build-up of chips that may jam the roller system in the cutterhead, and to keep the working area clean of debris. The planer is supplied with 4" and 2-1/2" dust ports for attaching your choice of hose to your vacuum system. Make sure all connections are secure and your dust collector is turned on before any milling of lumber is done.

MAINTENANCE



WARNING

THE MACHINE MUST NOT BE PLUGGED IN AND THE POWER SWITCH MUST BE IN THE 'OFF' POSITION UNTIL ADJUSTMENTS ARE COMPLETE.

ROTATING OR REPLACING KNIFE INSERTS

This machine has a cutterhead with 6 rows of High Speed Steel knife inserts. Each of the 26 inserts on the cutterhead are indexed and have two sharpened sides. If the knives become dull, or one becomes nicked, simply loosen the retaining screws with the supplied star head screwdriver, lift up and rotate the inserts 90° to a new sharpened edge. No setting is required, as the cutterhead has been machined to automatically index and set the inserts in proper position for use. When both sides of an insert are dull, the insert can be easily removed and a new knife insert placed in the location.

To rotate or remove an knife insert:

1. Unplug power cable, put the switch to OFF and remove the safety key.
 2. Lower the upper frame motor housing to the lowest position near the planer bed by turning the handwheel.
 3. From the back of the planer, remove the two Dust Hood Knobs and take off Dust Hood. (A-FIG. 10.)
 4. Remove any sawdust from the head of the Star screw then remove the screw and cutter insert.
 5. Safely rotate the cutterhead by inserting the supplied 4mm hex wrench into the side of the planer (B-FIG. 10.). Engage the end of the cutterhead with the wrench and rotate to the next row.
 6. While the insert is removed, clean any resin buildup or trapped dust from the insert and surfaces of the cutterhead with a suitable solvent. A tooth brush works well for safe cleaning around the sharp inserts. Using compressed air is also useful. Be sure to wear safety glasses if compressed air is used.
- NOTE:** Any accumulated dust or resin buildup can affect the seating of the insert in the cutterhead, raise it, and can make noticeable marks on your workpieces the next time you plane.
7. Lubricate the Star screw threads with a light machine oil, wipe the excess oil off the threads.
 8. Install a new insert, or rotate the old insert so that a new sharpened edge is in position. The inserts have a indication mark on their top surface corner, so that you can reference the positioning of the insert's dulled or sharpened edges. When rotating a cutter insert, it will seat itself back against the positioning bar during tightening. Install the Star screw and torque it down to 48-50 inch / pounds. Inserts have 2 sharp edges, 2 flat edges. See FIG. 11, page 15.
 9. Once all insert changes have been made, put the planer parts back together by reversing steps 2-4 above.
 10. Plug in the power cord and safety key when you are ready to resume planing.

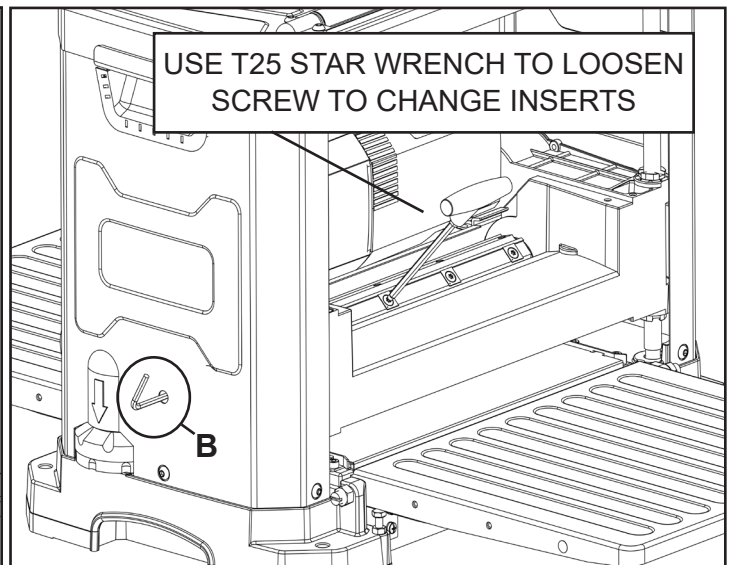
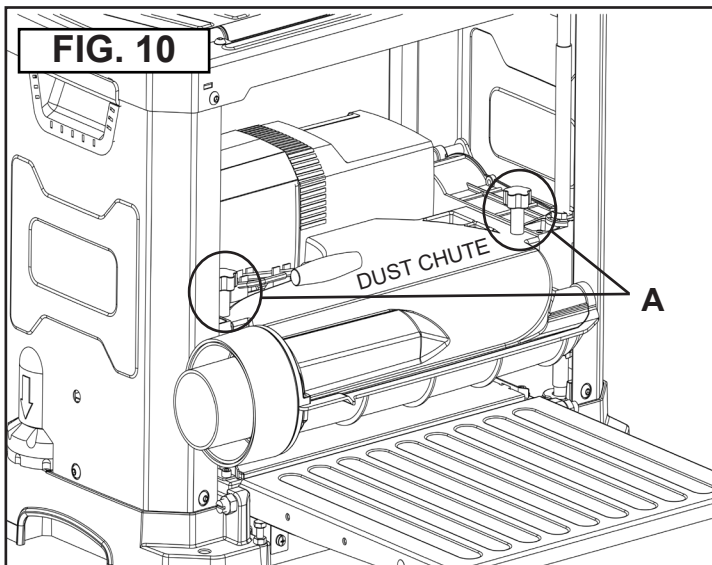

MAINTENANCE

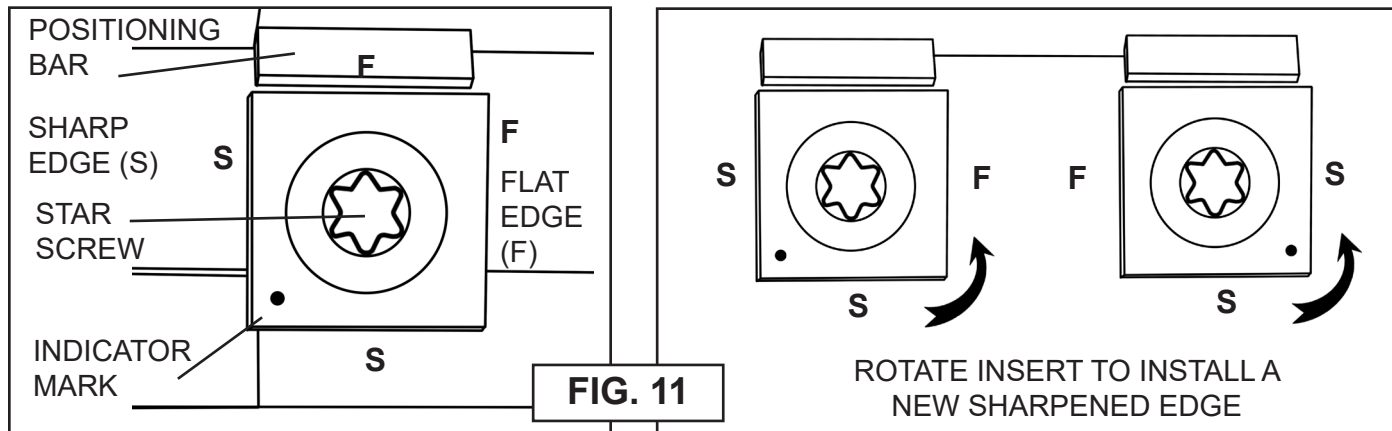

WARNING

THE MACHINE MUST NOT BE PLUGGED IN AND THE POWER SWITCH MUST BE IN THE 'OFF' POSITION UNTIL ADJUSTMENTS ARE COMPLETE.

BRUSH REPLACEMENT

Brush life will vary depending on the load placed on the motor. The brushes should be inspected every 10-15 hours of use. To inspect the brushes:

1. Unplug power cable, put the switch to OFF and remove the safety key.
2. Remove the two Brush Holders. One is located on the front right of the motor housing, FIG. 12, the other is located in the same position on the rear of the motor assembly. The brush holders can be removed using a flat-head screwdriver.
3. Once the brush has been removed, inspect the carbon, the spring, and the wire.
4. If the carbon of either brush is worn down to 1/4" or less, both brushes should be replaced. Also, if the spring or wire are burned or damaged in any way, both brushes should be replaced.
5. After inspection or replacement of the brushes, replace the brush holders.
6. Plug in the power cable and safety key when you are ready to resume planing.

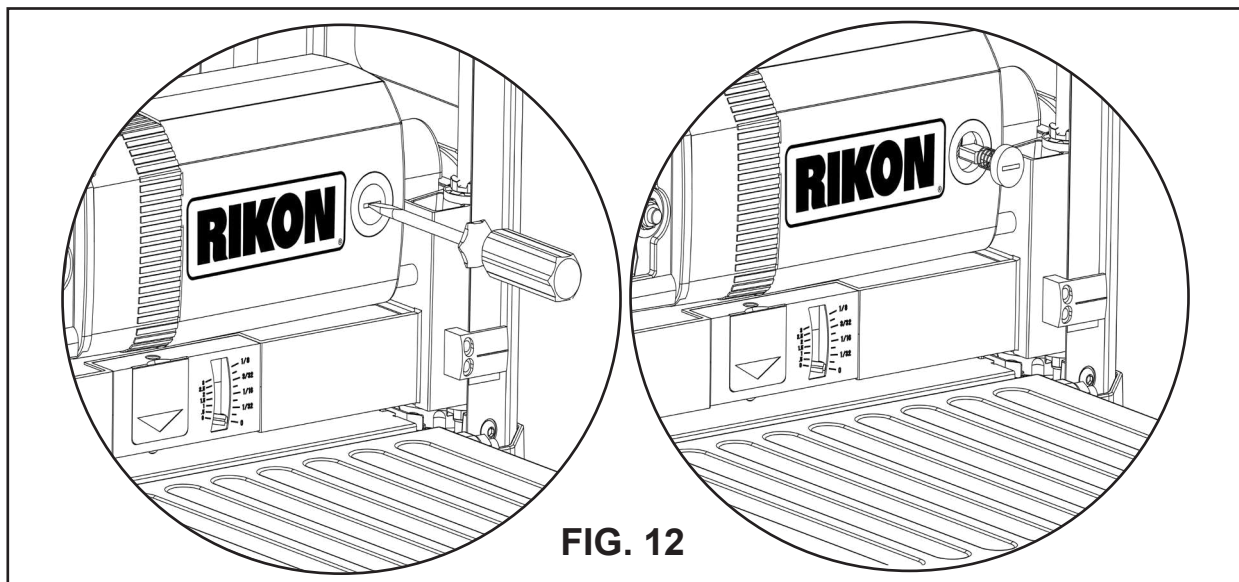

MAINTENANCE

⚠ WARNING: Turn the power switch “OFF” and disconnect the plug from the outlet prior to adjusting or maintaining the machine. DO NOT attempt to repair or maintain the electrical components of the motor. Contact a qualified service technician for this type of maintenance.

1. Before each use:

- Check the power cord and plug for any wear or damage.
- Check for any loose screws or hardware.
- Check the area to make sure it is clear of any misplaced tools, lumber, cleaning supplies, etc. that could hamper the safe operation of the planer.

2. To avoid a build-up of wood dust, regularly clean all parts of the machine using a soft cloth, brush or compressed air. A general cleaning should be done after every use to avoid future problems and ensure the machine is in ready condition for the next time it is used.

WARNING: If blowing sawdust, wear proper eye protection to prevent debris from blowing into eyes.

3. Check the knives to make sure that they are not loose from the cutterhead, dull or nicked. Making sure that they are in proper operating condition will ensure that the quality of your surfaced lumber will be the best possible.

4. Clean and lubricate any moving parts regularly with a few drops of penetrating oil and lubricated with a light coating of medium weight machine oil. Cutterhead ball bearings are lifetime lubricated, sealed, and do not need any further care. Keep the drive belts free of oil and grease.

5. Clean the planer bed columns on a regular basis to prevent the build-up of wood chips and dust. Treat the posts with a dry lubricant spray. Do not use ordinary oil which will collect dust and hamper the operation of the machine.

6. Keep the planer tables free of resin and rust. Clean them regularly with a non-flammable solvent, then coat with a light film of dry lubricant spray, or quality paste wax, to enhance the passage of work pieces on/over the planer table and extensions.

WARNING: When cleaning or working on the tables, avoid the risk of personal injury by cuts that may result from touching the knife inserts' sharp edges! Raise the planer table to its maximum 'up/thickness' position, so that there is ample distance between the table and the cutterhead's sharp inserts for your safety.

7. Clean the feed rollers with a soft rag, and non-flammable tar and pitch remover if there is resin build-up. Be careful to keep hands away from the sharp cutterhead knife inserts. Do not apply any lubricant to the rollers as they must 'grab' the lumber to move it through the planer and so must not slip.

8. Check the motor brushes every 10 - 15 hours of operation. Install new brushes as necessary. See page 15 for information on the process.

WIRING DIAGRAM

⚠ WARNING: This machine must be grounded. Replacement of the power supply cable should only be done by a qualified electrician. See page 5 for additional electrical information.

This tool is intended for use on a circuit that has a 120 volt electrical receptacle. The illustration on page 5 shows the type of 120v, 3-wire electrical plug and receptacle that has a grounding conductor that is required.

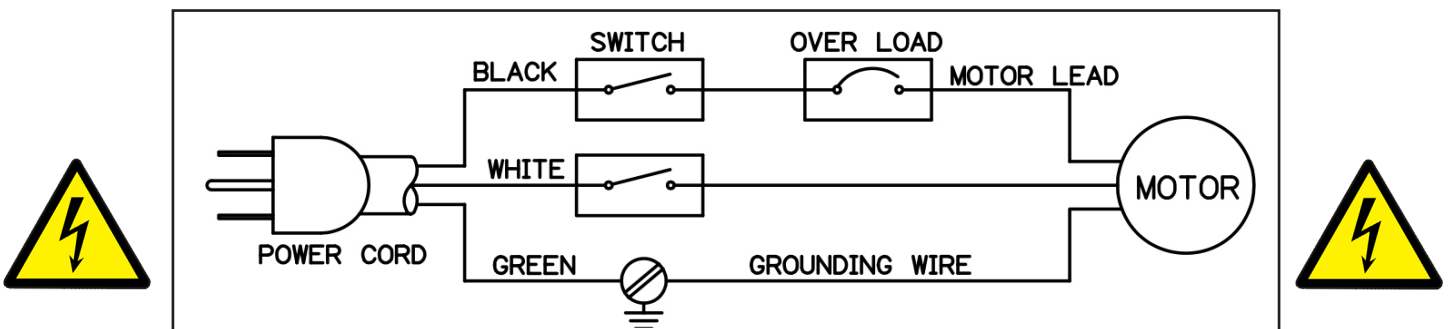

TROUBLESHOOTING



FOR YOUR OWN SAFETY, ALWAYS TURN OFF AND UNPLUG THE MACHINE BEFORE CARRYING OUT ANY TROUBLESHOOTING.

SYMPTOM	POSSIBLE CAUSES	SOLUTIONS
Planer will not start.	<ol style="list-style-type: none"> 1. No power 2. Blown shop fuse 3. Main on/off switch is not working or the safety key is not inserted 4. Motor failure 	<ol style="list-style-type: none"> 1. Check power source, plug and wiring. 2. Check fuse, replace if it is blown. 3. Check position of the switches. Contact local dealer for repair or replacement. 4. Inspect motor for failed components. Contact Dealer for repair or replacement.
Shop's Circuit Breakers trip and /or Fuses are blown	<ol style="list-style-type: none"> 1. Wrong circuit size for machine 2. Motor is overloaded under strain from taking too heavy of cut 3. Use of a long extension cord 	<ol style="list-style-type: none"> 1. Check circuit/fuse rating and amps of the motor. Install CORRECT rated breaker/fuse. 2. Take lighter cuts in planing lumber. 3. No extension cord, or use higher gauge.
Planer feed rate and cutting is not consistent	<ol style="list-style-type: none"> 1. Chips, resin and dust build-up on the planer tables and parts. 	<ol style="list-style-type: none"> 1. Unplug planer from the power source and clean the planer parts.
Planed lumber thickness does not match the thickness scale indicator	<ol style="list-style-type: none"> 1. Indicator scale is not set correctly. 	<ol style="list-style-type: none"> 1. Adjust thickness scale indicator.
Small raised lines are running along the surface	<ol style="list-style-type: none"> 1. Knives are nicked or broken 	<ol style="list-style-type: none"> 1. Rotate insert knives to new sharp edges.
Snipe on board ends (NOTE: Snipe can be reduced, but not fully eliminated)	<ol style="list-style-type: none"> 1. Lumber not supported when fed into or exiting the planer 2. Short boards not butted 	<ol style="list-style-type: none"> 1. Support long boards with roller stands. 2. Run boards butt end to end through the planer.
Planed surface is torn	<ol style="list-style-type: none"> 1. Cutting against the grain 2. Cut is too deep 3. Knives are dull 	<ol style="list-style-type: none"> 1. Cut with the grain. For figured woods, take shallow cuts to minimize tear out. 2. Reduce cutting depth to 1/16" or less. 3. Rotate insert knives to new sharp edges.
Planed surface grain is rough, raised or fuzzy	<ol style="list-style-type: none"> 1. Lumber has a high moisture content 2. Cut is too deep 3. Knives are dull 	<ol style="list-style-type: none"> 1. Reduce the moisture content by drying it, or plane other properly seasoned lumber. 2. Reduce cutting depth to 1/16" or less. 3. Rotate insert knives to new sharp edges.
Planed surface is glossy	<ol style="list-style-type: none"> 1. Cutting depth is too shallow 2. Knives are dull 	<ol style="list-style-type: none"> 1. Increase depth of cut slightly. 2. Rotate insert knives to new sharp edges.

For parts or technical questions contact: techsupport@rikontools.com or 877-884-5167.



PARTS LIST

KEY NO.	DESCRIPTION	PART NO.	KEY NO.	DESCRIPTION	PART NO.
1	TOP COVER	P25-135H-1	55	SCREW HEX HD M8xP1.25x20L	P25-135H-55
1A	ROLLER TUBE	P25-135H-1A	56	GEAR (INTERMEDIATE)	P25-135H-56
1B	SUPPORT	P25-135H-1B	57	RING RETAINING EXT	P25-135H-57
1C	ROLLER	P25-135H-1C	58	GEAR SPINDLE	P25-135H-58
1D	SPECIAL WASHER	P25-135H-1D	59	RING RETAINING EXT	P25-135H-59
1E	SCREW M4xP0.7x8L	P25-135H-1E	60	SPEED CHANGE LEVER	P25-135H-60
2	SCR HEX SOC BUT HD M6xP1.0x8L	P25-135H-2	61	KEY	P25-135H-61
3	RETAINER BEARING for top cover2	P25-135H-3	62	SPLINED SPINDLE	P25-135H-62
4	ELEVATION NUT	P25-135H-4	63	BEARING RETAINER	P25-135H-63
5	RETAINER BEARING for top cover2	P25-135H-5	64	WASHER	P25-135H-64
6	UPPER FRAME	P25-135H-6	65	MOTOR PULLEY	P25-135H-65
7	LEFT SIDE PANEL	P25-135H-7	66	V-BELT	P25-135H-66
8	RIGHT SIDE PANEL	P25-135H-8	67	NUT HEX	P25-135H-67
9	KNOB	P25-135H-9	68	BALL BEARING	P25-135H-68
10	HANDLE BAR	P25-135H-10	69	HSS INSERT CUTTERS - Pack of 10	25-499
10A	HANDLE BAR	P25-135H-10A	69	CARBIDE INSERT CUTTERS - PK 10	25-499C
11	SCR HEX SOC BUT HD M6xP1.0x10L	P25-135H-11	70	HELICAL CUTTERHEAD	P25-135H-70
12	SCR PAN CR TAP M3xP1.0x16L	P25-135H-12	71	TORX SCREW M5xP0.8x15.6L	P25-135H-71
13	IDLER	P25-135H-13	72	NUT HEX SPECIAL M8xP1.25x13	P25-135H-72
14	IDLER SHAFT	P25-135H-14	73	ROD STEP	P25-135H-73
15	SPINDLE	P25-135H-15	74	NUT HEX M5xP0.8	P25-135H-74
16	HEIGHT ADJ SPINDLE	P25-135H-16	75	SCRW HEX HD M5xP0.8x25L	P25-135H-75
17	HEX SOC HD SCR M5xP0.8x20L	P25-135H-17	76	SCREW M5xP0.8x6L	P25-135H-76
18	HAND KNOB ASSEMBLY #18A~18F	P25-135H-18	77	SCREW PAN CR M3xP0.5x20L	P25-135H-77
19	BASE	P25-135H-19	78	SPECIAL HEX SOC HD CAP SCR M5	P25-135H-78
20	HEX WRENCH	P25-135H-20	79	NUT M4	P25-135H-79
21	TORX WRENCH	P25-135H-21	80	POINTER	P25-135H-80
22	BELT GUARD	P25-135H-22	81	HOUSING POINTER	P25-135H-81
23	SPACER	P25-135H-23	82	BUSHING	P25-135H-82
24	NYLOCK SCR SOC SET CUP PT M5	P25-135H-24	83	PHILLIPS SCREW M4xP0.7x10L	P25-135H-83
25	INDICATOR DEPTH	P25-135H-25	84	COVER POINTER	P25-135H-84
26	PLUNGER	P25-135H-26	85	SPRING COIL 8.5x19x0.8	P25-135H-85
27	CUTTERHEAD PULLEY	P25-135H-27	86	ROD POINTER ELEVATING	P25-135H-86
28	PLATE	P25-135H-28	87	SCR PN CR TYTT M5xP0.8x8L	P25-135H-87
29	SPRING COIL	P25-135H-29	88	LOCKWASHER EXT	P25-135H-88
30	SPECIAL WASHER	P25-135H-30	89	FAST FEED / SLOW FEED LABEL	P25-135H-89
31	SPRING	P25-135H-31	90	C-RING	P25-135H-90
32	STEEL BALL	P25-135H-32	91	SPROCKET	P25-135H-91
33	SPROCKET	P25-135H-33	91A	SPROCKET	P25-135H-91A
34	SCR SEMS L/WASH	P25-135H-34	92	CHAIN	P25-135H-92
35	BLOCK STEP	P25-135H-35	93	SPRING COIL LEFT	P25-135H-93
36	BLOCK STEP BASE	P25-135H-36	94	BLOCK BEARING	P25-135H-94
38	SPECIAL WASHER	P25-135H-38	95	OUTFEED ROLLER	P25-135H-95
39S	DUST HOOD ASSY. #9+#12+#39~42+#203	P25-135H-39S	96	SPRING COIL RIGHT	P25-135H-96
39	DUST HOOD	P25-135H-39	97	PLATE RETAINER	P25-135H-97
39A	DEFLECTOR PLATE	P25-135H-39A	98	SCR HEX SOC CAP M5xP0.8x10L	P25-135H-98
40	HOOD DOOR	P25-135H-40	99	INFEED ROLLER	P25-135H-99
41	DIRECTIONAL HALF RING	P25-135H-41	101	GEAR PINION	P25-135H-101
42	VAC ADAPTOR	P25-135H-42	101A	GEAR BOX COMBINATION	P25-135H-101A
44	SPRING FLAT	P25-135H-44	113	SCR SEMS S/WASH	P25-135H-113
45	SCR SEMS S/WASH M5xP0.8x10L	P25-135H-45	115	SPACER	P25-135H-115
46	SCR SEMS W/WASH M4xP0.7x10L	P25-135H-46	116	SCR SEMS L/WASH	P25-135H-116
47	SCREW M5xP0.8x8L	P25-135H-47	117	RAIL GUIDE	P25-135H-117
48	DUST CHUTE PLATE	P25-135H-48	118	PLATE WEAR	P25-135H-118
49	SET SCR M5xP0.8x8L	P25-135H-49	119	EXTENSION TABLE	P25-135H-119
50	SCR PAN CR M5xP0.8x8L	P25-135H-50	128	SCALE THICKNESS	P25-135H-128
51	CLAMP CORD	P25-135H-51	129	SPACER	P25-135H-129
52	SCR HEX SOC HD LOCK M4	P25-135H-52	130	GASKET FOAM	P25-135H-130
53	WASHER	P25-135H-53	131	SCR HEX SOC HD LOCK	P25-135H-131
54	WASHER	P25-135H-54	132	CONNECTING ROD	P25-135H-132





MOTOR ASSEMBLY

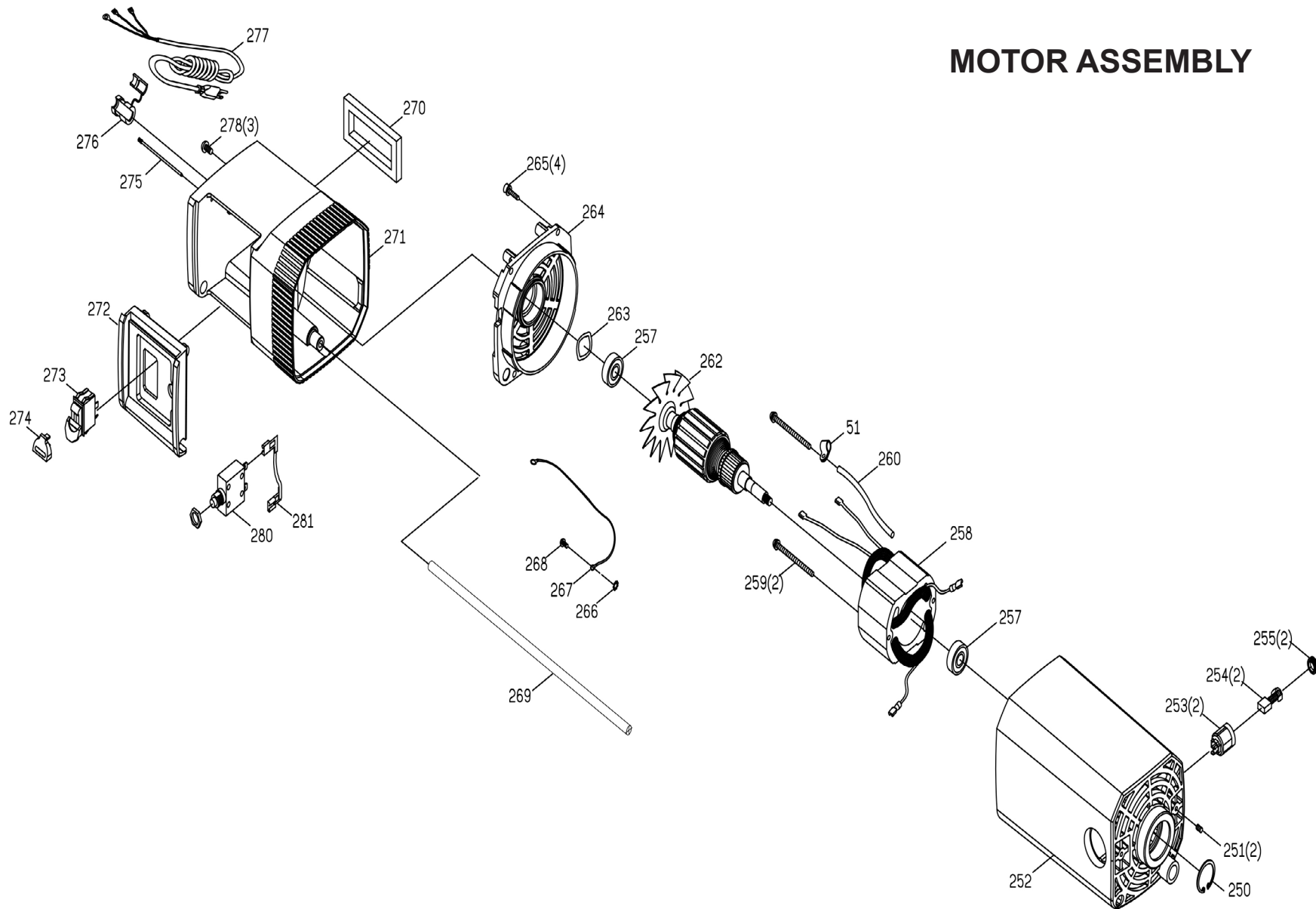

20

for Replacement Parts.
For Parts under Warranty, the Serial Number of your
machine is required.



KEY NO.	DESCRIPTION	PART NO.
133	COVER GEARBOX	P25-135H-133
134	SCR PAN CR M5xP0.8x10L	P25-135H-134
136	BOLT ADJUSTING M10xP1.5	P25-135H-136
137	NUT HEX SPECIAL	P25-135H-137
140	SCREW HEX M6xP1.0x25L	P25-135H-140
141	NUT HEX	P25-135H-141
142	BALL BEARING	P25-135H-142
143	WASHER	P25-135H-143
144	SCR HEX SOC CAP M4xP0.7x12L	P25-135H-144
146	CHAIN	P25-135H-146
147	SCR HEX SOC CAP M5xP0.8x25L	P25-135H-147
155	WASHER	P25-135H-155
164	WASHER	P25-135H-164
250S	MOTOR ASSY. #250~#281	P25-135H-250S
252	HOUSING MOTOR	P25-135H-252
253	HOLDER BRUSH	P25-135H-253
254	BRUSH	P25-135H-254
255	CAP BRUSH	P25-135H-255
271	SWITCH HOUSING	P25-135H-271
272	BEZEL SWITCH	P25-135H-272
273	SWITCH	P25-135H-273
274	KEY SWITCH	P25-135H-274
277	CORD W/PLUG	P25-135H-277
280	OVERLOAD SWITCH	P25-135H-280
281	LEAD WIRE	P25-135H-281

NOTE: Please reference the Part Number when calling for Replacement Parts.
For Parts under Warranty, the Serial Number of your machine is required.

RIKON

POWER TOOLS®

5-Year Limited Warranty

RIKON Power Tools Inc. ("Seller") warrants to only the original retail consumer/purchaser of our products that each product be free from defects in materials and workmanship for a period of five (5) years from the date the product was purchased at retail. This warranty may not be transferred.

This warranty does not apply to defects due directly or indirectly to misuse, abuse, negligence, accidents, repairs, alterations, lack of maintenance or normal wear and tear. Under no circumstances will Seller be liable for incidental or consequential damages resulting from defective products. All other warranties, expressed or implied, whether of merchantability, fitness for purpose, or otherwise are expressly disclaimed by Seller. This five-year warranty does not cover products used for commercial, industrial or educational purposes. The warranty term for these claims will be limited to a two-year period.

This limited warranty does not apply to accessory items such as blades, drill bits, sanding discs, grinding wheels, belts, guide bearings and other related items.

Seller shall in no event be liable for death, injuries to persons or property, or for incidental, contingent, special, or consequential damages arising from the use of our products.

To take advantage of this warranty, proof of purchase documentation must be provided which has the date of purchase and an explanation of the complaint.

The Seller reserves the right to effect at any time, without prior notice, those alterations to parts, fittings, and accessory equipment which they may deem necessary for any reason whatsoever.

To register your machine online, visit RIKON at www.rikontools.com/warranty

To take advantage of this warranty, or if you have any questions, please contact us at 877-884-5167 or email warranty@rikontools.com



For more information:
16 Progress Road
Billerica, MA 01821

877-884-5167 / 978-528-5380
techsupport@rikontools.com



Link to RIKON Website