

# Setup Manual for Fax, Printer & Copier

MFC 4550

MFC 6550MC

MFC 7550MC

Please complete the following check list when you set up your machine.

Check ✓	STEP	Page
	Selecting a suitable location for your machine.	1-1
	Check the supplied items.	1-2
	Install the Drum Unit assembly.	2-1
	Load Paper into the machine.	2-2
	Attach the trays.	2-5
	Connect your MFC to your computer.	2-7
	Connect the handset, the power cord and telephone line.	2-6
	(Connect a Telephone Answering Device.)	2-8
	Set the dialing mode (Tone/Pulse).	3-1
	Set the date and time.	3-2
	Set the station ID.	3-3
	Set the beeper sound level.	3-5
	Set up the Multi-Function Link Pro software.	3-13
	Set up the windows® operating software. (See the Multi-Function Link Pro Manual.)	
	(Set up One-Touch and Speed-Dial numbers.)	3-6~9
	Test your machine.	4-1

#### FCC COMPLIANCE

This equipment has been tested and found to comply with the limits for a Class B digital device, pursuant to Part 15 of the FCC rules. These limits are designed to provide reasonable protection against harmful interference in a residential installation. This equipment generates, uses and can radiate radio frequency energy and if not installed and used in accordance with the instructions, may cause harmful interference to radio communications. However, there is no guarantee that interference will not occur in a particular installation. If this equipment does cause harmful interference to radio or television reception, which can be determined by turning the equipment off and on, the user is encouraged to try to correct the interference by one or more of the following measures:

- Reorient or relocate the receiving antenna.
- Increase the separation between the equipment and the receiver.
- Connect the equipment to an outlet on a circuit different from that to which the receiver is connected.
- Consult with the dealer or an experienced radio/TV technician for help.

## Introduction to the Setup Manual

- ▶ **Read this manual first** to set up your machine and prepare your computer for the printer mode.

This Setup Manual will help you prepare your machine to operate as a fax, printer and copier.

- ▶ **Your Multi-Function Center 6550MC/7550MC** has 6 performance modes in one machine. It is a Fax, Printer, Copier, Scanner, PC Fax and Message Center.

- ▶ **And your MFC 4550** has 5 performance modes. It is a Fax, Printer, Copier, Scanner and PC Fax.

- ▶ After you complete setting up the MFC, **see the “Operations Manual for Fax, Printer, Copier”** for more information about your MFC such as functions of machine and the control panel. Information about maintenance, troubleshooting and technical specifications are also available in this Manual.

- ▶ **See the “Multi-Function Link Pro Manual for Scanner & PC Fax”** for information on how to set up your machine and computer, and how to use the scanner and PC Fax.

# TABLE OF CONTENTS

• ..... FOR YOUR INFORMATION

## **1. SUITABLE PLACE AND PACKING LIST ..... 1-1**

- Choosing a Suitable Place for Your Machine ..... 1-1
  - The Good Places..... 1-1
  - And the Bad Places..... 1-1
- Checking All Supplied Items ..... 1-2

## **2. MECHANICAL SETTINGS ..... 2-1**

- A. Installing the Drum Unit Assembly (with Toner Cartridge) .... 2-1
- B. Loading Paper into the MFC machine ..... 2-2
  - Acetabel Paper: ..... 2-4
- C. Setting Up the MFC ..... 2-5
- D. Connecting the MFC to the Computer ..... 2-7
- E. Connecting a Telephone Answering Device (TAD)..... 2-8
  - Hooking up the Telephone Answering Device ..... 2-8
  - If your machine is MFC 4550:..... 2-9
  - If your machine is MFC 6550MC/7550MC:..... 2-9
  - Recotding the TAD's Outgoing Message (OGM) ..... 2-10
- F. Connecting to Different Types of Phone Lines ..... 2-11
  - Roll Over Phone Lines..... 2-11
  - Two Line Phone System ..... 2-11
  - Converting Telephone Wall Outlets..... 2-11
  - Installing a MFC, Two Line TAD and Two Line Telephone ..... 2-12
  - Connecting Your Machine to a Multi Line system (PBXs) 2-13
  - Connecting to a Private Branch Exchange ..... 2-13
  - Custum Features on Your Phone Line ..... 2-13

## **3. SOFTWARE SETTINGS ..... 3-1**

- A. TELEPHONE FUNCTION SETTINGS ..... 3-1
  - Setting the Dialing Mode (Tone/Pulse)..... 3-1
  - Setting the Date and Time ..... 3-2
  - Setting the Station ID ..... 3-3
  - Setting the Beeper Volume Level..... 3-5
  - Storing the One-Touch Dial Numbers ..... 3-6
  - Storing the Speed-Dial Numbers ..... 3-8
    - When You Wish to Change the Stored One-Touch and Speed-Dial Numbers (During Step 6 on Page 3-6, 8) ..... 3-10
    - Memory Storage/Temporary Battery Back Up..... 3-10
  - Setting Up Number Groups for Broadcasting..... 3-11

# TABLE OF CONTENTS

B. MULTI-FUNCTION LINK PRO SOFTWARE SETTINGS ....	3-13
1) FOR WINDOWS® USERS .....	3-13
Setting Up Windows® 95 for the MFC .....	3-13
Setting Up Windows® 3.1 for the MFC .....	3-14
2) FOR DOS USERS (Only for MFC 6550MC/7550MC) .....	3-15
How to Use the MFC with Your DOS Application Software .....	3-15
What Does the Remote Printer Console Do? .....	3-16
Installing the Remote Printer Console .....	3-16
Using the Remote Printer Console Main Program .....	3-17
Remote Printer Console .....	3-18
Printer Setup Category .....	3-19
Using the Printer Status Monitor Program .....	3-21
<b>4. TEST YOUR MACHINE .....</b>	<b>4-1</b>
Print a Test Sample Page .....	4-1
Send a Test Sheet by Fax .....	4-1
<b>5. INDEX .....</b>	<b>5-1</b>

# SUITABLE PLACE AND PACKING LIST

## 1. SUITABLE PLACE AND PACKING LIST

### Choosing a Suitable Place for Your Machine

Use the following list as a guide to find a suitable place for your machine.

#### The Good Places...

Place your machine in a location where the temperature stays between 50-90.5°F (10-32.5°C).

Place your machine on a flat, stable surface, such as a desk or table.

Select a place that is free from vibration and shocks.

The main plug on this equipment must be used to disconnect main power.

Please ensure the socket outlet is installed near the equipment and is easily accessible.

#### And the Bad Places...

Avoid setting it up in a high-traffic area.

Avoid setting up the machine near heaters, air conditioners, water, chemicals, or refrigerators.

Do not select a place that exposes your machine to direct sunlight, excessive heat, humidity, moisture, or dust.

Do not connect your machine to electrical outlets controlled by wall switches or automatic timers. This will cause a disruption of power and can wipe out information from the unit's memory.

Do not connect your machine to electrical outlets on the same circuit as large appliances or other equipment that might disturb the power supply.

Avoid placing the machine close to interference sources, such as speakers or the base units of cordless phones.

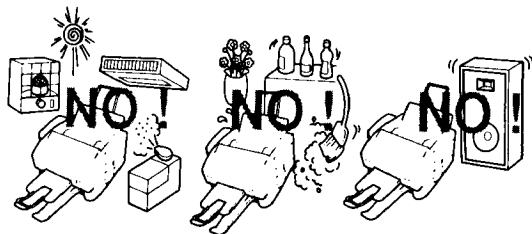

# SUITABLE PLACE AND PACKING LIST

## Checking All Supplied Items

Check to make sure you have the supplied items included in your box.

\*4550...6pcs included

\*6550MC/7550MC...9pcs included

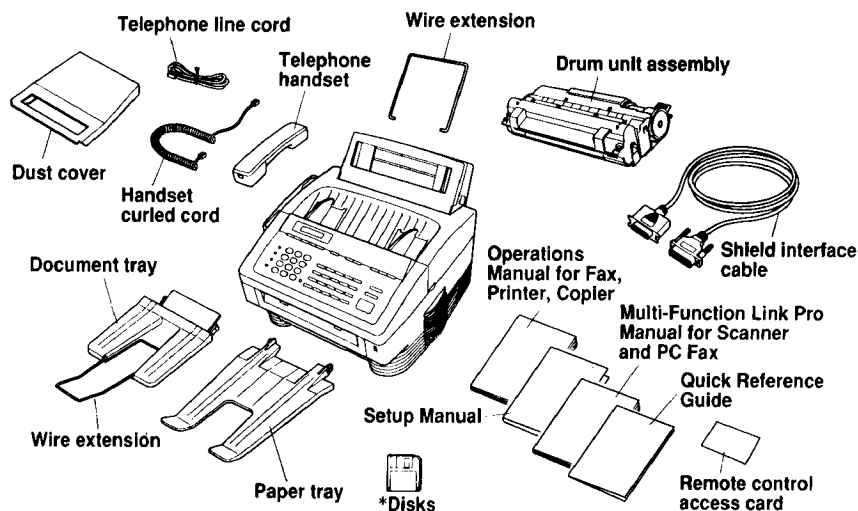

### Helpful Hints

Please check to make sure you have all the items shown before disbanding the carton.

If you plan on shipping the machine, we recommend you keep and re-use the original carton and packing materials.

### NOTICE

- Never install telephone wiring during a lightning storm.
- Never install telephone jacks in wet locations unless the jack is specifically designed for wet locations.
- Never touch telephone wires or terminals that are not insulated unless the telephone line has been disconnected at the network interface.
- Use caution when installing or modifying telephone lines.
- Avoid using a telephone (other than a cordless type) during an electrical storm. There may be a remote risk of electric shock from lightning.
- Do not use the telephone to report a gas leak in the vicinity of the leak.
- For **PLUGGABLE EQUIPMENT**, the socket-outlet should be installed near the equipment and should be easily accessible.

## 2. MECHANICAL SETTINGS

Follow these steps to set up your machine.

### A. Installing the Drum Unit Assembly (with Toner Cartridge)

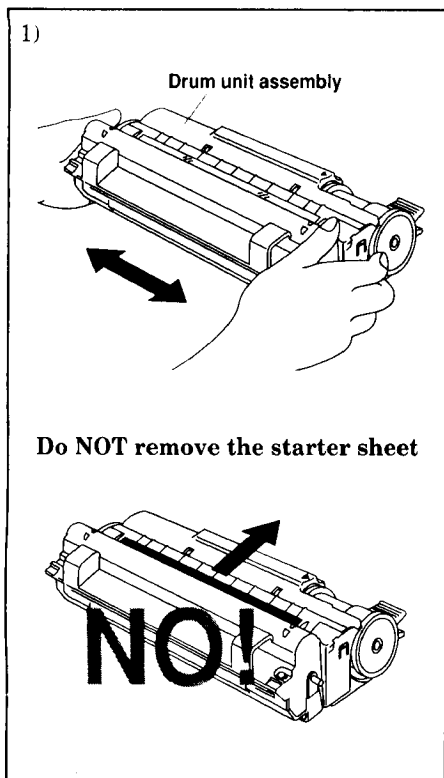

- 1) Unpack the drum unit assembly including the toner cartridge and gently rock it from side to side five or six times. Unseal the tape on the toner cartridge lever.

#### WARNING

Do not expose the drum unit to light for longer than a few minutes because it will damage the drum.

#### WARNING

Do not remove the starter sheet. This sheet will be ejected while the machine is warming up after installing a new drum unit. (See page 2-7.)

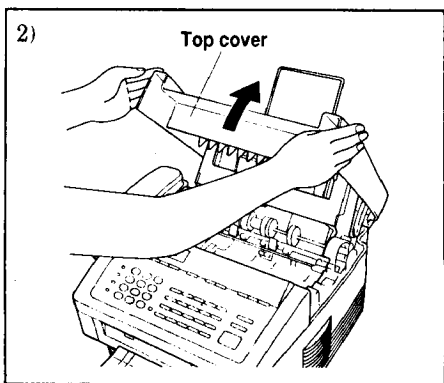

- 2) Open the top cover of the MFC until the latch clicks into place.

## MECHANICAL SETTINGS

3)

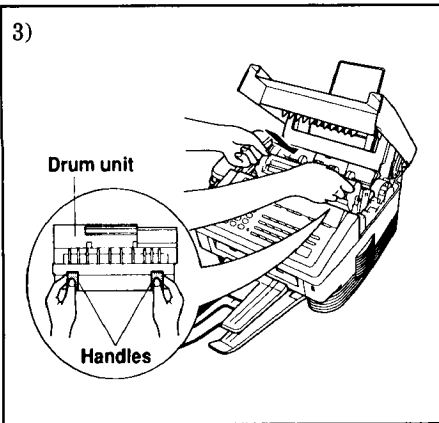

3) Holding the drum unit by its handles, insert it into the MFC machine.

4)

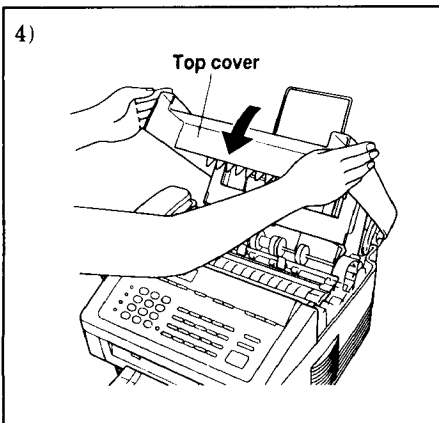

4) Close the top cover.  
(See page 13-1 of the Operations Manual for more information about replacement of the toner cartridge.)

### B. Loading Paper into the MFC machine

1)

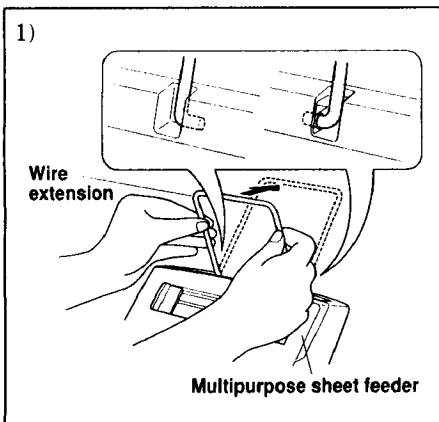

1) Hook the wire extension into the multipurpose sheet feeder.

# MECHANICAL SETTINGS

2) To install the paper, fan the paper well and then tap the leading edge of the pages on a flat surface so they are even.

3) Open the multipurpose sheet feeder cover.

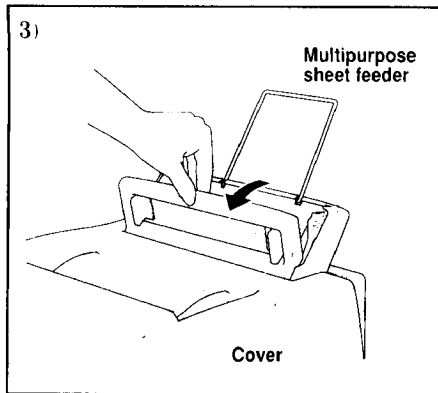

4) Load paper in the multipurpose sheet feeder.

## NOTE

The feeder can hold up to 200 sheets of plain paper or up to 10 envelopes. Excessive sheets may cause paper jams. Make sure the paper level is stacked below the ► mark.

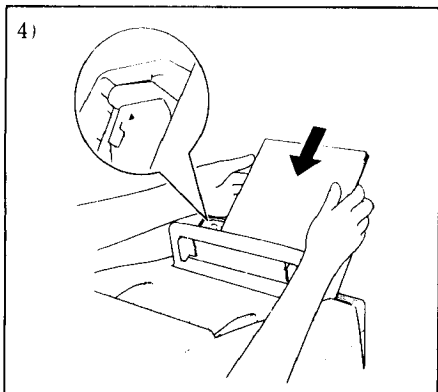

5) Move the paper guide to fit the paper width.

## WARNING

Failure to set the paper guide to the paper width may cause paper to skew and jam.

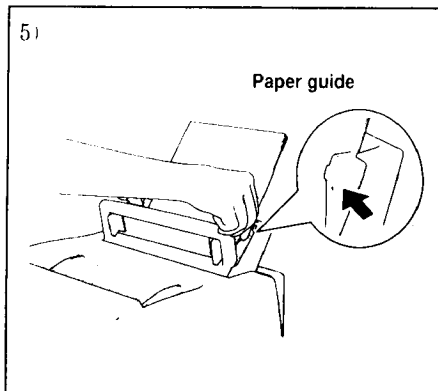

## MECHANICAL SETTINGS

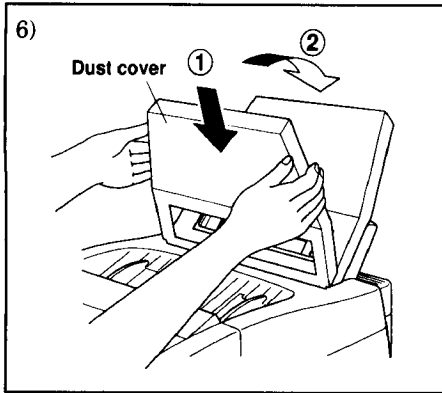

- 6) Attach the dust cover to the multipurpose sheet feeder cover.

### NOTE

- It is essential to use the dust cover for your MFC to prevent dust from entering the drum unit and causing damage.
- Using the dust cover on your MFC will prolong the drum unit life.

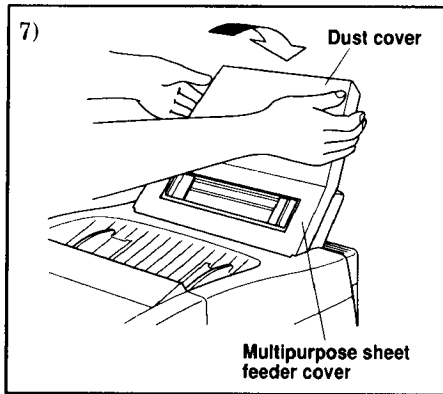

- 7) Close the multipurpose sheet feeder cover.

### • Acceptable Paper :

The MFC can handle paper that has the following specifications:  
But please note that you can receive fax messages only on Letter, Legal and A4 paper.  
And if you use legal or A4 sheet, you have to change the Recording Paper Size setting, which is Function 1-5-6 (See Operations Manual page 6-7).

Paper Type	Paper Size
Cut sheet	A4, Letter, Legal, B5, A5, Executive, Custom size 2.75-8.5 x 5-14 inches (70-216 x 127-356 mm)
Envelopes	DL, C5, COM-10, Monarch, 9" x 12"
Post Card	2.75-8.5 x 5-11 inches (70-216 x 127-356 mm)
Organizer	Day-Timer® J, K, L, M 2.75-8.5 x 5-11 inches (70-216 x 127-356 mm)
Labels and Transparencies	2.75-8.5 x 5-14 inches (70-216 x 127-356 mm)

# MECHANICAL SETTINGS

## Paper Capacity in Feeder

### Multipurpose

Sheet Feeder: Up to 0.87 inch (22 mm) in height (up to the mark) Approx. 200 sheets of 20 lb. (75 g/m<sup>2</sup>) or 50 sheets of 42 lb. (158 g/m<sup>2</sup>) A4/Letter paper, or 10 envelopes

Output Tray: Approx. 100 sheets of 20 lb. (75 g/m<sup>2</sup>) A4/Letter paper

	Cut Sheet	Envelope
Basis Weight	16 to 42 lb. (60 to 158 g/m <sup>2</sup> )	20 to 24 lb. (75 to 90 g/m <sup>2</sup> ) single thickness
Caliper	±0.03 to ±0.08 in. (0.08 to 0.2 mm)	0.0033 to 0.0058 in. (0.084 to 0.14 mm) single thickness
Moisture Content	4% to 6% by weight	4% to 6% by weight
Smoothness	100 to 250 (Sheffield)	100 to 250 (Sheffield)

## Recommended paper types:

Cut sheet: Xerox 4200

Label: Avery laser label or equivalent

Transparency: 3M CG3300 or equivalent

## C. Setting Up the MFC

### 1) Attach the document and paper trays

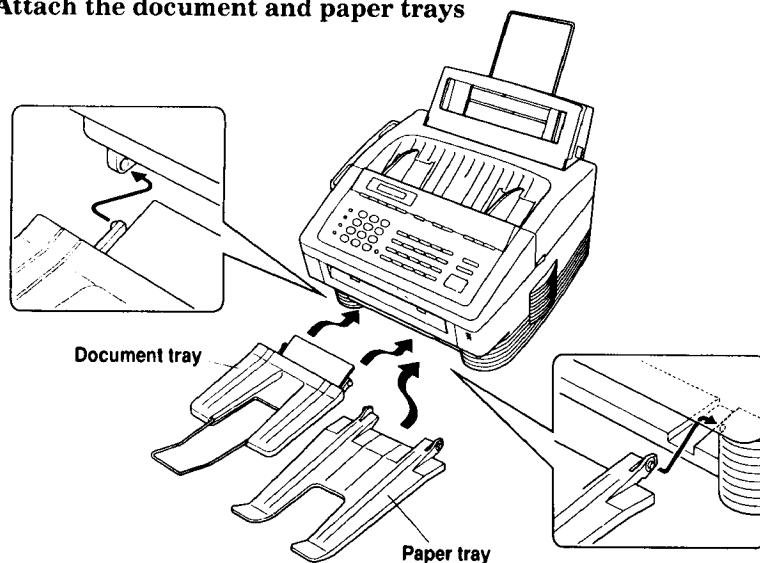

## MECHANICAL SETTINGS

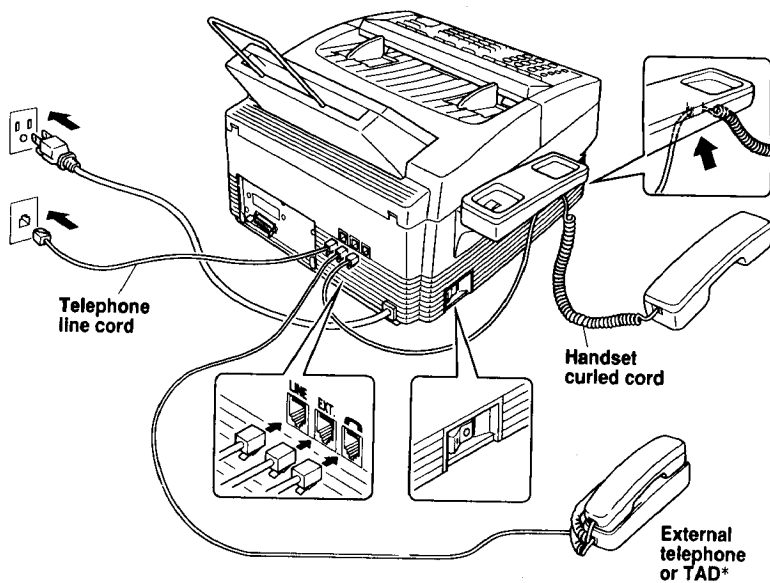

\* TAD: Telephone Answering Devices

- 2) **Connect the handset.**
- 3) **Connect the power cord and turn on the power switch that is located on the left side of your machine.**

When you turn on the power switch, the display will show "01/01/1997 00:00".

Make sure the machine automatically ejects the starter sheet while the machine is warming up immediately after installing a new drum unit.

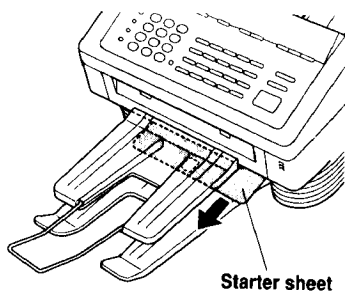

### NOTICE

1. This machine must be grounded using a 3-prong plug.
2. Since the machine is grounded through the power outlet, you can protect yourself from potentially hazardous electrical conditions on the telephone network by plugging in the power cord before you connect it to the telephone line.

Similarly, you can protect yourself when you want to move your machine, by disconnecting the telephone line first, and then the power cord.

#### 4) Connect the telephone line to the LINE jack.

### D. Connecting the MFC to the Computer

You must connect the MFC to your computer with the bidirectional IEEE 1284 compliant parallel cable that is included, unless you are using the optional serial interface board.

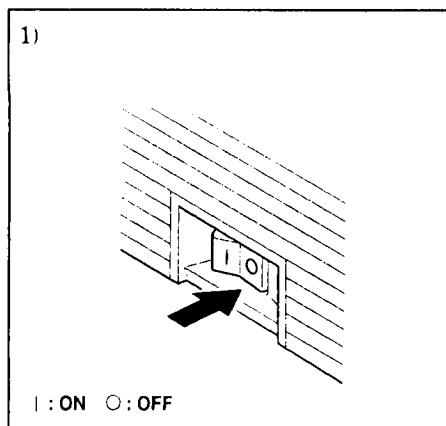

- 1) Make sure the power switch is off before connecting or disconnecting the interface cable.

Also, make sure the computer is turned off.

## MECHANICAL SETTINGS

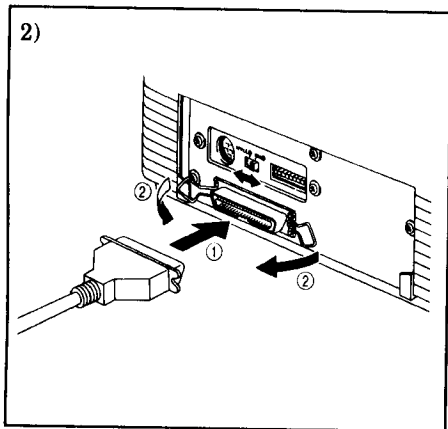

2) Connect the parallel interface cable to the parallel interface port of the MFC machine. (①)

Secure the connection with the wire clips. (②)

Connect the interface cable to the printer port of the computer.

### NOTE

You can use the optional RS-232C/RS-422A serial interface board (Part No.:RS100M). However, installing the RS100M optional interface board will not allow PC faxing and scanning on an Apple Macintosh computer.

For the location of your computer's parallel (or serial, if you are using the optional interface board) printer port, see the User's Guide for your computer.

## E. Connecting a Telephone Answering Device (TAD)

### *Hooking Up the Telephone Answering Device*

There is only one way you can hook up a Telephone Answering Device (TAD) on the fax phone line. **The TAD must be plugged into the back of the MFC machine in the jack labeled EXT.** Your MFC machine can not work properly if you plug the TAD into a wall jack. Follow these steps:

1. Plug the telephone line cord from the wall jack into the back of the MFC machine in the jack labeled **LINE**.
2. Plug the telephone line cord from your TAD into the back of the MFC machine in the jack labeled **EXT**. (Double check that the telephone line cord comes from the jack in the TAD for telephone line and not for telephone set.)

Please review the operation and receiving mode sections for more details on using Telephone Answering Devices (TAD).

(See "Operations Manual for Fax, Printer, Copier page 6-17~20.)

# MECHANICAL SETTINGS

## If your machine is MFC 4550:

You can change the answer mode by pressing the answer Mode key on the control panel.

### 1. Change the Answer Mode to TAD Mode.



Mode



Press Mode until both the Fax and F/T lights are lit.

### 2. Set up Your TAD.

## If your machine is MFC 6550MC/7550MC:

### 1. Change the Answer Mode to MSG CTR Mode.



Mode



Press Mode until both the Fax and F/T lights are lit.

### 2. Set up Your TAD.

## ***Recording the TAD's Outgoing Message (OGM)***

---

The TAD's outgoing message is important because it must be set up to handle two kinds of fax receptions: automatic and manual. Timing is important.

1. Record 5 seconds of silence as the beginning of your message. (Your MFC machine will be able to hear the fax calling tones, of automatic fax transmissions, before they stop.)
2. Limit your speaking to 20 seconds.
3. End your 20 second message by giving your Remote Activation Code for people sending manual faxes:  
"After the beep, leave a message or send a fax by pressing \*51."

**NOTE:** Do not assume that most callers send faxes automatically. Many people do not realize they are not sending fax tones when they lift the handset or press the Hook key. Also, some machines may not send fax tones.

## F. Connecting to Different Types of Phone Lines

### FOR YOUR INFORMATION

#### *Roll Over Phone Lines*

A roll over phone system is a group of two or more separate telephone lines that pass incoming calls to each other if they are busy. The calls are usually passed down or “rolled over” to the next available phone line in a preset order.

**Your MFC can work in a roll over system as long as it is the last number** in the sequence so the call can not roll away. Do not put the MFC on any of the other numbers. When the other lines are busy and a second fax call is received, the fax call is transferred to a line that does not have a MFC.

#### *Two Line Phone System*

A two line phone system is nothing more than two separate phone numbers on the same wall outlet. The two phone numbers can be on separate jacks (RJ11) or combined into one jack (RJ14). Your MFC must be plugged into an RJ11 jack. RJ11 and RJ14 jacks may be equal in size and appearance and both may contain 4 wires (black, red, green, yellow). To test the type of jack, plug in a two line phone and see if it can access both lines. If it can, you must separate the lines for your MFC.

#### *Converting Telephone Wall Outlets*

There are three ways to convert to an RJ11 receptacle. The first two ways may require assistance from the telephone company. You can change the wall outlet from one RJ14 jack to two RJ11 jacks. Or, you can have an RJ11 wall outlet installed and slave or jump one of the phone numbers to it. The third way is the easiest. Buy a triplex adapter.

You can plug a triplex adapter into an RJ14 wall outlet. It will separate the wires into two separate RJ11 jacks (line 1, line 2) and a third RJ14 jack (lines 1 and 2). Plug the fax machine into L2 of the triplex adapter.

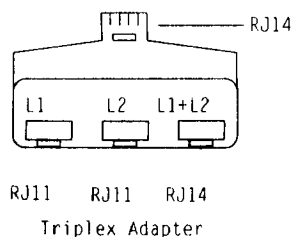

## FOR YOUR INFORMATION

***Installing a MFC, Two Line TAD and Two Line Telephone***

When you are installing a two line telephone answering device (TAD) and a two line telephone, your MFC must be isolated on one line at both the wall jack and at the TAD. The most common connection is to put the fax machine on line 2. The back of the two line TAD must have two telephone jacks: one labeled L1 or L1 and L2 and the other labeled L2. You will need at least three telephone line cords: the one that came with your MFC and two for your two line TAD. You will need a fourth line cord if you add a two line telephone.

Place the two line TAD and two line telephone beside your MFC. Plug one end of the telephone line cord for your MFC into the L2 jack of the triplex adapter; plug the other end into the LINE jack in the back of the MFC. Plug one end of the first telephone line cord for your TAD into the L1 jack of the triplex adapter; plug the other end into the L1 or L1 and L2 jack in the back of the two line TAD. Plug one end of the second telephone line cord for your TAD into the L2 jack in the back of the two line TAD; plug the other end into the EXT jack in the back of the MFC. The two line TAD hookup is complete. It will answer both lines as usual.

You can keep two line telephones on other wall outlets as always. There are two ways to add a two line telephone to the MFC's wall outlet. Plug the telephone line cord from the two line telephone into the L1+L2 jack of the triplex adapter. If you prefer, you can plug it into the TELE jack in the back of the two line TAD instead.

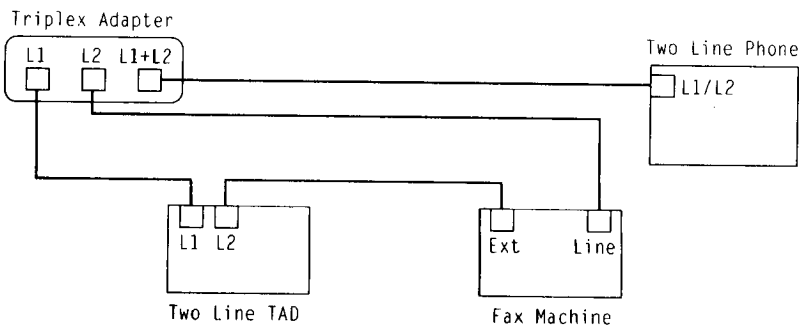

## FOR YOUR INFORMATION

### ***Connecting Your Machine to a Multi Line system (PBXs)***

Most offices use a central telephone system. While it is often relatively simple to connect the machine to a key system or a PBX (private branch exchange), we suggest that you contact the company that installed your telephone system and ask them to connect the machine for you.

It is advisable to have a separate line for the machine. You can then leave the machine in Fax Mode to receive faxes at any time of the day or night.

If the machine is to be connected to a multi-line system, ask your installer to connect the unit to the last line on the system. This will prevent the unit from being activated each time a telephone call is received.

- As with all fax units this machine must be connected to a two wire phone system. If your line has more than two wires, proper connection of the machine can not be made.

### ***Connecting to a Private Branch Exchange***

The following points should be kept in mind if you are installing the machine to work with a private branch exchange(PBX).

- 1)It is not guaranteed that the unit will operate correctly under all circumstances with PBXs. Any cases of difficulty should be reported first to the company that handles your PBX.
- 2)If all incoming calls will be answered by a switchboard operator, it is recommended that the Answer Mode be set to Manual. (See page 6-1~2 of the Operations Manual.) All incoming calls should initially be regarded as telephone calls.
- 3)The unit may be used with either pulse or tone dialing telephone types.

### ***Custom Features on Your Phone Line***

If you have Call Waiting, Ring Master, Voice Mail, an Answering Service, Alarm System or any other custom calling feature on your telephone line, it may create a problem in operation of your MFC.

### 3. SOFTWARE SETTINGS

#### A. TELEPHONE FUNCTION SETTINGS

There are some settings, such as the date and time, you should set on your machine before you begin using it. Once entered, these settings will remain in the machine until you change them. You can begin customizing the settings by pressing **Function** on the control panel. This activates the function mode and On-Screen Programming prompts. You can complete a variety of settings in this mode.

(This chapter (TELEPHONE FUNCTION SETTINGS) is also inserted in the Operations Manual. Please refer to the Operations Manual page 3-1~11 for more information.)

#### Setting the Dialing Mode (Tone/Pulse)

Your machine supports both tone (multi-frequency) and pulse (rotary) dialing. It is initially set to TONE, so you do not have to change the setting if you use that kind of line. If you are using a pulse dial line, you can change the setting to PULSE by following the steps below:

#### KEYS TO PRESS

#### THE DISPLAY WILL SHOW:

1. Press **Function**.

You will see scrolling options on the display. You can choose one.

(The MFC 4550 will skip to Step 4.)

2. Wait for two seconds.

(Only for MFC 6550MC/7550MC)

3. Press **1**.

(Only for MFC 6550MC/7550MC)

4. Press **6**.

5. Press **1**.

After two seconds you will be prompted to select pulse or tone.

6. Press ◀ (left arrow) or ▶ (right arrow) to find the dialing mode that matches your telephone line.

Example: PULSE.

01/01/1997 00:00  
ONLINE

ENTER NO. & SET

(Only for MFC  
6550MC/  
7550MC)

1. FAX  
2. PRINTER

(Only for MFC  
6550MC/  
7550MC)

1. FAX

6. TEL OPTIONS

1. TONE/PULSE

DIALING: TONE

SELECT ◀ ▶ & SET

DIALING: PULSE

# SOFTWARE SETTINGS

7. Press **Set**.

1. TONE/PULSE

8. Press **Stop** to return to the date and time.

## *Setting the Date and Time*

Your machine shows the date and time on the display and prints it on every fax page you send. You can set the date and time in function mode.

### KEYS TO PRESS

1. Press **Function**.  
(The MFC 4550 will skip to Step 4.)

2. Wait for two seconds.  
(Only for MFC 6550MC/7550MC)

3. Press **1**.  
(Only for MFC 6550MC/7550MC)

4. Press **7**.

5. Press **1**.

6. Enter the last two digits of the year.  
Example: **96**.

7. Enter two digits for the month. (JAN = 01, OCT = 10, etc.)  
Example: **09**.

8. Enter two digits for the day.  
Example: **12**.

### THE DISPLAY WILL SHOW:

01/01/1997 00:00  
ONLINE

ENTER NO. & SET

(Only for MFC 6550MC/7550MC)  
1. FAX  
2. PRINTER

(Only for MFC 6550MC/7550MC)  
1. FAX

7. SETUP SYSTEM

1. DATE/TIME

ENTER YEAR: XX

ENTER YEAR: 96

ENTER MONTH: XX

ENTER MONTH: 09

ENTER DAY: XX

ENTER DAY: 12

ENTER TIME: XX:XX

# SOFTWARE SETTINGS

9. Enter the time in 24-hour format.

Example: **15:25** (3:25 P.M.).

ENTER TIME: 15:25

10. Wait for two seconds.

1. DATE/TIME

11. Press **Stop** to exit and to view the new date and time.

09/12/1996 15:25  
ONLINE

## Setting the Station ID

The Station ID is for identification purposes. Here you can store your name, fax number, and telephone number. Your machine prints this information on the electronic Cover Page and every fax page you send.

### KEYS TO PRESS

### THE DISPLAY WILL SHOW:

1. Press **Function**.

(The MFC 4550 will skip to Step 4.)

09/12/1996 15:25  
ONLINE

ENTER NO. & SET

2. Wait for two seconds.

(Only for MFC 6550MC/7550MC)

(Only for MFC  
6550MC/  
7550MC)

1. FAX  
2. PRINTER

3. Press **1**.

(Only for MFC 6550MC/7550MC)

(Only for MFC  
6550MC/  
7550MC)

1. FAX

4. Press **7**.

7. SETUP SYSTEM

5. Press **4**.

You will then be prompted to enter your fax number.

4. STATION ID

FAX:

ENTER & SET

6. Enter your fax number (up to 20 digits).

Example: **4155554444**.

FAX: 4155554444\_

7. Press **Set**.

You will be prompted to enter your telephone number.

TEL:

ENTER & SET

# SOFTWARE SETTINGS

8. Enter your telephone number (up to 20 digits).

If your telephone number and fax number share the same line, enter the same number again.

Example: **4155554445**.

TEL:4155554445\_

9. Press **Set**.

You will be prompted to enter your name or company's name.

NAME:

ENTER & SET

10. Enter your name by using the number keys (up to 20 characters).

Example: **BROTHER**.

NAME: BROTHER

By pressing the appropriate number key the correct number of times, you can access the character you want. For example, press 2 twice to enter B.

Refer to the section "How to Enter Text in Function Mode" on pages 2-10~12 in the Operations Manual.

11. Press **Set** to confirm the entry.

4. STATION ID

12. Press **Stop** to return to the date and time.

## Helpful Hints

- The telephone number that you stored above is used only for the Call Back Message and the Cover Page features.
- If you do not enter a fax number, no additional information can be entered.
- When you want to enter a blank space, use ► (right arrow). You can back up to change entries by using the ◀ (left arrow).
- If the Station ID was programmed, then after Step 5 the name will be displayed with the prompt "1" to change "2" to exit. Press "1" to change information. Press "2" to exit from the function.

## NOTICE

The Telephone Consumer Protection Act. of 1991 makes it unlawful for any person to use a computer or electronic device to send any message via a telephone fax machine unless such messages clearly contain in a margin at the top or bottom of each transmitted page or on the first page of the transmission, the date and time it is sent and an identification of the business or other entity, or other individual sending the message and the telephone number of the sending machines or such business, other entity, or individual.

To program this information into your machine, complete the steps on the previous page.

***Setting the Beeper Volume Level***

If the beeper setting is LOW or HIGH, it will “beep” every time you press a key, make an error, or at the end of sending or receiving a fax.

The initial setting on your machine for the beeper is LOW. If you do not want the beeper on, select OFF, and if you want it loud, select HIGH.

**KEYS TO PRESS**

1. Press **Function**.  
(The MFC 4550 will skip to Step 4.)
2. Wait for two seconds.  
(Only for MFC 6550MC/7550MC)
3. Press **1**.  
(Only for MFC 6550MC/7550MC)
4. Press **5**.
5. Press **2**.
6. Press ◀ (left arrow) or ▶ (right arrow)  
until you get the setting you want.  
Example: OFF.

**THE DISPLAY WILL SHOW:**

09/12/1996 15:25  
ONLINE

ENTER NO. & SET

(Only for MFC 6550MC/7550MC)  
1. FAX  
2. PRINTER

(Only for MFC 6550MC/7550MC)  
1. FAX

5. USER OPTIONS

2. BEEPER

BEEPER: LOW

SELECT ◀ ▶ & SET

BEEPER: OFF

# SOFTWARE SETTINGS

7. Press **Set**.

2. BEEPER

8. Press **Stop** to return to the date and time.

## Storing the One-Touch Dial Numbers

You can dial numbers automatically by storing telephone or fax numbers as One-Touch dial numbers. You can also store names with the numbers so when you call, you can verify the destination by the name on the display. You can store a maximum of 24 numbers. To access numbers 13 to 24, hold down the **Shift** key. For example, One-Touch location "13" is accessed by pressing **Shift + One-Touch "01"** simultaneously. Here is how to store a telephone number as a One-Touch dial number:

### KEYS TO PRESS

1. Press **Function**.  
(The MFC 4550 will skip to Step 4.)
  2. Wait for two seconds.  
(Only for MFC 6550MC/7550MC)
  3. Press **1**.  
(Only for MFC 6550MC/7550MC)
  4. Press **4**.
  5. Press **1**.
  6. Press the **One-Touch** key where you want to store a number.  
Example: **One-Touch 05**.
- Note: The One-Touch keys are not the number keys.
7. Enter a number (up to 20 digits).  
Example: **14155551212**.

(Only for MFC  
6550MC/  
7550MC)

(Only for MFC  
6550MC/  
7550MC)

### THE DISPLAY WILL SHOW:

09/12/1996 15:25  
ONLINE

ENTER NO. & SET

1. FAX  
2. PRINTER

1. FAX

4. SET AUTO DIAL

1. ONE-TOUCH DIAL

SELECT ONE-TOUCH

\*05:

ENTER & SET

\*05:14155551212\_

## SOFTWARE SETTINGS

8. Press **Set**.

You then will be prompted to enter the name or company associated with this number.

9. Enter the name by using the number keys (up to 15 characters).

Example: **NJ OFFICE**.

(See page 2-10~12 of the Operations Manual for how to enter text.)

10. Press **Set**.

11. Select the type of number (FAX, TEL, F/T, CHAIN) after using ◀ (left arrow) or ▶ (right arrow) to display the type you want.

(See For Your Information on page 3-11 of the Operations Manual.)

Example: **FAX**.

12. Press **Set**.

13. Return to Step 6 to enter another number, or press **Stop** to return to the date and time.

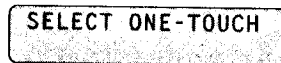
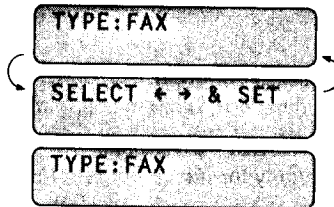
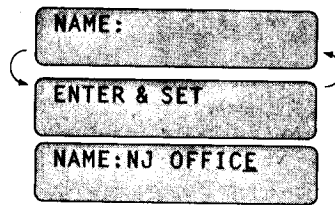

### Helpful Hints

If you must wait for a dial tone to access an outside line, insert a pause by pressing the **Redial/Pause** key. When you press **Redial/Pause**, a dash "-" will appear on the display. By storing the numbers with a pause, you can create a delay of 3.5 seconds.

## Storing the Speed-Dial Numbers

When you store a phone or fax number as a Speed-Dial number, you must enter a **two-digit number**, from 01 to 00 (00=100) (MFC 7550MC) and from 01 to 36 (MFC 4550/6550MC) using the number keys. For example, you can not enter "5". You must enter "05". You can store as many as 100 numbers (MFC 7550MC) or 36 numbers (MFC 4550/6550MC) as Speed-Dial numbers.

### KEYS TO PRESS

1. Press **Function**.  
(The MFC 4550 will skip to Step 4.)
2. Wait for two seconds.  
(Only for MFC 6550MC/7550MC)
3. Press **1**.  
(Only for MFC 6550MC/7550MC)
4. Press **4**.
5. Press **2**.
6. Use the number keys to enter a two-digit number.  
Example: **05**.
7. Enter the number (up to 20 digits).  
Example: **5555151**.
8. Press **Set**.  
You then will be prompted to enter the name or company associated with this number.
9. Use the number keys to enter a name (up to 15 characters).  
Example: **MANCHESTER**.  
(See page 2-10~12 of the Operations Manual for entering text.)

### THE DISPLAY WILL SHOW:

09/12/1996 15:25  
ONLINE

ENTER NO. & SET

(Only for MFC 6550MC/7550MC)  
1. FAX  
2. PRINTER

(Only for MFC 6550MC/7550MC)  
1. FAX

4. SET AUTO DIAL

2. SPEED-DIAL

SPEED-DIAL? #\_

SPEED-DIAL? #05

#05:

ENTER & SET

#05:5555151\_

NAME:

ENTER & SET

NAME:MANCHESTER

## SOFTWARE SETTINGS

© 2000 NEC Electronics Corporation

10. Press **Set**.

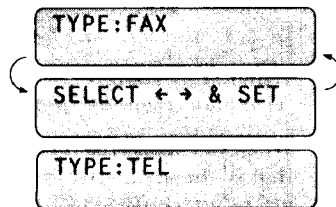

11. Select the type of number (FAX, TEL, F/T, CHAIN) by using ◀ (left arrow) or ▶ (right arrow) to display the type you want.

Example: TEL.

(See Operations Manual page 3-11.)

12. Press **Set**.



13. You are ready to enter another Speed-Dial number, or press **Stop** to return to the date and time.

- Helpful Hints**
- Print the All Dial List to make sure you have stored the correct numbers. (See page 11-3~4 of the Operations Manual.) This list will contain the type of number: FAX, TEL, F/T, or CHAIN.
  - **Even if there is a loss of electrical power to unplug your machine, the telephone and fax numbers you have stored will not be lost.**
  - If your machine is connected to a PBX, you must insert an additional number before each fax or telephone number to access an outside line.

## FOR YOUR INFORMATION

***When You Wish to Change the Stored One-Touch and Speed-Dial Numbers (During Step 6 on Page 3-6, 8)***

When you access the function for a One-Touch key or Speed-Dial number, that is already in use, you will be asked if you wish to change it or to exit and select a different One-Touch or Speed-Dial number. This display does not appear if the One-Touch key or Speed-Dial number you chose is not assigned.

1. Press **1** to assign a new number to the One-Touch key or Speed-Dial number, or press **2** to choose a different One-Touch key or Speed-Dial number.

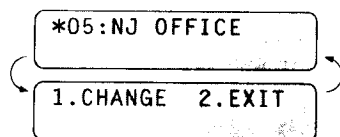

2. If you are replacing an existing number with a new one, the old number and name will appear in the display. Press **Clear** to erase the old number and name. Then, enter the new number and name and press **Set** to store the entry.

***Memory Storage/Temporary Battery Back Up***

Your machine is equipped with an internal battery that will keep the date and time information for up to two hours after power has been cut off. After that time, the date and time will be lost and you will have to reenter the information. All other settings in the SET AUTO DIAL, USER OPTIONS and SETUP SYSTEM functions (See the Operations Manual page 2-3~6) are stored permanently and will be retained even in the event of a power failure. However, the data stored in the memory during Out-of-Paper Reception and Memory Transmission will be lost when the power is disconnected.

***Setting Up Number Groups for Broadcasting***

Number Groups allow you to send the same fax message to many fax numbers by pressing only one One-Touch key. (This is called Broadcasting.) You must store each fax number first as a One-Touch or Speed-Dial number. Then you can combine the stored numbers into a Group.

You can have up to 6 smaller Groups (each group uses a One-Touch key) or you can assign up to 123 numbers (MFC 7550MC) and 59 numbers (MFC 4550/6550MC) if you want one large Group. You can use the same stored number in several groups. Groups can have a name up to 15 characters long.

**KEYS TO PRESS**

1. Press **Function**.  
(The MFC 4550 will skip to Step 4.)
2. Wait for two seconds.  
(Only for MFC 6550MC/7550MC)
3. Press **1**.  
(Only for MFC 6550MC/7550MC)
4. Press **4**.
5. Press **3**.
6. Press the One-Touch key where you wish to store the number.  
Example: select "One-Touch 02" as a group.
7. After two seconds, enter a number for the group using the number keys.  
Example: 1.

**THE DISPLAY WILL SHOW:**

09/12/1996 15:25  
OFFLINE

ENTER NO. & SET

(Only for MFC 6550MC/7550MC)  
FAX  
2. PRINTER

(Only for MFC 6550MC/7550MC)  
1. FAX

4. SET AUTO DIAL

3. SETUP GROUPS

SELECT ONE-TOUCH

SETUP GROUP:G0

ENTER & SET

SETUP GROUP:G01

G01:

ENTER & SET

## SOFTWARE SETTINGS

8. Enter the One-Touch or Speed-Dial numbers in this group.

Example: #03, #05, \*02

(Note: Press the Speed-Dial key and number keys for Speed-Dial numbers, and the One-Touch keys for One-Touch numbers.)

G01:#03#05\*02\_

\*...One-Touch  
#...Speed Dial

9. Press **Set**.

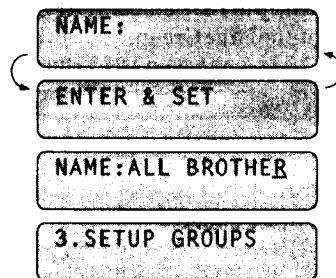

10. Enter the group's name.  
Example: **ALL BROTHER**.

11. Press **Set**.

12. Press **Stop** to return to date and time.

**Helpful Hints** You can print a list of all One-Touch numbers and Speed-Dial numbers. Group numbers will be listed under One-Touch numbers. (See page 11-5 of Operations Manual.)

**B. MULTI-FUNCTION LINK PRO SOFTWARE SETTINGS****1) FOR WINDOWS® USERS*****Setting Up Windows® 95 for the MFC***

You must configure Windows® 95 for the MFC by installing the Multi-Function Link Pro software disk, which includes TrueType™-compatible fonts:

1. Make sure the MFC is connected to your computer.
2. Turn on your MFC.
3. Turn on your computer and start Windows® 95. The screen on the right will appear.

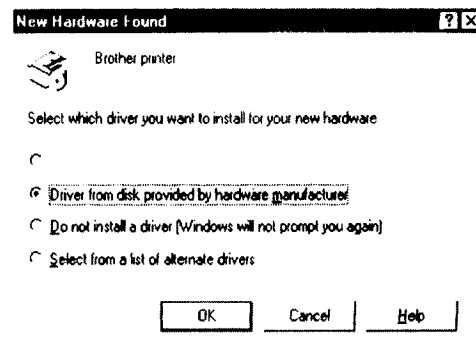
**NOTE**

If Windows® 95 does not recognize your MFC:

1. Click the Start button and choose Run.
  2. Insert the Printer driver disk for Windows® into your floppy disk drive.
  3. Type A: SETUP and click the OK button or press the Enter key.
- After the installer starts, you may skip the following steps and simply follow the instructions that appear on the screen.
4. Make sure the second button “Driver from disk provided by hardware manufacturer” is checked.

5. Click the OK button. The screen on the right will appear.

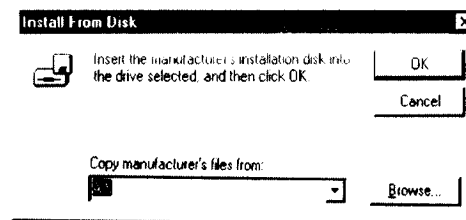

# SOFTWARE SETTINGS

6. Insert the supplied disk for Windows® 95 into the floppy disk drive (usually drive A).

## NOTE

To install from another drive, type the drive name in the “Copy manufacturer’s files from” box on the screen.

7. Click the OK button.
8. Follow the instructions that appear on the screen.

## *Setting Up Windows® 3.1 for the MFC*

---

You must configure Windows® 3.1 for the MFC by installing the Multi-Function Link Pro Software, which includes TrueType-compatible fonts.

Because the supplied printer driver and fonts are compressed on the disk, be sure to use the Brother installer to install them. We assume you will install the driver and fonts from the **A DRIVE**.

1. Start Windows® 3.1.
2. Insert the Brother disk for Windows® into your floppy disk drive.
3. Choose the **Run** command from the **File** menu in the Program Manager.
4. Type the drive name where you inserted the disk and “SETUP” in the box: for example, **A:\SETUP**. Choose the OK button or press the **Enter** key.

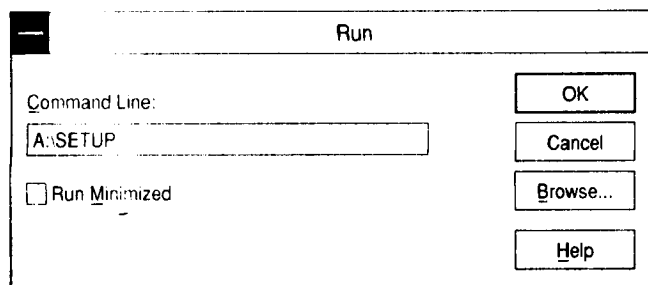

5. The installer will start running. Follow the instructions on the computer screen.

- Helpful Hints**
- The installer automatically updates your **SYSTEM.INI** Windows® file by adding **DEVICE=bi-di.386** under the **[386Enh]** section. If any bidirectional parallel communications device driver has previously been installed, it will be deactivated by this new driver. If you want to use the driver that was previously installed, you should first install this driver, then reinstall your previous driver. However, reinstalling the previous driver will make the MFC driver inactive.
  - The installer makes the installed printer driver the Windows® default.
  - The installer automatically sets the printer port to the parallel interface, **LPT1**.
  - During this installation, changes have been made to the **SYSTEM.INI** file. It is necessary to restart Windows® so that the changes become effective and the installed bidirectional parallel communications device driver can take effect.

## 2) FOR DOS USERS (Only for MFC 6550MC/7550MC)

### How to Use the MFC with Your DOS Application Software

Before working with your application software that runs on DOS or Windows MS-DOS Prompt, check that the machine's name (MFC) appears in the printer selection of your application software. If the MFC is not listed, you must install the printer driver that corresponds to HP LaserJet IIP's emulations.

The following table shows combinations of printer drivers and emulation mode. To get the most out of this machine, you should install an HP printer driver in your application software.

Printer driver supported in your application software	Emulation mode to be selected with the remote printer console program
<b>HP LaserJet IIP™</b> HP LaserJet II™	HP LaserJet IIP emulation mode Auto emulation selection

- Helpful Hints**
- The best or recommended printer driver is indicated in bold.
  - Be sure to choose the proper printer driver in your application software.
  - Be sure the printing resolution is set to 300 dpi in your DOS application software.

## ***What Does the Remote Printer Console Do?***

---

The Remote Printer Console (RPC) is a utility program that can run in the DOS environment and comprises the following two programs:

### **Remote Printer Console Main Program**

This program allows you to change various printer settings such as emulation, print quality, fonts, page setup etc., from your computer screen. Since most DOS applications have a printer settings menu that overrides the settings made by the RPC, you may not have to use this utility program. This utility program is useful for application software that does not control the printer's settings and features.

### **Printer Status Monitor Program**

This utility program can monitor your printer's status using bidirectional parallel communications. If your MFC has no paper, this utility program displays "Paper Empty" error status and instructions for corrective action on your computer screen. This utility program stays resident in your computer memory (Terminate-and-Stay Resident program) and runs in the background.

## ***Installing the Remote Printer Console***

---

Before you install the program, make sure you have the following hardware and software to install the program:

DOS	Version 3.3 or later
Monitor	EGA/VGA or compatible
Option	Mouse; the mouse driver must be installed. (You can also operate the program with the keyboard.)

Follow these steps to install the remote printer console program:

1. Make sure your MFC is connected to your computer and it is set to on-line.
2. Start your computer and go to the DOS prompt. If you are in Windows®, exit and return to the DOS prompt.
3. Insert the supplied disk into your floppy disk drive (A: or B:).

4. Select drive A or B to be used by typing **A:** or **B:** after the DOS prompt and then press the Enter key.

```
C:\>A:
```

5. Type **RPCSETUP** and press the Enter key.

```
A:\>RPCSETUP
```

6. Follow the instructions from the installer.

### ***Using the Remote Printer Console Main Program***

Type **C:\RPCX>RPCX** and press the Enter key to start the Remote Printer Console main program.

The Main Screen will appear on your computer screen as shown below.

```

Remote Printer Console
-----
Direct_Access  Printer_Setup  Console_Config  Guide
-----
Current Status
-----
Status          Ready
Paper feed      Sheet Feeder
Emulation       PCL
Paper Size      Letter
Orientation     Portrait
Quality         Normal
Copies          1
Memory size     524288 Byte
-----
[↑/~] Select  [Enter] Setting
-----
[Alt+Character] Menu  [F1] Help  [ESC] Exit

```

The RPC gets the current settings information from your MFC when it starts if bidirectional communication is enabled between your computer and MFC. Otherwise, RPC shows its default settings. If you want to change settings, move the cursor to the item you want and select it using the **Enter** and **Cursor** keys. Then, press the **Enter** key to make the selected setting valid.

# SOFTWARE SETTINGS

There are four sub menus (see table below). Select the sub menu you want by clicking on it with the mouse, using the cursor keys and the **Enter** key, or by pressing the hot key commands for that sub menu.

Menu	Press the keys	Functions
Direct	<b>Alt + D</b>	You can directly control the MFC, with Print Form, Self Print, Reset Printer.
Printer Setup	<b>Alt + P</b>	You can enter the setting mode to change other printer settings, such as, margin settings, continue mode, reprint function, font and sleep mode.
Console Config	<b>Alt + C</b>	You can change the environment settings for the RPC program: color, Status Monitor configuration, etc.
Guide	<b>Alt + G</b>	You can go to the Guide mode.
Help	<b>F1</b>	You can get Online Help: If you press F1, you can get information on a highlighted item.

## *Remote Printer Console*

### Current Printer Status Information

Item	Default	What This Item Does
Paper Feed*1	Sheet Feeder	Selects the paper feed method "Sheet Feeder" or "Manual".
Emulation*1	Laser Jet IIP	"Laser Jet IIP".
Paper Size*1	Letter	Selects the paper size from "A4", "Letter", "Legal", "B5", "DL", "JIS B5", "Executive", "COM10", "Monarch" or "C5."
Orientation*1	Portrait	Selects the paper direction, either "Portrait" or "Landscape."
Quality*1	Normal	Selects the print quality, either "Normal" or "Economy."
Copies*1	1	Sets the number of print copies from 1 to 200 pages.
Memory size*2		RPC retrieves and displays the printer memory size.

\*1 The items can be set in the current printer status information dialog box.

\*2 The information above is displayed if the bidirectional communication is active between the computer and MFC.

**Printer Setup Category****Print Setup Section**

Item	Default	What This Item Does
Copy Pages	1	Sets the number of print copies from 1 to 200 pages.
Quality	Normal	Selects the print quality to either "Normal" and "Economy".
Emulation	Laser Jet IIP	Laser Jet IIP
Time out	5 sec	In "Auto" emulation mode, sets a time-out value of 1 to 99 seconds.
Auto FF	Off	If set to ON, the printer will print the remaining data automatically without your pressing the FF/CONT key.
Auto FF Timeout	5 sec	Sets the time-out value for the Auto FF mode from 1 to 99 seconds.

**Page Setup Section**

Item	Default	What This Item Does
Paper size*1	Letter	Selects the paper size from "A4", "Letter", "Legal", "B5", "DL", "JIS B5", "Executive", "COM10", "Monarch", or "C5."
Orientation*1	Portrait	Selects the paper direction to either "Portrait" and "Landscape."
Left Margin	*2	Sets the Left Margin value (0-126) columns
Right Margin	*2	Sets the Right Margin value (0-136) columns
Top Margin	0.5" or 0.33"	Sets the Top Margin 0", 0.33", 0.5", 1", 1.5" or 2".
Bottom Margin	0.5" or 0.33"	Sets the Bottom Margin 0", 0.33", 0.5", 1", 1.5" or 2".
Line / Page	*2	Sets the lines/pages (5-128).
Xoffset	0	Sets the Xoffset (vertical) value from -500 to 500 dots.
Yoffset	0	Sets the Yoffset (horizontal) value from -500 to 500 dots.

\*1 These values (except Yoffset and Xoffset) are overridden by settings within your application software.

\*2 These values depend on the emulation/paper size settings.

# SOFTWARE SETTINGS

## Font Config

Item	Default	What This Item Does
Font Source	Internal*1	Selects the font source between “Internal” and “Permanent.”
Font name	Brogam10	Selects a font from any of the printer’s internal or permanent downloaded fonts.
Pitch	10	Selects the font size of the selected font. If you selected the Brougham or LetterGothic font, Pitch is shown in the selection box.
Symbol Set	*2	Selects the symbol set.

\*1 This setting is valid only when the emulation is set to HP LaserJet IIP.

\*2 This setting varies according to the emulation setting.

## Printer Config

Item	Default	What This Item Does
Continue Mode	Manual	Selects Auto or Manual on Auto error recovery mode.
Parallel High Speed	Valid	Selects the parallel high speed “Valid” or “Invalid”.
Reprint	Valid	Sets the reprint function “Valid” or “Invalid”.

## Other Config

Item	Default	What This Item Does
Auto LF	Off	Selects Auto LF “On or Off”
Auto CR	Off	Selects Auto CR “On or Off”
Auto Wrap	Off	Selects Auto Wrap “On or Off”
Auto Skip	On	Selects Auto Skip “On or Off” (Only for HP Emulation)
Auto Mask	Off	Selects Auto Mask “On or Off” (Only for IBM an Epson Emulation)

File	Function
Send settings	Sends the settings made within the RPC to your machine (MFC).
Load settings	Loads the settings you stored in your disk or hard disk to the RPC.
Save settings	Saves the RPC settings to your disk or hard disk.
Save As command	Saves the RPC settings to your disk or hard disk as a printer command string.
Load Default setting	Loads the default settings to RPC.

### Direct Access Category

Item	Function
Print Form	Prints the MFC's character/symbol sets "CHARASET.PRN" or any print files you have made.
Self Print	Executes the MFC's self test.
Reset Printer	Resets the MFC. The data remaining in the MFC and the printer settings will be cleared.

### Console Config Category

Item	Function
Environment	Sets the Printer Port, Buzzer on/off, Color for Remote Print Console
Status Monitor	Sets the hot-key for waking-up the RPC.

For more information on RPC, see the Help Information within the program.

### *Using the Printer Status Monitor Program*

Type **C:\RPCX>STMX** and press the **Enter** key to make the Printer Status Monitor Program stay resident in your computer memory. If there are any changes to the printer status, it displays a message on your computer screen.

If the Printer Status Monitor program stays resident in your computer, you can monitor the printer status on your computer screen immediately by using the hot-key (**Ctrl+Alt+R**).

To remove the Printer Status Monitor program from your computer memory, type **C:\RPCX>STMX/R** and press the **Enter** key.

## SOFTWARE SETTINGS

### Helpful Hints

- The RPC works in the environment where your MFC is directly connected to your computer. If you are using any printer buffer switches that do not support bidirectional communication between the MFC and computer, the program works only in the PC to MFC direction and can not receive MFC status information.
- The program does not work with MFCs on a network.
- If the RPC conflicts with some application software, exit your application software and then run the RPC.
- The RPC may work in the DOS-compatible box screen mode of Windows®. However, it is recommended that you completely exit from Windows® to the DOS prompt before using the RPC.
- The Printer Status Monitor and some other Terminate-and-Stay programs can not coexist in the computer's memory. If they don't work properly together, use them one at a time. You can suspend the Printer Status monitor with any of the following methods or commands.

Type **C:\RPCX>STMX/R** and press the **Enter** key. Hold the space bar down while executing the **AUTOEXEC.BAT** file at **DOS** startup to prevent the status monitor from being loaded as a TSR program.

**4. TEST YOUR MACHINE*****Print a Test Sample Page***

We recommend that you print a test page. Refer to the instructions below.

**KEYS TO PRESS**

1. Make sure the LCD displays "OFFLINE".  
If not, press **On/Off Line**.
2. Press **Test/Reset**.  
The machine will start printing a test sample page.

**THE DISPLAY WILL SHOW:**

09/12/1996 15:25  
ONLINE

09/12/1996 15:25  
TEST PRINT

09/12/1996 15:25  
ONLINE

**NOTICE**

If the machine does not print a test sample page exactly, see "page 10-1~14" of the Operations Manual. If after reviewing the information in the manual, you still can not print the test sample page exactly, consult your dealer.

If additional help is needed, please contact the Customer Service number in next Section.

***Send a Test Sheet by Fax***

Please fill out the TEST SHEET and fax it to **1-908-469-4547 (USA), 1-514-685-0702 (CANADA)** as your first transmission. This will verify that your MFC is properly installed.

When this document is received at Brother Diagnostic Center, a confirmation sheet will be sent back to your machine from Brother's Fax-Back<sup>SM</sup> System (USA only). Be sure to set up your "Station ID". (See page 4-3.)

**USA**

FAX NO. : **1-908-469-4547** (Fax Transmission Only)

TEL NO. : **1-800-284-4FAX** (Voice Phone Only)

**1-800-284-4329**

**CANADA**

FAX NO. : **1-514-685-0702**

TEL NO. : **1-800-853-6660, 8:00AM - 8:00PM E.S.T**

## 5. INDEX

- A**  
 Answer Mode ..... 2-9
- B**  
 Battery ..... 3-10  
 Beeper ..... 3-5~6
- C**  
 Connecting the MFC ..... 2-7~8  
 Connecting a TAD ..... 2-8~10  
 Converting Wall Outlet ..... 2-11
- D**  
 Date and Time ..... 3-2~3  
 DOS Users ..... 3-15~22  
 Drum Unit ..... 2-1~2  
 Dialing Mode ..... 3-1
- F**  
 Font Configuration ..... 3-20
- G**  
 Groups for  
 Broadcasting ..... 3-11~12
- I**  
 Installing the Drum Unit Assembly  
 ..... 2-1~2
- J**  
 Jacks ..... 2-11~12
- L**  
 Loading Paper ..... 2-2~4
- M**  
 Memory ..... 3-10  
 Multi Line Systems ..... 2-13  
 Multipurpose Sheet  
 Feeder ..... 2-2~4
- N**  
 Number Groups ..... 3-11~12
- O**  
 One-touch Dial ..... 3-6~7
- P**  
 Packing List ..... 1-2  
 PBXs ..... 2-13, 3-9  
 Power ..... 2-6, 2-7  
 Printer Configuration ..... 3-20  
 Printer Status Monitor ..... 3-21
- R**  
 Recording Paper Size ..... 2-4~5  
 Recording Paper Type ..... 2-4~5  
 Remote Printer Console .. 3-16~18  
 Roll Over Phone Lines ..... 2-11
- S**  
 Setting up the MFC ..... 2-5~7  
 SHIFT ..... 3-6  
 Speed Dial ..... 3-8~9  
 Station ID ..... 3-3~4
- T**  
 TAD ..... 2-8~10  
 Telephone Line  
 ..... 2-6, 2-7, 2-8, 2-11~12

# INDEX

Test Sample Page .....	4-1
Test Sheet .....	4-1
Tone/Pulse .....	3-1~2
Toner Cartridge .....	2-1
Two Line Phone System.....	2-11
Two Line TADs .....	2-12

## W

Windows® 3.1 .....	3-14~15
Windows® 95 .....	3-13~14



## Notice

BROTHER'S LICENSOR(S) MAKES NO WARRANTIES, EXPRESS OR IMPLIED, INCLUDING WITHOUT LIMITATION THE IMPLIED WARRANTIES OF MERCHANTABILITY AND FITNESS FOR A PARTICULAR PURPOSE, REGARDING THE SOFTWARE. BROTHER'S LICENSOR(S) DOES NOT WARRANT, GUARANTEE OR MAKE ANY REPRESENTATIONS REGARDING THE USE OR THE RESULTS OF THE USE OF THE SOFTWARE IN TERMS OF ITS CORRECTNESS, ACCURACY, RELIABILITY, CURRENTNESS OR OTHERWISE. THE ENTIRE RISK AS TO THE RESULTS AND PERFORMANCE OF THE SOFTWARE IS ASSUMED BY YOU. THE EXCLUSION OF IMPLIED WARRANTIES IS NOT PERMITTED BY SOME STATES. THE ABOVE EXCLUSION MAY NOT APPLY TO YOU.

IN NO EVENT WILL BROTHER'S LICENSOR(S), AND THEIR DIRECTORS, OFFICERS, EMPLOYEES OR AGENTS (COLLECTIVELY BROTHER'S LICENSOR) BE LIABLE TO YOU FOR ANY CONSEQUENTIAL, INCIDENTAL OR INDIRECT DAMAGES (INCLUDING DAMAGES FOR LOSS OF BUSINESS PROFITS, BUSINESS INTERRUPTION LOSS OF BUSINESS INFORMATION, AND THE LIKE) ARISING OUT OF THE USE OR INABILITY TO USE THE SOFTWARE EVEN IF BROTHER'S LICENSOR HAS BEEN ADVISED OF THE POSSIBILITY OF SUCH DAMAGES. BECAUSE SOME STATES DO NOT ALLOW THE EXCLUSION OR LIMITATION OF LIABILITY FOR CONSEQUENTIAL OR INCIDENTAL DAMAGES, THE ABOVE LIMITATIONS MAY NOT APPLY TO YOU. Brother's Licensor's liability to you for actual damages from any cause whatsoever, and regardless of the form of the action (whether in contract, tort (including negligence), product liability or otherwise), will be limited to \$50.

COPYRIGHT © 1994 APPLE COMPUTER, INC. ALL RIGHTS RESERVED.

## Trademarks Notice

The brother logo is a registered trademark of Brother Industries, Ltd.

Apple, the Apple Logo, and Macintosh are trademarks, registered in the United States and other countries, and TrueType is a trademark of Apple Computer, Inc.

Centronics is a trademark of Genicom Corporation.

Epson is a registered trademark and FX-80 FX-850 are trademarks of Seiko Epson Corporation.

Hewlett Packard is registered trademarks and HP LaserJet II, IIP, and IID are trademarks of Hewlett-Packard Company.

IBM, IBM PC, and Proprinter are registered trademarks of International Business Machines Corporation.

Microsoft and MS-DOS are registered trademarks of Microsoft Corporation. Windows is a registered trademark of Microsoft Corporation in the U.S. and other countries.

All other brand and product names mentioned in this User's Guide are registered trademarks of their respective companies.

## Compilation and Publication Notice

Under the supervision of Brother Industries Ltd., this manual has been compiled and published, covering the latest product's descriptions and specifications.

The contents of this manual and the specifications of this product are subject to change without notice.

Brother reserves the right to make changes without notice in the specifications and materials contained herein and shall not be responsible for any damages (including consequential) caused by reliance on the materials presented, including but not limited to typographical and other errors relating to the publication.

©1994 Brother Industries Ltd.

**brother**<sup>®</sup>

Brother International Corporation  
200 Cottontail Lane,  
Somerset, NJ 08875-6714, U.S.A.

Brother International Corporation (Canada) Ltd.  
1 rue Hôtel de Ville,  
Dollard-des-Ormeaux, QC, CANADA H9B 3H6

\* Manufactured by Brother Industries Ltd. whose quality system is registered by BSI and JQA.

BSI Certificate of registration No. FM27391  
JQA Certificate of registration No. JQA-0340

## STATION ID SETTING

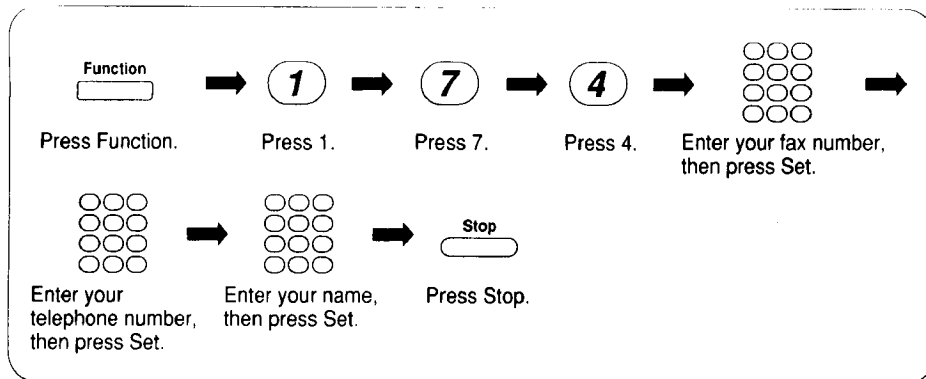

## TELEPHONE FUNCTION SETTING

### Storing One-Touch Dial Number

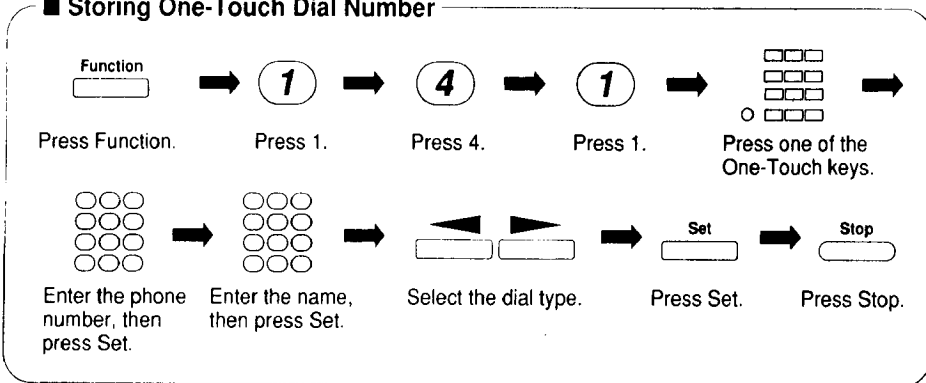

### Storing Speed - Dial Number

