

KitchenAid®

MICROWAVE OVEN

Use & Care Guide

For questions about features, operation/performance, parts, accessories or service, call: **1-800-422-1230**,
or visit our website at... www.kitchenaid.com

Table of Contents 2



Model KCMS1555
W10205301A



TABLE OF CONTENTS

MICROWAVE OVEN SAFETY	3
INSTALLATION INSTRUCTIONS	5
Unpacking	5
Location Requirements	5
Electrical Requirements	5
PARTS AND FEATURES	6
Turntable	6
MICROWAVE OVEN CONTROL	6
Display	6
Start	7
Add A Minute	7
Off	7
Clock	7
Tones	7
Timer	7
Control Lock	7
Options	7
MICROWAVE OVEN USE	8
Food Characteristics	8
Cooking Guidelines	8
Cookware and Dinnerware	8
Aluminum Foil and Metal	9
Microwave Cooking Power	9
Manual Cooking	9
Cooking in Stages	10
Custom Cooking	10
Custom Defrosting	10
Sensor Cooking	11
Sensor Cook	11
Sensor Popcorn	12
Sensor Reheat	12
Keep Warm	12
MICROWAVE OVEN CARE	13
General Cleaning	13
TROUBLESHOOTING	14
ASSISTANCE OR SERVICE	15
Replacement Parts	15
Built-In Kits	15
WARRANTY	16



MICROWAVE OVEN SAFETY

Your safety and the safety of others are very important.

We have provided many important safety messages in this manual and on your appliance. Always read and obey all safety messages.



This is the safety alert symbol.

This symbol alerts you to potential hazards that can kill or hurt you and others.

All safety messages will follow the safety alert symbol and either the word “DANGER” or “WARNING.”

These words mean:

⚠ DANGER

You can be killed or seriously injured if you don't immediately follow instructions.

⚠ WARNING

You can be killed or seriously injured if you don't follow instructions.

All safety messages will tell you what the potential hazard is, tell you how to reduce the chance of injury, and tell you what can happen if the instructions are not followed.

IMPORTANT SAFETY INSTRUCTIONS

When using electrical appliances basic safety precautions should be followed, including the following:

WARNING: To reduce the risk of burns, electric shock, fire, injury to persons, or exposure to excessive microwave energy:

- Read all instructions before using the microwave oven.
- Read and follow the specific “PRECAUTIONS TO AVOID POSSIBLE EXPOSURE TO EXCESSIVE MICROWAVE ENERGY” found in this section.
- The microwave oven must be grounded. Connect only to properly grounded outlet. See “GROUNDING INSTRUCTIONS” found in this section and in the provided Installation Instructions.
- Install or locate the microwave oven only in accordance with the provided Installation Instructions.
- Some products such as whole eggs in the shell and sealed containers – for example, closed glass jars – are able to explode and should not be heated in the microwave oven.
- Use the microwave oven only for its intended use as described in this manual. Do not use corrosive chemicals or vapors in the microwave oven. This type of oven is specifically designed to heat, cook, or dry food. It is not designed for industrial or laboratory use.
- As with any appliance, close supervision is necessary when used by children.
- Do not operate the microwave oven if it has a damaged cord or plug, if it is not working properly, or if it has been damaged or dropped.
- The microwave oven should be serviced only by qualified service personnel. Call an authorized service company for examination, repair, or adjustment.
- See door surface cleaning instructions in the “Microwave Oven Care” section.
- To reduce the risk of fire in the oven cavity:
 - Do not overcook food. Carefully attend the microwave oven when paper, plastic, or other combustible materials are placed inside the oven to facilitate cooking.
 - Remove wire twist-ties from paper or plastic bags before placing bags in oven.
 - If materials inside the oven ignite, keep oven door closed, turn oven off, and disconnect the power cord, or shut off power at the fuse or circuit breaker panel.
 - Do not use the cavity for storage purposes. Do not leave paper products, cooking utensils, or food in the cavity when not in use.
- Liquids, such as water, coffee, or tea are able to be overheated beyond the boiling point without appearing to be boiling. Visible bubbling or boiling when the container is removed from the microwave oven is not always present. **THIS COULD RESULT IN VERY HOT LIQUIDS SUDDENLY BOILING OVER WHEN THE CONTAINER IS DISTURBED OR A SPOON OR OTHER UTENSIL IS INSERTED INTO THE LIQUID.**
 - To reduce the risk of injury to persons:
 - Do not overheat the liquid.
 - Stir the liquid both before and halfway through heating it.
 - Do not use straight-sided containers with narrow necks.
 - After heating, allow the container to stand in the microwave oven for a short time before removing the container.
 - Use extreme care when inserting a spoon or other utensil into the container.
 - Oversized foods or oversized metal utensils should not be inserted in the microwave oven as they may create a fire or risk of electric shock.
 - Do not clean with metal scouring pads. Pieces can burn off the pad and touch electrical parts involving a risk of electric shock.

SAVE THESE INSTRUCTIONS

IMPORTANT SAFETY INSTRUCTIONS

- Do not operate any heating or cooking appliance beneath the microwave oven.
- Do not mount microwave oven over or near any portion of a heating or cooking appliance.
- Do not use paper products when appliance is operated in the "PAN BROWN" mode (on models with this feature).
- Do not store any materials, other than manufacturer's recommended accessories, in this microwave oven when not in use.
- Do not store anything directly on top of the microwave oven when the microwave oven is in operation.
- Do not cover or block any openings on the microwave oven.
- Do not store this microwave oven outdoors. Do not use the microwave oven near water - for example, near a kitchen sink, in a wet basement, or near a swimming pool, or similar locations.
- Do not immerse cord or plug in water.
- Keep cord away from heated surfaces.
- Do not let cord hang over edge of table or counter.
- Do not mount over a sink.
- Do not cover racks or any other part of the microwave oven with metal foil. This will cause overheating of the microwave oven.

SAVE THESE INSTRUCTIONS

PRECAUTIONS TO AVOID POSSIBLE EXPOSURE TO EXCESSIVE MICROWAVE ENERGY

- (a) Do not attempt to operate this oven with the door open since open-door operation can result in harmful exposure to microwave energy. It is important not to defeat or tamper with the safety interlocks.
- (b) Do not place any object between the oven front face and the door or allow soil or cleaner residue to accumulate on sealing surfaces.
- (c) Do not operate the oven if it is damaged. It is particularly important that the oven door close properly and that there is no damage to the:
 - (1) Door (bent),
 - (2) Hinges and latches (broken or loosened),
 - (3) Door seals and sealing surfaces.
- (d) The oven should not be adjusted or repaired by anyone except properly qualified service personnel.

This device complies with Part 18 of the FCC Rules.

INSTALLATION INSTRUCTIONS

Unpacking

1. Empty the microwave oven of any packing materials.
2. Clean the inside with a soft, damp cloth.
3. Check for damage, such as:
 - a door that is not lined up correctly
 - damage around the door, or
 - dents on the interior or exterior of the microwave oven.

If there is any damage, do not operate the microwave oven until a designated service technician has checked it and made any needed repairs.

Location Requirements

⚠ WARNING

Excessive Weight Hazard

Use two or more people to move and install microwave oven.

Failure to do so can result in back or other injury.

IMPORTANT: The control side of the microwave oven is the heavy side. Handle the microwave oven gently. The weight of the microwave oven is over 35 lbs (15.9 kg).

- Place the microwave oven on a cart, counter, table or shelf that is strong enough to hold the microwave oven and the food and utensils you place inside it.
- The microwave oven should be at a temperature above 50°F (10°C) for proper operation.

NOTE: Some models can be built into a wall or cabinet by using one of the trim kits listed in the "Assistance or Service" section.

- Do not block the exhaust vents or air intake openings. Allow a few inches of space at the back and side of the microwave oven where the exhaust vents are located. Blocking the exhaust vents could cause damage to the microwave oven, as well as poor cooking results.
- Make sure the microwave oven legs are in place to ensure proper airflow. If vents are blocked, a sensitive thermal device may automatically turn the microwave oven off. The microwave oven should work properly once it has cooled.

Electrical Requirements

⚠ WARNING



Electrical Shock Hazard

Plug into a grounded 3 prong outlet.

Do not remove ground prong.

Do not use an adapter.

Do not use an extension cord.

Failure to follow these instructions can result in death, fire, or electrical shock.

Observe all governing codes and ordinances.

Required:

- A 120 Volt, 60 Hz, AC only, 15- or 20-amp electrical supply with a fuse or circuit breaker.

Recommended:

- A time-delay fuse or time-delay circuit breaker.
- A separate circuit serving only this microwave oven.

GROUNDING INSTRUCTIONS

■ For all cord connected appliances:

The microwave oven must be grounded. In the event of an electrical short circuit, grounding reduces the risk of electric shock by providing an escape wire for the electric current. The microwave oven is equipped with a cord having a grounding wire with a grounding plug. The plug must be plugged into an outlet that is properly installed and grounded.

WARNING: Improper use of the grounding plug can result in a risk of electric shock. Consult a qualified electrician or serviceman if the grounding instructions are not completely understood, or if doubt exists as to whether the microwave oven is properly grounded.

Do not use an extension cord. If the power supply cord is too short, have a qualified electrician or serviceman install an outlet near the microwave oven.

SAVE THESE INSTRUCTIONS

PARTS AND FEATURES

This manual may cover several different models. The model you have purchased may have some or all of the features shown here. The appearance of your particular model may differ slightly from the illustrations in this manual.

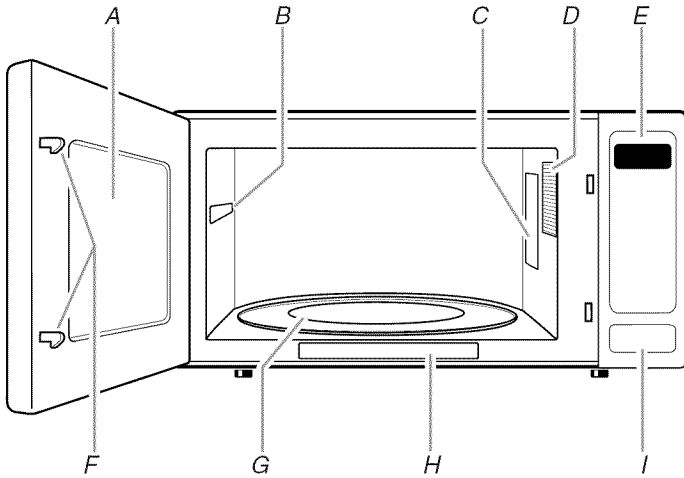

- A. Metal shielded window
- B. Model and serial number plate
- C. Microwave inlet cover
- D. Microwave oven light
- E. Control panel
- F. Door lock system
- G. Glass turntable
- H. Cooking guide label
- I. Door open push button

Turntable

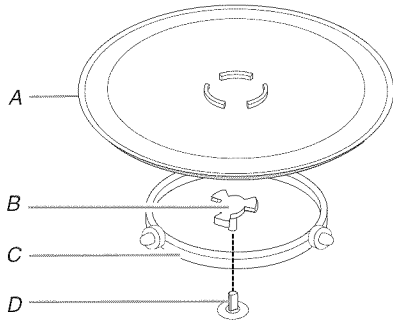

- A. Turntable
- B. Hub
- C. Support
- D. Shaft

The turntable can rotate in either direction to help cook food more evenly. For best cooking results, do not operate the microwave oven without having the turntable in place. See "Assistance or Service" to reorder any of the parts.

To Install:

1. Place the support on the microwave oven cavity bottom.
2. Place the turntable on the support.

Fit the raised, curved lines in the center of the turntable bottom between the three spokes of the hub. The rollers on the support should fit inside the turntable bottom ridge.

MICROWAVE OVEN CONTROL

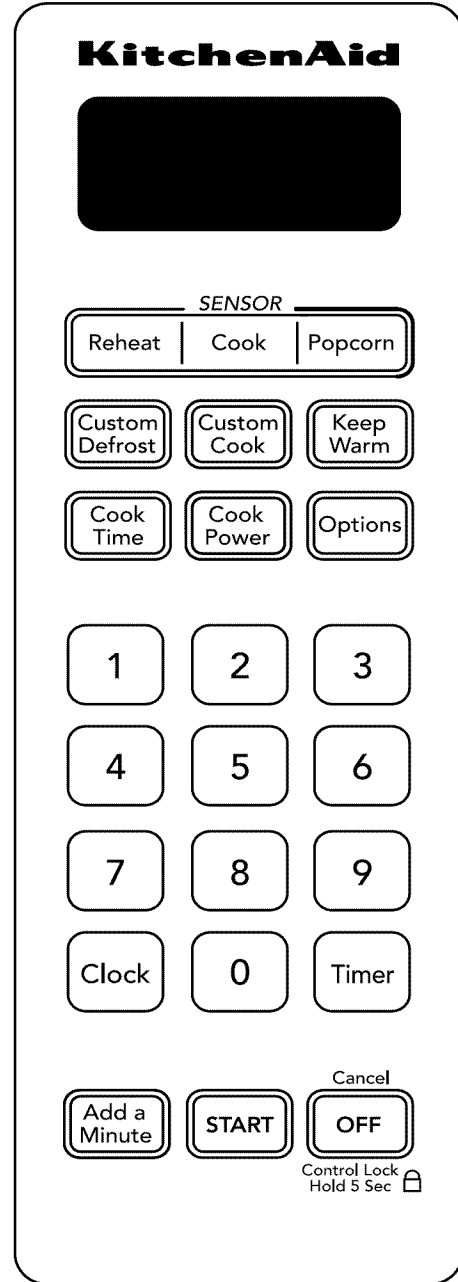

Display

When power is first supplied to the microwave oven, ":" will appear in the display. If the ":" appears in the display at any other time, a power failure has occurred. Reset the clock if needed.

When the microwave oven is in use, the display shows cook time remaining. When the microwave oven is not in use, the display shows the time of day (if the clock is set) or Timer countdown.

The clock may be turned on or off, the scroll speed may be adjusted and the weight measure may be changed using Options. See “Options” section.

Start

The START pad begins any function. If non-sensor cooking is interrupted, touching START will resume the preset cycle. Touching START will not resume an interrupted sensor cycle.

Add A Minute

Cook time may be added to a manual cook cycle by touching the ADD A MINUTE pad. Touching ADD A MINUTE during the cycle will add 1 minute of cook time at the current cook power. Each additional touch adds 1 minute of cook time.

The ADD A MINUTE pad will also start the microwave oven at 100% power for 1 minute after the door is closed or OFF is touched. Additional time may be added by touching ADD A MINUTE.

Off

The OFF pad clears any incorrect command, and cancels functions. It will not erase the time of day. OFF is also used to lock and unlock the control panel. See “Control Lock” section.

The microwave oven will also turn off when the door is opened. Close the door and touch START to resume the non-sensor cycle.

Clock

This is a standard 12-hour clock (12:00-11:59), with “P” as P.M. indicator (no indicator for A.M.).

To Set Clock:

The microwave oven and Timer must be off.

1. Touch CLOCK.
2. Touch number pads to correct time of day.
3. Touch CLOCK.

The clock may be hidden using Options. See “Options” section.

Tones

Tones are audible signals that may be turned off using Options. See “Options” section. These tones indicate the following:

One tone

- Valid entry

Two tones

- End of stage in multistage cooking
- Invalid entry (short tones)
- Hidden feature entered or exited

Four tones

- End of cycle

Five tones

- During defrost cycle, as reminder to check, turn, rearrange, or separate food

Seven tones

- End of Timer countdown

Timer

The Timer can be set in minutes and seconds, up to 99 minutes, 99 seconds, and counts down the set time.

NOTE: The Timer does not start or stop the microwave oven.

Cook functions may be used while the Timer is counting down. When the cook function is active in the display, touch and hold TIMER to see the Timer countdown.

To Set:

1. Touch TIMER.
2. Touch number pads to enter desired time.
3. Touch START.

When the set time ends, “END” will scroll across the display and the end-of-Timer tones will sound.

4. Touch OFF during the Timer countdown to cancel the Timer.

The time can be reset during the countdown by repeating the above steps.

The Timer cannot be canceled during a cook function without first canceling the cook function.

Control Lock

The Control Lock shuts down the control panel pads to avoid unintended use of the microwave oven. If any pad is touched while the Control Lock is active, “LOCKED” will appear in the display.

To Lock/Unlock Control: Touch and hold OFF for approximately 4 seconds until 2 tones sound and “LOCKED” appears in the display. Repeat to unlock the control. Two tones will sound, and the display will return to the time of day.

Options

Settings can be selected, and displays can be changed by using Options.

To Change Options: Touch OPTIONS repeatedly to select the option, then follow instructions on the display to select the setting.

OPTION	SETTING
Sound (tones)	On or Off
Clock	On or Off (hidden)
Scroll speed	Slow, Medium or Fast
Weight	lbs or kg
Language	English or French

MICROWAVE OVEN USE

A magnetron in the microwave oven produces microwaves which reflect off the metal floor, walls and ceiling and pass through the turntable and appropriate cookware to the food. Microwaves are attracted to and absorbed by fat, sugar and water molecules in the food, causing them to move, producing friction and heat which cooks the food.

- To avoid damage to the microwave oven, do not lean on or allow children to swing on the microwave oven door.
- To avoid damage to the microwave oven, do not operate when it is empty.
- Baby bottles and baby food jars should not be heated in microwave oven.
- Clothes, flowers, fruit, herbs, wood, gourds, paper, including brown paper bags and newspaper, should not be dried in microwave oven.
- Paraffin wax will not melt in the microwave oven because it does not absorb microwaves.
- Use oven mitts or pot holders when removing containers from microwave oven.
- Do not overcook potatoes. At the end of the recommended cook time, potatoes should be slightly firm. Let potatoes stand for 5 minutes. They will finish cooking while standing.
- Do not cook or reheat whole eggs inside the shell. Steam buildup in whole eggs may cause them to burst, requiring significant cleanup of microwave oven cavity. Cover poached eggs and allow a standing time.

Food Characteristics

When microwave cooking, the amount, size and shape, starting temperature, composition and density of the food affect cooking results.

Amount of Food

The more food heated at once, the longer the cook time needed. Check for doneness and add small increments of time if necessary.

Size and Shape

Smaller pieces of food will cook more quickly than larger pieces, and uniformly shaped foods cook more evenly than irregularly shaped food.

Starting Temperature

Room temperature foods will heat faster than refrigerated foods, and refrigerated foods will heat faster than frozen foods.

Composition and Density

Foods high in fat and sugar will reach a higher temperature, and will heat faster than other foods. Heavy, dense foods, such as meat and potatoes, require a longer cook time than the same size of a light, porous food, such as cake.

Cooking Guidelines

Covering

Covering food helps retain moisture, shorten cook time and reduce spattering. Use the lid supplied with cookware. If a lid is not available, wax paper, paper towels or plastic wrap approved for microwave ovens may be used. Plastic wrap should be turned back at one corner to provide an opening to vent steam. Condensation on the door and cavity surfaces is normal during heavy cooking.

Stirring and Turning

Stirring and turning redistribute heat evenly to avoid overcooking the outer edges of food. Stir from outside to center. If possible, turn food over from bottom to top.

Arranging

If heating irregularly shaped or different sized foods, arrange the thinner parts and smaller sized items toward the center. If cooking several items of the same size and shape, place them in a ring pattern, leaving the center of the ring empty.

Piercing

Before heating, use a fork or small knife to pierce or prick foods that have a skin or membrane, such as potatoes, egg yolks, chicken livers, hot dogs, and sausage. Prick in several places to allow steam to vent.

Shielding

Use small, flat pieces of aluminum foil to shield the thin pieces of irregularly shaped foods, bones and foods such as chicken wings, leg tips and fish tail. See "Aluminum Foil and Metal" first.

Standing Time

Food will continue to cook by the natural conduction of heat even after the microwave cooking cycle ends. The length of standing time depends on the volume and density of the food.

Cookware and Dinnerware

Cookware and dinnerware must fit on the turntable. Always use oven mitts or pot holders when handling because any dish may become hot from heat transferred from the food. Do not use cookware and dinnerware with gold or silver trim. Use the following chart as a guide, then test before using.

MATERIAL	RECOMMENDATIONS
Aluminum Foil, Metal	See "Aluminum Foil and Metal" section.
Browning Dish	Bottom must be at least 3/16" (5 mm) above the turntable. Follow manufacturer's recommendations.
Ceramic Glass, Glass	Acceptable for use.
China, Earthenware	Follow manufacturer's recommendations.

MATERIAL	RECOMMENDATIONS
Melamine	Follow manufacturer's recommendations.
Paper: Towels, Dinnerware, Napkins	Use nonrecycled and those approved by the manufacturer for microwave oven use.
Plastic: Wraps, Bags, Covers, Dinnerware, Containers	Use those approved by the manufacturer for microwave oven use.
Pottery and Clay	Follow manufacturer's recommendations.
Silicone Bakeware	Follow manufacturer's recommendations.
Straw, Wicker, Wooden Containers	Do not use in microwave oven.
Wax Paper	Acceptable for use.

To Test Cookware or Dinnerware for Microwave Use:

- Place cookware or dinnerware in microwave oven with 1 cup (250 mL) of water beside it.
 - Cook at 100% cooking power for 1 minute.
- Do not use cookware or dinnerware if it becomes hot and the water stays cool.

Aluminum Foil and Metal

Always use oven mitts or pot holders when removing dishes from the microwave oven.

Aluminum foil and some metal can be used in the microwave oven. If not used properly, arcing (a blue flash of light) can occur and cause damage to the microwave oven.

OK for Use

Racks and bakeware supplied with the microwave oven (on some models), aluminum foil for shielding, and approved meat thermometers may be used with the following guidelines:

- To avoid damage to the microwave oven, do not allow aluminum foil or metal to touch the inside cavity walls, ceiling or floor.
- Always use the turntable.
- To avoid damage to the microwave oven, do not allow contact with another metal object during microwave cooking.

Do Not Use

Metal cookware and bakeware, gold, silver, pewter, non-approved meat thermometers, skewers, twist ties, foil liners such as sandwich wrappers, staples and objects with gold or silver trim or a metallic glaze should not be used in the microwave oven.

Microwave Cooking Power

Many recipes for microwave cooking specify which cooking power to use by percent or name. For example, 70%=Medium-High.

Use the following chart as a general guide for the suggested cooking power of specific foods.

PERCENT/NAME	USE
100%, High (default setting)	Quick heating convenience foods and foods with high water content, such as soups, beverages and most vegetables.
90%	Cooking small, tender pieces of meat, ground meat, poultry pieces and fish fillets. Heating cream soups.
80%	Heating rice, pasta or stirrable casseroles. Cooking and heating foods that need a cook power lower than high. For example, whole fish and meat loaf.
70%, Medium-High	Reheating a single serving of food.
60%	Cooking sensitive foods such as cheese and egg dishes, pudding and custards. Cooking non-stirrable casseroles, such as lasagna.
50%, Medium	Cooking ham, whole poultry and pot roasts. Simmering stews.
40%	Melting chocolate. Heating bread, rolls and pastries.
30%, Medium-Low, Defrost	Defrosting bread, fish, meats, poultry and precooked foods.
20%	Softening butter, cheese, and ice cream.
10%, Low	Taking chill out of fruit.

Manual Cooking

To Use:

- Place food on the turntable, and close the door.
 - Touch COOK TIME.
"ENTER COOKING TIME" will scroll across display. Enter the length of time to cook.
If cooking with 100% power, skip Step 3.
 - Touch COOK POWER, then set the desired cooking power. See "Microwave Cooking Power."
 - Touch START.
When the cycle ends, "END" will appear in the display, and the end-of-cycle tones will sound.
 - Touch OFF or open the door to clear the display.
- Cook time may be added in 1-minute increments during the cycle by touching ADD A MINUTE.

Cooking in Stages

The microwave oven can be set to cook at different cooking powers for various lengths of time, up to 2 stages.

To Cook in Stages:

1. Place food on the turntable, and close the door.
2. Touch COOK TIME.
“ENTER COOKING TIME” will scroll across display. Enter the length of time to cook during the first stage.
3. Touch COOK POWER, then enter the desired cooking power for the 1st stage. See “Microwave Cooking Power.”
4. Repeat steps 2 and 3 for second stage.
5. Touch START.
Two tones will sound between stages.

When the cycle ends, “END” will appear in the display, and the end-of-cycle tones will sound.

6. Touch OFF or open the door to clear the display.

Cook time may be added in 1 minute increments during the cycling stage by touching ADD A MINUTE.

Custom Cooking

Times and cooking power have been preset for certain microwavable foods. Use the following chart as a guide.

FOOD	QUANTITY/INSTRUCTIONS
Bacon*	2-6 slices, average thickness/ Follow directions on package.
Frozen Roll/Muffin (prebaked)	1-6 pieces, 2 oz (57 g) each**/ Place on paper towel.
Fresh Roll/Muffin (prebaked)	1-6 pieces, 2 oz (57 g) each**/ Place on paper towel.
Beverage	1 or 2 cups, 8 oz (250 mL) each/ Do not cover. The diameter of the cup's opening will affect how the liquid heats. Beverages in cups with smaller openings may heat faster.
Chicken Pieces	0.5-2.0 lbs (227-907 g)/ Place in microwave-safe container and add 2-4 tbs (30-60 mL) liquid. Cover with plastic wrap. Let stand 2-3 minutes after cooking.
Hot Cereal	1-6 servings/ Follow directions on package. Use microwave-safe bowls with high sides.

*Differences in the amount of fat, meat, thickness, and curing process affect results. Average is 16 slices per pound.

**For smaller rolls, 2 rolls may be counted as 1 piece.

To Use Custom Cook:

1. Place food on the turntable, and close the door.
2. Touch CUSTOM COOK repeatedly to scroll through foods.
3. Enter quantity.
4. Touch START or wait for the microwave oven to start automatically after a brief delay.
The display will count down the cook time.

When the cycle ends, “END” will appear in the display, and the end-of-cycle tones will sound.
5. Touch OFF or open the door to clear the display.

Custom Defrosting

The Custom Defrost feature's preset programs can be used, or the microwave oven can be manually set to defrost.

- Unwrap foods and remove lids (for example, from fruit juice containers) before defrosting.
- Shallow packages will defrost more quickly than thick blocks.
- Separate food pieces as soon as possible during or at the end of the cycle for more even defrosting.
- Use small pieces of aluminum foil to shield parts of food such as chicken wings, leg tips and fish tails. See “Aluminum Foil and Metal” first.

The Custom Defrost feature has preset times and cook powers for 3 categories: Meat, Poultry and Fish. Custom Defrost should not be used for food that has been left outside the freezer for more than 20 minutes, or for frozen ready-made food. Use the following chart as a guide.

MEAT

<i>Beef</i> : ground, steaks, roast, stew	The narrow or fatty areas of irregular shaped cuts should be shielded with foil before defrosting.
<i>Lamb</i> : stew and chops	
<i>Pork</i> : chops, ribs, roasts, sausage	Do not defrost less than 1/4 lb (113 g) or two 4 oz (113 g) patties. Place all meats in microwave-safe baking dish. Do not cover.

POULTRY

<i>Chicken</i> : whole and cut up	Place in microwave-safe baking dish, chicken breast side up. Do not cover.
<i>Cornish hens</i>	
<i>Turkey</i> : breast	

FISH

<i>Fillets, Steaks, Whole, Shellfish</i>	Place in microwave-safe baking dish. Do not cover.
--	--

To Use Custom Defrost:

1. Place food, uncovered, on the turntable and close the door.
2. Touch CUSTOM DEFROST.
The display will show the setting for defrosting Meat. Touch CUSTOM DEFROST a second time for the Poultry setting, and a third time for the Fish setting.
3. Enter the weight.
Weight can be set from 0.1 to 6.0 lbs (45 g to 2.7 kg).
4. Touch START.

The display will count down the defrost time.

During defrosting, 5 short tones will sound. These tones indicate it is time to check, turn, rearrange or separate food. Open door, turn food if necessary, close door and touch START to resume defrosting.

When the cycle ends, "END" will appear in the display, and the end-of-cycle tones will sound, followed by reminder tones.

5. Touch OFF or open the door to clear the display.

To Defrost Manually: Follow directions in "Manual Cooking" section, and use 30% cooking power. See "Microwave Cooking Power" chart.

Sensor Cooking

A sensor in the microwave oven detects humidity released from the food as it heats, and adjusts the cook time accordingly.

Many sensor cycles require the covering of foods. Microwave-safe containers or steamers with loose-fitting lids are recommended. The loose-fitting lid allows enough steam to escape to be detected by the sensor. When covering foods with plastic wrap, be sure to leave a large enough vent opening to allow the steam to escape.

NOTES:

- The microwave oven should be plugged in for at least 3 minutes.
- The microwave oven cavity and the exterior of the cooking container should be dry.
- The room temperature should not exceed 95°F (35°C).
- If the door is opened during a sensor cycle, sensing will stop and the program will be canceled.

Sensor Cook

The sensor in the microwave oven detects humidity released from the food and automatically sets a cooking time based on the selected food category.

Use the following chart as a guide.

FOOD	QUANTITY/INSTRUCTIONS
Frozen Pizza	6-7 oz (170-198 mL)/ Follow directions on package.
Baked Potato	1-4 medium, 10-13 oz (283-369 g) each/ Pierce each one several times with a fork. Place on turntable around edges, at least 1" (2.5 cm) apart. Let stand 5 minutes after cooking.

FOOD	QUANTITY/INSTRUCTIONS
Fresh Vegetables	1-4 cups (250 mL-1 L)/ Place in microwave-safe container and add 2-4 tbs (30-60 mL) water. Cover with plastic wrap and vent. Stir and let stand 2-3 minutes after cooking.
Frozen Vegetables	1-4 cups (250 mL-1 L)/ Remove from package. Place in microwave-safe container. Cover with plastic wrap and vent. Stir and let stand 2-3 minutes after cooking.
Frozen Entrée	10-20 oz (283-567 g)/ Remove from package. Loosen cover on three sides. If entrée is not in microwave-safe container, place on plate, cover with plastic wrap and vent.
Rice	0.5-2 cups (125-500 mL) dry rice (Use medium or long grain rice.)/ Follow measurements on package for ingredient amounts. Place rice and liquid in microwave-safe dish. Cover with loose-fitting lid. Let stand 5 minutes after cooking, or until liquid is absorbed. Stir.
Casserole	1-4 cups (250 mL-1 L)/ Place in microwave-safe container, cover with plastic wrap and vent. Stir and let stand 2-3 minutes after cooking.
Ground Meat	8-32 oz (227-907 g)/ Crumble meat into a microwave-safe container. Cover with plastic wrap and vent. Stir and let stand 2-3 minutes after cooking.
Fish/Seafood	4-16 oz (113-454 g)/ Place in microwave-safe dish and add 2-4 tbs (30-60 mL) liquid. Cover with plastic wrap and vent. Let stand 2-3 minutes after cooking.
Eggs	2-5 eggs/ Break eggs into a microwave-safe container with high sides. Add 1 tbs (15 mL) water per egg and beat. Cover with plastic wrap and vent. Stir and let stand 2-3 minutes after cooking.

NOTE: When covering foods, make sure the vent opening is large enough for moisture to escape. This will allow the sensor to accurately determine cooking time.

To Use Sensor Cook:

1. Place food on the turntable and close the door.
2. Touch COOK until the desired food type is displayed.
The microwave oven will start automatically after a brief delay.
When the cycle ends, "END" will appear in the display, and the end-of-cycle tones will sound.
3. Touch OFF or open the door to clear the display.

Sensor Popcorn

The sensor in the microwave oven determines the appropriate popping time of commercially packaged microwavable popcorn. This function is programmed to detect popping times for 3.5-oz (99 g), 3.0-oz (85 g) and 1.75-oz (50 g) bags.

NOTE: During Popcorn function, as with all microwave cooking functions, the microwave oven should be attended at all times. Listen for popping to slow to 1 pop every 1 or 2 seconds, then stop the cycle.

- To avoid damage to the microwave oven, do not use regular paper bags or glassware.
- Pop only 1 package of popcorn at a time.
- Follow manufacturer's instructions when using a microwave popcorn popper.
- For best cooking results, do not try to pop unpopped kernels.
- Use fresh bags of popcorn for optimal results.
- Cooking results may vary by brand and fat content. For bag sizes not listed in this section, follow directions on the package.

To Use Sensor Popcorn:

1. Place popcorn bag on the turntable and close the door.
2. Touch POPCORN once for Regular (3.0-3.5 oz [85-99 g]), or twice for Snack (1.75 oz [50 g]).

The microwave oven will start automatically after a brief delay.

When the cycle ends, "END" will appear in the display, and the end-of-cycle tones will sound.

3. Touch OFF or open the door to clear the display.

Sensor Reheat

The sensor in the microwave oven determines the reheating time based on the selection. Use the following chart as a guide.

FOOD	SERVING SIZE/INSTRUCTIONS
Dinner Plate (refrigerated)	8-16 oz (227-454 g) Place food on microwave-safe plate, cover with plastic wrap and vent.
Soup/Sauce	1-4 cups (250 mL-1 L) Place in microwave-safe container, cover with plastic wrap and vent. Stir and let stand 2-3 minutes after reheating.
Casserole (refrigerated)	1-2 cups (250-500 mL) Place in microwave-safe container, cover with plastic wrap and vent. Stir and let stand 2-3 minutes after reheating.

NOTE: When covering foods, make sure the vent opening is large enough for moisture to escape. This will allow the sensor to accurately determine reheating time.

To Use Sensor Reheat:

1. Place food on the turntable and close the door.
2. Touch REHEAT until the desired food type is displayed.
The microwave oven will start automatically after a brief delay.

When the cycle ends, "END" will appear in the display, and the end-of-cycle tones will sound.

3. Touch OFF or open the door to clear the display.

Keep Warm

⚠ WARNING

Food Poisoning Hazard

Do not let food sit in oven more than one hour before or after cooking.

Doing so can result in food poisoning or sickness.

Hot cooked food can be kept warm in the microwave oven. The Keep Warm function uses 10% cook power. Keep Warm can be used by itself, or it can be programmed to follow a cooking cycle.

- Cover plates of food.
- Cover foods that were covered while being cooked.
- For best results, do not cover baked goods such as pastries, pies, turnovers, etc.

To Use:

1. Place hot cooked food on the turntable and close the door.
2. Touch KEEP WARM.

"KEEP WARM" will scroll twice, and then "TOUCH START" will scroll.

3. Touch START.

"KEEP WARM" will appear in the display during the entire cycle.

When the cycle ends, "END" will appear in the display, and the end-of-cycle tones will sound.

4. Touch OFF or open the door to clear the display.

To Set at end of cycle: Touch KEEP WARM while setting a cooking cycle before touching START.

MICROWAVE OVEN CARE

General Cleaning

IMPORTANT: Before cleaning, make sure all controls are off and the microwave oven is cool. Always follow label instructions on cleaning products.

Soap, water and a soft cloth or sponge are suggested unless otherwise noted.

MICROWAVE OVEN CAVITY

To avoid damage to the microwave oven cavity, do not use soap-filled scouring pads, abrasive cleaners, steel-wool pads, gritty washcloths or some recycled paper towels.

To avoid damage to stainless steel models, rub in direction of grain.

The area where the microwave oven door and frame touch when closed should be kept clean.

Average soil

- Mild, nonabrasive soaps and detergents:
Rinse with clean water and dry with soft, lint-free cloth.

Heavy soil

- Mild, nonabrasive soaps and detergents:
Heat 1 cup (250 mL) of water for 2 to 5 minutes in microwave oven. Steam will soften soil. Rinse with clean water and dry with soft, lint-free cloth.

Odors

- Lemon juice or vinegar:
Heat 1 cup (250 mL) of water with 1 tbs (15 mL) of either lemon juice or vinegar for 2 to 5 minutes in microwave oven.

Microwave Inlet Cover

To avoid arcing and microwave oven damage, the microwave inlet cover (see “Parts and Features”) should be kept clean.

- Wipe with wet cloth.

MICROWAVE OVEN DOOR AND EXTERIOR

The area where the microwave oven door and frame touch when closed should be kept clean.

- Mild, nonabrasive soaps and detergents:
Rinse with clean water and dry with soft, lint-free cloth.
- Glass cleaner and paper towels or nonabrasive plastic scrubbing pad:
Apply glass cleaner to towel, not directly to surface.

Stainless Steel (on some models)

To avoid damage to the microwave oven door and exterior, do not use soap-filled scouring pads, abrasive cleaners, steel-wool pads, gritty washcloths or some paper towels. Rub in direction of grain.

- KitchenAid® Stainless Steel Cleaner and Polish (not included)
KitchenAid® Stainless Steel Wipes (not included):
See “Assistance or Service” section to order.
- Liquid detergent or all-purpose cleaner:
Rinse with clean water and dry with soft, lint-free cloth.
- Vinegar for hard water spots

TURNTABLE

Replace turntable immediately after cleaning. Do not operate the microwave oven without the turntable in place.

- Mild cleanser and scouring pad
- Dishwasher

TROUBLESHOOTING

Try the solutions suggested here first in order to avoid the cost of an unnecessary service call.

Nothing will operate

- **Has a household fuse blown, or has a circuit breaker tripped?**
Replace the fuse or reset the circuit breaker. If the problem continues, call an electrician.

Microwave oven will not operate

- **Is the magnetron working properly?**
Try to heat 1 cup (250 mL) of cold water for 2 minutes at 100% cooking power. If water does not heat, try the steps below. If microwave oven still does not operate, call for service. See “Assistance or Service” section.
- **Is the door completely closed?**
Firmly close door.
- **Is a packaging spacer (on some models) attached to the inside of the door?**
Remove packaging spacer, then firmly close door.
- **Is the electronic microwave oven control set correctly?**
See “Microwave Oven Control” section.
- **On some models, is the Control Lock set?**
See “Control Lock” section.

Microwave oven makes humming noise

- This is normal and occurs when the power supply switches the magnetron on and off.

Microwave oven door looks wavy

- This is normal and will not affect performance.

Turntable will not operate

- **Is the turntable properly in place?**
Make sure turntable is correct side up and is sitting securely on the turntable support. See “Turntable” section.
- **Is the turntable support operating properly?**
Remove turntable. Remove and clean turntable hub, support and rollers. Replace hub, support and turntable. Place 1 cup (250 mL) of water on the turntable, then restart microwave oven. If it still is not working, call for service. See “Assistance or Service” section. Do not operate the microwave oven without turntable and turntable support working properly.

Turntable alternates rotation directions

- This is normal and depends on motor rotation at beginning of cycle.

Display shows messages

- **Is the display showing “:”?**
The clock has not been set. See “Display” section to clear display. See “Clock” section to reset the clock.
- **Is the display showing a letter followed by a number?**
See “Display” section to clear. If it reappears, call for service. See “Assistance or Service” section.

Display shows time countdown, but the microwave oven is not operating

- **Is the Timer in use?**
See “Timer” section.

Tones are not sounding

- **Are tones turned off?**
See “Tones” section.

Cooking times seem too long

- **Is the cooking power set properly?**
See “Microwave Cooking Power” section.
- **Are large amounts of food being heated?**
Larger amounts of food need longer cooking times.
- **Is the incoming voltage less than that specified in “Microwave Oven Safety?”**
Have a qualified electrician check the electrical system in the home.

Interference with radio, TV, cordless phone, etc.

- **Is the microwave oven plugged into the same outlet?**
Try a different outlet for the electronic device.
- **Is the radio or TV receiver near the microwave oven?**
Move the receiver away from the microwave oven, or adjust the radio or TV antenna.
- **Are the microwave oven door and sealing surfaces clean?**
Make sure these areas are clean.
- **Is the cordless phone frequency 2.4 GHz?**
Some 2.4 GHz-based cordless phones and home wireless networks may experience static or noise while the microwave oven is on. Use a corded phone or a different frequency cordless phone, or avoid using these items during microwave oven operation.

ASSISTANCE OR SERVICE

Before calling for assistance or service, please check "Troubleshooting." It may save you the cost of a service call. If you still need help, follow the instructions below.

When calling, please know the purchase date and the complete model and serial number of your appliance. This information will help us to better respond to your request.

If you need replacement parts

If you need to order replacement parts, we recommend that you use only factory specified parts. These factory specified parts will fit right and work right because they are made with the same precision used to build every new KITCHENAID® appliance.

To locate factory specified parts in your area, call us or your nearest KitchenAid designated service center.

In the U.S.A.

Call the KitchenAid Customer eXperience Center toll free: **1-800-422-1230.**

Our consultants provide assistance with:

- Features and specifications on our full line of appliances.
- Installation information.
- Use and maintenance procedures.
- Accessory and repair parts sales.
- Specialized customer assistance (Spanish speaking, hearing impaired, limited vision, etc.).
- Referrals to local dealers, repair parts distributors and service companies. KitchenAid designated service technicians are trained to fulfill the product warranty and provide after-warranty service, anywhere in the United States.

To locate the KitchenAid designated service company in your area, you can also look in your telephone directory Yellow Pages.

For further assistance

If you need further assistance, you can write to KitchenAid with any questions or concerns at:

KitchenAid Brand Home Appliances
Customer eXperience Center
553 Benson Road
Benton Harbor, MI 49022-2692

Please include a daytime phone number in your correspondence.

Replacement Parts

Glass Turntable
Part Number W10143945

Turntable Support and Rollers
Part Number W10143946

Turntable Hub
Part Number W10143947

Cleaning Supplies

Heavy Duty Degreaser
Part Number 31552

All-Purpose Appliance Cleaner
Part Number 31682

KITCHENAID® Stainless Steel
Cleaner and Polish
Part Number 4396920

KITCHENAID® Stainless Steel
Wipes
Part Number 8212510

Built-In Kits

This countertop microwave oven can be built in by using one of the following trim kits*. These kits are available from the dealer or can be ordered by kit model number. See "Assistance or Service" section for the toll-free number.

KIT SIZE	KIT MODEL NUMBERS/ COLORS	FOR INSTALLATION OVER OVEN MODELS
24" (61 cm)	MK1154XVQ / White	KEBI141D
	MK1154XVB / Black	KEBS147D
	MK1154XVS / Stainless	
27" (69 cm)	MK1157XVQ / White	KEBI171D
	MK1157XVB / Black	KEBS177D
	MK1157XVS / Stainless	
30" (76 cm)	MK1150XVQ / White	KEBI101D
	MK1150XVB / Black	KEBS107D
	MK1150XVS / Stainless	

*Approved, electric single microwave ovens only

KITCHENAID® BUILT-IN OVEN & MICROWAVE WARRANTY

LIMITED WARRANTY

For one year from the date of purchase, when this major appliance is operated and maintained according to instructions attached to or furnished with the product, KitchenAid brand of Whirlpool Corporation or Whirlpool Canada LP (hereafter "KitchenAid") will pay for Factory Specified Parts and repair labor to correct defects in materials or workmanship. Service must be provided by a KitchenAid designated service company. This limited warranty is valid only in the United States or Canada and applies only when the major appliance is used in the country in which it was purchased. Outside the 50 United States and Canada, this limited warranty does not apply. Proof of original purchase date is required to obtain service under this limited warranty.

SECOND THROUGH FIFTH YEAR LIMITED WARRANTY ON CERTAIN COMPONENT PARTS

In the second through fifth years from the date of purchase, when this appliance is operated and maintained according to instructions attached to or furnished with the product, KitchenAid will pay for Factory Specified Parts for the following components if defective in materials or workmanship:

- Electric element
- Solid state touch control system parts

SECOND THROUGH TENTH YEAR LIMITED WARRANTY

On microwave ovens only, in the second through tenth years from date of purchase, when this major appliance is operated and maintained according to instructions attached to or furnished with the product, KitchenAid will pay for Factory Specified Parts for the stainless steel oven cavity/inner door if the part rusts through due to defects in materials or workmanship.

ITEMS EXCLUDED FROM WARRANTY

This limited warranty does not cover:

1. Service calls to correct the installation of your major appliance, to instruct you on how to use your major appliance, to replace or repair house fuses, or to correct house wiring or plumbing.
2. Service calls to repair or replace appliance light bulbs, air filters or water filters. Consumable parts are excluded from warranty coverage.
3. Repairs when your major appliance is used for other than normal, single-family household use or when it is used in a manner that is contrary to published user or operator instructions and/or installation instructions.
4. Damage resulting from accident, alteration, misuse, abuse, fire, flood, acts of God, improper installation, installation not in accordance with electrical or plumbing codes, or use of consumables or cleaning products not approved by KitchenAid.
5. Cosmetic damage, including scratches, dents, chips or other damage to the finish of your major appliance, unless such damage results from defects in materials or workmanship and is reported to KitchenAid within 30 days from the date of purchase.
6. Costs associated with the removal from your home of your major appliance for repairs. This major appliance is designed to be repaired in the home and only in-home service is covered by this warranty.
7. Repairs to parts or systems resulting from unauthorized modifications made to the appliance.
8. Expenses for travel and transportation for product service if your major appliance is located in a remote area where service by an authorized KitchenAid servicer is not available.
9. The removal and reinstallation of your major appliance if it is installed in an inaccessible location or is not installed in accordance with published installation instructions.
10. Major appliances with original model/serial numbers that have been removed, altered or cannot be easily determined. This warranty is void if the factory applied serial number has been altered or removed from your major appliance.

The cost of repair or replacement under these excluded circumstances shall be borne by the customer.

DISCLAIMER OF IMPLIED WARRANTIES; LIMITATION OF REMEDIES

CUSTOMER'S SOLE AND EXCLUSIVE REMEDY UNDER THIS LIMITED WARRANTY SHALL BE PRODUCT REPAIR AS PROVIDED HEREIN. IMPLIED WARRANTIES, INCLUDING WARRANTIES OF MERCHANTABILITY OR FITNESS FOR A PARTICULAR PURPOSE, ARE LIMITED TO ONE YEAR OR THE SHORTEST PERIOD ALLOWED BY LAW. KITCHENAID SHALL NOT BE LIABLE FOR INCIDENTAL OR CONSEQUENTIAL DAMAGES. SOME STATES AND PROVINCES DO NOT ALLOW THE EXCLUSION OR LIMITATION OF INCIDENTAL OR CONSEQUENTIAL DAMAGES, OR LIMITATIONS ON THE DURATION OF IMPLIED WARRANTIES OF MERCHANTABILITY OR FITNESS, SO THESE EXCLUSIONS OR LIMITATIONS MAY NOT APPLY TO YOU. THIS WARRANTY GIVES YOU SPECIFIC LEGAL RIGHTS, AND YOU MAY ALSO HAVE OTHER RIGHTS WHICH VARY FROM STATE TO STATE OR PROVINCE TO PROVINCE.

If outside the 50 United States and Canada, contact your authorized KitchenAid dealer to determine if another warranty applies.

If you need service, first see the "Troubleshooting" section of the Use & Care Guide. After checking "Troubleshooting," you may find additional help by checking the "Assistance or Service" section or by calling KitchenAid. In the U.S.A., call **1-800-422-1230**. In Canada, call **1-800-807-6777**.

9/07

Keep this book and your sales slip together for future reference. You must provide proof of purchase or installation date for in-warranty service.

Write down the following information about your major appliance to better help you obtain assistance or service if you ever need it. You will need to know your complete model number and serial number. You can find this information on the model and serial number label located on the product.

Dealer name _____

Address _____

Phone number _____

Model number _____

Serial number _____

Purchase date _____

W10205301A
SP PN W10205310A

© 2008. All rights reserved.

©Registered Trademark/TM Trademark of KitchenAid, U.S.A.

MFL42079202
6/08
Printed in China

