

DATE: 20250912

# ZMP-52 NFC Padlock

## Datasheet



Chengdu Hizima Technology Co., Ltd

## 1. Product overview



### 1.1. Introduction

The most significant feature of the ZMP-52 NFC padlock is that it requires neither a built-in battery nor an external power supply, making it completely maintenance-free for life. The power required for unlocking is harvested through contactless NFC inductive coupling from an NFC-enabled smartphone or NFC FOB during communication.

The ZMP-52 NFC Padlock features a stainless steel lock body and an alloy steel shackle, offering an overall waterproof rating of IP68. It is especially suitable for environments with high security requirements. The lock has no built-in battery. It is powered by an NFC reader (e.g., NFC-enabled smartphone), requiring no batteries or external power. With keyless operation, it is ideal for applications where external power is unavailable or battery replacement is impractical.

The ZMP-52 NFC Padlock is integrated with a microprocessor and works in conjunction with the Hizima management APP to enable functions such as unlocking, power management, and access log tracking. With internet connectivity, the lock core supports centralized authorization and can operate in both online and offline modes, enabling distributed centralized management of large-scale lock networks. It is widely applicable in industries such as telecommunications, petrochemicals, transportation, and power utilities.

## 1.2. Key Features

- Bi-directional encryption and authentication security chip, preventing technical unlock.
- Keyless operations via APP.
- Full-metal housing design provides superior resistance against physical attacks.
- The dual-side load-bearing locking structure enhances resistance against pulling force, ensuring greater security.
- Pop-up shackle design;
- Dual unlocking modes: Bluetooth and NFC;
- Powered by NFC reader energy — battery-free operation for NFC unlocking;
- USB Type-C emergency power supply for Bluetooth unlocking.

## 1.3. Workflow

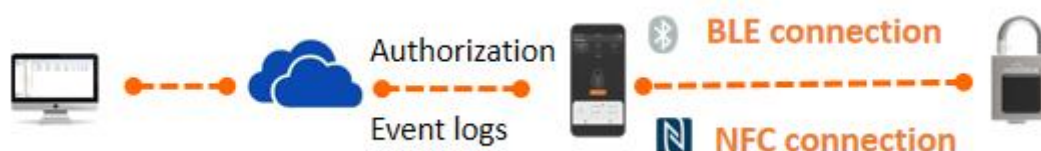

## 2. Specification

Model	ZMP-52
Communication	<ul style="list-style-type: none"> <li>◆ NFC(ISO/IEC 14443-2 and 14443-3、 13.56MHz)</li> <li>◆ <b>Bluetooth</b> (BLE 5.0, frequency range: 2402MHz–2480MHz, transmit power &lt;10mW)</li> </ul>
Unlock mode	APP NFC/APP BLE
Logs storage	>1000
Power Supply	NFC/USB Type-C
Lock body materials	SUS304
Shackle diameter	11mm
Shackle materials	Harden alloy steel(HRC 45-50) with chrome plated surface

Shackle length	62mm(Locked status)
Shackle structure	Pull-apart, dual-side load-bearing locking structure Tensile Strength: 35kN / 65kN
Working environment	Temperature:-35—70 °C (Not freezing below 0 °C .) Humidity:5—90%
IP rating	IP68
Corrosion Resistance	AASS (Acetic Acid Salt Spray) test >96h
Net weight	810g
Lanyard	1pc
External power supply	USB TYPE-C DC5V

### 3. Dimensions

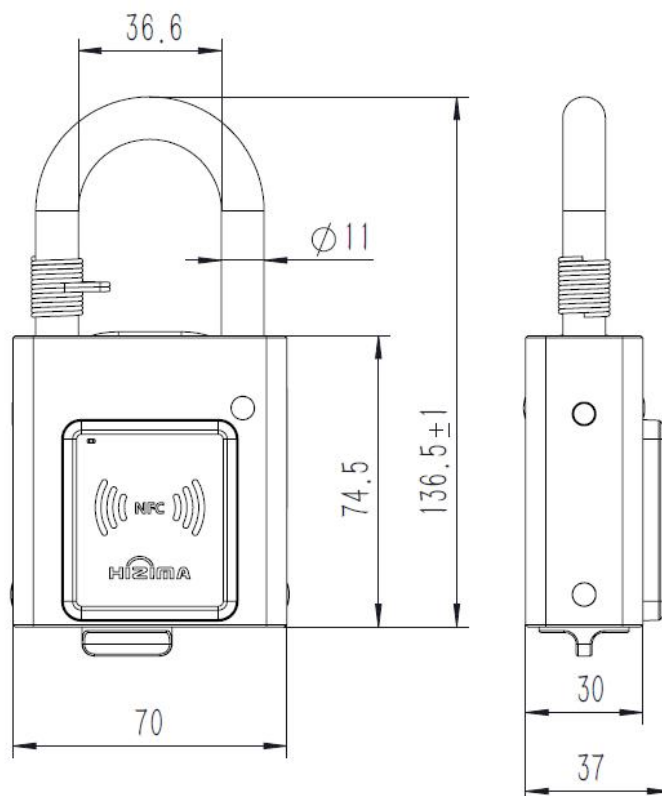

Unit: mm

## 4. Operation

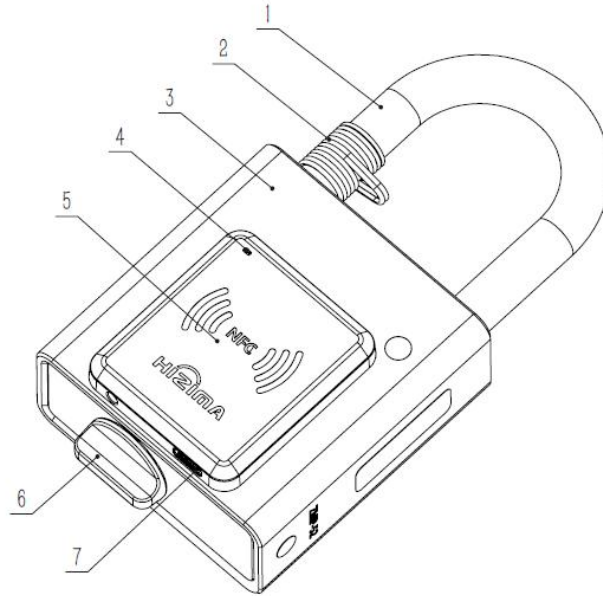

1. Shackle 2. Lanyard hook 3. Lock body 4. Indicator 5. NFC charging area  
6. Knob 7. USB Type-C power port

### 4.1. Power-On

#### 4.1.1. Power-on via NFC

- Open the ZMACS APP.
- Align the NFC transmission antenna area of an NFC-enabled mobile phone closely with the center of the lock's NFC charging area.
- Once charging is complete, the APP will provide a notification.

#### **Indicator light behavior:**

- When the device reaches operating voltage and the NFC field disappears → indicator light remains steadily on until power is depleted.
- When the NFC field is present or the power is insufficient → indicator light remains off.

**Communication mode:** When powered on via NFC charging, the communication method between the APP and the lock is NFC.



**Notes:** Charging time may vary significantly depending on the NFC mobile phone model. In extreme cases, some phones may not be able to charge the lock to operating voltage. If the phone has a protective case and the lock cannot be powered on, remove the case and try again. The better the alignment between the phone's NFC antenna and the lock's NFC charging area, and the shorter the distance between them, the shorter the charging time.

#### 4.1.2. Power-on via USB

- Connect an external DC 5V power supply to the USB Type-C port at the bottom of the NFC charging area.
- The lock will power on immediately and wait to enter the lock/unlock process.

#### **Indicator light behavior:**

- Without Bluetooth connection → indicator light remains steadily on.
- With Bluetooth connection → after successful pairing with the APP, the red indicator flashes once every 2 seconds.

**Communication mode:** When powered on via NFC charging, the communication method between the APP and the lock is **NFC**.

#### 4.1.3. Communication Mode Switching

\*\* Switching between NFC and BLE communication modes can only be performed when the indicator light is off. If the indicator light is on, the lock will remain in the previous communication mode.

## 4.2. Locking and Unlocking

### 4.2.1. Unlocking

- Operate the unlocking function in the APP.
- The APP interface will display the lock status (battery level, lock/unlock status, etc.). For more details, refer to the APP user guide.

- 
- When the APP indicates unlocking is successful, turn the knob **clockwise about 90°** → the shackle will automatically pop open.

**Log storage:** Each unlocking event is recorded in the lock. The lock can store at least 1,000 logs.

#### 4.2.2. Locking

- Keep the knob in a free state.
- Press down the shackle into the closed position.
- Send the locking command via the APP (the lock must be powered on and have sufficient battery).

For detailed instructions, please refer to the APP user guide.

#### 4.3. Use of the Lanyard

After unlocking, to prevent the lock from being misplaced or dropped, use the lanyard to secure the lanyard hook of the lock to another object, such as a fence or gate latch.

### 5. Dos and Don' ts

1. Please DO NOT exceed the limits specified in this document when using it.
2. During use, DO handle with care and avoid dropping to prevent damage to the device or injury.
3. This product is not explosion-proof and please DO NOT use it in flammable or explosive environments.
4. DO NOT strike the lock body with force and avoid wiping the surface of the lock body with corrosive substances.
5. This product is designed to be waterproof. Unauthorized personnel DO NOT disassemble the product to avoid affecting its waterproof performance. If the drain hole are blocked by foreign objects, they should be cleaned to ensure proper drainage

6. If the lock is deployed outdoors for long periods without using, the shackle and lock body may be covered with mud or large amounts of dust. DO clean it thoroughly before unlocking. After unlocking, pull out the shackle and clean it again, including the shackle hole.



[WWW.HIZIMA.COM](http://WWW.HIZIMA.COM)

D2 Mold Industrial Park, No.199 Xiqu Avenue, Hi-Tech zone, Chengdu, Sichuan,  
China

This device complies with Part 15 of the FCC Rules. Operation is subject to the following two conditions: (1) this device may not cause harmful interference, and (2) this device must accept any interference received, including interference that may cause undesired operation.

Changes or modifications to this unit not expressly approved by the party responsible for compliance could void the user's authority to operate the equipment.

NOTE: This equipment has been tested and found to comply with the limits for a Class B digital device, pursuant to Part 15 of the FCC Rules. These limits are designed to provide reasonable protection against harmful interference in a residential installation. This equipment generates uses and can radiate radio frequency energy and, if not installed and used in accordance with the instructions, may cause harmful interference to radio communications.

However, there is no guarantee that interference will not occur in a particular installation. If this equipment does cause harmful interference to radio or television reception, which can be determined by turning the equipment off and on, the user is encouraged to try to correct the interference by one or more of the following measures:

- Reorient or relocate the receiving antenna.
- Increase the separation between the equipment and receiver.
- Connect the equipment into an outlet on a circuit different from that to which the receiver is connected.
- Consult the dealer or an experienced radio/TV technician for help.

This equipment complies with FCC radiation exposure limits set forth for an uncontrolled environment. The device can be used in portable exposure condition without restriction.