

Panasonic®

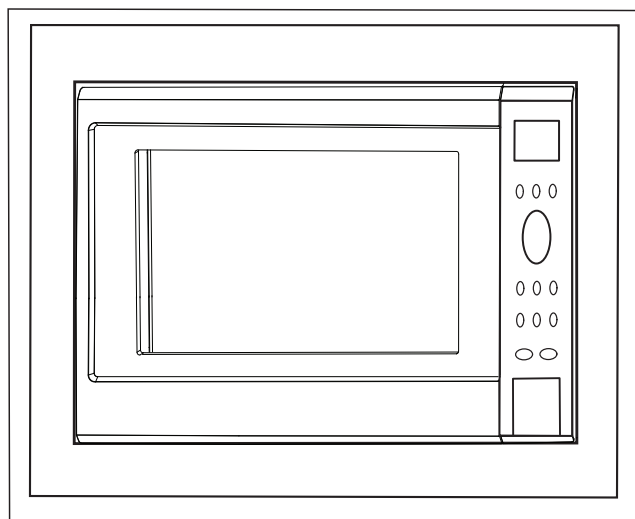

Installation Instructions

	Trim kit
24" cabinet (596 mm)	TK712SSQP TK712SWQP

© Panasonic Appliances Microwave Oven (Shanghai) Co., Ltd. 2012

Contents

Attention	P1
Step 1. Unpacking list.....	P2
Step 2. Feature diagram.....	P3
Step 3. Cabinet Preparation	P4
Step 4. Microwave Oven Installation	P5
Step 5. Cabinet Installation.....	P6-7
Step 6. Finishing Installation.....	P8-10

1. This trim kit can be installed into a cabinet. The cabinet opening must have the following internal dimensions as shown in **fig 1, p 4**.

A vent is required at the rear of the cabinet. It should travel the full height of the cabinet and the cabinet should not be obstructed. Minimum dimension of vent: 45 mm x 600 mm (**fig 1, p 4**).

MINIMUM INSTALLATION HEIGHT 850 MM.

2. Electrical Connections The appliance is supplied with a mains plug attached and should only be connected into an earthed socket that has been installed according to the relevant safety regulations.
If the plug is no longer accessible after the appliance has been built into the cabinet, a dual pole isolator must be installed to conform to the relevant safety standards.
3. Appliance shall be provided with means for disconnection from the supply mains having a contact separation in all poles that provide full disconnection under overvoltage III conditions, such means must be incorporated in the fixed wiring in accordance with the wiring rules and accessible.
4. It is essential that the cabinet is fixed to the wall for stability. The shelf must be able to support a weight of 30 kg.
5. If the microwave oven is to be removed from the kitchen cabinet and used free standing, the built in parts must be removed, and the oven returned to its original condition. Keep these installation instructions for future reference so the installation process can be reversed.

TAKE CARE NOT TO KINK OR TRAP THE MICROWAVE ELECTRICAL CABLE.







The diagram may vary from the actual unit and is only for your reference.

Step 1. Unpacking list

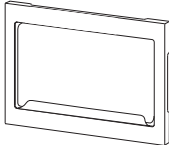
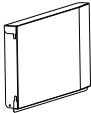
Tools Needed

- Measuring tape
- Pencil
- Driver
- Ø2 drill

Parts Supplied

	PART	QUANTITY
	Trim Frame	1
	Left Duct	1
	Rail	2
	Bracket	4
	Catch	4
	Tape	2
	Screw	12
	Strike	4

Step 2. Feature diagram

Installed Image

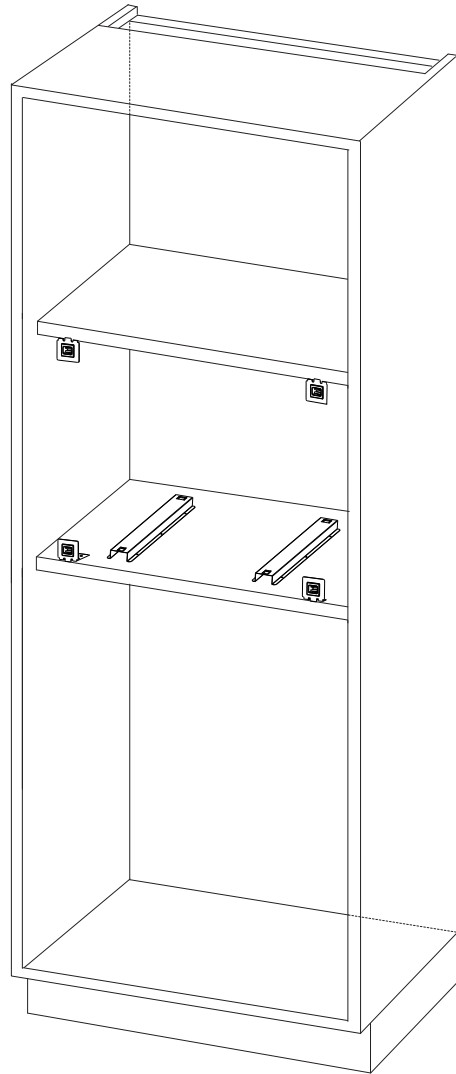
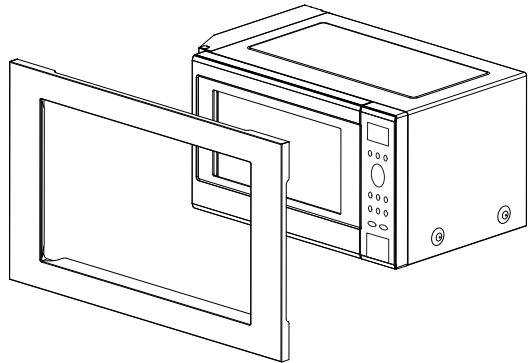

	Trim kit Dimensions
Width	596 mm
Height	410 mm
Depth	20 mm (Thickness)

Step 3. Cabinet Preparation

fig 1.

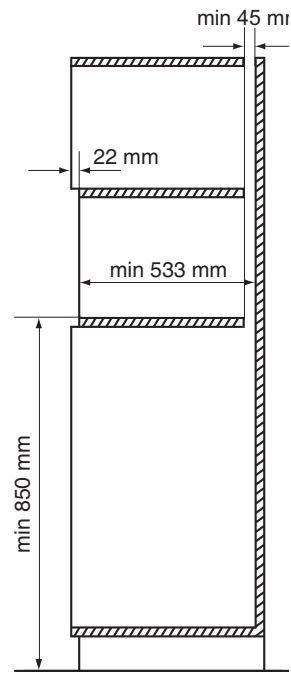
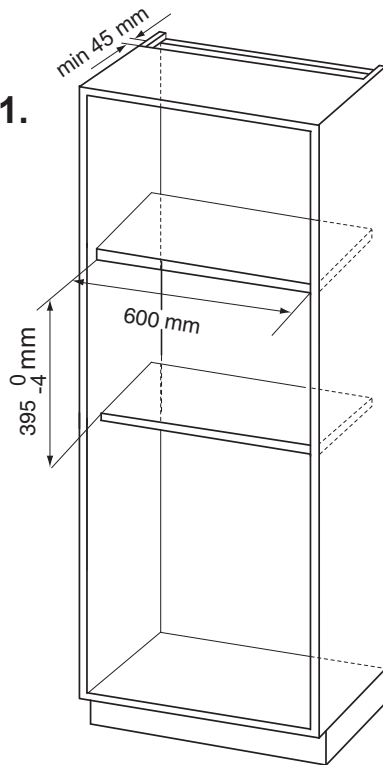
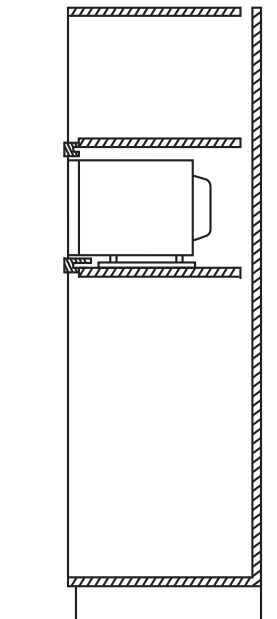
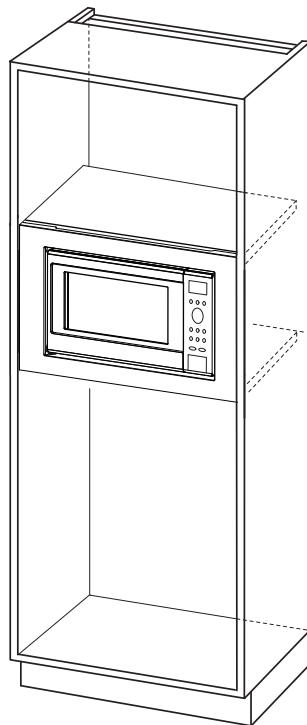
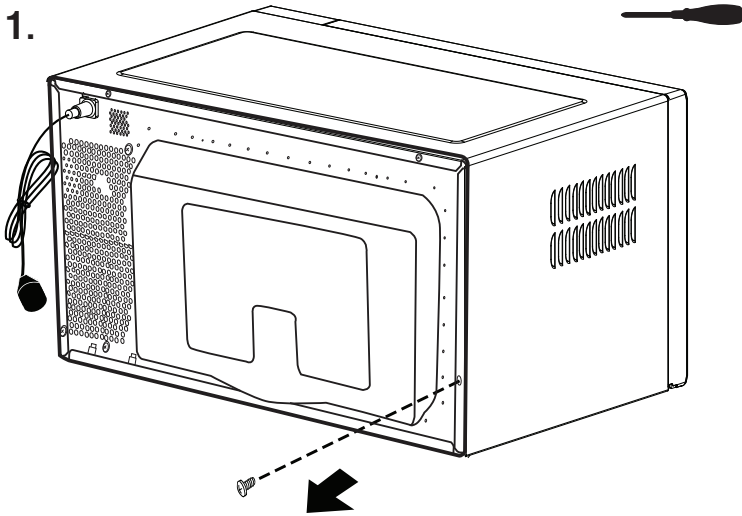

fig 2.



Step 4. Microwave Oven Installation

1.



2.

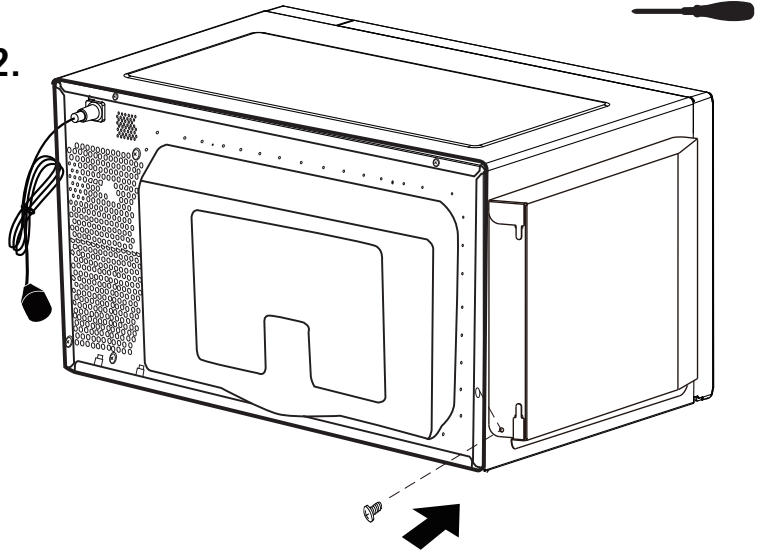

3.

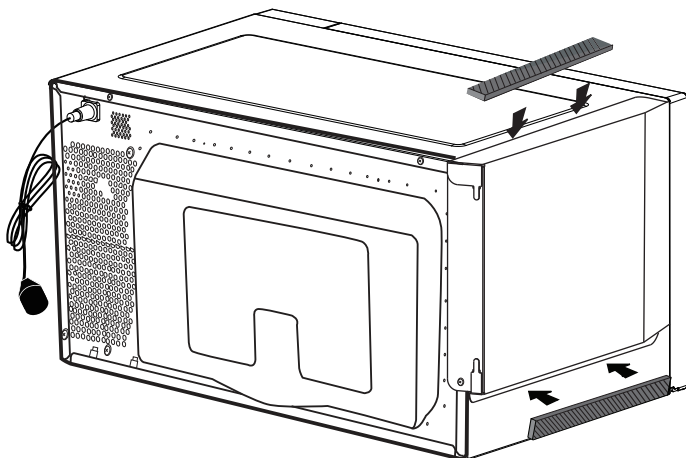

Put a piece of the tape on top of oven and left duct and put a piece of the tape on side of oven and left duct.

Step 5. Cabinet Installation

1. Aligning the rails

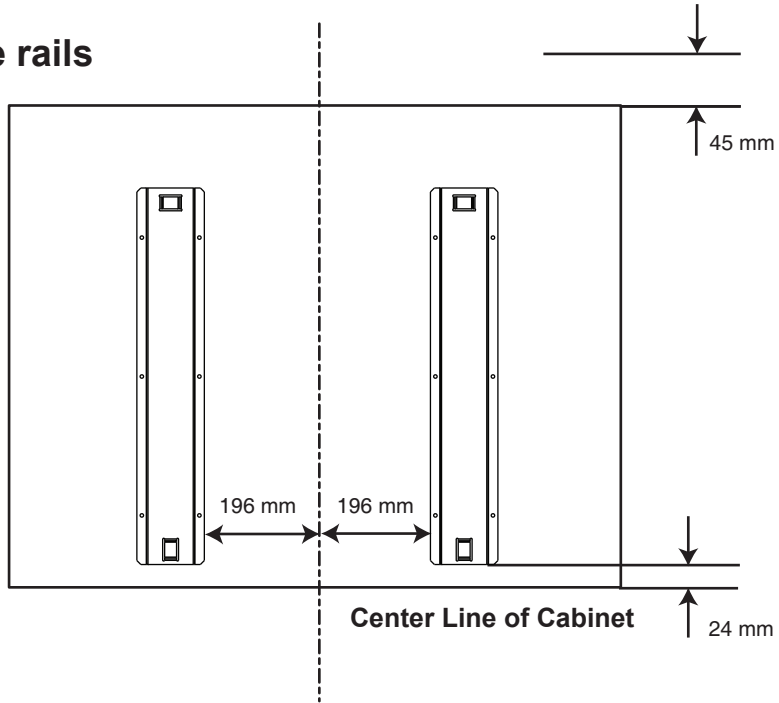

2. Attaching the rails

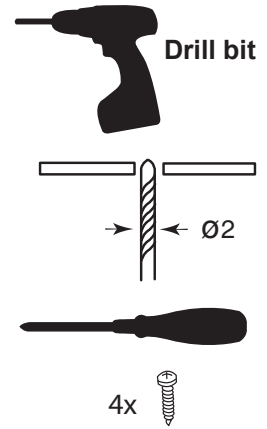
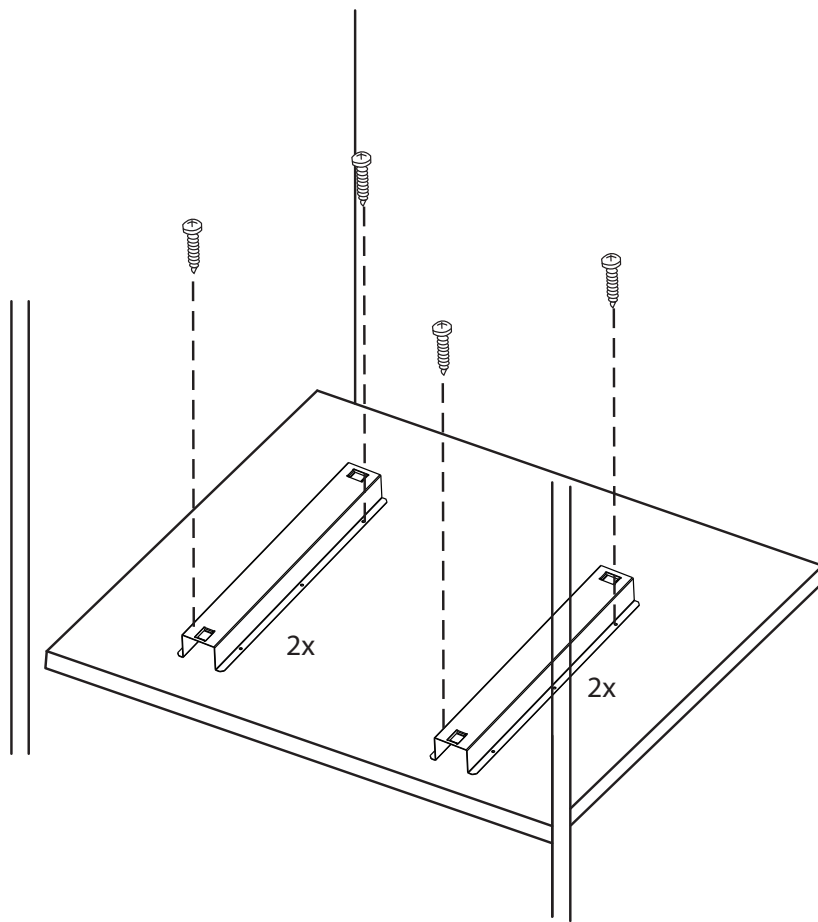

Step 5. Cabinet Installation

3. Bracket assembly

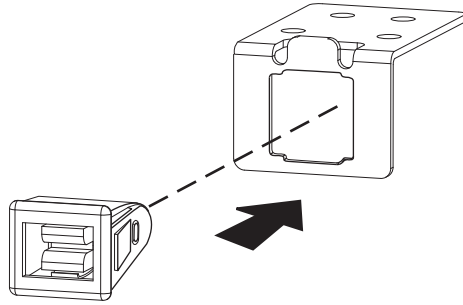

4. Attaching the bracket

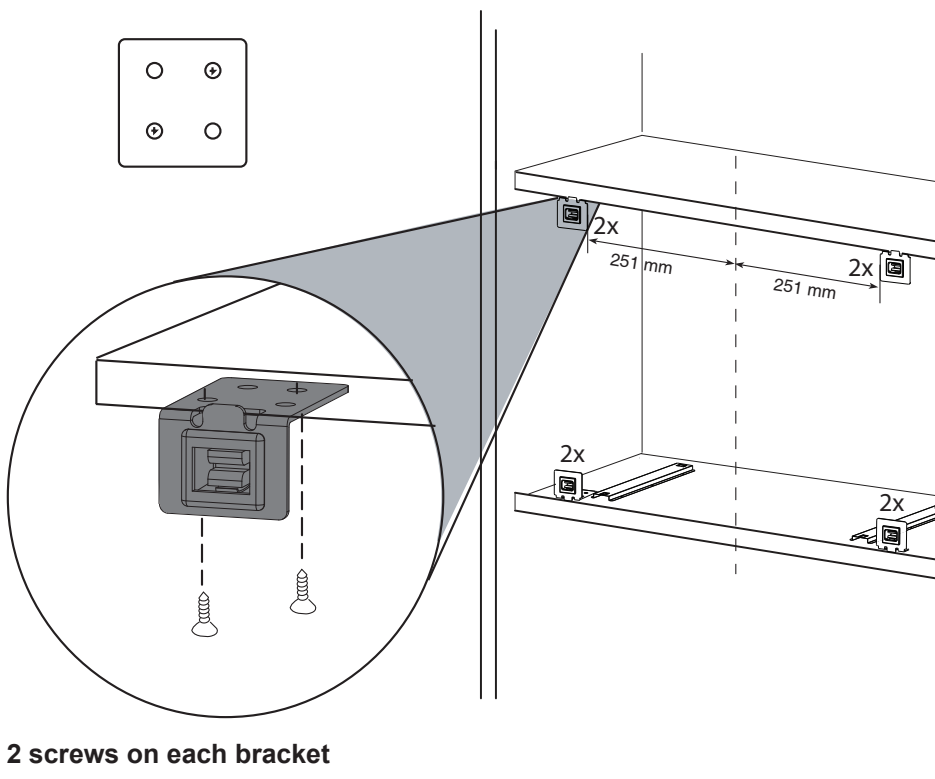
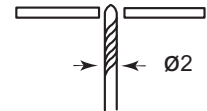

Step 6. Finishing Installation

Trim Frame

1. Inserting strikes

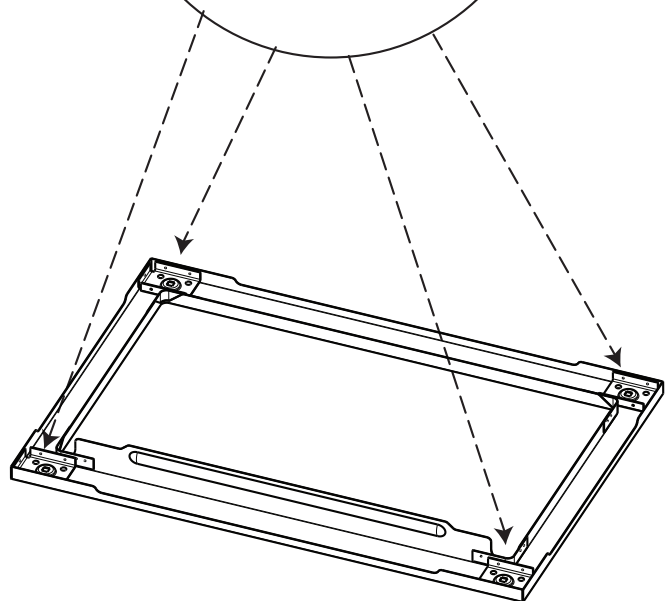
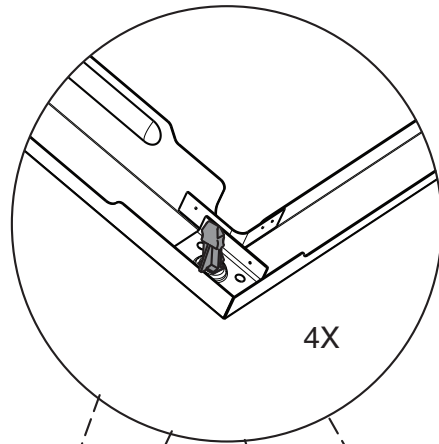
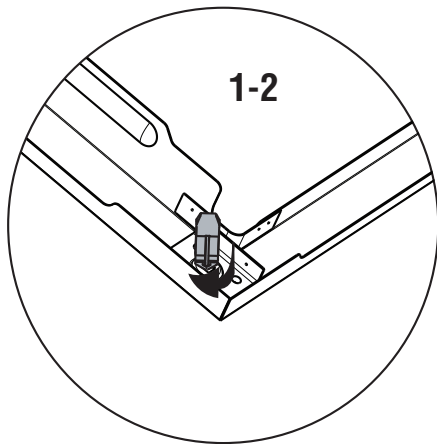
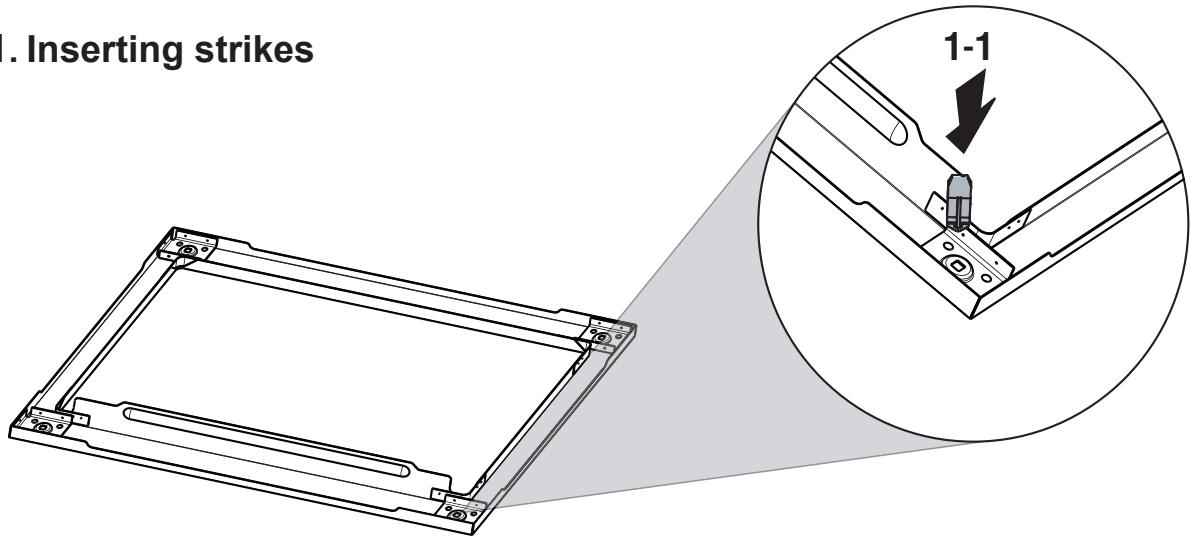

Step 6. Finishing Installation

Complete the assembly

2. Oven placement

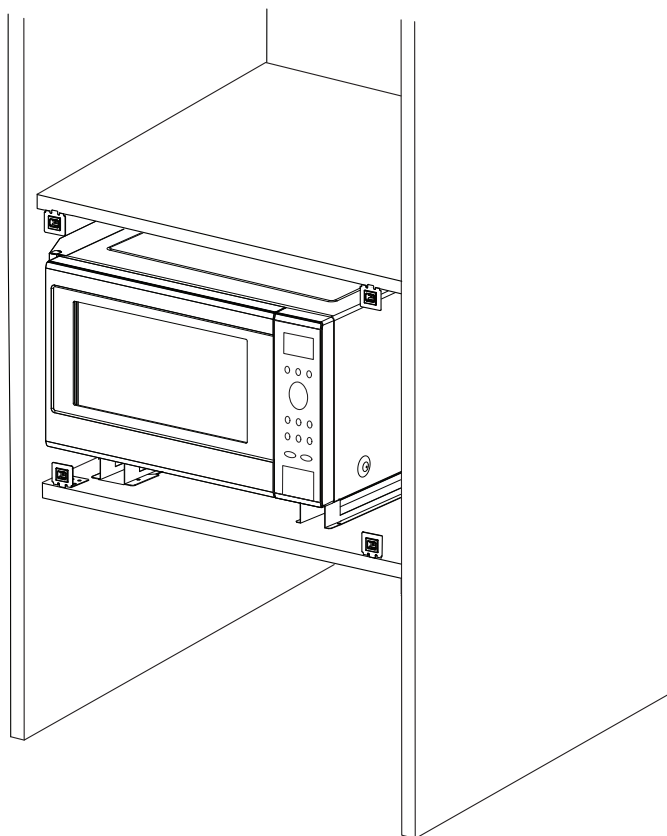
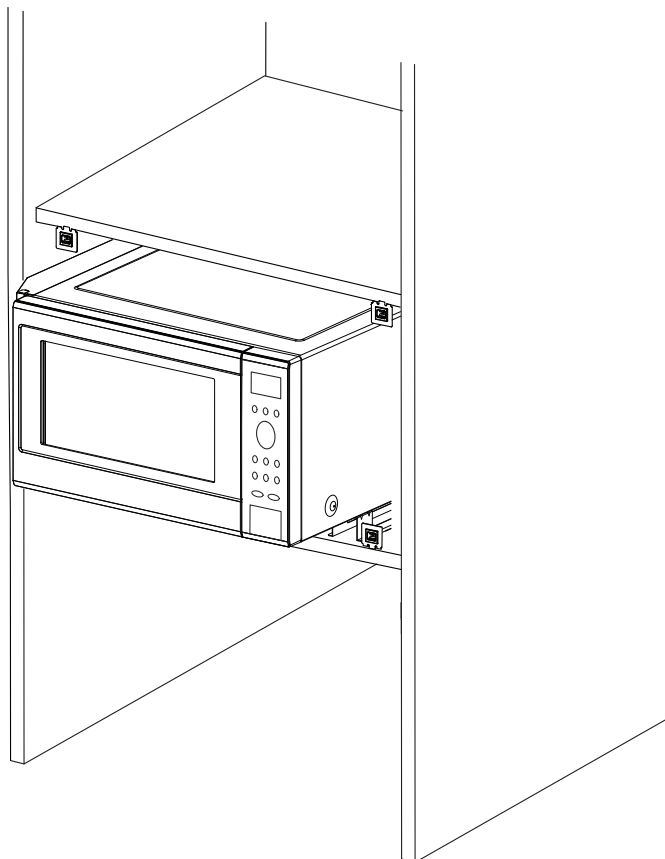

Step 6. Finishing Installation

Complete the assembly

3. Trim frame installation

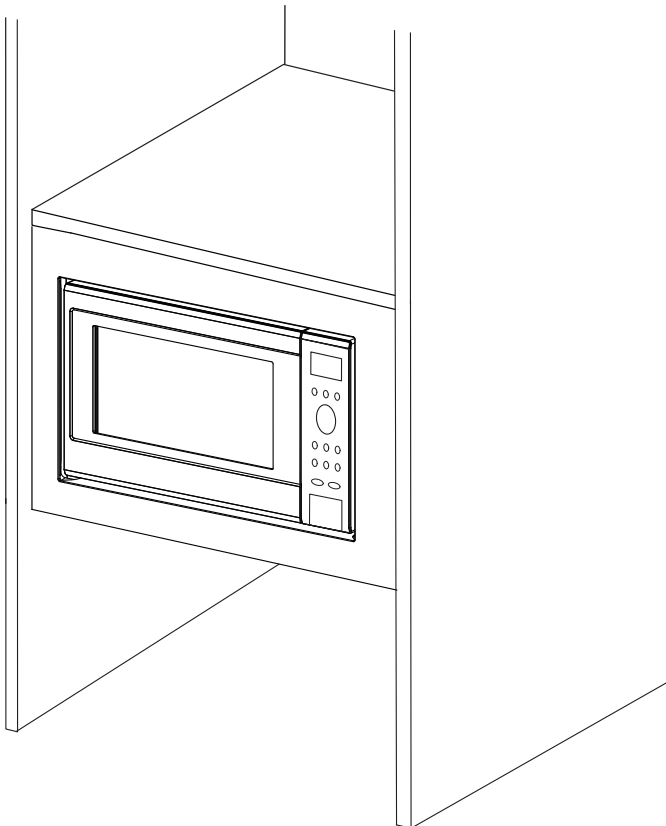
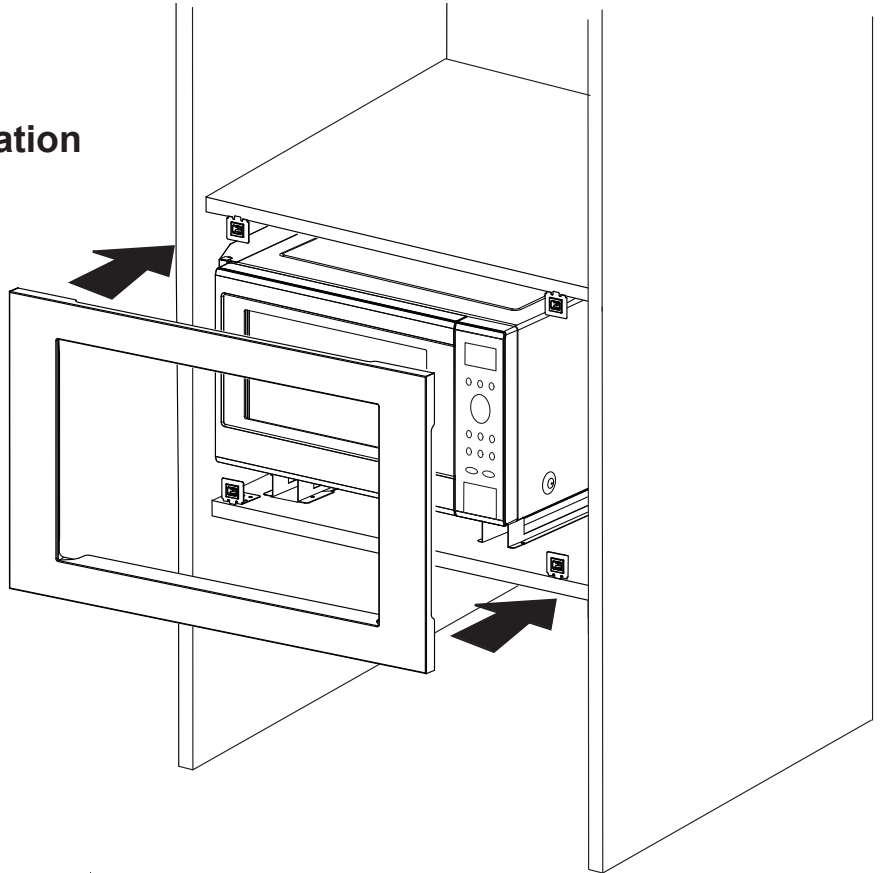

F0313BE90QP
IP0812-0
Printed in China