



INSTRUCTION MANUAL

Airfryer Toaster Oven
MCOV-2050

TABLE OF CONTENTS

Important safeguards	3
Getting to know your airfryer toaster oven	5
• Main component	5
• Features	6
• Technical specifications	6
• LED control panel	7
Before using your airfryer toaster oven	9
Operation guide	10
Cooking functions quick reference chart	12
Replacing the light	13
Care, Cleaning & Storage	14
Troubleshooting	16
Recipes table of contents	18
Notes	31

IMPORTANT SAFEGUARDS

Always follow basic safety precautions when using your Air Fryer Toaster Oven.

READ ALL INSTRUCTIONS BEFORE USE

- Unplug from outlet when not in use and before cleaning. Allow to cool before cleaning or handling, putting on or taking off parts.
- **Do not** touch hot surfaces without using heat-protective gloves. To avoid burns, use extreme caution when removing hot accessories or disposing of hot grease.
- **Do not** immerse cord, plug or any parts of Air Fryer Toaster Oven in water or other liquid to prevent against electrical hazard. This appliance should not be used by or near children.
- **Do not** operate any appliance with a damaged cord or plug. If the appliance is dropped or damaged, please return product to original store or retailer for proper inspection and repair.
- To avoid potential injury, do not use accessories or attachments not recommended for the unit.
- **Do not** use outdoors.
- **Do not** let the cord hang over the edge of a surface where the potential of child or pet interaction is present.
- **Do not** place on or near a hot gas or electric burner.
- **Do not** use this appliance for other than intended use.
- Extreme caution should be exercised when using containers constructed of materials other than metal or glass in the Air Fryer Toaster Oven.
- **Do not** store any materials other than manufacturer's recommended accessories in this appliance when not in use.
- **Do not** place any of the following materials in this appliance: cardboard, plastic, paper, or anything similar.

IMPORTANT SAFEGUARDS

- **Do not** cover Crumb Tray or any part of the Air Fryer Toaster Oven with metal foil. This will cause overheating of the Air Fryer Toaster Oven.
- Oversized foods, metal foil packages or utensils must not be inserted in an Air Fryer Toaster Oven as they may involve a risk of fire or electric shock.
- A fire may occur if the appliance is covered or touching flammable materials such as curtains, draperies or walls when in operation. Do not store any items on top of the appliance when in operation. Do not operate under wall cabinets.
- **Do not** clean with metal scouring pads. Pieces can break off the pad and touch electrical parts, involving a risk of electric shock.
- **Warning:** To avoid possibility of fire, **Never** leave the appliance unattended during use. Use recommended temperature settings for all function.
- **Do not** rest cooking utensils or baking dishes on glass door.
- **Do not** operate your appliance in an appliance garage or under a wall cabinet. When storing in an appliance garage, always unplug the unit from the electrical outlet.
- Check if the voltage indicated on the appliance corresponds to the local main voltage before connecting the appliance.

FOR HOUSEHOLD USE ONLY
SAVE THESE INSTRUCTIONS

GETTING TO KNOW YOUR AIR FRYER TOASTER OVEN

MAIN COMPONENTS



Oven Rack: Used for meat, bread, pizza etc.

Air Fryer Basket: Use the Air Fryer Basket in conjunction with the AirFry function to optimize your cooking results. Used for fries, chicken wings, onion etc. It also could be used as the dehydrate basket.

Baking Pan: Used for cookies, cake, turkey etc. It can also hold the drippings from the food or oil when Airfrying.

Oven Light: Press the “Light” button to turn on or turn off light. In order to save energy, the light will turn off automatically in 5 minutes, and re-press “Light” button if want to turn on the light once again.

FEATURES

By using all-new 360° HOT AIR CIRCULATION technology, The Air Fryer Toaster Oven can offer you more delicious and healthier cuisine.

DOOR SENSOR

If the door is opened during cooking, the cooking will pause and the light will turn on. When the door is closed, the light will turn off and resume cooking. Please make sure to keep the oven door closed during cooking.

CORD STORAGE

The built-in cord storage design, located in the back of the unit, takes up excess cord length and keeps your countertop looking clean and organized.

TECHNICAL SPECIFICATIONS

Power Supply	Rated power	Capacity	Unit size
120V, 60Hz	1800W	25L	450*400*375mm

LED Control Panel

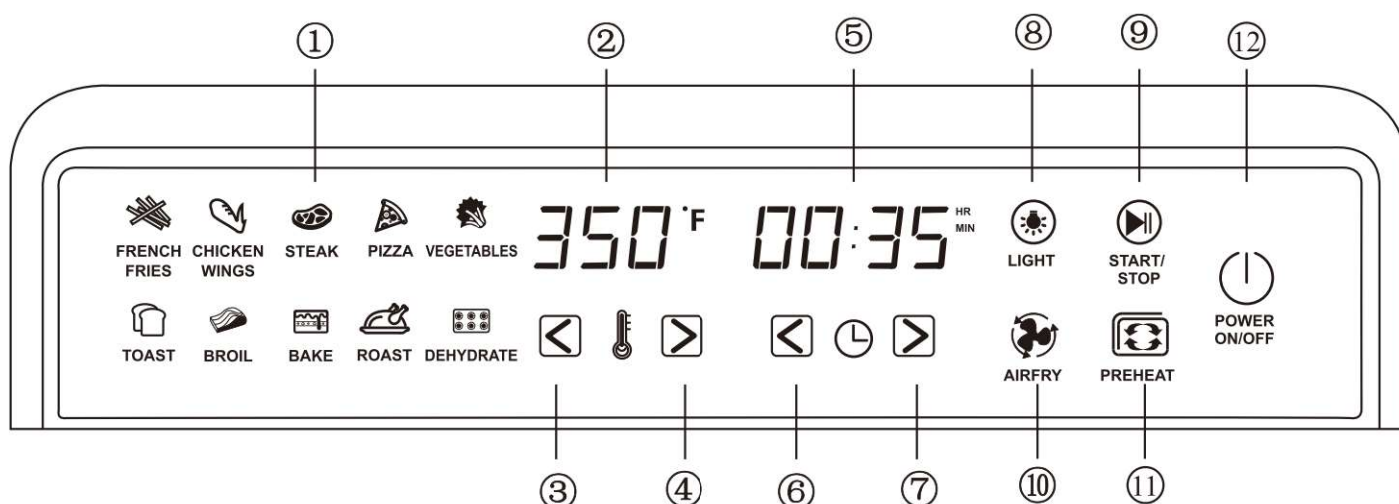

① AirFryer Toaster Oven Functions Overview

PRESET	ICONS	DEFAULT TEMPERATURE	DEFAULT TIME	TEMP RANGE	TIME RANGE
FRENCH FRIES		450°F	25MINS	100-450°F	Up to 2:00 HRS
CHICKEN WINGS		450°F	18MINS	100-450°F	Up to 2:00 HRS
STEAK		450°F	7MINS	100-450°F	Up to 2:00 HRS
PIZZA		400°F	11MINS	100-450°F	Up to 2:00 HRS
VEGETABLES		450°F	15MINS	100-450°F	Up to 2:00 HRS
TOAST		450°F	4MINS	LIGHT 1 MED 2 DARK 3	LIGHT 4MINS MED 5MINS DARK 6MINS
BROIL		450°F	10MINS	100-450°F	Up to 2:00 HRS
BAKE		350°F	20MINS	100-450°F	Up to 2:00 HRS
ROAST		400°F	30MINS	100-450°F	Up to 2:00 HRS
DEHYDRATE		120°F	4:00HRS	100-180°F	1-12:00 HRS

LED Control Panel

The above default data are for reference only, the user can adjust the desired temperature and time as required.

② DISPLAY:TEMPERATURE

③ **TEMPERATURE DECREASE:**

Touch "Temperature decrease" icon to decrease the temperature as needed. Long press the icon for rapid decrease operation of setting.

④ **TEMPERATURE INCREASE:**

Touch "Temperature increase" icon to increase the temperature as needed. Long press the icon for rapid increase operation of setting.

⑤ DISPLAY:TIME

⑥ **TIMER DECREASE:**

Touch "Timer decrease" icon to decrease the time as needed. Long press the icon for rapid decrease operation of setting.

⑦ **TIMER INCREASE:**

Touch "Timer increase" icon to increase the time as needed. Long press the icon for rapid increase operation of setting.

⑧ **LIGHT SWITCH**

Touch "LIGHT" icon to turn the oven light On/Off. (After manual selection, it will automatically turn off 5 minutes later)

⑨ **START/STOP**

Touch "START/STOP" icon to start or cancel the program.

⑩ **AIRFRY**

The "AIRFRY" icon indicates if the Air Fryer Toaster Oven is currently cooking or complete. The icon will flash when cooking and will stop flashing when cooking is complete or if the oven door is open.

⑪ **PREHEAT**

Touch "PREHEAT" icon to preheat the Air Fryer Toaster Oven. (No need to touch the "START/STOP" icon to enter the preheat program)

⑫ **POWER ON/OFF**

Touch "POWER ON/OFF" icon to turn the Air Fryer Toaster Oven On/Off.

BEFORE USING YOUR AIR FRYER TOASTER OVEN

1 Remove all packaging around and inside the oven.

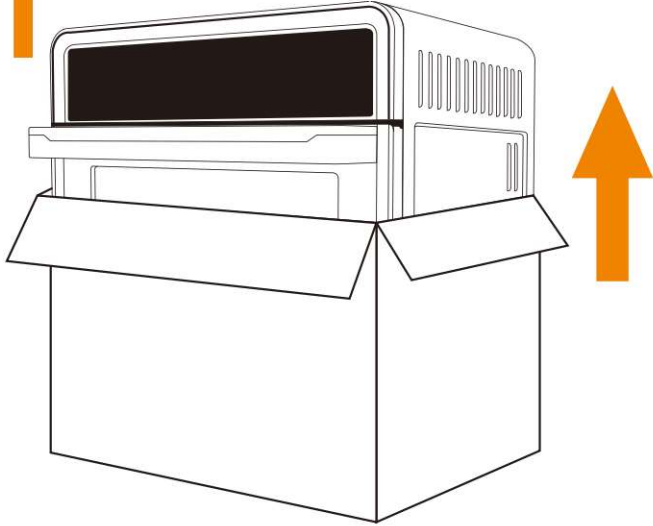

2 Place on a stable, level, heat-resistant surface, away from anything that can be damaged by heat. Keep at least 110 mm distance between the electrical outlet and the wall, furniture, etc.

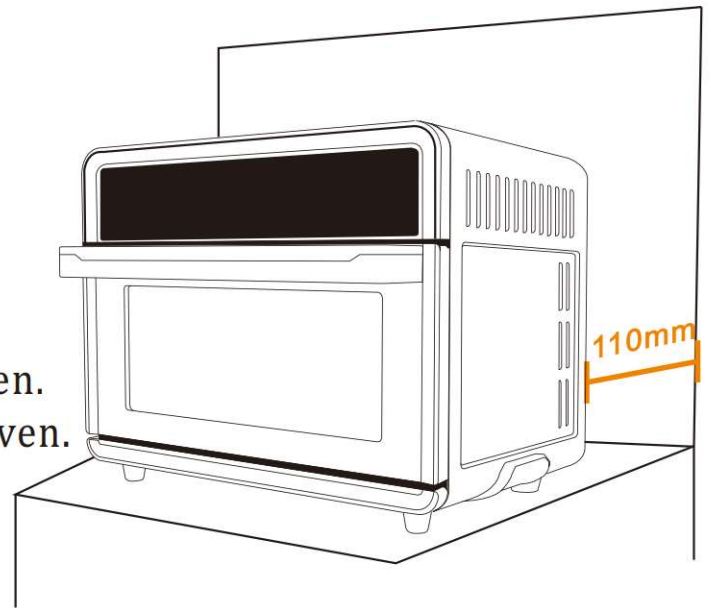

3 Wash all accessories and clean the interior of the Air Fryer Toaster Oven. Dry and place accessories back in oven.

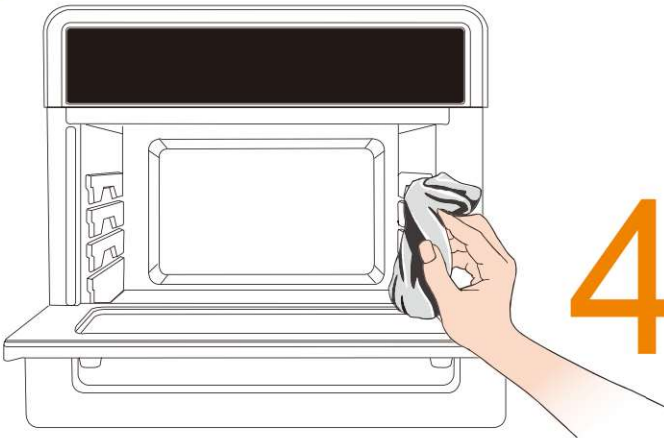

4 Before use, ensure that the power and outlet meet the requirements to operate this product (input power requirements).

5 Upon first use, it is necessary to run the oven for 18 minutes at the highest temperature (450°F) in order to sterilize and remove any manufacturing odor. The Air fryer Toaster Oven may emit an odor or smoke due to the heater's protective film.

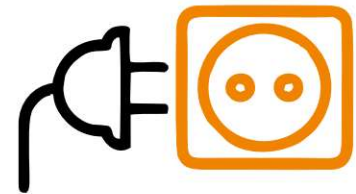

OPERATION GUIDE



POWER ON → Function → Preheat → Accessories position → START



Plug in, touch the POWER ON/OFF to turn on the Air Fryer Toaster Oven, screen will illuminate and “French Fries” Icon will blink.



Touch the desired menu icon gently to select the menu, screen will display the default temperature and default time for this menu, users can also adjust the temperature and time as desired.

Note: The temperature on the “Toast” function cannot be adjusted. The “TEMP” icon will adjust the time duration for light, medium, or dark toast.”



Touch the “PREHEAT” icon in order to preheat the Air Fryer Toaster Oven (No need to touch the “START/STOP” icon in order to begin preheating). When the internal temperature reaches 300 °F, the “Add Food” signal will appear.

Note: The Toast and Dehydration options do not require preheating.

OPERATION GUIDE

<p>Position1: DEHYDRATE</p>	<p>Position2: TOAST DEHYDRATE</p>
<p>Position3: TOAST DEHYDRATE BAKE VEGETABLES PIZZA</p>	<p>position2: FRENCH FRIES CHICKEN WINGS</p>
<p>position4: ROAST</p>	<p>Accessories</p> <p>Oven Rack AirFryer Basket Baking Pan</p>

Note: When cooking fatty foods (e.g. chicken wings) with the oven rack or the air fryer basket, place the baking pan in the slot underneath in order to prevent oil from dripping on to the stainless-steel heater.

4 Accessories position

5 START/STOP



Insert the accessories with food into the desired position then close the door. There are four groove positions, please to the above rack position diagrams to place the accessories.

Touch the START/STOP icon to begin cooking, and the display will show the timer counting down. The oven will beep 5 times, the display will show "END", and all menu icons will light up.

Note : The display will continue to show "END" until the menu icon is pressed. After cooking is complete, the fan will continue to run for 2 minutes in order to properly cool the appliance.

Cooking Functions Quick Reference Chart

FUNCTION	PREHEAT	Suggested Amount of Food	Suggested Accessory	Suggested Rack Position
French fries	Yes	980g	Air Fryer Basket	2
Chicken Wings	Yes	1038 g (21wings)	Air Fryer Basket	2
Steak	Yes	190 g	Baking Pan or Oven Rack	2
Pizza	Yes	12 inches	Baking Pan or Oven Rack	3
Toast	No	6pcs	Oven Rack	2or3
Vegetables	Yes	base on the food you select	Baking Pan or Oven Rack	3
Bake	Yes		Baking Pan or Oven Rack	3
Broil	Yes		Baking Pan or Oven Rack	2
Roast	Yes		Baking Pan or Oven Rack	4
Dehydrate	No		Oven Rack	1or2or3

Some moisture may occur on your oven door during the cooking process, this is a normal occurrence. For best results, we recommend you preheat the Air Fryer Toaster Oven before cooking.

REPLACING THE LIGHT

ATTENTION: Be sure to unplug the Air Fryer Toaster Oven and allow it to cool completely before replacing the oven light.

SPECIFICATION: 25W halogen bulb

1. Rotate the light cover counterclockwise to remove it.

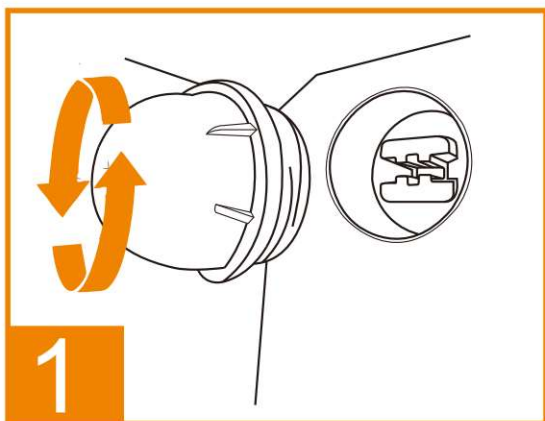

2. Remove the used bulb by pulling it directly.

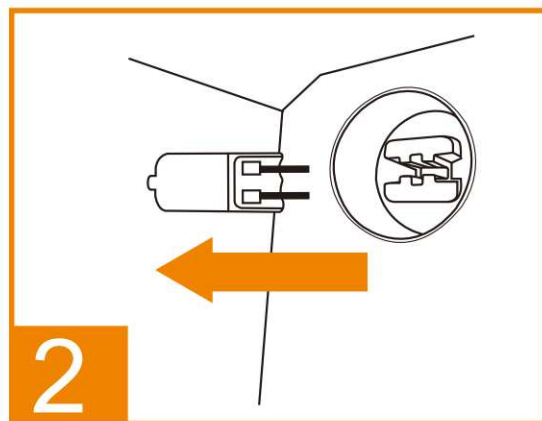

3. Insert the new bulb

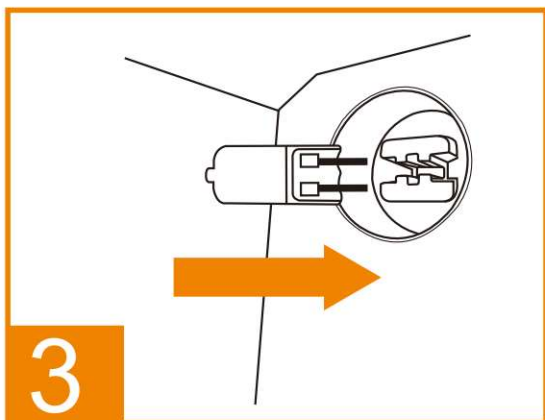

4. Rotate the light cover clockwise to tighten it.

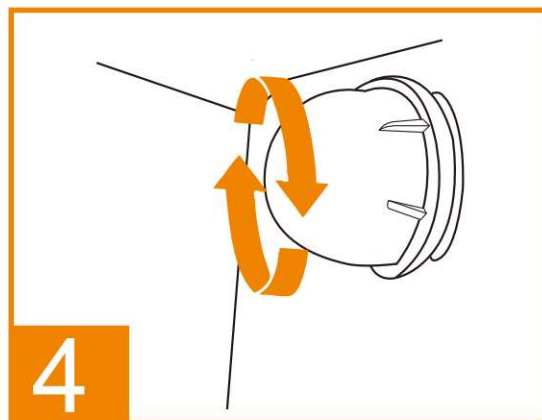

CARE, CLEANING & STORAGE

Before cleaning, remove the power plug from the power outlet. Allow the oven and all accessories to cool completely before disassembling and cleaning.

Cleaning the outer body and door

- Wipe the outer body with a soft, damp sponge. A non-abrasive liquid cleanser or mild spray solution may be used to avoid build-up of stains. Apply the cleanser to the sponge, not the oven's surface, before cleaning.
- To clean the glass door, use a glass cleaner or mild detergent and a soft, damp sponge or soft plastic scouring pad. Do not use an abrasive cleanser or metal scouring pad as these will scratch the oven's surface.
- Wipe the LED screen with a soft, damp cloth. Apply cleanser to the cloth, do not apply cleanser directly on to the LED. Cleaning the LED screen surface with a dry cloth and/or abrasive cleaners may produce scratches.



WARNING: To prevent electrocution, do not immerse the appliance or power cord into water or any other liquid.

Cleaning the interior

- To clean any spattering that may occur while cooking, wipe the walls with a soft, damp sponge. A non-abrasive liquid cleanser or mild spray solution may be used to avoid build-up of stains. Apply the cleanser to the sponge, not the interior, before cleaning.



WARNING: Use extreme caution when cleaning the heating elements. Allow the oven to cool completely, and then gently rub a soft, damp sponge or cloth along the length of the heating element. Do not use any type of cleanser or cleaning agent. Let all surfaces dry thoroughly prior to inserting the power plug into a power outlet and turning the oven on.

Cleaning the crumb tray

- After each use, slide out the crumb tray and discard crumbs. Wipe the tray with a soft, damp sponge. A non-abrasive liquid cleanser or mild spray solution may be used to avoid build-up of stains. Apply the cleanser to the sponge, not the tray, before cleaning. Dry thoroughly.

CARE, CLEANING & STORAGE

- To remove the baked-on grease, soak the tray in warm soapy water then wash with a soft sponge or soft plastic scouring pad. Rinse and dry thoroughly.
- Always ensure to re-insert the crumb tray into the oven after cleaning and prior to inserting the power plug into a power outlet and turning the oven on.

Cleaning the oven rack, dehydrate rack, baking pan and fry basket

- Wash all accessories in warm soapy water with a soft sponge or soft plastic scouring pad. Rinse and dry thoroughly. Do not use abrasive cleansers, metal scouring pads or metal utensils to clean any of the accessories as they may damage the surfaces.
- To extend the life of your accessories, cleaning them in the dishwasher is not recommended.

Storage

- Ensure the oven and all accessories are clean and dry.
- Ensure the door is closed.
- Store the appliance in an upright position, standing level and on its supporting legs. Do not store appliance when wet or hot. Do not store in a wet or hot environment.

Extension Cord :

- A short power-supply cord (or detachable power-supply cord) is provided to reduce the risk resulting from becoming entangled in or tripping over a longer cord.
- Longer detachable power-supply cords or extension cords are available and may be used if care is exercised in their use.
- If a longer detachable power-supply cord or extension cord is used:
 - 1) The marked electrical rating of the cord set or extension cord should be at least as great as the electrical rating of the appliance;
 - 2) The cord should be arranged so that it will not drape over the countertop or tabletop where it can be pulled on by children or tripped over unintentionally; and
 - 3) If the appliance is of the grounded type, the cord set or extension cord should be a grounding-type 3-wire cord.

TROUBLESHOOTING

Possible Problem	Possible Cause	Solution
The oven does NOT work	The appliance is not plugged in	Make sure the oven is plugged in.
	You have not turned on the oven	Press "ON/OFF" button to power on.
	The door is not closed properly	Make sure the door is closed well.
Steam is coming out from the top of the oven door	You are cooking high moisture content foods	This is normal. The door is vented to release steam created from high-moisture content foods such as frozen breads.
White smoke is coming out of the oven	This is the first time using the oven	This is normal upon first use. We suggest setting the oven to the highest temperature and letting it run empty from 18-20 minutes.
	You're cooking greasy food	This is normal when cooking greasy foods. This will not affect the cooking process.
	The baking pan, crumb tray, or heaters still contain grease or oil residue from previous use	Ensure each component is properly cleaned after each use.
Dark smoke is coming out of the oven	Food is burning	Immediately turn off the oven, be careful when you take out the food.

Possible Problem	Possible Cause	Solution
The ingredients cooked with the oven are not done	Too much food in the oven at once	Reduce the amount of food in the oven when cooking.
	Setting temperature too low or time too short	Set the temperature higher or time longer.
	Choose the incorrect function	Make sure you cook with the proper function.
Foods are cooked unevenly	Ingredients are stacked or close to each other during cooking	Make sure food and ingredients are spread out evenly.
	Baking pan, Air Fry basket or oven rack position is not adjusted	Adjust oven inserts into the proper position. Take caution as these components may be hot.
Foods are not crispy after Air Frying	Ingredients with high moisture	Spraying or brushing a small amount of oil on food evenly can increase crispiness.
Display shows Error Code "E1"	There is a short circuit in the temperature monitor	Remove the power cord from the power outlet. Contact Customer Support.
Display shows Error Code "E2"	The temperature monitor or heaters is inoperative	Remove the power cord from the power outlet, reconnect and operate again. If it cannot be solved, then Contact Customer Support.

Recipes

Table of Contents

Please refer to the rack position diagrams to place the accessories on page 11.

Chicken Wings	19
Sesame Ginger Sauce for Chicken Wings	19
White Pizza	20
Roasted Vegetables	20
Baked Sweet Potato	21
Bacon Wrapped Asparagus	21
Classic Roast Chicken	22
Kale Chips	22
Candied Bacon	23
Dried Apple Rings	23
French Fries	24
Sweet Potato Fries	24
Roasted Salmon	25
Onion Ring	26
Butter Cookies	26
Bagel	27
Egg Toast	28
Baked Pumpkin	28
Roasted Lamb Chops with Rosemary and Garlic	29
Bacon-Weaved Stuffed Turkey	30



18 MIN
TIME



450°F
TEMPERATURE

Chicken Wings

INGREDIENTS

Nonstick cooking spray

2 pounds (907 g) chicken wings, tips removed, drumettes and flats separated

¾ teaspoon (3.75 ml) kosher salt

DIRECTIONS

- 1 Spray the basket with the nonstick cooking spray.
- 2 Put the chicken wings into the basket. Sprinkle with salt.
- 3 Put the Air Fryer basket into rack Position 2. Set to Chicken wings at 450°F for 18 minutes. Cook until golden and crispy.



18 MIN
TIME



450°F
TEMPERATURE

Sesame Ginger Sauce Chicken Wings

INGREDIENTS

¼ cup (60 ml) sesame oil

2 garlic cloves, grated

6 green onions, thinly sliced

1 pc 2 inch (5 cm) piece ginger, peeled and grated

2 pounds (907 g) chicken wings, tips removed drumettes and flats separated

2 tablespoons (30 ml) honey

2 tablespoons (30 ml) soy sauce

¼ cup (60 ml) toasted sesame seeds

DIRECTIONS

- 1 Spray the basket with the nonstick cooking spray. Put the chicken into basket.
- 2 Put the Air Fryer basket into rack Position 2. Set to Chicken wings at 450°F for 18 minutes. Cook until golden and crispy.
- 3 Put the sesame oil, soy sauce, honey, ginger and garlic into a large bowl. Whisk together. Add the sesame seeds and green onions.
- 4 When chicken wings are ready, transfer wings to the large bowl and toss evenly. Serve immediately.



11 MIN
TIME



400°F
TEMPERATURE

White Pizza

INGREDIENTS

1 thin-crust pizza dough
½ tsp. red pepper flakes
¼ cup ricotta cheese

2 cloves garlic, sliced thinly
9 slices of fresh mozzarellas
Nonstick cooking spray

DIRECTIONS

- 1 Spray the baking pan with nonstick cooking spray, put the pizza dough on the pan, add ricotta, mozzarella, garlic and red pepper flakes.
- 2 Put the pan into rack Position 3 and set to Pizza at 400°F / 230°C for 11 minutes, or until the cheese is melted and lightly brown and the bottom crust is golden.
- 3 Let the pizza cool for 5 minutes before cutting.



15 MIN
TIME



450°F
TEMPERATURE

Roasted Vegetables

INGREDIENTS

1 Cucumber
10 mushrooms
2 tablespoons olive oil

1 Broccoli
1 onions, peeled
½ teaspoon salt

1 ear of corn
5 asparagus
1 teaspoon garlic powder

DIRECTIONS

- 1 Line the Baking Pan with aluminum foil.
- 2 Cut the vegetables into similar size pieces so they cook evenly.
- 3 Drizzle with olive oil and sprinkle with salt and garlic pepper.
- 4 Put the baking pan into the rack Position 3. Set to VEGETABLES at 450°F for 15 minutes.



35 MIN
TIME



450°F
TEMPERATURE

Baked Sweet Potato

INGREDIENTS

sweet potatoes

DIRECTIONS

- 1 Place the sweet potatoes on baking pan.
- 2 Put the baking pan into the rack Position 2. Set to VEGETABLES at 450°F for 35 minutes, or until soft.



10 MIN
TIME



450°F
TEMPERATURE

Bacon Wrapped Asparagus

INGREDIENTS

1 lb asparagus
Salt & Pepper

6 slices bacon
2 teaspoons Olive Oil

DIRECTIONS

- 1 Trim ends of asparagus so they are 5-6 inches long. Place in mixing bowl and toss with olive oil to coat. Season with salt and pepper.
- 2 Take 5-6 asparagus spears and one slice of bacon. Wrap the asparagus with bacon. Secure with toothpick if desired.
- 3 Place them in the baking pan with aluminum foil. Put the baking pan into the rack Position 3. Set to ROAST at 450°F for 10 minutes or until bacon is crispy and asparagus is cooked through.



40 MIN
TIME



400°F
TEMPERATURE

Classic Roast Chicken

Makes 4 to 6 servings

INGREDIENTS

- 1 lemon, halved
- 1 garlic cloves, smashed
- 1 teaspoon (5 ml) kosher salt
- ½ teaspoon (2.5 ml) freshly ground black pepper
- 2 teaspoons (10 ml) herbes de Provence or other dried herbs like rosemary and thyme

- 1 Whole chicken (4 pounds [1.8 kg])
- 1 teaspoon (5 ml) extra virgin olive oil

DIRECTIONS

- 1 Line the Baking Pan with aluminum foil.
- 2 Put the chicken dry and sprinkle with salt, half into the chicken's cavity. Put the chicken on the prepared baking pan and drizzle with olive oil. Rub with herbs and garlic cloves. Put the garlic
- 3 Put the Baking Pan with the chicken into rack position 4. Set Roast function at 400°F for 40 minutes. Cook until golden and crispy.

cloves into the chicken's cavity with the lemon.



5 MIN
TIME



350°F
TEMPERATURE

Kale Chips

Makes 4 servings

INGREDIENTS

- 4 stems curly kale, tough stems removed
- Olive oil, for spraying
- ¼ teaspoon (1 ml) kosher salt

DIRECTIONS

- 1 Evenly put the kale leaves on the AirFryer basket and spray liberally with oil.
- 2 Put the AirFryer Basket into the rack Position 2. Set to Bake at 350°F for 5
- 3 Once the kale is ready, remove from oven and sprinkle with salt. Serve immediately.

NOTE: Keep an eye on the kale because it can crisp it can crisp up very quickly.



4 HOURS
TIME



120°F
TEMPERATURE

Candied Bacon

INGREDIENTS

1 lb thick bacon
¼ tsp. ground cayenne pepper

¼ cup dark brown sugar
2 tbsp. maple syrup

DIRECTIONS

- 1 Evenly put the bacon strips on the oven rack.
- 2 Sprinkle the brown sugar and cayenne pepper over the bacon and rub into the meat. Brush the bacon with the maple syrup.
- 3 Put the oven rack into rack position 2. Set Dehydrate function at 120°F for 4 hours.



3-4 HOURS
TIME



120°F
TEMPERATURE

Dried Apple Rings

INGREDIENTS

1-2 Granny Smith Apples

DIRECTIONS

- 1 Using a pairing knife or a melon baller core the apple, then cut the apples into ¼ inch rounds.
- 2 Evenly put the slices on the oven rack. Put the oven rack into rack position 2. Set Dehydrate function at 120°F for 3 hours. You can also put additional slices on air fryer basket if using more than 1 apple.
- 3 Let the apples cool completely before transferring to an airtight container to store.



18MIN
TIME



450°F
TEMPERATURE

French Fries

Makes 2 to 3 servings

INGREDIENTS

1 pound (454g) russet potatoes
Some olive oil for spraying

1 teaspoon (5ml) kosher or seasoned salt

DIRECTIONS

- 1 Peel the potatoes and cut them into 1/4 inch (0.6cm) by 3 inch (7.6cm) strips.
- 2 Soak the potatoes strips in water for 30 minutes, then drain thoroughly and pat them dry with a paper towel.
- 3 Put the dried potatoes into the Air Fryer Basket. Spray liberally with oil. Sprinkle with salt and toss. Spread into a single layer.
- 4 Put the Air Fryer Basket into rack Position 2. Set to French Fries at 450°F for 18 minutes, cooking until desired crispiness is achieved.
- 5 When French fries are done, transfer to a serving bowl. Taste and adjust seasoning as desired. Serve immediately.



21MIN
TIME



450°F
TEMPERATURE

Sweet Potato Fries

Makes 2 to 3 servings

INGREDIENTS

Chipotle Mayonnaise:

½ cup (125 ml) mayonnaise
¼ teaspoon (1 ml) fresh lemon juice

1 chipotle chile in adobo, finely chopped

Sweet Potato Fries:

Olive oil, for spraying

½ teaspoon (2.5 ml) kosher salt

1 pound (454 g) sweet potatoes (about 2 medium), cut into ¼-inch (0.6 cm) thick pieces, about 4 inches (10 cm) long

DIRECTIONS

- 1 Prepare Chipotle Mayonnaise: stir mayonnaise, chipotle chile and lemon juice together in the bowl, then cover and refrigerate until ready to serve.
- 2 Make Sweet Potato Fries: Put the cut sweet potatoes into the Air Fryer basket. Spray liberally with oil. Sprinkle with salt and toss. Spread into a single layer.
- 3 Put the Air Fryer basket into the oven in rack Position 2. Set to French Fries at 450°F for 21 minutes. Cook until golden brown and crispy.
- 4 When sweet potatoes are ready, transfer to a serving bowl. Serve immediately with reserved Chipotle Mayonnaise on the side.



Roasted Salmon



4MIN
TIME



400°F
TEMPERATURE

This one-sheet dinner takes barely any time to prepare and cook.

Makes 2 servings

INGREDIENTS

- ½ pound (227 g) wild salmon
- 1 cup (250 ml) cherry tomatoes
- ½ bunch asparagus, trimmed
- ½ teaspoon (2.5 ml) kosher salt
- 1 garlic clove, sliced
- 1-2 tablespoons (15 to 30 ml) extra virgin olive oil
- ¼ teaspoon (1 ml) freshly ground black pepper
- ½ cup (125 ml) Kalamata olives, pitted and roughly chopped

DIRECTIONS

- 1 Line Baking Pan with aluminum foil. Put salmon, tomatoes, asparagus, olives and garlic onto the Baking Pan. Drizzle with olive oil and sprinkle with salt and pepper.
- 2 Put the Baking Pan with the salmon into rack Position 1. Set to Roast function with 400°F for 4 minutes, cook until salmon is opaque and vegetables are browned.



10MIN
TIME



400°F
TEMPERATURE

Onion Ring

INGREDIENTS

1 Onion 1 Egg
3 g Smoked Paprika

150 g All Purpose Flour
2 g ground pepper

3 g table salt
130 ml Milk

DIRECTIONS

- 1 Rinse the onion and cut into approximately $\frac{1}{4}$ inch rings. Carefully separate the rings from each other.
- 2 Line Baking Pan with aluminum foil. Brush foil with a layer canola oil, set aside.
- 3 Combine the flour, salt and paprika in a medium bowl and stir well.
- 4 Combine the egg, milk and salt in an other bowl and stir well.
- 5 First, coat each onion ring in the flour mixture. Second, coat each ring in the egg mixture, then coat rings in bread crumbs and transfer to baking pan .
- 6 Put the baking pan into the rackPosition2. Set to French Fries at 400°F for 10 minutes.



20MIN
TIME



350°F
TEMPERATURE

Butter Cookies

INGREDIENTS

2 tsp milk
1 tsp vanilla extract
2 large egg yolks

2 cups (283g) all-purpose flour $\frac{1}{4}$ tsp salt
 $\frac{2}{3}$ cup (140g) granulated sugar
1 cup(226g) unsalted butter, softened

DIRECTIONS

- 1 In the bowl of an electric stand mixer fitted with the paddle attachment cream together butter, sugar and salt until combined.
- 2 Mix in egg yolks and vanilla
- 3 Add flour and mix until crumbly then add in milk and continue to mix while adding in a little more milk if needed for a pipe-able consistency.
- 4 Transfer to a 16-inch piping bag fitted with a large open star tip. Pipe dough into rounds onto ungreased baking pan.
- 5 Preheat the oven, then put the baking pan into the rack position2. Set to Bake at 350°F for 20 minutes or until golden brown on bottom.



13MIN
TIME



450°F
TEMPERATURE

Bagel

INGREDIENTS

2 teaspoons active dry yeast

1 Egg

3 ½ cups bread flour + extra for kneading

1 ¼ Cups of warm water (1/4 additional water may be needed)

Favorite condiment such as sesame seeds, shredded cheese, coarse salt, etc.

1 ½ tablespoons granulated sugar

1 ½ teaspoons salt

DIRECTIONS

- 1 Add sugar and yeast to 1/2 cup warm water, stir, and let rest for 5 minutes.
- 2 Mix the flour and salt in a large bowl. Make a well in the center and pour in the yeast mixture, mix, then adding warm water a little bit at a time until the dough is moist but firm and slightly shaggy.
- 3 On a floured surface, knead the dough until it's firm and stiff, about 7 minutes, working in flour from surface.
- 4 Lightly brush a large bowl with oil and turn the dough to coat. Cover the bowl with a damp dish towel and let rest in a warm place until it's doubled in size, 1-2 hours.
- 5 Punch down the dough and let it rest for 10 minutes. Divide the dough into eight equal pieces, then shape each into a round.
- 6 Coat a finger in flour and press into the center of each dough ball to form a ring, stretching the ring into a bagel shape. Cover bagel shapes with a damp kitchen towel and allow to rest for 10 minutes.
- 7 Boil a large pot of water. Place bagels into boiling water by gently. Let bagels sit in boiling water for 1-2 minutes, then flip and allow to sit in water for an additional 1-2 minutes (the longer they are in the water, the chewier the texture will be).
- 8 Remove from water and place on airfryer basket brushed with oil. Brush bagels with egg wash (1 beaten egg plus 1 tablespoon water). Add condiment if desired.
- 9 Preheat the oven. Put the airfryer basket into the rack Position 2. Set to Vegetables at 450°F for 13 minutes.



Egg Toast



7MIN
TIME



450°F
TEMPERATURE

INGREDIENTS

2 Slice of Bread

Salt & Pepper

1 Large Egg

Butter

Shredded Cheese

DIRECTIONS

- 1 Using a spoon flatten out the center of your piece of bread then butter your bread.
- 2 Crack egg into flattened section of bread and sprinkle with salt and pepper.
- 3 Sprinkle shredded cheese around the egg on bread and egg white.
- 4 Carefully place egg bread in air fryer basket. Put the Air Fryer Basket into the rack Position2. Set to Toast function and choose the desired shade (Light, Med or Dark).



Baked Pumpkin



10MIN
TIME



450°F
TEMPERATURE

INGREDIENTS

Pumpkin

Olive oil

DIRECTIONS

- 1 Cut the pumpkin and brush with the olive oil.
- 2 Place the Pumpkin on baking pan. Put the baking pan into the rack Position2. Set to VEGETABLES at 450°F for 10 minutes or until soft.



**10MIN
TIME**



**450°F
TEMPERATURE**

Roasted Lamb Chops with Rosemary and Garlic

Makes 4 servings

INGREDIENTS

- 4 garlic cloves, crushed
- 1 tablespoons (30 ml) extra virgin olive oil
- ¼ teaspoon (1 ml) freshly ground black pepper
- 8 loin lamb chops, about 2 pounds (907 g)
- ½ teaspoon (2.5 ml) kosher salt
- 1 tablespoon (15 ml) chopped fresh rosemary (leaves from about 3 to 4 rosemary sprigs)

DIRECTIONS

- 1 Stir the garlic, rosemary, pepper and olive oil together in a bowl. Add the lamb chops and toss together well to fully coat. Let rest at room temperature for about 30 minutes. The lamb can also be marinated overnight in the refrigerator at this point for maximum flavour.
- 2 Line the Baking Pan with aluminum foil. Put the lamb chops on the pan and sprinkle evenly with the salt.
- 3 Put the Baking Pan into rack Position 2. Set Broil function with 450°F for 10 minutes. Let chops rest for about 5 minutes once removed from the oven before serving.



**20MIN
TIME**



**350°F
TEMPERATURE**

Bacon-Weaved Stuffed Turkey

INGREDIENTS

- 1 turkey breast, boneless
- 1 tsp. salt
- 1 tsp. ground black pepper
- 1 tablespoon (15 ml) olive oil
- 1 ½ cups cornbread stuffing, cooked
- 10 slices bacon

DIRECTIONS

- 1 Slice the turkey breast down the middle and open it to butterfly.
- 2 Make a weave with the bacon on wax paper.
- 3 Spoon the stuffing into the center of the turkey. Roll the turkey with the bacon, then brush the bacon with olive oil.
- 4 Place the butterflied turkey breast over the bacon weave. Season with the salt and ground black pepper.
- 5 Tie the ends and middle of the turkey with string.
- 6 Line the Baking Pan with aluminum foil. Put the turkey on the pan.
- 7 Put the Baking Pan into rack Position 3. Set Broil function with 350°F for 20 minutes. Serve with roasted asparagus.

NOTES
