

ZLINE

ATTAINABLE LUXURY[®]



User Manual

WINE REFRIGERATION RBCWVR-18, RBCWVL-18, & RBCWV-24 MODELS

www.zlinekitchen.com



ZLINE Kitchen and Bath provides Attainable Luxury, where the kitchen and bath of your dreams is never out of reach. Through our unique designs and unparalleled quality, we're dedicated to providing you an elevated experience in the heart of your home. With an endless selection of features and finishes, our inspiration is your reality.

ZLINE
ATTAINABLE LUXURY®



ZLINE is fueled by a passion for innovation; A relentless pursuit of bringing the highest end luxury designs and professional features into everyone's homes.

Because we continually strive to improve our products, we may change specifications and designs without prior notice.

Scan the QR code to view the most up-to-date version of the Installation Manual and User Manual.

⚠ WARNING: This product can expose you to chemicals including nickel, which is known to the State of California to cause cancer. For more information, go to www.P65Warnings.ca.gov.

TABLE OF CONTENTS

IMPORTANT SAFETY INSTRUCTIONS.....	1
OPERATION	9
MAINTENANCE AND CLEANING	18
TROUBLESHOOTING.....	21
WARRANTY.....	26

IMPORTANT SAFETY INSTRUCTIONS

PLEASE READ THIS MANUAL BEFORE INSTALLING AND USING THE PRODUCT

- Always follow the applicable safety instructions.
- The installer should leave these instructions with the consumer who should retain for local inspectors' use and for future reference.
- Please read all other documents provided with this product.
- Please keep in mind this manual may apply to several product models.
- This manual expressly indicates the differences between various models.
- **IMPORTANT:** This is a complex installation procedure that should only be performed by qualified professionals and technicians.
- The manufacturer will not be responsible for any damage to property or to persons caused by incorrect installation, improper use of the appliance, or failure to heed the warnings listed.

Symbols used in the installation manual are as follows.



Important information and useful hints.



WARNING

Conditions that may damage the product or its operating functions.



ATTENTION

Conditions containing serious injury risk.



CAUTION

Conditions containing electric shock risk.

IMPORTANT SAFETY INSTRUCTIONS



WARNING

R600A REFRIGERANT

This product contains R600a isobutane refrigerant, which is a very eco-friendly natural gas. However, it is also flammable. Please follow the warnings and installation instructions below:

- If the product has been transported horizontally, you must wait a minimum of 4 hours after standing it upright before plugging it in.
- Cut-out dimensions of the installation area must be suitable to safely fit the product for full installation.
- Dimensions, features, and position of objects used to support and affix the product to this area must be suitable.
- Minimum clearances between product parts and surrounding structures must be suitable.
- Minimum dimensions and proper organization of ventilation holes must be observed.
- The product must be connected to the main power outlet, and corresponding connections of other components must be suitable.
- The product must be able to be disconnected from the power supply if needed after installation.
- The outlet or fuse must be accessible to disconnect the product.
- Extension cables or ungrounded (two-terminal) adapters must not be used with this unit.



ATTENTION

You must wear gloves and eye protectors when installing the product.

You must also take measures against high noise levels when using a drill to drill into the floor or wall.



ATTENTION

Make sure that your product is suitable for your local codes.



ATTENTION

The product must be installed by a qualified technician according to the installation instructions.



WARNING

The product may tip over since it is quite heavy. For this reason, safety precautions must be taken. The door of the product must be kept closed until it reaches the final install destination, and it must be transported in accordance with the installation instructions.

IMPORTANT SAFETY INSTRUCTIONS

DISPOSING OF THE PACKAGING MATERIALS

- The package has been designed to protect the product during transport and shipping. The packaging materials used are designed to not harm the environment and should be recycled after the appliance is installed.
- All plastic packaging materials, bags, etc., must be disposed of safely and kept out of the reach of children.



This Installation Manual has been prepared to help qualified professionals with installation of the appliance. The User Manual provided with the product must also be taken into consideration, as it contains important information about operation and safety. You may get seriously injured and your product may get damaged if you ignore the warnings given in this manual. Please read the following carefully.



Risk of child entrapment. To avoid safety and suffocation risks for children or pets, before you dispose of the appliance, take off the door and drawers and leave the shelves in place so children or pets may not climb inside.

COMPLIANCE WITH THE WEEE DIRECTIVE AND DISPOSING OF E-WASTE

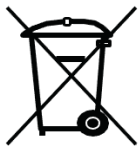

- This product conforms to the EU WEEE Directive (2012/19 EU).
 - This product bears a classification symbol for "waste electrical and electronic equipment," otherwise known as WEEE.
 - This product has been manufactured from high-quality parts and materials that can be reused and are suitable for recycling.
- Therefore, do not dispose of the product with normal domestic waste or other waste at the end of its service life.
 - Take it to a collection center for recycling electrical and electronic equipment.
 - Please consult your local government authority to learn about appropriate collection center location.

IMPORTANT SAFETY INSTRUCTIONS

INSTALLATION ENCLOSURE

You must follow the instructions below:

- The floor on which the product will be installed must be capable of bearing a minimum of 1,200 pounds (544 kilograms).
- The kitchen floor and bottom of the product must be at the same level. Otherwise, the air flow for the unit's cooling system may be impeded or reduced.
- There must be no objects preventing installation of the product to the back and side walls of the product's cut-out installation area.
- The electrical outlet receptacle must be properly located and easily accessed.
- Cut-out dimensions of the cabinets where the product will be installed must be in strict conformity with the dimensions given in the manual.
- Do not install the refrigerator directly adjacent to another refrigerator unless using the appropriate joining kit. Otherwise, condensation and damage may occur. (Please see "Dual Cabin Installation Methods" on page 11 of the Installation Manual for imagery)
- Check if the floor where the product will be installed is level. Use a level when doing so to be sure.
- The installation area must not be subjected to direct sunlight and it must be away from heat sources, such as microwaves, ovens, radiators, etc.
- The ambient temperature must be between 55 °F and 100 °F (13 °C and 38 °C), depending on where the unit is installed. Otherwise, functional errors may occur when the product is running.
- If it is not possible to avoid installing the product near a heat source, the minimum clearances given below must be maintained:
 - 2" (51 mm) from electric ranges or ovens.
 - 12" (305 mm) from gas or fuel operated ranges or ovens.

IMPORTANT SAFETY INSTRUCTIONS

Please observe the following rules:

- The dedicated circuit breaker for this unit must be easily accessible in case of an emergency; it must not be hidden behind the product.
- The electrical plug and cord must not touch the back surface of the product. Otherwise, it may get damaged due to the vibration of the product.
- Do not connect the plugs of other appliances behind this product.
- If the humidity level is high where the product is used, corrosion may occur on the outer surface of the product. Keep the area where the unit will be installed dry and well-cleaned to avoid corrosion.



CAUTION

To avoid the risk of electric shock:

- Connect the plug to a dedicated grounded electrical outlet.
- Do not remove the ground terminal of the plug.
- Do not use adapters.
- Do not use extension cables or cords.



ATTENTION

Do not install your refrigerator:

- In open areas.
- In environments where water is dripping.
- In environments where temperature is lower than 55 °F (13 °C).

IMPORTANT SAFETY INSTRUCTIONS



Failure to follow these instructions may result in death, fire, or electric shock. Connecting the grounding conductor of the equipment to an improper place may lead to electric shock. Please have the grounding checked by a qualified electrician or service technician.

Installation, repair, and other procedures performed by unqualified persons may cause danger. Before installing the appliance, make sure that the voltage, load, and circuit current parameters on the data plate are in compliance with the power mains in your house.

The appliance is provided with a NEMA 5-15P plug and a 3-pin power cable, which is UL listed and ready to be connected to a 120VAC, 60Hz power supply. The fuse is 15 amps, and the appliance must be connected to a dedicated electrical outlet.

If combining multiple units, ZLINE recommends all be plugged into independent circuits. They can be plugged into the same outlet, but the circuit must have a dedicated 15-amp breaker.

If the electrical wiring or power supply of the house needs alteration, the necessary procedures must be performed by a qualified electrician. The plug must be installed only by a licensed electrician.

CABINETS

- Make sure that the cabinets where you will install the appliance have been safely mounted in your kitchen. Your cabinets must be securely connected to the floor and walls properly and with suitable connections.
- For the best installation, clearances between the cabinets and the product must be in compliance with the values specified in the installation instructions of this manual.
- Side walls must be free of any obstructions and their surfaces must be flat.
- **NOTE:** Minimum thickness of the side walls is 5/8" (16 mm). The minimum thickness of the door to be attached to the product must be 3/4" (19 mm).

IMPORTANT SAFETY INSTRUCTIONS

VENTILATION

Ventilation panels where the air enters and exits the unit must not be blocked or obstructed. In addition, you must periodically clean the dust and dirt that accumulates on the vent holes to ensure adequate ventilation.

ELECTRICAL CONNECTION



CAUTION

RISK OF ELECTRIC SHOCK

Electrical grounding is necessary. This appliance is equipped with a 3-pin plug to protect you against possible electric shocks.

- Do not remove the round grounding terminal from the plug.
- Do not use 2-pin grounding adapters.
- Do not use extension cables or cords to energize the product.



ATTENTION

Do not connect the grounding cable to any gas pipes. Please have the grounding checked by a qualified electrician if you are not sure about the grounding of the product. Do not install a fuse on the neutral line or grounding circuit.



WARNING

Please wait 3-6 hours after installing the unit before plugging it in to protect it against possible damages. This way, the refrigerant and the lubricants in the system are given proper time to balance.

IMPORTANT SAFETY INSTRUCTIONS

- Never use an extension cable or cord with this unit.
- The dedicated electrical outlet receptacle for this unit must be grounded and checked by an authorized electrician.
- The location of the electrical wiring must comply with the dimensions specified in this installation manual.
- Check that the voltage marked on the product corresponds with your supply voltage.
- This appliance should be properly grounded for your safety. The power cord of this appliance is equipped with a three-pin plug which mates with standard three-pin wall outlets to minimize the possibility of electrical shock.
- Never under any circumstances cut or remove the third ground prong from the power cord supplied. For personal safety, this appliance must be properly grounded.
- Have the wall outlet and circuit checked by a qualified electrician to make sure the outlet is properly grounded. When a standard two-pin wall outlet is encountered, it is your responsibility and obligation to have it replaced with a properly grounded three-pin wall outlet.
- To prevent accidental injury, the cord should be secured behind the appliance and not left exposed or dangling.
- The appliance should always be plugged into its own individual electrical outlet which has a voltage rating that matches the rating label on the appliance. This provides the best performance and also prevents overloading wiring circuits that could cause a fire hazard from overheating. Never unplug the appliance by pulling the power cord. Always grip the plug firmly and pull straight out from the receptacle. Repair or replace immediately all power cords that have become frayed or otherwise damaged. Never use a cord that shows cracks or abrasion damage along its length or at either end. When moving the appliance, be careful not to damage the power cord.
- Never use your appliance with an extension cord unless this cord has been checked and tested by a qualified technician or service person. The extension cord must be a UL/CUL Listed, 3-wire grounding extension cord that has a grounding plug and outlet and that the electrical rating of the cord is 115 volts and at least 10 amperes.

OPERATION

PRODUCT SPECIFICATIONS

Description of Product	Wine Cooler
Model	RBCWVR-18/RBCWVL-18 series models
Voltage/Frequency	VAC 115/60Hz
Amperage	1.5A
Storage Capacity*	68 standard bottles or 62 Bordeaux-style bottles
Refrigerant	R600a
Temperature Range	41 °F – 68 °F (5 °C – 20 °C)
Dimensions	17 3/4" W x 23 5/16" D x 83 9/16" H (451 mm W x 597 mm D x 2130 mm H)

*Storage capacity is based on standard wine bottles and 750 ml Bordeaux-style wine bottles.

Internal storage options

Load capacity	Bottle storage (Bottle A)	
Upper zone	1	5
	2	5
	3	5
	4	5
	5	5
Middle zone	1	3
	2	5
	3	5
	4	5
Lower zone	1	5
	2	5
	3	5
	4	5
	5	5
Total	68	

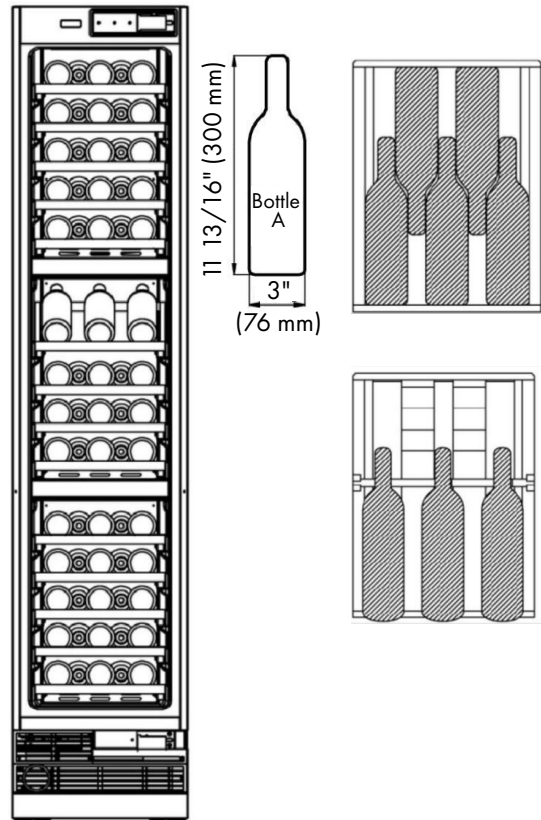

OPERATION

PRODUCT SPECIFICATIONS

Internal storage options

Load capacity		Bottle storage (Bottle A)	Bottle storage (Bottle B)
Upper zone	1	-	3
	2	5	-
	3	5	-
	4	5	-
	5	5	-
Middle zone	1	-	3
	2	-	3
	3	5	-
	4	5	-
Lower zone	1	-	3
	2	5	-
	3	5	-
	4	5	-
	5	5	-
Total		50	12

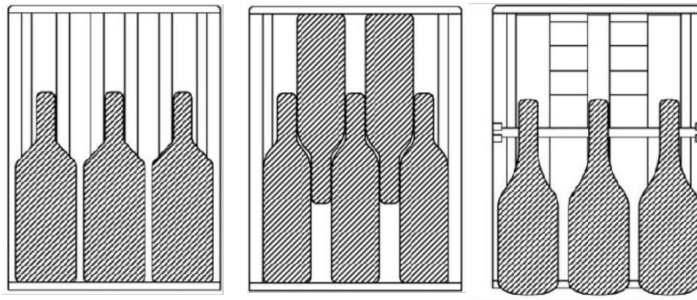
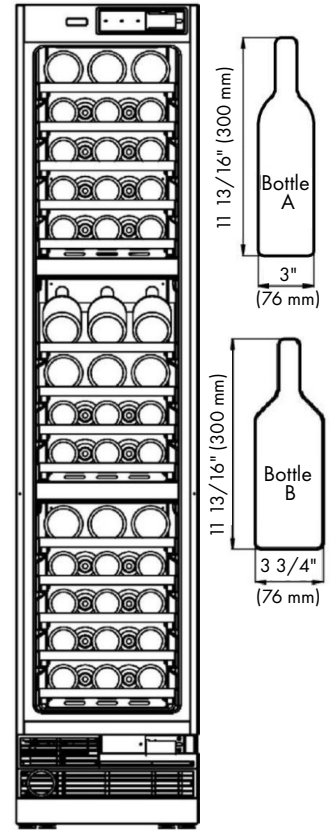

OPERATION

PRODUCT SPECIFICATIONS

Description of Product	Wine Cooler
Model	RBCWV-24 models
Voltage/Frequency	VAC 115/60Hz
Amperage	1.5A
Storage Capacity*	100 standard bottles or 94 Bordeaux-style bottles
Refrigerant	R600a
Temperature Range	41 °F – 68 °F (5 °C – 20 °C)
Dimensions	23 3/4" W x 23 5/16" D x 83 9/16" H 603 mm W x 592 mm D x 2123 mm H

*Storage capacity is based on standard wine bottles and 750 ml Bordeaux-style wine bottles.

Internal storage options

Load capacity	Bottle storage (Bottle A)	
Upper zone	1	7
	2	7
	3	7
	4	7
	5	7
Middle zone	1	9
	2	7
	3	7
	4	7
Lower zone	1	7
	2	7
	3	7
	4	7
	5	7
Total	100	

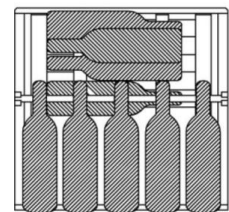
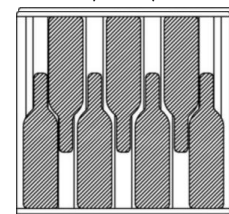
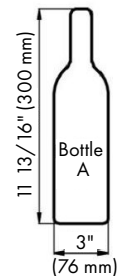
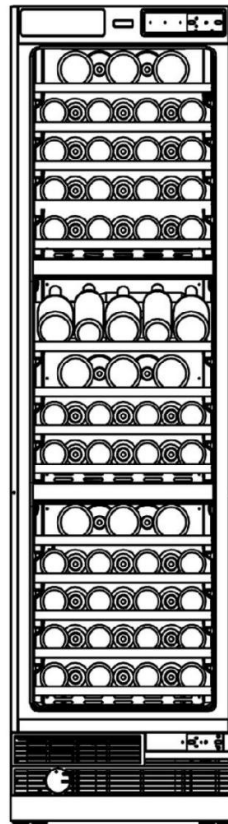

OPERATION

PRODUCT SPECIFICATIONS

Internal storage options

Load capacity		Bottle storage (Bottle A)	Bottle storage (Bottle B)
Upper zone	1	-	5
	2	7	-
	3	7	-
	4	7	-
	5	7	-
Middle zone	1	6	3
	2	-	5
	3	7	-
	4	7	-
Lower zone	1	-	5
	2	7	-
	3	7	-
	4	7	-
	5	7	-
Total		76	18

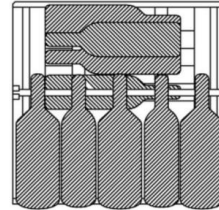
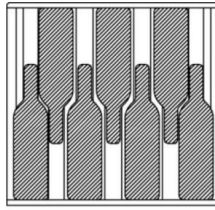
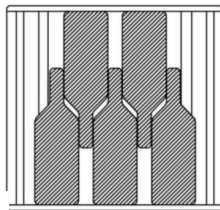
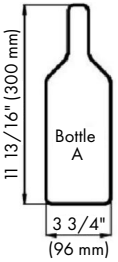
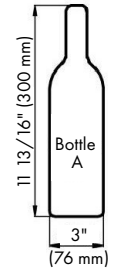
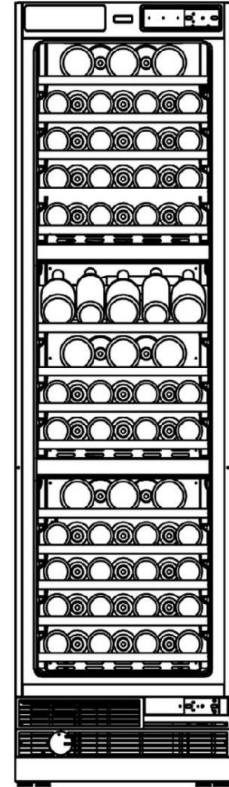

OPERATION

OPERATION - ALL MODELS

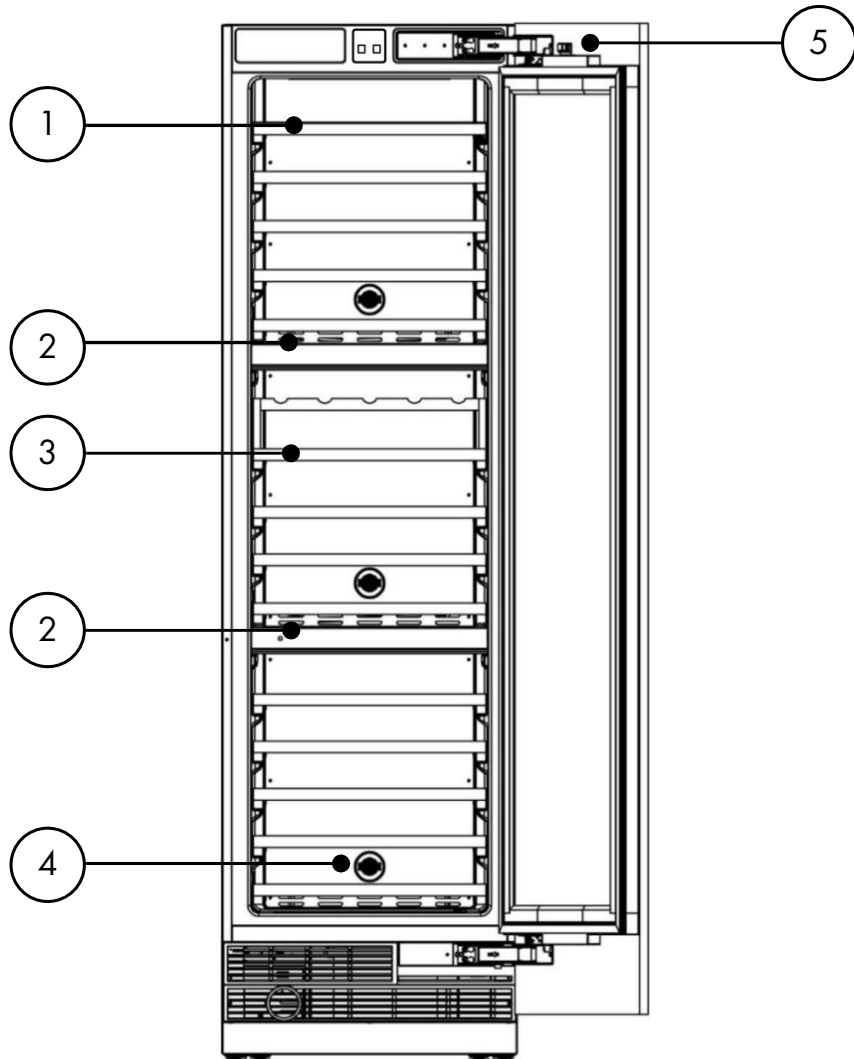

1. Standard Wine Rack
2. Zone Divider
3. Display Wine Rack
4. Carbon Filter
5. Door Switch

OPERATION

OPERATION

If the unit is unplugged, turned off, or loses power, you must wait 3 to 5 minutes before restarting the unit. If you attempt to restart before this time delay, the appliance may not start and will not keep the last set temperature.

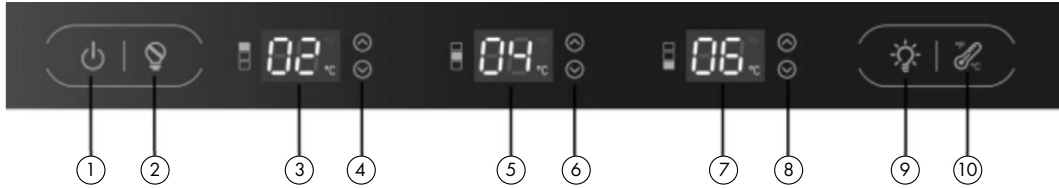

1. Power On/OFF
2. Sabbath Mode
3. Upper Zone Temp
4. Upper Zone Temp. Control
5. Middle Zone Temp
6. Middle Zone Temp. Control
7. Lower Zone Temp
8. Lower Zone Temp. Control
9. Light Button
10. Temp. Display Change

NOTE: If the control panel has moisture or liquid on its surface, it may be unresponsive. Wipe the moisture or liquid using a dry cloth, and then try again.









Power failure memory function: After powering on, the settings default to the previously set adjustments before power failure.

Temperature: 41 °F – 68 °F (5 °C – 20 °C)

OPERATION







OPERATION

NOTE: Whenever a key is pressed, the buzzer beeps.

- **Control Panel Lock** ( +  + ). The control panel is unlocked by default.
 - **To lock:** Press  + 
 - When the controls are locked, any input on the control panel will result in the display flashing for 3 seconds, indicating the locked status.
- **Power On/Off** (" for 3 seconds to power the unit on or off.
- **Light Button** (" once to change the LED lighting color from amber, to blue, to white, to off. **NOTE:** The light does not retain its previous setting.
- **Exhibition Mode:**
 - Press and hold "" for 5 seconds to enable the lighting whether the door is open or closed. Once entered, the display will show "ON" for 5 seconds and the display will stay on for 30 seconds after closing the door. The interior light stays on until this setting is disabled.
 - To disable this setting, press and hold the light button again. The display will show "OFF" for 5 seconds. After closing the door, the display will stay on for 30 seconds but the interior light turns off immediately.
- **Brightness Adjustment:** When the display shows the "ON" state (setting above), the key "" can be pressed up or down to adjust the lighting brightness. Adjust between 7 levels of brightness, L1-L7, with L7 being the brightest. Once set, the unit retains this brightness setting.

OPERATION

OPERATION

- **Door Opening and Closing Functionality:**
 - When the door is opened, the interior light turns on, and the display is active until the door is closed. The door alarms when the door is left open for 2 minutes. The fan stops when the door is left open for more than 5 minutes. When the open door alarm is active, the alarm can be canceled by pressing any button.
 - When the door is closed, the interior light is off (unless in Exhibition Mode), and the fan runs normally. The display will be off when the door is closed for 30 seconds.
- **Sabbath Mode:** Press and hold "" for 5 seconds to enter or exit Sabbath Mode. When enabled, the cooling system will run normally, and the lights, display, and all tones/alarms will be off. Sabbath Mode will automatically disable after 96 hours unless disabled manually.
- **Showroom Mode:** While the power is off, press and hold " + " for 5 seconds to enter the Showroom Mode. The compressor turns off, but all other functions are normal. The three temperature zones display "Sn". No keys can be pressed when the panel displays "Sn". Press "" to access functions such as light and temperature adjustment. Press and hold " + " again to exit Showroom Mode.
 - Power failure memory means that Showroom Mode won't quit if the cooler unexpectedly turns off. To exit Showroom Mode, use the method above or wait 72 hours.

OPERATION

DEFROSTING

The wine cooler is designed with an automatic defrost system. However, on colder settings, some frost may build up. Additionally, the more humid the ambient conditions, the more frost that may build up. Keep the door closed as much as possible and avoid opening the door unnecessarily to minimize frost build-up.

If frost is preventing the door from closing properly, you may need to power the unit off until the frost melts (possibly up to 24 hours). Use a soft absorbent towel to dry the unit.



WARNING

Do not puncture refrigerant tubing

NORMAL SOUNDS

Your new wine cooler may make sounds that are not familiar to you. Most of the sounds are normal. Hard surfaces like the floor or walls can make the sounds seem louder than they actually are. The following describes the kinds of sounds that might be new to you and what may be making them.

- Rattling noises may come from the flow of the refrigerant or the water line.
- Items stored on top of the wine cooler can also make noises.
- The high efficiency compressor may make a pulsating or high-pitched sound.
- Water running from the evaporator to the water bin may make a splashing sound.
- As each cycle ends, you may hear a gurgling sound due to the refrigerant flowing in your wine cooler.
- You may hear air being forced over the condenser by the condenser fan.

MAINTENANCE AND CLEANING

REMOVING THE WOODEN SHELVES

1. Pull the rack all the way out, then lift the front of the rack so that it is no longer resting on the peg toward the front.

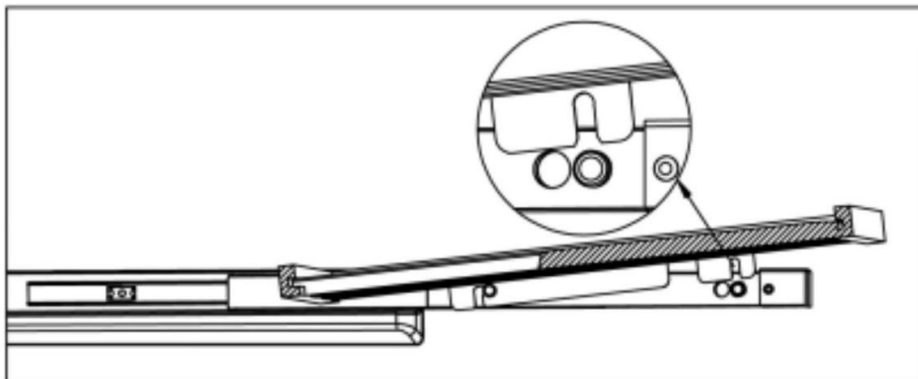

2. Continue pulling the rack forward so that it is no longer resting in the L-shaped slot toward the rear.

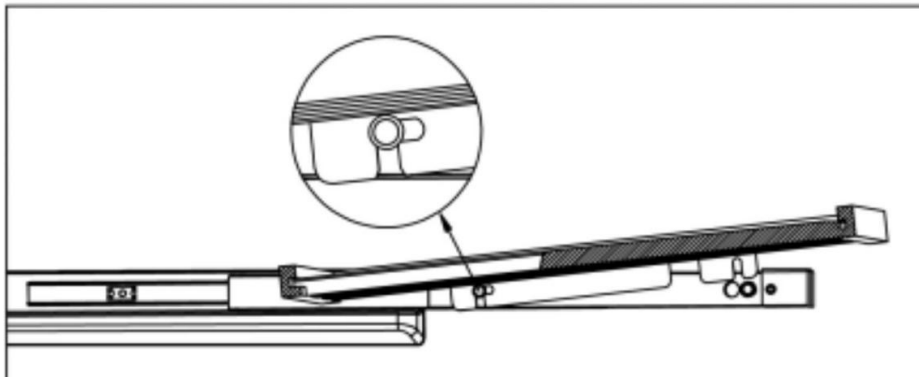

3. Lift the wine rack up to remove.

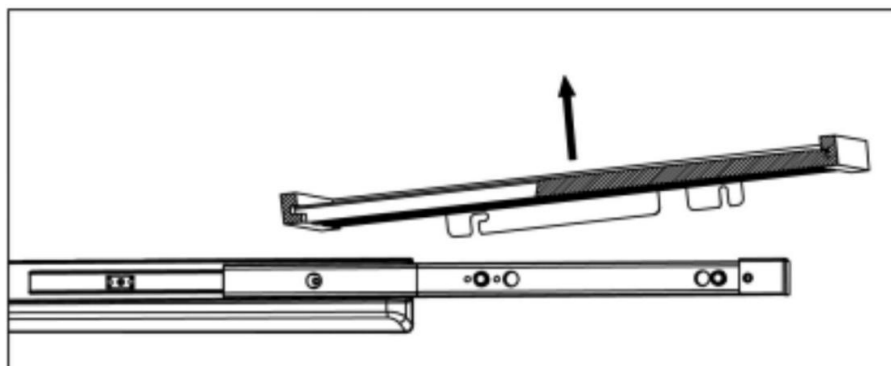

MAINTENANCE AND CLEANING

CARBON FILTER

A built-in carbon filter protects your wine by acting as a natural barrier against harmful odors. The carbon filter should be replaced every 3-6 months depending on the unit's exposure level to odor. If the unit is placed in a kitchen, regular replacement every 3 months is ideal.

Remove the carbon filter by turning counterclockwise to unlock from rear panel.

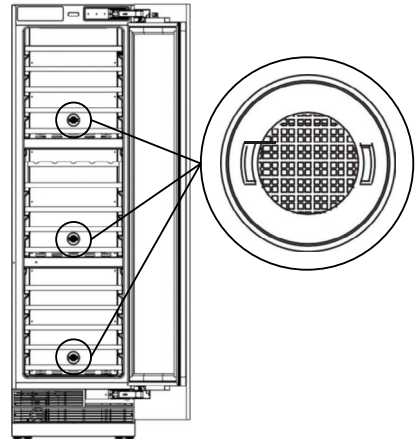

CLEANING THE UNIT

Periodic cleaning and proper maintenance will ensure efficiency, top performance, and long life.

Interior Cleaning

1. Disconnect power to the unit.
2. Open the door and remove the contents and shelves.
3. With a clean cloth, wipe down the interior of the unit.
4. Reinsert the shelves and wine.
5. Reconnect power to the unit.

Exterior Cleaning

The door and cabinet may be cleaned with a mild detergent and lukewarm water solution such as two (2) tablespoons of baking soda to one (1) quart of water. Do not use solvent based or abrasive cleaners. Use a soft sponge and rinse with clean water. Wipe with a soft clean towel to prevent water spotting. If the door panel is stainless steel, it can discolor when exposed to moisture. Clean stainless steel with a cloth dampened with a mild detergent and warm water solution. Never use an abrasive or caustic cleaning agent.

MAINTENANCE AND CLEANING

POWER FAILURE

Most power failures are corrected within a few hours and should not affect the temperature of your appliance if you minimize the number of times the door is opened. If the power is going to be off for a longer period of time, you need to take the proper steps to protect your contents.

MOVING YOUR WINE COOLER

- Remove all items.
- Securely tape down all loose items (shelves) inside your appliance.
- Turn the adjustable leg all the way up (counter-clockwise) to the base to avoid damage.
- Tape the door shut.
- Be sure the appliance stays secure in the upright position during transportation. Also protect outside of appliance with a blanket, or similar item.

ENERGY SAVING TIPS

- The appliance should be located in the coolest area of the room, away from heat producing appliances, and out of the direct sunlight.
- Ensure that the unit is adequately ventilated. Never cover air vents.
- Only open the door for as long as necessary.

TROUBLESHOOTING

- Please review this list for common troubleshooting tips before calling for service, as this may save you time and money.
- This list contains frequently encountered problems that are not results of faulty workmanship or material use.
- Your product may not have some of the features described here.



If a problem cannot be resolved after following the instructions in the manuals, please contact ZLINE customer service at 1-614-777-5004. Never attempt to repair or disassemble a faulty refrigerator sealed system as there are no user-serviceable parts. Always consult a professional.

PROBLEM	POSSIBLE CAUSE	POSSIBLE SOLUTION
The refrigerator is not operating.	It may not be plugged in properly.	Plug in the product properly.
	Loss of power to the outlet to which your refrigerator is connected.	Check the circuit breaker or fuse may have blown.
There is condensation in the refrigerator compartment	The door may have been opened/closed frequently.	Do not open/close the refrigerator door frequently.
	The environment may be too humid.	Do not install the refrigerator at locations with a very high level of humidity.
	Liquid may have been placed into the refrigerator in containers without covers.	Do not place liquid into the refrigerator in unsealed containers.
	The door of the refrigerator may have been left ajar.	Do not keep the door of your refrigerator open for a long time.

TROUBLESHOOTING

PROBLEM	POSSIBLE CAUSE	POSSIBLE SOLUTION
The compressor is not operating.	The internal protector of the compressor will open, protecting the compressor, and it will reset automatically.	The refrigerator will start running approximately after 6 minutes. Please call ZLINE at 1-614-777-5004 if the refrigerator does not start at the end of this period.
	The unit is in defrosting cycle.	This is normal for a refrigerator that performs full-automatic defrosting.
	Defrosting cycle is performed periodically.	This is normal for the unit to defrost periodically.
	The refrigerator may not be plugged in.	Make sure that the plug fits the socket.
	Temperature settings may be incorrect.	Select the correct temperature value.
	Possible power failure.	The refrigerator will start to operate normally when power restores.
The operation noise increases when the refrigerator is running.	Operating performance of the refrigerator may vary based on the ambient temperature changes.	This is normal and not a fault.

TROUBLESHOOTING

PROBLEM	POSSIBLE CAUSE	POSSIBLE SOLUTION
Vibration or noise.	The floor may not be stable or level.	If you notice that the refrigerator shakes when moved slightly, make sure that the floor is level and capable of carrying the refrigerator. Adjust feet as necessary.
	Objects placed on top of the refrigerator may cause noise.	Remove the objects on the refrigerator.
There are noises coming from the refrigerator like liquid spilling or spraying.	Liquid and gas flows occur normally in accordance with the operating principles of the refrigerator.	This is normal and not a fault.
A whistling noise is heard from the refrigerator.	There are fans that are used to cool the refrigerator.	This is normal and not a fault.
Condensation accumulates on the inner walls of refrigerator.	Hot and humid weather increases icing and condensation.	This is normal and not a fault.
	The door may have been opened frequently or left ajar for a long time.	Do not open the door frequently. Close the door, if open.
	The door may have been left ajar.	Close the door completely.

TROUBLESHOOTING

PROBLEM	POSSIBLE CAUSE	POSSIBLE SOLUTION
Humidity occurs on the outer surface of the refrigerator.	Air might be humid. This is quite normal in humid weathers.	Condensation will disappear as the humidity level decreases.
There is a bad odor inside the refrigerator.	No regular cleaning may have been performed.	Clean the inside of the refrigerator with a sponge and lukewarm water or carbonated water.
	Items may be expired or spoiled.	Take out expired or spoiled items from the refrigerator.
The door cannot be closed.	Bottles may be preventing the door from closing.	Re-locate the bottles obstructing the door.
	The refrigerator may be unstable on the floor.	Adjust the refrigerator feet as required to keep the refrigerator in balance.
	The floor may not be level or solid.	Make sure that the floor is level and capable of carrying the refrigerator.

TROUBLESHOOTING

ERROR CODES*

EXPLANATION	OPEN CIRCUIT CODE	SHORT CIRCUIT CODE
Upper Zone In-Cabinet Probes	E1	E2
Upper Zone Frosting Probe	E3	E4
Middle Zone In-Cabinet Probe	E5	E6
Middle Zone Frosting Probe	E7	E8
Lower Zone In-Cabinet Probes	E9	E10
Lower Zone Frosting Probe	E11	E12

*When there is an error code, the buzzer will emit three consecutive beeps and the error code will flash every 10 seconds. If you want to mute the alarm sound, press the On/Off key.

WARRANTY

COVERAGE

ZLINE Kitchen and Bath ("ZLINE") column refrigerators have a two year parts and service warranty and a five year parts warranty on the unit's sealed cooling system.

ZLINE warranty periods begin from the original date of product delivery and solely cover the original purchaser of the product, delivered new and in its original carton. The limited warranty covers all parts and labor for necessary repairs if any part of the product, or the product itself, proves to be defective in materials or workmanship.

The product must be deemed serviceable via troubleshooting with the ZLINE Customer Experience team. All service on ZLINE products under warranty must be performed by ZLINE-approved and ZLINE-certified service providers unless otherwise specified by ZLINE. Service will be provided during normal business hours.

Products must be unobstructed and accessible to the service provider at the time of service. ZLINE's liability is limited to the original purchase price of the product. Additional injuries, losses, damages, or other inconveniences caused by product malfunction or defects in materials are not covered under the terms of this warranty.

TERMS

ZLINE warranties apply only to the original purchaser of a ZLINE product installed for normal residential use. This is defined as a single-family, residential dwelling in a non-commercial setting. Any warranty claim stemming from installation, operation, or any other use within a commercial setting is not covered under this limited warranty. Commercial settings include, but are not limited to: schools, churches, hotels, restaurants, vacation rentals such as Airbnb, daycare centers, private clubs, fire stations, common areas in multi-family dwellings, nursing homes, food service locations, and institutional food service locations such as hospitals or correctional facilities.

This warranty is non-transferable and will not under any circumstance be extended based on the date of installation — the warranty period takes effect from the date of delivery and only covers the original purchaser. The warranty applies only to products installed in the contiguous United States and the District of Columbia.

WARRANTY

Failure to secure certified warranty service per these terms will result in a forfeiture of the remaining warranty. Out-of-pocket payments will not be reimbursed unless prior approval is received from ZLINE and/or ZLINE-certified service contract partners. Unapproved out-of-pocket payments for service will not be reimbursed. All warranty procedures must be followed to maintain warranty coverage.

If a product qualifies within the service window provided under these warranty terms, and ZLINE is unable to repair the product or a defective part of the product after a reasonable number of attempts, ZLINE reserves the right to offer to replace the defective part or the product or provide the original purchaser a full refund of the purchase price of the product (not including installation, removal, or other charges that were not included in the original purchase price).

The original purchaser of the product must provide the original proof of purchase, including the purchase date, when filing a claim to obtain replacement parts, service, or refunds. Additionally, the original purchaser of the product must provide the serial number of the product when filing a claim to obtain replacement parts, service, or refunds.

This warranty shall not apply to any ZLINE product in which the original factory serial number has been removed, altered, or cannot be readily determined for any reason. Further, ZLINE is not responsible for damage resulting from, but not limited to: shipment, delivery, or improper installation; negligence or improper maintenance, misuse, or abuse of the product; unauthorized alteration, modification, or tampering with the product; accident, fire, floods, pest infestations, pandemics, natural disasters, or any other unpreventable or unexplained acts of nature, commonly referred to as "acts of God"; flare-up fires or damages caused by improper electric supply, electrical line current, voltage, or power surges; and service to correct installation not in accordance with the instructions contained in ZLINE's product manuals and/or with local government codes.

In the event service is dispatched, and it is discovered that the reported issue is not covered under warranty based on the disclaimers above, the customer will be responsible for all service fees. Failure to pay these fees will result in the forfeiture of remaining warranty coverage.

WARRANTY

Information contained within ZLINE's installation and user manuals, in addition to product information included on ZLINE's website and all related digital listings, do not cover every possible condition and situation that may occur during the installation or operation of ZLINE products.

ZLINE reserves the right to make changes at any time to its products when considered safe, necessary, and useful. Always check the ZLINE website for the most up-to-date version of its product manuals: www.zlinekitchen.com/pages/manuals.

Do not install or operate any ZLINE product if it has missing or broken parts or if it arrives damaged due to shipping. If ZLINE products arrive damaged, contact ZLINE Customer Experience at 1-614-777-5004 for help. Failure to report a damaged appliance prior to installation or operation may void the warranty.

ZLINE disclaims responsibility for damage or injury caused by improper installation or use of any of its products. ZLINE is under no obligation, by law or otherwise, to provide concessions, including repairs, prorates, rebates, discounts, or replacements, once the warranty has expired.

SERIAL NUMBER LOCATION

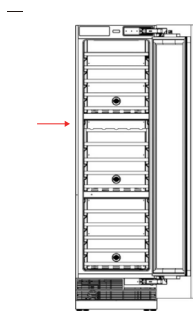

The rating tag shows the model and serial number of your refrigerator. The product label and rating tag are located on the left-hand side of the cabinet. The tag is visible when the refrigerator door is open. Do not remove permanently affixed labels, warnings, or plates from the product. This will void the warranty.

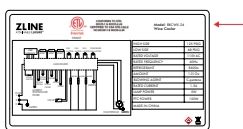

WARRANTY



SERVICE

For warranty service, please contact our Customer Service team at 1-614-777-5004 or visit www.zlinekitchen.com/contact to utilize our online Customer Experience Portal.



Scan the QR code to view the most up-to-date version of our user manual and installation manual.



Need to purchase a part or accessory for your ZLINE product?
Visit www.zlineparts.com, ZLINE's official parts distribution partner.

1.0.0

1-614-777-5004

www.zlinekitchen.com

contact@zlinekitchen.com

ZLINE
ATTAINABLE LUXURY®

