

# Cordless Stick Vacuum Cleaner

User Manual



VRT 82821 BV  
VRT 82821 DV

**EN**

01M-8813433200-4418-01  
01M-8813453200-4418-01



**beko**

# CONTENTS

<b>1 Important safety and environmental instructions</b>	<b>8</b>
1.1 General safety .....	8
<b>2 Part assembling</b>	<b>11</b>
Elbow and flexible hose .....	11
<b>3 Use</b>	<b>11</b>
3.1 Charging Indicator .....	11
<b>4 Cleaning and maintenance</b>	<b>12</b>
4.1 Cleaning and care.....	12
4.2 Hepa filter .....	12
<b>5 Information</b>	<b>13</b>
5.1 Compliance with the WEEE Directive and disposal of the waste product .....	13
5.2 Compliance with RoHS Directive.....	13
5.3 Package information .....	13
5.4 Information on waste batteries.....	13
5.5 Storage.....	13
5.6 Handling and transportation .....	13

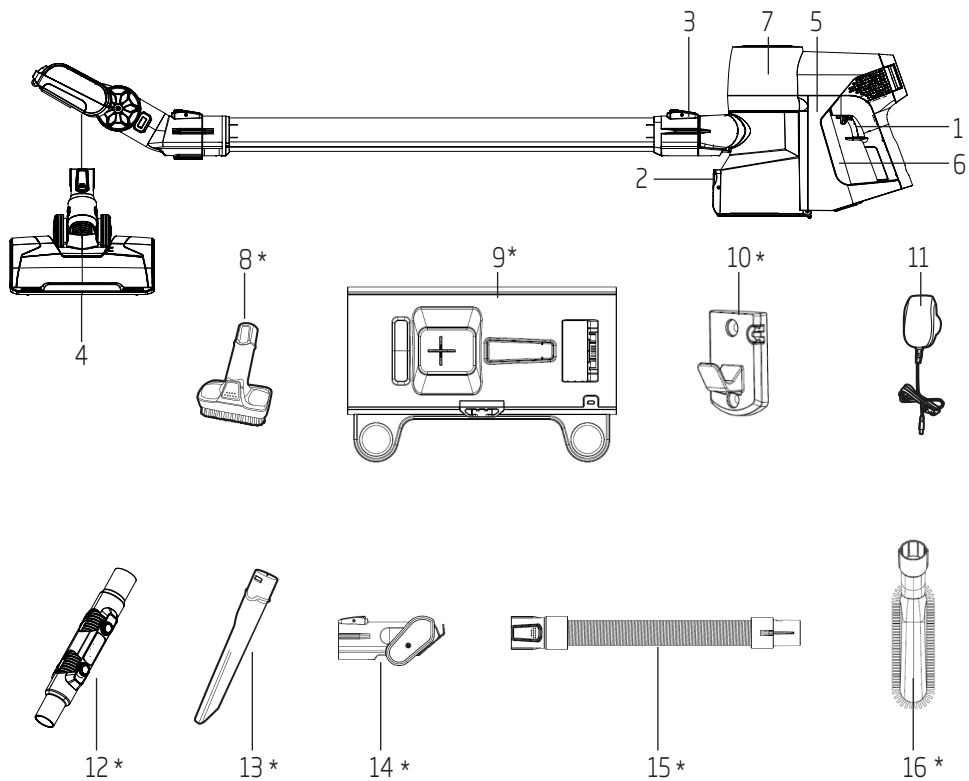



		
EN	OPERATION	CLEANING AND CARE

\* Not ALL accessories available on ALL models.

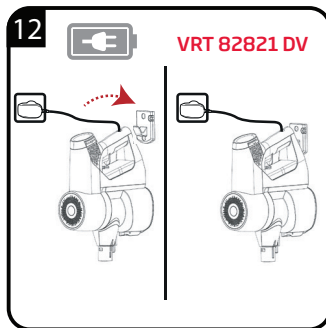
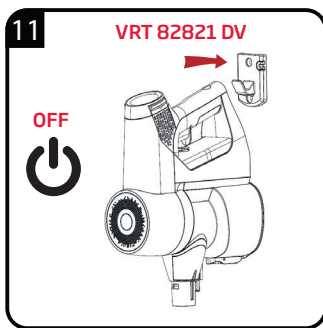
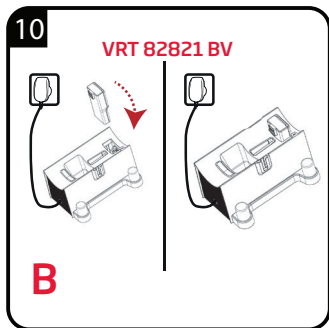
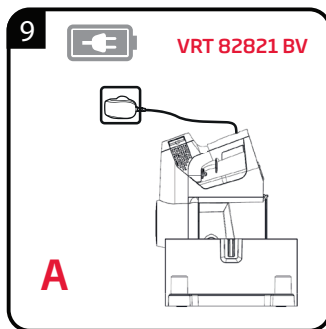
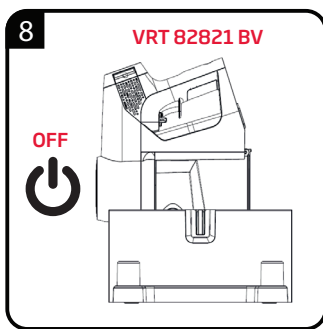
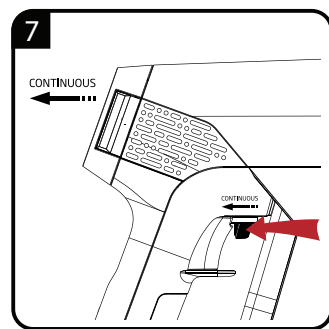
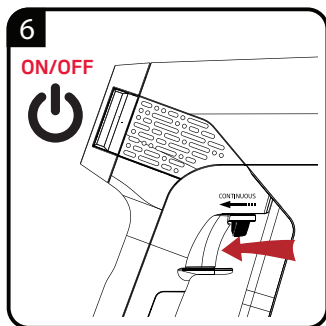
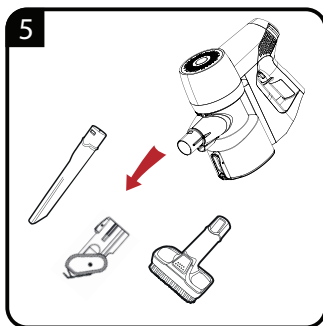
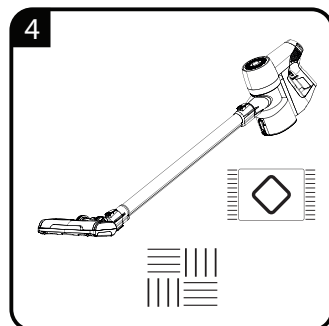
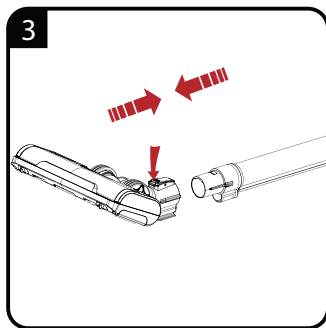
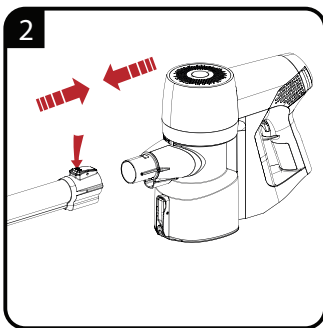
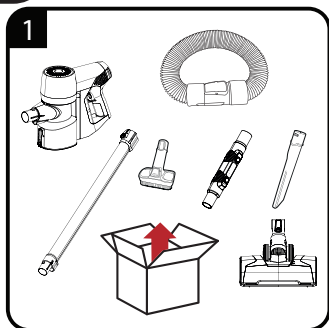

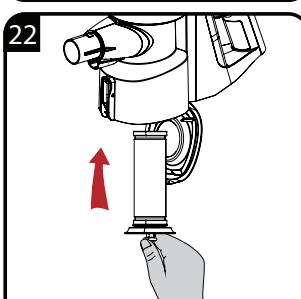
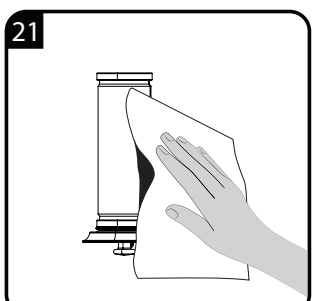
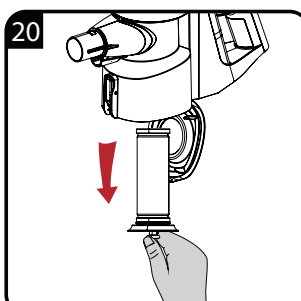
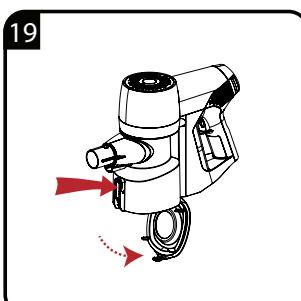
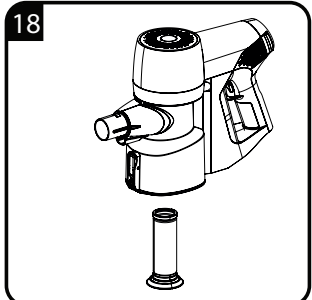
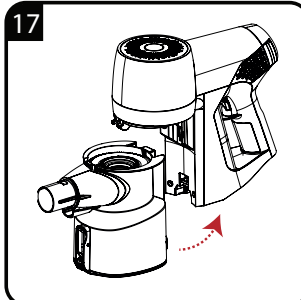
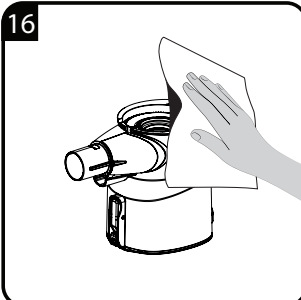
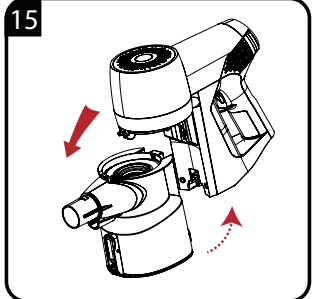
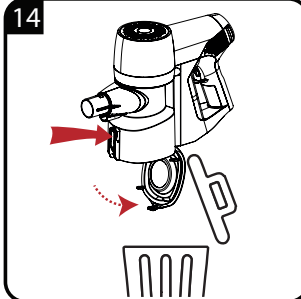
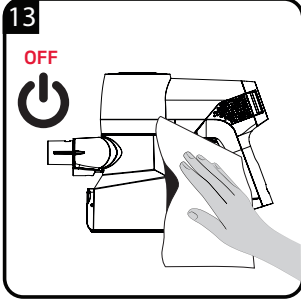

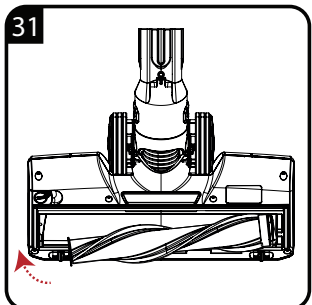
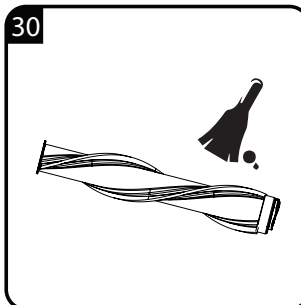
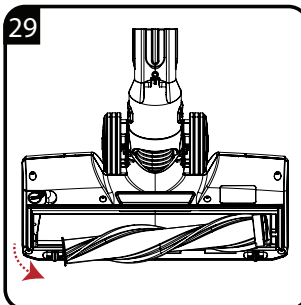
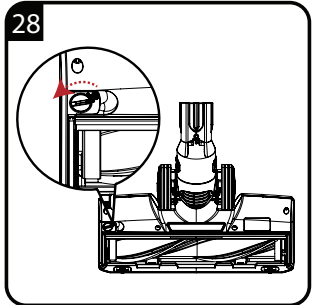
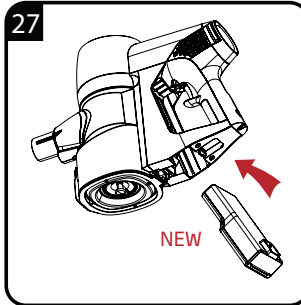
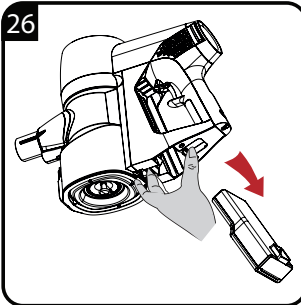
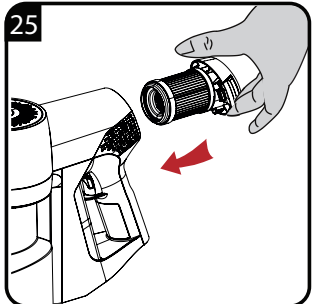
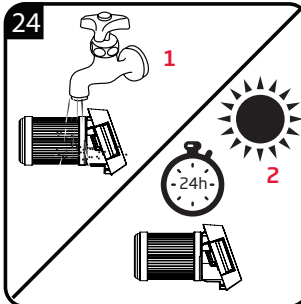
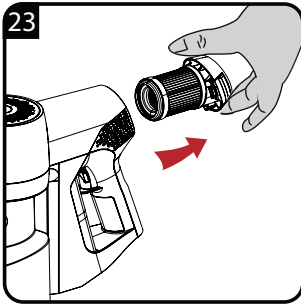

# Please read this manual first!

Dear Customer,

Thank you for selecting a Beko product. We hope that you get the best results from your appliance which has been manufactured with high quality and state-of-the-art technology. For this reason, please read this user manual and all other provided documents carefully before using the appliance and keep it as a reference for future use. If you hand over the appliance to someone else, give the user manual as well.

1. Switch button
2. Dust cup release button
3. Metal tube release button
4. Electrical turbo brush
5. Machine body
6. Battery pack
7. Dust cup
8. Two-in-one brush
9. Charging dock (VRT 82821 BV)
10. Wall hook (VRT 82821 DV)
11. Power supply plug
12. Elbow (VRT82821BV)
13. Crevice
14. Mini turbo brush (VRT82821BV)
15. Flexible hose (VRT82821BV)
16. Dust brush (VRT82821BV)

## Technical data

**Rated input power :**  
180W (VRT82821BV)  
100W (VRT82821DV)

Follow the instructions by paying attention to all the information and warnings in the user manual.

## Meanings of the symbols

Following symbols are used in various sections of this manual:



Important information and useful advices regarding the usage.



**WARNING:** Warnings for dangerous situations concerning the safety of life and property.



Protection class for electric shock.

**Input :**  
100 - 240 V ~ 50-60Hz 0.8 A (max)

**Output :** 26.0V  0.6A

**Charging time :** 3-4 hours

**Running time max. power**  
VRT82821DV : 22 min.  
VRT82821BV : 12 min.

**Running time min. power to up to:**  
40 min.

Technical and design modifications reserved.

The values which are declared in the markings affixed on your appliance or the other printed documents supplied with it represent the values which were obtained in the laboratories pursuant to the pertinent standards. These values may vary according to the usage of the appliance and ambient conditions.



This appliance has been produced in environmentally-friendly, state-of-the-art facilities.



This product does not contain PCB'S.

# 1 Important safety and environmental instructions

This section contains safety instructions that will help protect from risk of personal injury or property damage.

Failure to follow these instructions invalidates the granted warranty.

## 1.1 General safety

- This appliance complies with international safety standards.
- This appliance can be used by children aged from 8 years and above and persons with reduced physical, sensory or mental capabilities or lack of experience and knowledge if they have been given supervision or instruction concerning use of the appliance in a safe way and understand the hazards involved. Children shall not play with the appliance. Cleaning and user maintenance shall not be made by children without supervision.
- If the adapter or the appliance itself is damaged, do not use it. Contact an authorised service.
- Your mains power supply should comply with the information supplied on the rating plate of the appliance.
- Do not use the appliance with an extension cable.
- Prevent damage to the power cable by not squeezing, bending, or rubbing it on sharp edges.
- Do not touch the appliance or its plug when it is plugged if your hands are damp or wet.
- Do not pull the power cable when unplugging the appliance.
- Do not vacuum flammable materials and when vacuuming cigarette ash, make sure that it has cooled down.
- Do not vacuum water or other liquids.
- Protect the appliance from rain, humidity and heat sources.
- Never use the appliance in or near places where combustible or inflammable ambience or places are present.
- Unplug the appliance before cleaning and maintenance.
- Do not immerse the appliance or its power cable in water for cleaning.
- Do not attempt to dismantle the appliance.

# 1 Important safety and environmental instructions

- Use the original parts or parts recommended by the manufacturer only.
- Do not clean the particles such as cement, plaster and compressed paper in order to prevent the filter from being clogged and the motor being damaged.
- Use the appliance only with the adapter supplied with.
- Do not use the appliance without filters; otherwise it can get damaged.
- If you keep the packaging materials, store them out of the reach of children.
- This appliance is not intended for use by persons (including children) with reduced physical, sensory or mental capabilities, or lack of experience and knowledge, unless they have been given supervision or instruction concerning use of the appliance by a person responsible for their safety
- Children should be supervised to ensure that they do not play with the appliance
- The appliance is only to be used with the power supply unit provided with the appliance.
- The adapter must be removed from the socket-outlet and the battery pack must be removed from the appliance before cleaning or maintaining the appliance
- If the adapter is damaged, it must be replaced by the manufacturer or its agent or similarly qualified person in order to avoid hazard.
- Keep fingers, hair and loose clothing from moving parts and openings whilst using the vacuum cleaner
- The battery must be removed from the appliance before it is scrapped;
- The appliance must be disconnected from the supply mains when removing the battery;
- Please dispose of used batteries according to local laws and regulations.
- This appliance contains batteries that are only replaceable by skilled persons.
- **WARNING:** For the purposes of recharging the battery, only use the detachable supply unit DK20C-260060H-B provided with this appliance.
- Please remove and insert the batteries according to UM.

# 1 Important safety and environmental instructions

- Rechargeable batteries are to be removed from the appliance before being charged;
- Different types of batteries or new and used batteries are not to be mixed.
- Batteries are to be inserted with the correct polarity.
- Exhausted batteries are to be removed from the appliance and safely disposed of.
- If the appliance is to be stored unused for a long period, the batteries should be removed.
- The supply terminals are not to be short-circuited.
- Only use with ZB1852 battery.

## 2 Part assembling

### Elbow and flexible hose

The elbow and flexible hose are extension tools, one end is inserted into the suction port, the other end is connected with the accessories, which can clean corners or narrow spaces

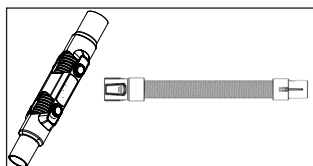

## 3 Use

### 3.1 Charging Indicator

Working	Charging	Fully charged	Lower power
Persistent white light	Blinking white light	Persistent white light 2 minutes and then going out.	Blinking red light



- When you receive this product, please use the charger provided by our company to recharge the battery for 3 hours (no need to charge it full) and the charging frequency should be every 3 months.
- Do not place the battery on the charging base for a very long time. If it is still charging beyond the normal charging time, stop it immediately. Otherwise, the battery may cause heating, deformation or burning hazard.
- When the battery is not in use for a long time or it is over-discharged, you may find the working time is reduced at the first few times. We recommend you fully charge the battery (usually 4.5 hours) and discharge it. Repeat this action two times.

## 4 Cleaning and maintenance

### 4.1 Cleaning and care

Switch off and unplug the appliance ,before cleaning it.



**WARNING:** Never use gasoline, solvent, abrasive cleaning agents, metal objects or hard brushes to clean the appliance.

### 4.2 Hepa filter

- In order to ensure the performance of the product, we recommend you clean regularly, and replace one after 3-6 months. (Depending on usage)



**WARNING:** Long-term no use, please keep the battery intact, stored in a cool dry place, and let the battery in the semi-state of charge. Not full or empty. Please enclose the battery with non-conductive material to avoid the metal touching the battery directly, causing the battery to be damaged.

## 5 Information

### 5.1 Compliance with the WEEE Directive and disposal of the waste product



This product complies with EU WEEE Directive (2012/19/EU). This product bears a classification symbol for waste electrical and electronic equipment (WEEE). This product has been manufactured with high quality parts and materials which can be reused and are suitable for recycling. Do not dispose of the waste product with normal domestic and other wastes at the end of its service life. Take it to the collection center for the recycling of electrical and electronic equipment. Please consult your local authorities to learn about these collection centers..

### 5.2 Compliance with RoHS Directive

The product you have purchased complies with EU RoHS Directive (2011/65/EU). It does not contain harmful and prohibited materials specified in the Directive.

### 5.3 Package information



Packaging materials of the product are manufactured from recyclable materials in accordance with our National Environment Regulations. Do not dispose of the packaging materials together with the domestic or other wastes. Take them to the packaging material collection points designated by the local authorities.

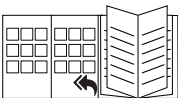

Please see the cover page of the user manual for initial use, general use and cleaning sections.

### 5.4 Information on waste batteries



This symbol on rechargeable batteries/batteries or on the packaging indicates that the rechargeable battery/battery may not be disposed of with regular household rubbish. For certain rechargeable batteries/batteries, this symbol may be supplemented by a chemical symbol. Symbols for mercury (Hg) or lead (Pb) are provided if the rechargeable batteries/batteries

contain more than 0,0005 % mercury or more than 0,004 % lead.



Rechargeable batteries/batteries, including those which do not contain heavy metal, may not be disposed of with household waste. Always dispose of used batteries in accordance with local environmental regulations. Make enquiries about the applicable disposal regulations where you live.

### 5.5 Storage

- If you do not intend to use the appliance for a long time, store it carefully.
- Pull the appliance's plug out.
- Keep the appliance out of the reach of children.

### 5.6 Handling and transportation

- During handling and transportation, carry the appliance in its original packaging. The packaging of the appliance protects it against physical damages.
- Do not place heavy loads on the appliance or on the packaging. The appliance may get damaged.
- Dropping the appliance may render it non-operational or cause permanent damage.



## Product Guarantee

### 12 months breakdown and repair guarantee

Guarantor: **Beko plc, 1 Greenhill Crescent, Watford, Hertfordshire. WD18 8UF**

The guarantee does not in any way diminish your statutory or legal rights.

Your **appliance** has the benefit of our manufacturer's guarantee which covers the product for 12 months from the date of original purchase.

This gives you reassurance that if within that time, your **appliance** is proven to be defective because of either workmanship or materials, we will at our discretion either repair or replace your **appliance**.

The **appliance** must be correctly installed, located and operated in accordance with the instructions contained in the user manual. The guarantor disclaims any liability for accidental or consequential damage.

#### The Guarantee is subject to the following conditions:

- Documentary proof of the original purchase date is provided.
- The appliance has been installed and operated correctly and in accordance with our operating and maintenance instructions.
- The appliance is used only on the electricity supply on the rating plate.
- The appliance has only been used for normal domestic purposes.
- The appliance has not been altered, serviced, dismantled or otherwise interfered with by any person.
- The appliance is used in the United Kingdom or Republic of Ireland.
- Any parts removed during repair work or any product that has been replaced becomes our property.
- The guarantee is not transferrable if the product is resold.

#### The Guarantee does not cover:

- Transit, installation or delivery damage.
- Accidental damage.
- Misuse or abuse.
- Replacement of any consumable item or accessories. These include but are not limited to: plugs, cables, light bulbs, knobs, filters and flaps.
- Repairs or replacements required as a result of unauthorised repairs or inexperienced installation that fails to meet the requirements contained in the user guide or instruction book.
- Repairs to products used in commercial or non-residential household premises.

#### **How to obtain after sales service, help or general advice**

**Please keep your purchase receipt or other proof of purchase in a safe place as you will need to show us this document if your product requires attention within the guarantee period.**

Please also record your product details below, which will allow you to access our services more quickly and help us identify your product. The model number is printed on the front of the user guide and the serial and model number is shown on your products rating plate.

Model number	Serial number	Purchased from	Date of purchase

Please call our UK based Customer Service department if you need help or advice from us:

United Kingdom and Northern Ireland: **0845 600 4911 / 0345 600 4911**

Republic of Ireland: **01 862 3411**

You can also contact us through our website: **[www.beko.co.uk](http://www.beko.co.uk)**

