



# Technical Product Guide

## WIRED TETHER CONTROLLER

Part Numbers:  
MC20700140 - XK-19  
MC207059 - XK-41



# Table of Contents

- Product Overview .....2-3
- Reference Table ..... 4
- Features and Benefits .....4-5
- Dimensional Specifications..... 6
- System Wiring Diagram..... 6
- Installation ..... 7
- Limited Warranty Statement .....8-9

# PRODUCT OVERVIEW

## SUPERIOR DESIGNS PROVIDE EASY SOLUTIONS TO COMPLEX PROBLEMS

GREE Ductless Multi Zone systems provide quiet comfort and energy efficient heating and cooling in up to five different rooms - *without ductwork*. For most residential and light commercial applications, this is the ideal solution to balance comfort, efficiency and ease of installation. This Inverter-driven system offers Seasonal Energy Efficiency Ratings (SEER) up to 16. With individual room control and variable speed compressor operation, comfort is boosted throughout your home or office, while utility bills are held in check.



*Gree's exclusive G-10 Inverter technology powers the twin rotary compressor inside the Multi Zone outdoor compressor section. The G-10 Inverter constantly adjusts the compressor speed to maintain a comfortable room temperature. This saves energy, reduces outdoor noise and maintains a steady room temperature by eliminating the harsh starts and stops of conventional systems.*

When laying out a new project, you'll appreciate the flexibility of Gree's Multi Zone Systems. A single outdoor unit can simultaneously power up to five indoor units while eliminating expensive ductwork. Without those ducts, your installation is simpler, faster and more cost-effective. And the flexibility doesn't stop there, as you can also mix and match your choice of Wall Mount, Ceiling Cassette, Concealed Duct, Universal Floor/Ceiling and Mini Floor Console indoor units to create a unique heating and cooling system to perfectly fit any project.

### No pipe sweating

No sweating is needed for the pipe connection between the indoor and outdoor units. All piping connections are flared to simplify and ease the piping installation.

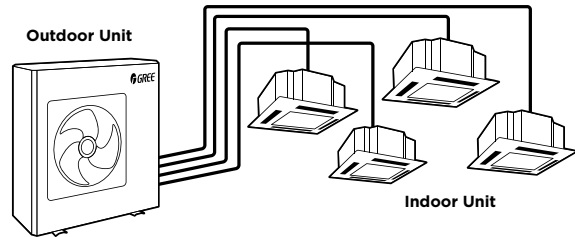

### Simple Wiring

No special or hard-to-find communication wire is needed between the indoor and outdoor units. The system uses common 14-4 AWG stranded copper THHN 600V wire. The system's communication is ready as soon as the electrical wiring between the indoor and outdoor units is complete.

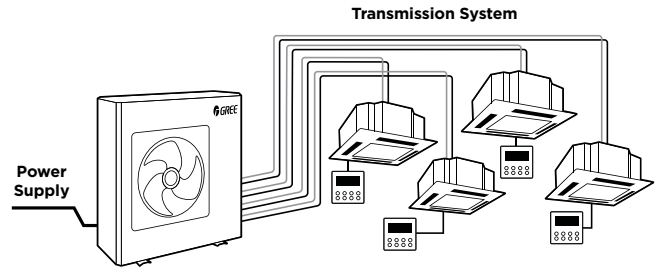

### High Lift Design

Gree's High Lift design allows for extended piping length, up to 262 feet total, as well as 50 feet of vertical lift from the condensing units. This allows for greater flexibility in the layout of the system.

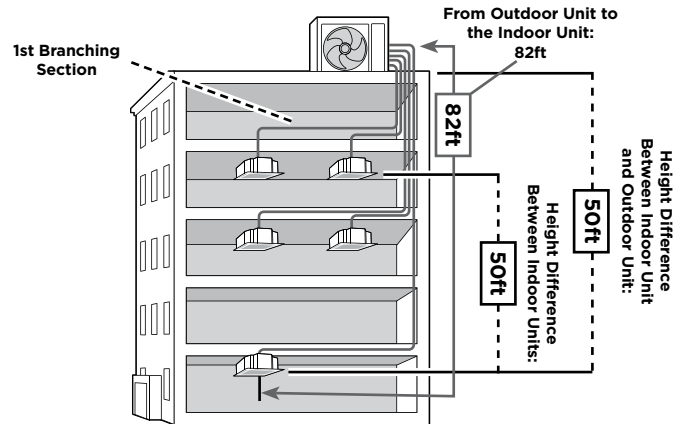

**Allows up to 262 feet of pipe length**

### Energy Saving

Multi Zone systems allow each room to be individually controlled. Only those rooms requiring air conditioning (or heating) are cooled (or heated), and all of it is accomplished without ductwork. In addition, Gree's G-10 inverter technology reduces energy waste, maximizes efficiency and achieves up to 16 SEER.



# PRODUCT OVERVIEW

## Self-Diagnostics System

Each indoor and outdoor unit continuously runs a series of multi-point diagnostic tests on the system, to automatically scan for unacceptable operating conditions or malfunctions. If such conditions occur, the system takes corrective action or stops. The fault code will be shown on the indoor, outdoor and wired controller displays. Problems and system status are displayed with comprehensive diagnostic codes to simplify system troubleshooting and shorten repair times.

## Flexible Design

Gree's Multi Zone systems have many advantages for both the property owner and the installer. Up to five indoor units, powered by a single outdoor unit, results in flexible zoning solutions for almost any application. Various styles of indoor units may be mixed and matched in any combination to create a unique, multiple zone heating and cooling system. Choose from Wall Mount, Ceiling Cassette, Slim Duct, Universal Floor/Ceiling and Mini Floor Console indoor units. All are lightweight and compact enough to be installed on the wall or in any ceiling space.

## Intelligent Control

Gree's Multi Zone components use state-of-the-art intelligent controls to generate the ultimate in room comfort. G-10 Inverter technology delivers the exact level of required capacity (from 10% to 100%) to maintain room temperature and humidity in the comfort range. The optimized PID controls maintain the room temperature within less than  $\pm 1.0^{\circ}\text{F}$  of the room setpoint temperature. The result is a virtually constant room temperature without the typical fluctuations that occur with a conventional fixed speed ON/OFF system.

## Ductless Saves Money

Realize energy savings by eliminating heat loss from inefficient and leaky ductwork. The average ducted air distribution system could reduce overall system efficiency by up to 30 percent. Eliminating ductwork allows you to downsize equipment while upsizing performance.

Diagnostic Code	Malfunction
E1	Compressor High Pressure Protection
E2	Indoor Coil Anti-Freeze Protection
E3	Low Pressure Protection
E4	High Discharge Temperature Protection
E5	Compressor High Temperature Protection
E6	Indoor/Outdoor Communication Failure
E7	Heating & Cooling Modes Conflict
E9	Condensate Water Too High
F4	Outdoor Coil Sensor Failure

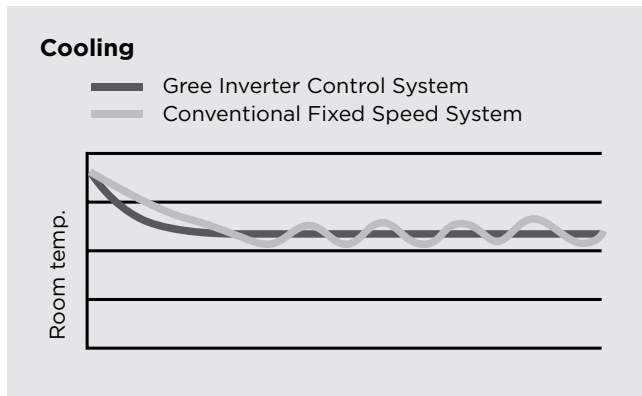
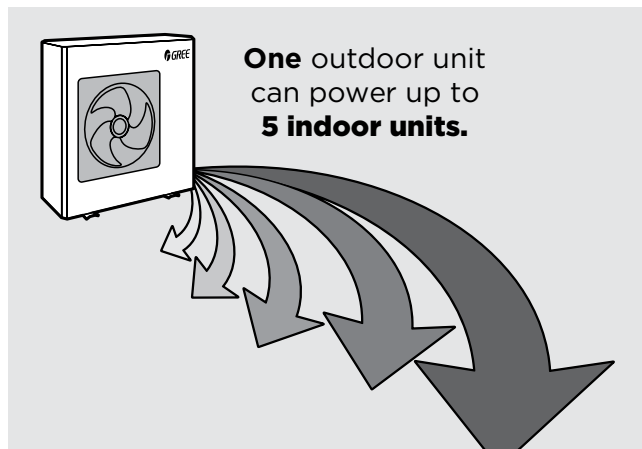

# Wired Tether Controller



## REFERENCE TABLE

INDOOR UNIT	TETHER CONTROLLER	
	TYPE	PART NUMBER
NEO WALL MOUNT	XK-41	MC207059
CEILING CASSETTE	XK-19	MC20700140
SLIM CONCEALED DUCT	XK-19	MC20700140
UNIVERSAL FLOOR CEILING	XK-19	MC20700140
MINI-FLOOR CONSOLE	XK-19	MC20700140

## FEATURES AND BENEFITS

### Attractive Appearance

The XK series features a sleek, unobtrusive design that fits seamlessly into any décor.

### Easy To Install

The XK series Wired Tether Controllers have been designed for fast and easy installation to save you time and money. Each XK wired controller comes with keyed connectors and 26 feet of cable. Its flexible design allows it to be mounted either flush to the wall or using an electrical box.

### Command Center

Enjoy the convenience of a fully functional command center with a large LCD display to set up and operate your duct free system. The XK series allows you fast and easy access to a large number of system features and functions:

*Note: Some indoor units may not support specific system features or functions. Always refer to the indoor unit Owner's Manual.*

#### On/Off

The XK series allows you to start and stop your system. The system will always start up in the last operating mode with the last room setpoint.

#### Operating Mode

The system allows users to effortlessly select an operating mode (Cooling, Heating, Dry, Fan Only or Auto mode) with a single key stroke.

# FEATURES AND BENEFITS

---

## Command Center (cont.)

### Fan Speed

The system fan speed (High, Medium, Low or Auto) can be adjusted for peak room comfort and quietness.

### Room Setpoint

The XK series makes dialing in the correct room setpoint temperature a breeze. Most indoor units allow a room setpoint from 61° F to 86° F (16° to 30° C).

### Timer Mode

When needed, the XK series allows you the ability to program a time period (one-half to 24 hours) to which your system will automatically turn ON or OFF.

### Sleep Mode

The XK series will automatically adjust room temperature during your sleep time. This slight change in temperature will not affect your comfort level due to the natural effects that sleeping has on the body, but it will save on energy consumption and will lower electric bills.

### Turbo Mode

Whether you need to heat up or cool down a room quickly, Turbo Mode will force your system to run at higher speeds to reach the desired room temperature faster.

### X-Fan Mode

The X-Fan function can be activated from the XK series to remove moisture buildup when the system is turned OFF. This helps prevent mold and mildew growth on your indoor coil and fan.

### Privacy Lock

The XK series has a Privacy Lock that can be set to prevent unauthorized access to the unit controls and prevents tampering with system settings.

### Power Failure Recovery

Power interruptions are no problem for the XK series wired controller. All user selections and system parameters are stored in non-volatile memory. When power is returned, the system will automatically return to the last operating mode.

### Swing Louver Control

The XK series provides control over the motorized discharge air louver to optimize air distribution throughout the room.

### Fahrenheit or Celsius Display

Whether you are more comfortable reading temperatures in Fahrenheit or Celsius, the XK series can quickly be set up to display either one.

### Diagnostic Center

The system has an on-board computer that continuously scans for unacceptable operating conditions or malfunctions. If such conditions occur, the system takes corrective action or stops. The fault or status codes will be shown on XK series wired tether controller display to facilitate easy troubleshooting and repair.

# Wired Tether Controller

## DIMENSIONAL SPECIFICATIONS

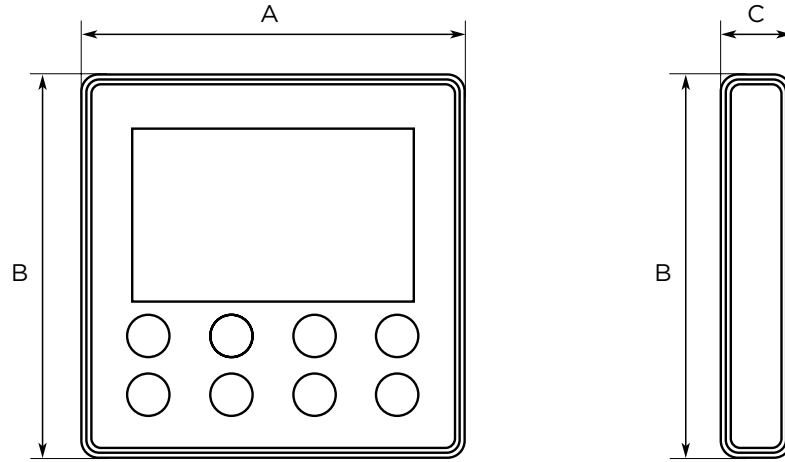

TYPE	PART NUMBER	A in (mm)	B in (mm)	C in (mm)
XK-41	MC207059	3.625 (92)	3.625 (92)	1.375 (35)
XK-19	MC20700140	3.625 (92)	3.625 (92)	1.375 (35)

## SYSTEM WIRING DIAGRAM

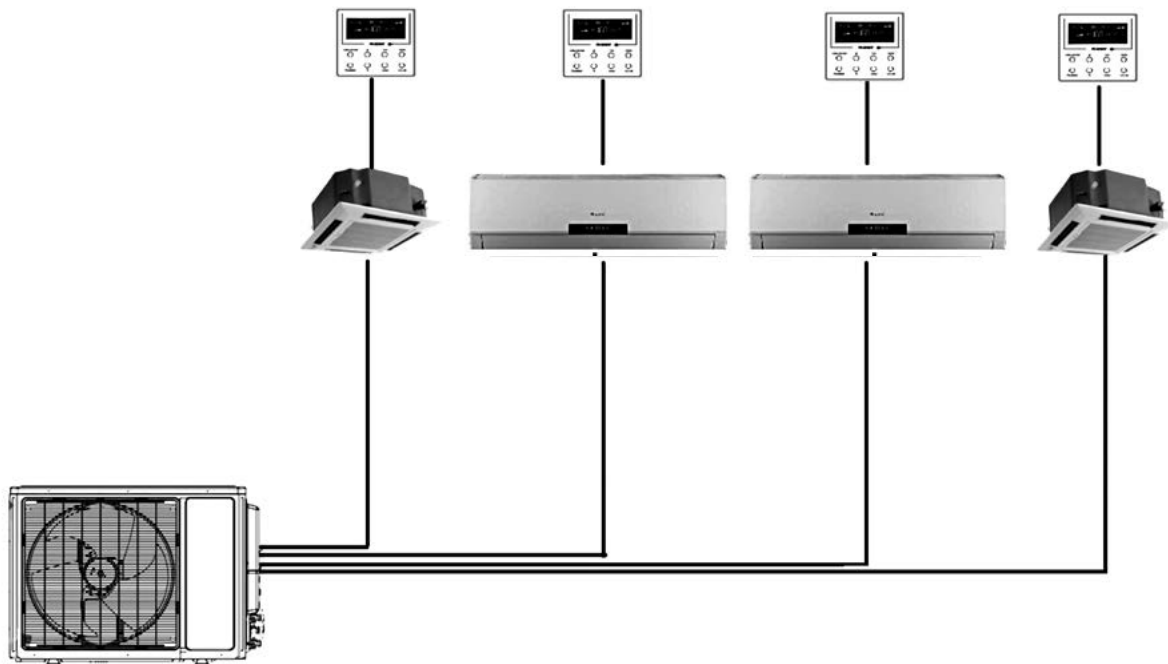

# INSTALLATION

The following is a brief XK-19 and XK-41 Wired Tether Controller installation overview. See Wired Controller Installation Manual for more detailed instructions on installation, start-up, and setup.

## Connecting Indoor Unit

Select a proper location on the wall for mounting the Tether Controller. Install switch box, if required by code. Locate the 26-ft communication cable that came with the Tether Controller. Run communication cable (as desired) between indoor unit and selected wall mounting location. Locate the Tether Controller connector in the control box area of the indoor unit. Carefully connect communication cable to indoor unit.

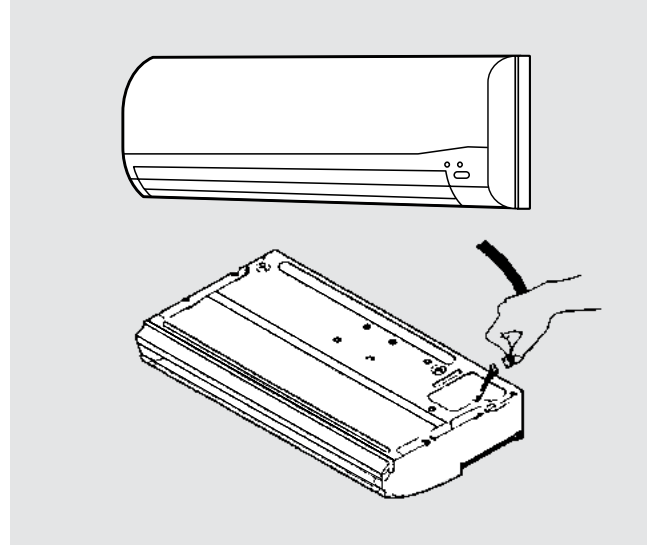

## Wired Tether Controller Installation

Pull communication cable through switch box (if one is used) and Wired Tether Controller backplate. Securely fasten backplate to the switch box or wall.

Carefully connect communication cable to rear of Wired Tether Controller panel. Push extra cable into wall and secure controller panel to backplate mounted on the wall.

**NOTE:** Do not cut and splice communication cable.

Follow the start-up setup instructions supplied with the Wired Tether Controller.

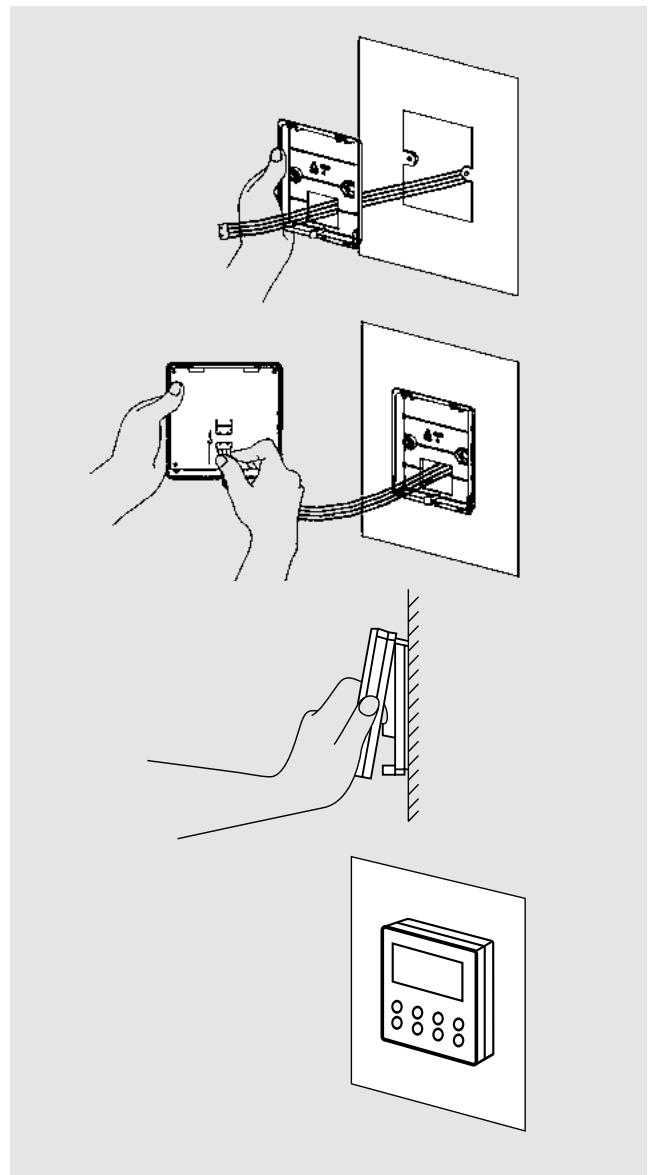

# Limited Warranty Statement



## DUCTLESS HEAT PUMP MULTI-SPLIT SYSTEMS

---

Effective on new GREE Ductless purchases on or after March 1, 2013

GREE distributor (hereinafter “Company”) warrants this product against failure due to defect in materials or workmanship under normal use and maintenance as follows. All warranty periods begin on the date of original installation. If the date cannot be verified, the warranty period begins one hundred twenty (120) days from date of manufacture. If a part fails due to defect during the applicable warranty period Company will provide a new or remanufactured part, at Company’s option, to replace the failed defective part at no charge for the part. This limited warranty is subject to all provisions, conditions, limitations and exclusions listed below.

- A warranty period of Seven (7) years on compressor to the original registered end user.
- A warranty period of Five (5) years on all parts to the original registered end user.
- A warranty period of One (1) year on the remote control provided with the original unit.
- Limited warranty applies only to systems that are properly installed by a state certified or licensed HVAC contractor, under applicable local and state law in accordance with all applicable building codes and permits; GREE installation and operation instructions and good trade practices.
- Warranty applies only to products remaining in their original installation location.
- Defective parts must be returned to the distributor through a registered servicing dealer for credit.

# LIMITATIONS OF WARRANTIES

---

All implied warranties and/or conditions (including implied warranties or conditions of merchantability and fitness for a particular use or purpose) are limited to the duration of this limited warranty, some states or provinces do not allow limitations on how long an implied warranty or condition lasts, so the above may not apply to you. The express warranties made in this warranty are exclusive and may not be altered, enlarged, or changed by any distributor, dealer, or other person, whatsoever.

## **THIS WARRANTY DOES NOT COVER:**

1. Labor or other costs incurred for diagnosing, repairing, removing, installing, shipping, servicing or handling of either defective parts, or replacement parts, or new units.
2. Product cleaning required prior to warranty service and repair.
3. Normal maintenance as outlined in the installation and servicing instructions or Owner's Manual, including filter cleaning and/or replacement and lubrication.
4. Failure, damage or repairs due to faulty installation, misapplication, abuse, improper servicing, unauthorized alteration or improper operation.
5. Failure to start due to voltage conditions, blown fuses, open circuit breakers, or damages due to the inadequacy or interruption of electrical service.
6. Failure or damage due to floods, winds, fires, lightning, accidents, corrosive environments (rust, etc.) or other conditions beyond the control of the Company.
7. Failure or damage of coils or piping due to corrosion on installations within one (1) mile of sea coast or corrosive body.
8. Parts not supplied or designated by Company, or damages resulting from their use.
9. Products installed outside continental USA and Canada.
10. Electricity or fuel costs, or increases in electricity or fuel costs for any reason whatsoever, including additional or unusual use of supplemental electric heat.
11. Any cost to replace, refill or dispose of refrigerant, including the cost of refrigerant.
12. Shipping damage or damage as a result of transporting the unit.
13. Accessories such as condensate pumps, line sets and so forth are not covered.
14. Any special, indirect or consequential property or commercial damage of any nature whatsoever. Some states or provinces do not allow the exclusion of incidental or consequential damages, so the above limitation may not apply to you.

## **FOR WARRANTY SERVICE OR REPAIR:**

Contact your installing contractor. You may find the installer's name on the equipment or in your Owner's packet.

This warranty gives you specific legal rights, and you may also have other rights which vary from state to state or province to province.

WSO021513-DLSWARR-MULTI - Rev. 10-15-14





*Specifications in this booklet are subject to change without notice.  
Manufacturer reserves the right to discontinue or modify specifications or  
designs without notice or without incurring obligations. All rights reserved.*

Cat# TETHER-1TPG Version: Original  
© 2014 Gree Electric Appliance, Inc.