

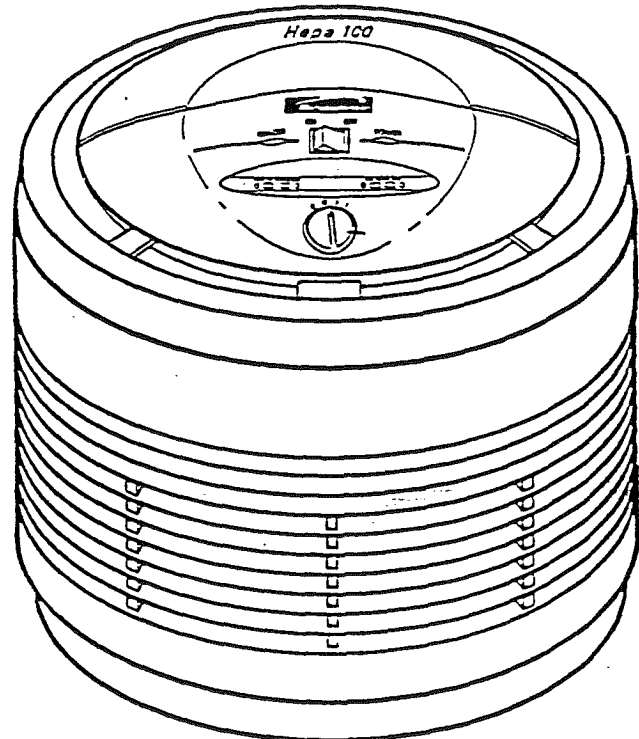

HEPA 100 AIR CLEANING SYSTEM

Model
437.83231



- Operating Instructions
- Parts List

CAUTION:

Read and follow all Safety Rules and Operating Instructions before first use of this product.

INFO-LINE

After having read this manual, if you have any questions or comments on your Kenmore air cleaner, call:

1-800-554-4558



Sears, Roebuck and Co., Hoffman Estates, IL 60179 U.S.A.

GENERAL SAFETY INSTRUCTIONS

When using electrical appliances, basic precautions should always be followed to reduce the risk of fire, electrical shock and injury to persons, including the following:

- Read all instructions before using the air cleaner.
- This product is equipped with a polarized alternating current line plug (a plug having one blade wider than the other). This plug will fit into the power outlet only one way. This is a SAFETY FEATURE. If you are unable to insert the plug fully into the outlet, try reversing the plug. If the plug should still fail to fit, contact an electrician to replace the obsolete outlet. DO NOT do anything that will defeat the safety purpose of the polarized plug.
- Always unplug the air cleaner when not in use.
- Do not operate the air cleaner with a damaged cord or plug or after the air cleaner malfunctions, has been dropped or damaged in any manner. Return the unit to Sears for examination, electrical or mechanical adjustment, or repair.
- Do not run power cord under carpeting. Do not cover cord with throw rugs, runners or the like. Arrange cord away from traffic areas and where it will not be tripped over.
- Unplug the air cleaner prior to moving, cleaning or changing the replacement filters.
- DO NOT place any foreign objects inside the air cleaner. Electric shock and injury could occur.
- Never expose your air cleaner to rain, use in damp locations or near water (for example, near bathtubs or in a wet basement).
- Never operate the air cleaner unless it is fully assembled.
- Do not use this product outdoors.
- Do not use air cleaner in areas where combustible gases or vapors are present.
- Do not block air intake or any air outlets by placing air cleaner on soft surfaces such as bedding or sofas.
- Locate the air cleaner near a power outlet and avoid using an extension cord.
- SAVE THESE IMPORTANT INSTRUCTIONS.

INTRODUCTION

Congratulations on your choice of the Kenmore HEPA Air Cleaning system. HEPA is an acronym for High Efficiency Particulate Air, which describes a fibrous media designed to remove 99.97% of particulates of 0.3 microns or larger in size. A micron is one millionth of a meter. For example, a human hair is approximately 100 microns in diameter, while pollen and plant spores are greater than 1 micron in diameter.

Air pollution can and does exist in our homes. The Kenmore HEPA air cleaner has been designed to thoroughly clean the air which WE CAN CONTROL: the air within our homes. With your Kenmore HEPA Air Cleaning System, you can provide clean and healthy air to your family, air that is free of smoke particles, dust, pollen and other pollutants.

We highly recommend that you utilize the Kenmore HEPA Air Cleaning System 24 hours each day to ensure that the air circulating through your room is continuously being cleaned and filtered.

This HEPA air cleaning system is most effective when used in a room with doors and windows closed.

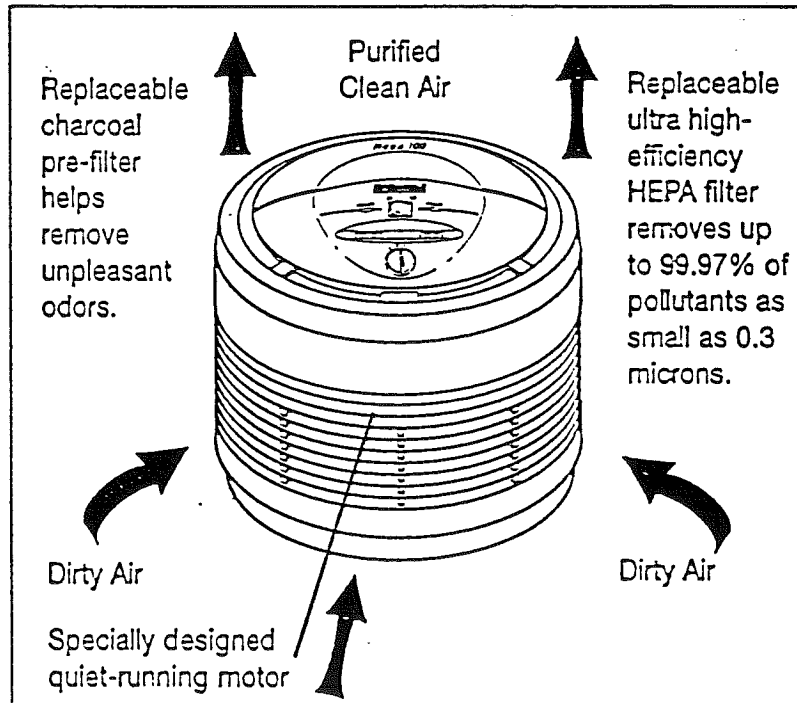

FULL ONE YEAR WARRANTY

If within one (1) year from the date of purchase, this Air Cleaner fails due to a defect in material or workmanship, Sears will repair or replace it free of charge.

This warranty applies only while this product is in use in the United States or Canada.

This warranty gives you specific legal rights and you may also have other rights which may vary from state to state.

This warranty DOES NOT cover the replacement HEPA filter or pre-filter.

Sears, Roebuck and Co.
817WA, Hoffman Estates, IL 60179

GETTING TO KNOW YOUR HEPA 100 AIR CLEANING SYSTEM

HOW YOUR FILTERING SYSTEM OPERATES:

Dirt, dust, pollen and smoke particulate-laden air is forced through our three-stage filtering system, including the ionizer, before it leaves the air cleaner.

Stage 1: Charcoal Pre-filter - Helps remove odors and harmful gases.

Stage 2: HEPA Filter - The HEPA filter will remove pollen and most other airborne particulates that affect people who suffer from allergies and upper respiratory problems.

Stage 3: Electronic IONIZER - Prior to exiting the air cleaner, the air is exposed to an IONIZER which places a negative charge on any remaining airborne particles. The negative charge given to these particulates enables them to be trapped more easily when they pass through the system again. A further benefit of the IONIZER is that it enhances indoor air "freshness".

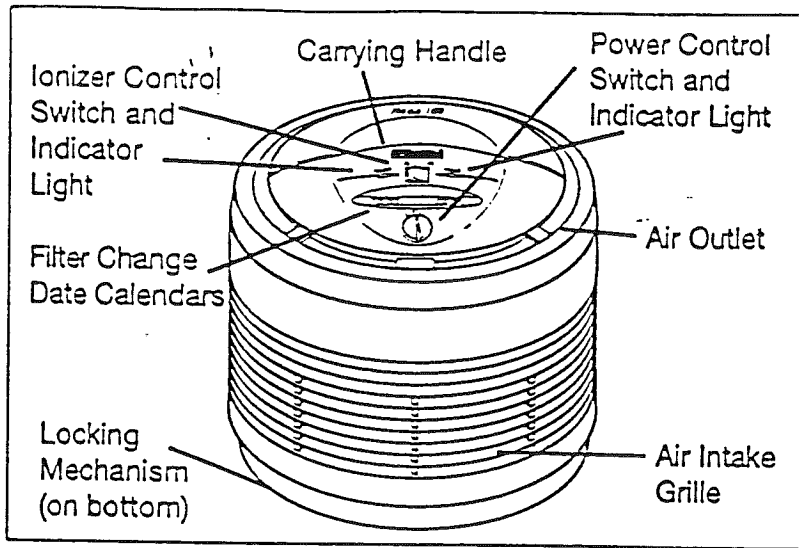

EXPLODED VIEW OF CONTROL PANEL

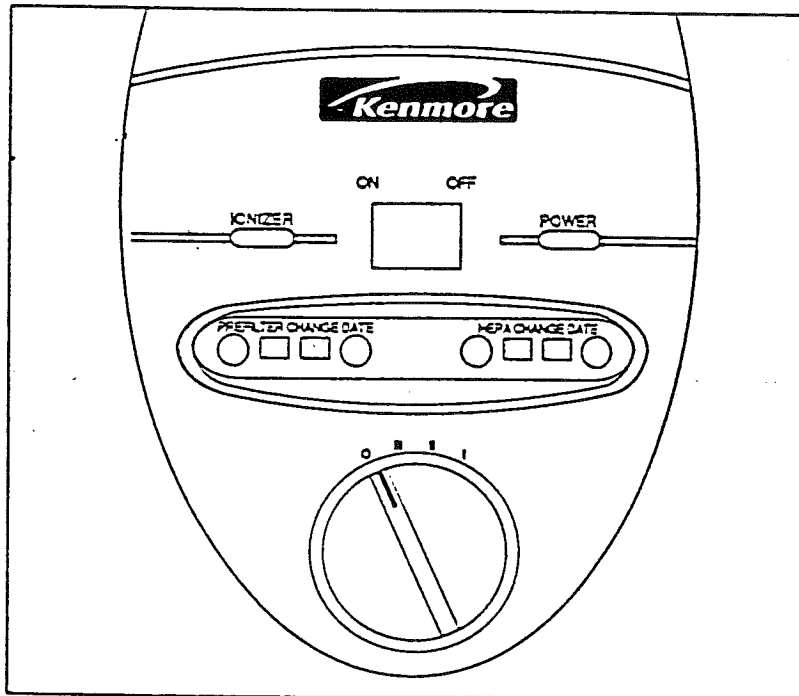

POWER CONTROL SWITCH and INDICATOR LIGHT -
 This switch will turn the air cleaner ON or OFF and has three speed selections: III (super), II (high) and I (low).

IONIZER CONTROL SWITCH and INDICATOR LIGHT-
 An ionizer ON/OFF switch is provided so that you can operate the air cleaner with or without the ionizer operating. The ionizer switch will only operate when the power switch is on. The indicator light will glow when the ionizer is powered on. The use of the ionizer will reduce the amount of airborne particulates. If the air cleaner is placed too close to a wall or is in a very polluted area, you might notice a sediment of trapped ionized pollutants build up on objects adjacent to it.



AIR INTAKE GRILLE - Dirty air is drawn in 360° into the Kenmore HEPA Air Cleaner.

AIR OUTLET - After the air has been cleaned by the HEPA filter, it is dispersed UPWARDS into the surrounding atmosphere.

CARRYING HANDLE - A convenient handle is provided to enable easy relocation of your air cleaner.

FILTER CHANGE DATE CALENDARS - Two filter change date wheels are provided as a convenient reminder when to replace the pre-filter and the HEPA filter.

SET-UP

Visually inspect the HEPA air cleaner upon removing the unit from its box. Remove and discard any packaging material. Return the unit if it shows any signs of damage or mishandling. This unit was thoroughly inspected and tested at the factory prior to packaging.

Upon start up of your Kenmore HEPA Air Cleaner, set the Pre-filter Change Date Calendar ahead 3 months and the HEPA Change Date Calendar ahead 2 years to indicate when the next filter replacement is necessary.

CAUTION: DO NOT place the air cleaner within 3 feet of any computer or any magnetically sensitive devices such as floppy disks or tapes.

ELECTRICAL HOOK-UP

Plug the air cleaner into a polarized 120 Volt AC wall outlet.

WARNING

To avoid fire or shock hazard, the HEPA air cleaner should only be plugged into a polarized 120 Volt AC outlet.

NEVER operate the HEPA air cleaning system without the HEPA filter properly installed. Permanent motor damage could result.

OPERATION

Each time the air cleaner is operated, turn the control switch to the III (super) position for a fast initial cleaning for a few seconds. Then adjust the control switch to the desired output setting:

III (super) - Maximum operation - fast initial cleaning

II (high) - Daytime operation - fast fan speed

I (low) - Night-time - quieter operation

Turn IONIZER switch ON.

CLEANING

WARNING: Prior to any cleaning operation, the air cleaner must be turned OFF and unplugged from the power outlet.

1. Clean the air cleaner with a moistened soft cloth only. DO NOT pour or splash water on the unit or use any abrasive type cleaner on it. Clean all external surfaces, especially the air intake grilles and air outlet.
DO NOT attempt to clean the filter cartridge; it is NOT washable.
2. Reposition air cleaner. Plug into operational outlet and turn ON.

FILTER CHANGE SCHEDULE

PRE FILTER (MODEL 83237) - The pre-filter should be changed every three (3) months or sooner depending upon the level of the room's air contaminants and the frequency of use.

HEPA FILTER (MODEL 83239) - The usable lifetime of the HEPA filter is 1 - 3 years depending upon the level of air contaminants in the room and the frequency of use. The air volume output will begin to decrease dramatically when the filter needs to be changed. It is advisable to have a spare filter available for later replacement.

FILTER REPLACEMENT

These specially designed filters are made for easy replacement and maximum performance.

THEY ARE NOT WASHABLE.

Step 1

Turn the HEPA air cleaner OFF and unplug the unit from the power outlet.

Step 2

Open by gently placing the air cleaner on its side and unscrewing the locking mechanism.

Step 3

Remove the base assembly from the air cleaner.

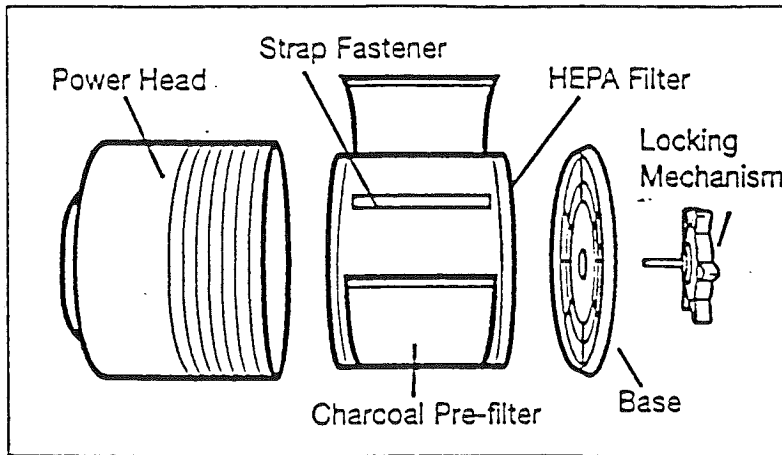

REPLACING THE CHARCOAL PRE-FILTER (Model #83237)

Step 4

Remove the filter assembly (consisting of the HEPA filter and pre-filter) from the power head.

Step 5

Remove the strap fastener and carefully remove the pre-filter and discard.

Step 6

Remove any plastic protective wrapping from the new pre-filter prior to insertion into the HEPA air cleaner. Carefully wrap the new pre-filter around the HEPA filter and secure into place with the strap fastener. Proceed to step #10.

CHANGING THE HEPA FILTER (Model #83239)

Step 7

Follow instructions through Step 6. Remove used HEPA filter assembly and discard the filter.

Step 8

Remove any protective plastic wrapping and packaging from the New HEPA filter.

Step 9

Replace the pre-filter by wrapping it around the HEPA filter and use the strap fastener to secure the pre-filter in place. Please be sure that the pre-filter has been properly installed and is laying flat around the HEPA filter.

Step 10

Place the filter assembly into the power head and install the base.

Note: The HEPA filter assembly was designed to easily fit into the power head without any orientation: there is no top or bottom to the HEPA filter.

Step 11

Lock the base into place by replacing and tightening the locking mechanism securely.

Step 12

Adjust the filter change calendar(s) to properly indicate when the next filter change is necessary.

Step 13

Turn the HEPA air cleaner upright and the HEPA air cleaner is ready for operation.

STORAGE

If you store your Kenmore HEPA Air Cleaning System for more than 30 days, we recommend that you:

1. Remove both the primary HEPA filter and the charcoal pre-filter from the unit.
2. Discard the pre-filter.
3. Wrap the HEPA filter in an air-tight plastic bag or plastic wrap. Be sure that the filter is totally sealed.

To restore the air cleaner to service:

1. Unwrap the HEPA filter.
2. Install a new activated carbon pre-filter.
3. Replace both filters in the air cleaner.

(see "Filter Replacement" section for proper installation).

Technical Specifications

Diameter:	12.5 inches	31.8 cm
Height:	11.5 inches	29.2 cm
Weight:	8.1 lbs.	3.7 kgs.
Input Voltage:	120 Volts AC, 60 Hz	
Ionization Voltage:	7500 Volts DC	

Sears reserves the right to change or modify any specification without notice.

REPLACEMENT PARTS LIST

Filter Replacement:

Charcoal Pre-filter	83237
HEPA Filter	83239

Component Parts:

Power Head	83231-1
Base	83231-2
Locking Mechanism	83231-3

CUSTOMER ASSISTANCE LINE

There are no customer-serviceable parts inside this air cleaner. If you experience any problem, please see the warranty for information. Please DO NOT attempt to repair this unit yourself. Doing so will void your warranty and could cause damage to the air cleaner or personal injury to yourself. If you have any questions concerning this appliance, please call toll free:

1-800-554-4558

Business Hours:

Mon. - Fri., 8:00 am - 10:00 pm EST,

Sat.- Sun., 8:30am - 5:00 pm EST.

HOW TO ORDER REPLACEMENT PARTS

To order replacement parts by phone, call toll free:

1-800-FON-PART (1-800-366-7278)

7am-7pm, 7 days a week

When ordering replacement parts, always give the following information:

Part Number:	See Replacement Parts List
Part Description:	See Replacement Parts List
Model Number:	437-83231
Name of the Item:	HEPA 100 Air Cleaning System

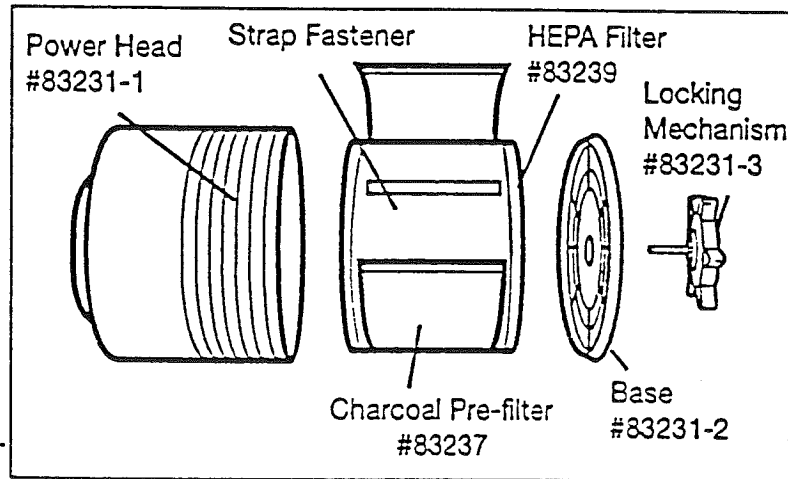

Parts Price List

Model #

437-83231

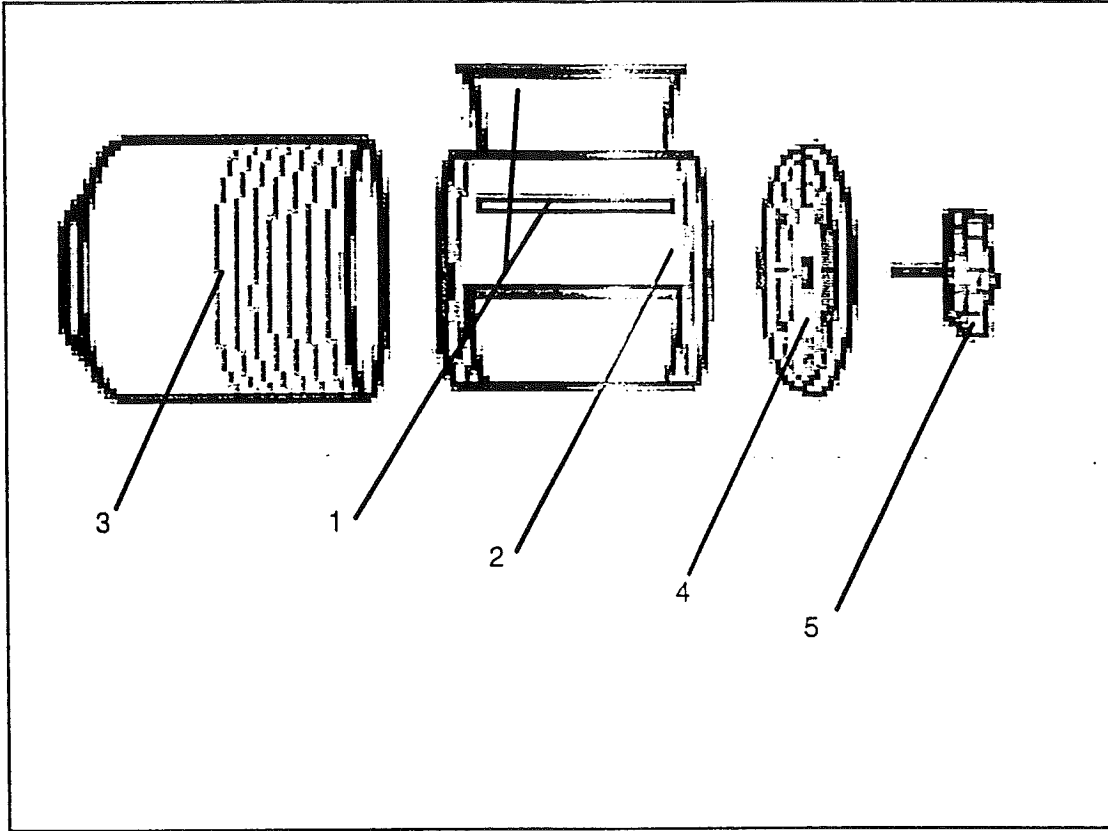

<u>Item</u>	<u>Part Number</u>	<u>Description</u>
1	83237	Replacement Activated Carbon Pre-filter with strap fastener
2	83239	Replacement HEPA Filter
3	83231-1	Powerhead Assembly
4	83231-2	Base Assembly
5	83231-3	Locking Mechanism

IB-832310 OWNERS MANUAL