

<b>EN</b>	User Manual   <b>Beverage Center</b>	<b>2</b>
<b>FR</b>	Manuel d'utilisation   <b>Centre de boissons</b>	<b>13</b>
<b>ES</b>	Manual de usuario   <b>Centro de bebidas</b>	<b>26</b>



## Welcome to our family

Thank you for bringing Frigidaire into your home! We see your purchase as the beginning of a long relationship together.

This manual is your resource for the use and care of your product. Please read it before using your appliance. Keep it handy for quick reference. If something doesn't seem right, the troubleshooting section will help you with common issues.

FAQ, helpful tips and videos, cleaning products, and kitchen and home accessories are available at <http://www.frigidaire.com>.

We are here for you! Visit our website, chat with an agent, or call us if you need help. We may be able to help you avoid a service visit. If you do need service, we can get that started for you.

Let's make it official! Be sure to register your product.

## CONTENTS

1. IMPORTANT SAFETY INFORMATION.....	2
2. PRODUCT OVERVIEW.....	5
3. INSTALLATION.....	5
4. CONTROLS AND SETTINGS.....	8
5. STORAGE FEATURES.....	8
6. CARE AND CLEANING.....	9
7. TROUBLESHOOTING.....	9
8. LIMITED WARRANTY.....	11

# 1. IMPORTANT SAFETY INFORMATION

## 1.1 Keep a record for quick reference

Model number

.....

Serial number

.....

Purchase date

.....

## 1.2 Serial number location

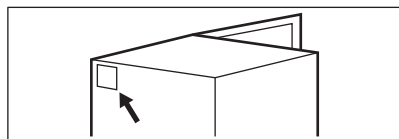

### **WARNING!**

You must follow these guidelines to ensure that your refrigerator's safety mechanisms are operating correctly.

## 1.3 Safety definitions



This is the safety alert symbol. It is used to alert of potential personal injury hazards. Obey all safety messages that follow this symbol to avoid possible injury or death.

## **DANGER**

DANGER indicates an imminently hazardous situation which, if not avoided, will result in death or serious injury.

## **WARNING!**

WARNING indicates a potentially hazardous situation which, if not avoided, could result in death or serious injury.

## **CAUTION!**

CAUTION indicates a potentially hazardous situation which, if not avoided, may result in minor or moderate injury.

## **IMPORTANT**

IMPORTANT indicates installation, operation or maintenance information which is important but not hazard-related.

## 1.4 Child safety

This appliance is not intended for use by persons (including children) with reduced physical, sensory or mental capabilities, or lack of experience and knowledge, unless they have been given supervision or instruction concerning use of the appliance by a person responsible for their safety.

Destroy or recycle the carton, plastic bags, and any exterior wrapping material immediately after the refrigerator is unpacked.

Children should never use these items to play. Cartons covered with rugs, bedspreads, plastic sheets or stretch wrap may become airtight chambers, and can quickly cause suffocation.

## 1.5 Important safety instructions

### **DANGER**



DANGER Risk of fire or explosion. Flammable refrigerant used. Do not use mechanical devices to defrost refrigerator. Do not puncture refrigerant tubing.

DANGER Risk of fire or explosion. Flammable refrigerant used. To be repaired only by trained service personnel. Use only manufacturer-authorized service parts. Any repair equipment used must be designed for flammable refrigerants. Follow all manufacturer repair instructions. Do not puncture refrigerant tubing.

### **CAUTION!**



CAUTION Risk of fire or explosion due to puncture of refrigerant tubing. Follow handling instructions carefully. Flammable refrigerant used.

This appliance is for beverages storage only and should not be used for any other purpose.

Do not store or use gasoline or other flammable vapors and liquids in the vicinity of this or any other appliance.

Do not store explosive substances such as aerosol cans with a flammable propellant in this appliance.

Do not operate the refrigerator in the presence of explosive fumes. Avoid contact with any moving parts of automatic ice maker.

Remove all staples from the carton. Staples can cause severe cuts, and also destroy finishes if they come in

contact with other appliances or furniture.  
Do not place heavy objects on top of the appliance.

**⚠ WARNING!**

Do not use electrical appliances inside the food storage compartments of the appliance unless they are of the type recommended by the manufacturer.

**⚠ WARNING!**

Keep ventilation openings, in the appliance enclosure or in the built-in structure, clear of obstruction.

**⚠ WARNING!**

Do not damage the refrigerant circuit.

**⚠ WARNING!**

To avoid a hazard due to instability of the appliance, it must be fixed in accordance with the instructions.

**⚠ WARNING!**

CALIFORNIA RESIDENTS ONLY  
WARNING! Cancer and Reproductive Harm <http://www.P65Warnings.ca.gov>

## 1.6 Proper disposal of your refrigerator or freezer

**⚠ CAUTION!**



CAUTION Risk of fire or explosion. Dispose of refrigerator properly in accordance with the applicable federal or local regulations. Flammable refrigerant used.

### Risk of child entrapment

Child entrapment and suffocation are not problems of the past. Junked or abandoned refrigerators or freezers are still dangerous – even if they will sit for “just a few days”. If you are getting rid of your old refrigerator or freezer, follow the

instructions below to help prevent accidents.

We strongly encourage responsible appliance recycling/disposal methods. Check with your utility company or visit <http://www.energystar.gov/recycle> for more information on recycling your old refrigerator.

### Before you throw away your old refrigerator/freezer:

- Remove doors.
- Leave shelves in place so children may not easily climb inside.
- Have it removed by a qualified service technician.

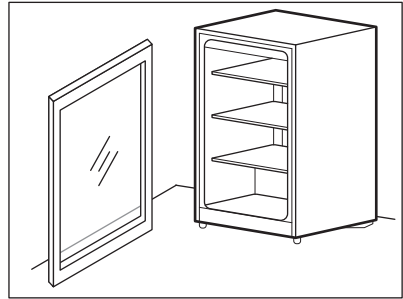

## 1.7 Electrical information

- The appliance must be plugged into its own dedicated 115 Volt, 60 Hz., 15 Amp, AC only electrical outlet. The power cord of the appliance is equipped with a three-prong grounding plug for your protection against electrical shock hazards. It must be plugged directly into a properly grounded three-prong receptacle. The receptacle must be installed in accordance with local codes and ordinances. Consult a qualified electrician. Do not use an extension cord or adapter plug.

**⚠ WARNING!**

Avoid fire hazard or electric shock.

- If the power cord is damaged, it should be replaced by an authorized service technician to prevent any risk.

- Never unplug the appliance by pulling on the power cord. Always grip the plug firmly, and pull straight out from the receptacle to prevent damaging the power cord.
- Unplug the appliance before cleaning and before replacing the AC LED light bulb to avoid electrical shock. Use only a 5-watt or less AC LED light bulb.
- Performance may be affected if the voltage varies by 10% or more. Operating the appliance with insufficient power can damage the compressor. Such damage is not covered under your warranty.
- Do not plug the unit into an electrical outlet controlled by a wall switch or pull cord to prevent the appliance from being turned off accidentally.
- Do not pinch, knot, or bend the power cord in any manner.

### **⚠ WARNING!**

When positioning the appliance, ensure the supply cord is not trapped or damaged.

Do not locate multiple portable socket-outlets or portable power supplies at the rear of the appliance.

### **⚠ WARNING!**

Do not, under any circumstances, cut, remove, or bypass the grounding prong (A). Always use the power cord with a three-prong grounded plug and grounding type wall receptacle.



## 2. PRODUCT OVERVIEW

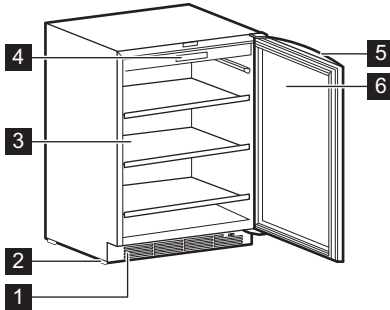

- 1 Toe grill
- 2 Adjustable feet
- 3 Shelves
- 4 Appliance control
- 5 Handle
- 6 Glass door

## 3. INSTALLATION

This User Manual provides general installation and operating instructions for your model. We recommend using a service or kitchen contracting professional to install your appliance. Use the appliance only as instructed in this User Manual. Before starting the appliance, follow these important first steps.

### 3.1 Location

- If possible, place the appliance out of direct sunlight and away from the

range, dishwasher, or other heat sources.

- The appliance must be installed on a floor that is level and strong enough to support a fully loaded appliance.



## WARNING!

This appliance is intended for use in residential household and similar interior applications such as:

- Kitchen / kitchenette
- Pantry room
- Basement
- Enclosed garage
- Other interior residential type environments



## NOTE

Do not block the lower front of the appliance.

Sufficient air circulation is essential for the proper operation of the appliance.



## NOTE

The exterior walls of the appliance may become warm as the compressor transfers heat from the inside. The temperatures may be even 30°F higher than the room temperature. In hotter climates it is important to allow enough space for air circulation around the appliance.

## 3.2 Dimensions

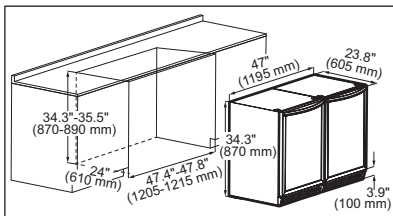
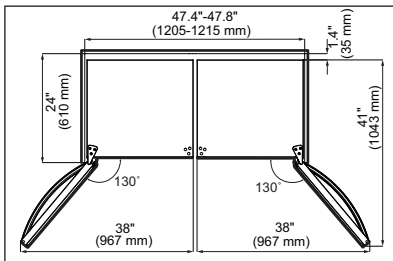

## 3.3 Leveling

When positioning the appliance, ensure that it is level, with all bottom corners resting firmly on a solid floor. You can adjust this using the two leveling feet

located at the front bottom of the appliance.

## 3.4 Reversing the Door Swing



## IMPORTANT

Save all the removed parts to do the reinstallation of the door.

1. Remove top cap. Remove 3 screws that hold the upper hinge to the top of the cabinet. Carefully remove top hinge.

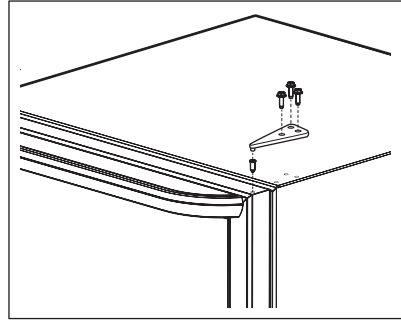

2. Lift the door up off of the bottom hinge and place it on a padded surface to avoid scratching.
3. Remove screws from each side of toe grille and transfer the plastic grille insert to the gap on the opposite side.

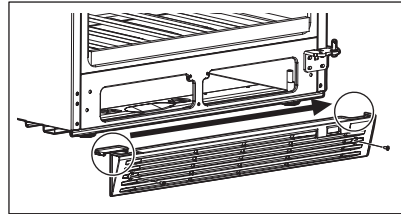

4. Remove the 3 button plugs from the upper left corner and transfer them to the holes on the opposite side. Press firmly into the holes.
5. Remove the 3 screws that hold the bottom hinge to the lower end of the cabinet. Remove the 3 button plugs from the lower corner and transfer to holes where the bottom hinge was just removed.

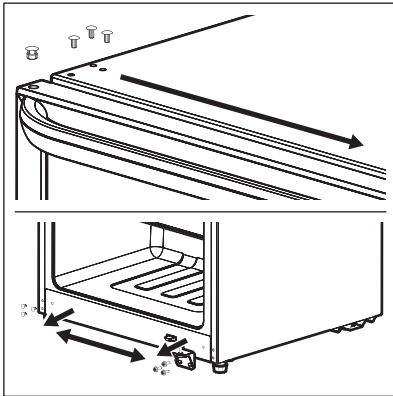

6. Unscrew pins from both hinges and transfer to threaded hole on the opposite side. Reinstall the bottom hinge in the left corner of the cabinet. Use the same 3 screws removed in step 4.

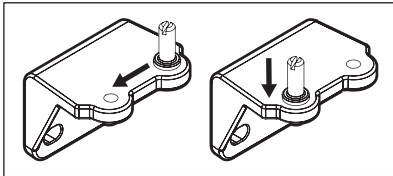

7. On the bottom edge of the door, transfer the door stop bracket and bushing to the holes on the opposite side.

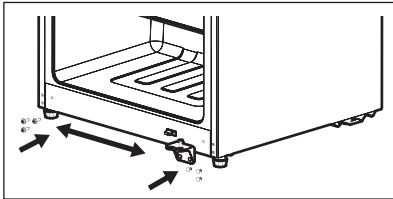

8. On top edge of the door, transfer the button plugs and bushing to the hole on the opposite site.

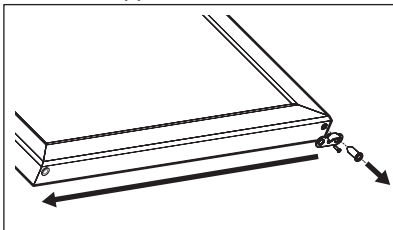

9. Place the bottom left corner of the door onto the lower hinge, then install top hinge to the cabinet. Make sure the door is level and it seals properly against the cabinet. Securely fasten the 3 screws and snap top cap back onto the hinge.

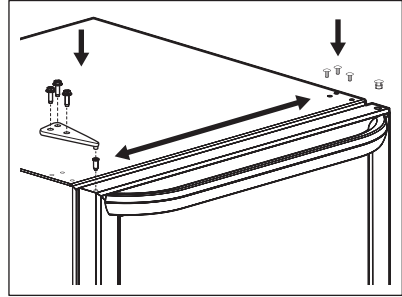

10. Reinstall the toe grille.

### 3.5 Door Handle Installation

1. Set handle over the 2 mounting studs at the top of the door.
2. Use hex head screw driver or allen wrench to tighten set screws from the bottom to secure the handle to the door.

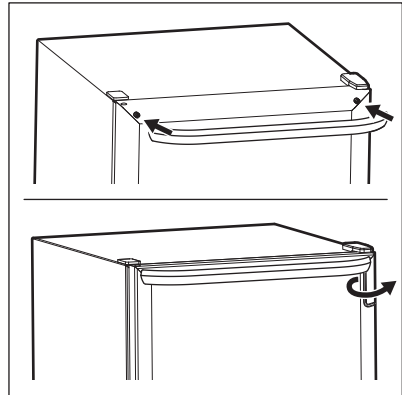

## 4. CONTROLS AND SETTINGS

### 4.1 Appliance Control

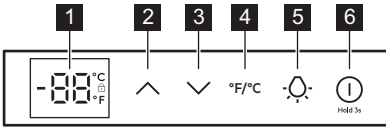

- 1 Display**
- 2 Temperature increase button**
- 3 Temperature decrease button**
- 4 Unit change button**  
Press to change the displayed temperature unit (°F/°C).
- 5 Light button**  
Press the button to keep the light on while the door is closed. When the function is disabled, the light turns on automatically when the door is open and turns off when the door is closed.
- 6 Standby Mode button**  
Press and hold for 3 seconds to activate the mode. During this mode, the appliance does not operate and power consumption is minimized.

### 4.2 Temperature Control

To set the temperature, tap the Temperature increase or decrease button.

The temperature settings range from 34°F (1°C) to 50°F (10°C).

### 4.3 Saving Energy

For optimal appliance performance:

- Place the appliance in the coolest area of the well-ventilated room, away from heat-producing appliances, heating ducts, and direct sunlight.
- Do not overload the appliance or block the air vents. It can cause the compressor to run longer, leading to higher energy consumption.
- Do not line shelves with aluminum foil, wax paper or paper towel. Liners interfere with cold air circulation, reducing the appliance efficiency.
- Wipe containers dry before placing in the appliance to prevent moisture build-up.
- Organize the appliance to minimize door openings. Take out all needed items at once and close the door promptly.

## 5. STORAGE FEATURES

### 5.1 Can Arrangement

- Ensure cans do not touch the rear panel to allow proper air circulation.
- Beverage storage capacity may vary depending on the size and shape of the containers. Oversized or irregularly shaped cans or bottles may reduce the maximum number of beverages that can be stored.

You can store up to 185 cans in the appliance.

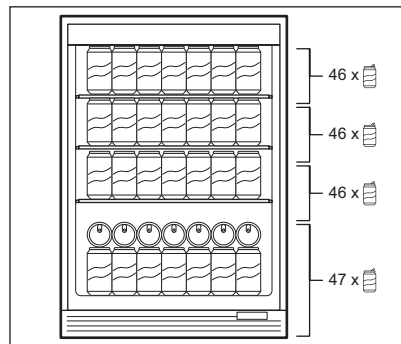

## 6. CARE AND CLEANING

### 6.1 Care & Cleaning Tips

Part	What to use	Tips and precautions
Interior and door liners	<ul style="list-style-type: none"><li>• Soap and water</li><li>• Baking soda and water</li></ul>	Use 2 tablespoons of baking soda in 1 quart of warm water. Be sure to wring excess water out of sponge or cloth before cleaning around controls, light bulb or any electrical part.
Door gaskets	Soap and water	Wipe gaskets with a clean soft cloth.
Toe grille	<ul style="list-style-type: none"><li>• Soap and water</li><li>• Mild liquid sprays</li><li>• Vacuum attachment</li></ul>	Vacuum dust from front of toe grille. Remove toe grille (refer to Installation). Vacuum backside, wipe with sudsy cloth or sponge. Rinse and dry.
Exterior	<ul style="list-style-type: none"><li>• Soap and water</li></ul>	Never use chloride or cleaners with bleach to clean stainless steel. Always clean, wipe and dry with the grain to prevent scratching. Wash the rest of the cabinet with warm water and mild liquid detergent. Rinse well, and wipe dry with a clean soft cloth.

### 6.2 Vacation and moving tips

#### Short vacations

- Leave the appliance operating during vacations of three weeks or less.
- Use all perishable items from the appliance compartment.

#### Long vacation

- Remove all food and ice if you will be gone one month or more.
- Unplug the appliance.
- Clean interior thoroughly.
- Leave both doors open to prevent odors and mold build-up. Block doors open if necessary.

#### Moving

- Unplug the appliance
- Remove all food and ice.
- Recommend use of a handcart, load from the side.
- Adjust rollers all the way up to protect them during sliding or moving.
- Pad cabinet to avoid scratching surface.

## 7. TROUBLESHOOTING

Let us help you troubleshoot your concern! This section will help you with common issues. If you need us, visit our website, chat with an agent, or call us. We may be able to help you avoid a service visit. If you do need service, we can get that started for you!

Visit [Frigidaire.com](http://Frigidaire.com) or call toll-free 1-800-374-4432.

## Appliance operation

Concern	Potential cause	Common solution
Appliance does not run.	The appliance is unplugged or the plug is loose.	Ensure plug is tightly pushed into outlet.
	The appliance is turned off.	Refer to Controls and Settings.
	House fuse blown or tripped circuit breaker.	Check/replace fuse with a 15 amp time-delay fuse. Reset circuit breaker.
	Power outage.	Check house lights. Call local electric company.
	The appliance has recently been disconnected for a period of time.	It takes 4 hours for the appliance to cool down completely.
Appliance seems to run too much or too long.	Room or outside temperature is hot.	It is normal for the appliance to work longer under these conditions.
	Doors are opened too frequently or too long.	Warm air entering the appliance causes it to run more. Open doors less often.
	Door may be slightly open.	Close and properly align the door.
	The set temperature is too low.	Set a higher temperature. Allow 24 hours for temperature to stabilize.
	Refrigerator/freezer gasket is dirty, worn, cracked, or poorly fitted.	Clean or change gasket. Leaks in door seal cause the appliance to run longer in order to maintain set temperatures.

## Water/Moisture/Frost

Concern	Potential cause	Common solution
Moisture collects on the outside or inside of the appliance.	Weather is hot and humid.	This is normal.
	Door is slightly open, causing cold air from inside refrigerator to meet warm air from outside.	Moisture collects on inside of refrigerator walls.
	The door may not be closed properly.	Ensure the door and gasket are correctly aligned.

## Odor in the appliance

Concern	Potential cause	Common solution
Odor in the appliance.	The interior needs cleaning.	Clean the interior with a sponge, warm water, and baking soda solution. Refer to Care and Cleaning

## Door problems

Concern	Potential cause	Common solution
Door does not close.	The appliance is not level and rocks when moved slightly.	This condition may force the appliance out of square and cause the door to become misaligned. Refer to Leveling in Installation.

## Lighting

Concern	Potential cause	Common solution
The lighting is off.	The appliance is not receiving electrical power.	Ensure plug is tightly pushed into outlet. Check/replace fuse with a 15 amp time-delay fuse.

## Sound and noise

Concern	Potential cause	Common solution
Increased noise levels when the appliance is operating.	The increased storage capacity and improved temperature stability result in a louder compressor during operation.	This is normal. When the surrounding noise level is low, you may hear the compressor running.
There are longer sound durations when the compressor comes on.	The appliance operates at higher pressures when it first turns on.	This is normal. The sound decreases or vanishes as the appliance operates.
Popping or cracking sound when compressor comes on.	Metal parts expand and contract, similar to hot water pipes.	This is normal. The sound decreases or vanishes as the appliance operates.
Bubbling or gurgling sound, similar to water boiling.	Refrigerant is circulating throughout the system to cool the appliance.	This is normal.
Vibrating or rattling noise.	The appliance is not level. It rocks on the floor when it is moved slightly.	Level the appliance. Refer to Leveling in Installation.
	Floor is uneven or weak. The appliance rocks on the floor when it is moved slightly.	Ensure the floor can adequately support the appliance. Refer to Leveling in Installation.

## 8. LIMITED WARRANTY

Your appliance is covered by a one year limited warranty. For one year from your date of delivery, Electrolux will pay all costs for repairing or replacing any parts of this appliance that prove to be defective in materials or workmanship when such appliance is installed, used and maintained in accordance with the provided instructions.

### Exclusions

This warranty does not cover the following:

1. Products with original serial numbers that have been removed, altered or cannot be readily determined.
2. Product that has been transferred from its original owner to another party or removed outside the USA or Canada.
3. Rust on the interior or exterior of the unit.
4. Products purchased "as-is" are not covered by this warranty.
5. Food loss due to any refrigerator or freezer failures.
6. Products used in a commercial setting.
7. Service calls which do not involve malfunction or defects in materials or workmanship, or for appliances not in ordinary household use or used other than in accordance with the provided instructions.
8. Service calls to correct the installation of your appliance or to instruct you how to use your appliance.
9. Expenses for making the appliance accessible for servicing, such as removal of trim, cupboards, shelves, etc., which are not a part of the appliance when it is shipped from the factory.
10. Service calls to repair or replace appliance light bulbs, air filters, water filters, other consumables, or knobs, handles, or other cosmetic parts.

11. Surcharges including, but not limited to, any after hour, weekend, or holiday service calls, tolls, ferry trip charges, or mileage expense for service calls to remote areas, including the state of Alaska.
12. Damages to the finish of appliance or home incurred during transportation or installation, including but not limited to floors, cabinets, walls, etc.
13. Damages caused by: services performed by unauthorized service companies; use of parts other than genuine Electrolux parts or parts obtained from persons other than authorized service companies; or external causes such as abuse, misuse, inadequate power supply, accidents, fires, or acts of God.

**DISCLAIMER OF IMPLIED WARRANTIES; LIMITATION OF REMEDIES**

CUSTOMER'S SOLE AND EXCLUSIVE REMEDY UNDER THIS LIMITED WARRANTY SHALL BE PRODUCT REPAIR OR REPLACEMENT AS PROVIDED HEREIN. CLAIMS BASED ON IMPLIED WARRANTIES, INCLUDING WARRANTIES OF MERCHANTABILITY OR FITNESS FOR A PARTICULAR PURPOSE, ARE LIMITED TO ONE YEAR OR THE SHORTEST PERIOD ALLOWED BY LAW, BUT NOT LESS THAN ONE YEAR. ELECTROLUX SHALL NOT BE LIABLE FOR CONSEQUENTIAL OR INCIDENTAL DAMAGES SUCH AS PROPERTY DAMAGE AND INCIDENTAL EXPENSES RESULTING FROM ANY BREACH OF THIS WRITTEN LIMITED WARRANTY OR ANY IMPLIED WARRANTY. SOME STATES AND PROVINCES DO NOT ALLOW THE EXCLUSION OR LIMITATION OF INCIDENTAL OR CONSEQUENTIAL DAMAGES, OR LIMITATIONS ON THE DURATION OF IMPLIED WARRANTIES, SO THESE LIMITATIONS OR EXCLUSIONS MAY NOT APPLY TO YOU. THIS WRITTEN WARRANTY GIVES YOU SPECIFIC LEGAL RIGHTS. YOU MAY ALSO HAVE OTHER RIGHTS THAT VARY FROM STATE TO STATE.

**If You Need Service**

Keep your receipt, delivery slip, or some other appropriate payment record to

establish the warranty period should service be required. If service is performed, it is in your best interest to obtain and keep all receipts. Service under this warranty must be obtained by contacting Electrolux at the addresses or phone numbers below.

This warranty only applies in the USA and Canada. In the USA, your appliance is warranted by Electrolux Major Appliances North America, a division of Electrolux Consumer Products, Inc. In Canada, your appliance is warranted by Electrolux Canada Corp. Electrolux authorizes no person to change or add to any obligations under this warranty. Obligations for service and parts under this warranty must be performed by Electrolux or an authorized service company. Product features or specifications as described or illustrated are subject to change without notice.

**USA**

**1-800-374-4432**

Frigidaire

10200 David Taylor Drive

Charlotte, NC 28262

**Canada**

**1-800-265-8352**

Electrolux Canada Corp.

5855 Terry Fox Way

Mississauga, Ontario, Canada L5V 3E4



