



COF6400WS

Professional Countertop Convection Oven

Instruction Manual

This manual contains important information regarding your Adcraft unit. Please read this manual thoroughly prior to equipment set-up, operation, and maintenance. Failure to comply with regular maintenance guidelines outlined in this manual may void the warranty.

WARNINGS

- Do not touch any hot surfaces.
- This appliance is equipped with a three prong grounding type plug for your protection against shock hazard and should be plugged directly into a properly grounded three prong receptacle.
- Do not immerse unit, cord or plug in liquid at any time.
- Unplug cord from outlet when not in use and before cleaning.
- Do not operate unattended.
- Do not use this unit for anything other than intended use.
- Do not use outdoors.
- Do not clean unit with a water stream or jet.
- Always use on a firm, dry and level surface at least 12" from walls or any other obstruction.
- Do not use if unit has a damaged cord or plug, in the event the appliance malfunctions, or has been damaged in any manner.
- Keep children and animals away from unit.
- Any incorrect installation, alterations, adjustments and/or improper maintenance can lead to property loss and injury.
- All repairs should be done by authorized professionals only.
- Ensure that the designated power supply is adequate for continual usage and the voltage is correct.
- This product is a commercial machine that needs to be operated by a trained cook. Not applicable for home use.
- Do not spray water directly onto the product during cleaning. Water may conduct electricity, which may cause electric shock.

INSTALLATION

1. The appliance should be placed in a clean and flat area. Do not install it directly onto the floor. Please keep a minimum distance of 6" from non-combustible materials on each side, and 12" from non-combustible objects (e.g. walls, windows, etc.) behind the unit.
2. Check the connection, voltage and safety grounding after installation.
3. The unit should be kept away from all flammable and explosive objects. The ambient temperature should be below 113°F and the relative humidity should be below 85%.
4. Installation should be performed by a professional technician only.

Electric Connection:

1. The supply voltage should correspond with the working voltage of the appliance.
2. There is an earth screw at rear of the furnace body, which should be connected with a copper wire that is grounded and complies with safety regulations.
3. The wiring should be equipped with a disconnecting switch and installed by a qualified electrician.

Water Pipe Connection:

1. Connect the solenoid valve at rear with a 1/2 inch water pipe. Please connect tightly to prevent leakage.
2. Flush water into the pipe to remove the iron scale. The water hardness should be 0.5-5 (to prevent water scale) and the pressure should be 50-200 kPa.

OPERATION

1. Before using, please check that the plug corresponds to the correct outlet being used.
2. Plug in the unit and set the timer to manual setting. Set the thermostat to 392°F to heat for 10 minutes. (When first using, please clean the chamber with hot water, then heat for 30 minutes at 392°F to eliminate smells from oils in manufacturing.) 3. Open the door and put the baking trays with prepared food onto the rack inside, then close the door and set the thermostat to the desired temperature and set the timer to the desired time. (When the food is in the oven, please make sure that distance between the bottom of upper tray and the top of next tray is in at least 1.5" for proper hot-air circulation.)

3. If the food inside the oven is drying out, press the spray switch button during cooking to add moisture inside the chamber.
4. When the timer goes off, the unit will shut down automatically. Set the timer to manual setting, prior to cooking, to keep the oven running continuously.

Note:

The exterior of this oven gets hot during usage. To prevent injuries and burns, do not touch the appliance during operation. For best results while baking, leave a 1.5" space between the food racks for proper air flow inside the oven chamber. The maximum capacity for each food rack is 22 lbs.

CONTROL PANEL

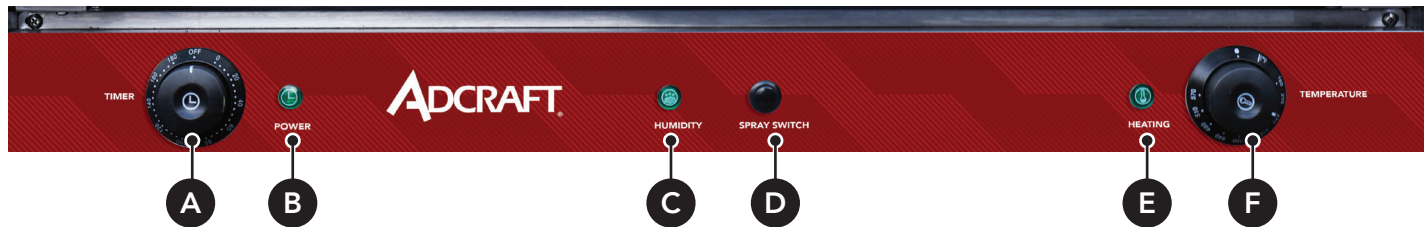

- "A": Timer - controls cooking and passes power.
- "B": Power indicator - displays when the timer is engaged.
- "C": Humidity - on when the spray switch is engaged.
- "D": Spray button - push down to start spraying and release to stop.
- "E": Heating - on when the unit is heating.
- "F": Temperature - controls the internal temperature, the max temperature is 572°F.

REGULAR MAINTENANCE & CLEANING

- Checking the unit regularly will help prevent serious accidents from happening
 - Stop using it immediately if you feel that there are some problems with the unit
 - Inspect the unit before each use daily
1. Before cleaning, turn off the unit and let the unit cool down completely.
 2. Open the door and take out the interior racks. Clean them with water and detergent.
 3. After working every day, clean the internal and external surfaces and inside chamber with a wet towel containing non-corrosive detergent. Do not spray the machine directly with water.
 4. After cleaning, put the racks back into the oven.
 5. If the appliance is not going to be used for a long time, clean it and store it in a well-ventilated place without corrosive gases.

TROUBLESHOOTING

PROBLEM	SYMPTOM	SOLUTION
The circuit breaker trips	The electrical component leaks	Check the leakage component, repair or replace it
Oven takes too long to heat up	1. The supply voltage is too low 2. The fan or heating element is defective	1. Replace the fuse 2. Replace the fan or heating element
The pump has stopped circulating	Problem with water supply or solenoid valve	1. Check water supply. 2. Replace solenoid valve



CIRCUIT DIAGRAM

AC/L.N/230V/50-60Hz/6.4kW

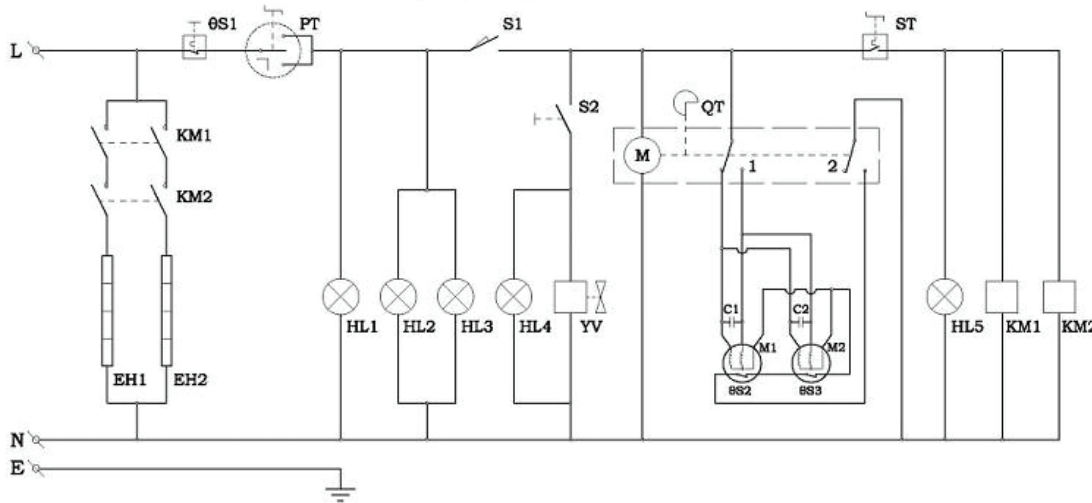

KM1.KM2-----A.C. contactor
EH1.EH2-----heating element
θS1-----over-temperature protector
PT-----timer

S1-----door switch
S2-----water inlet switch
QT-----program controller
C1.C2-----capacitor

HL1-----power indicator
HL2.HL3-----chamber lamp
HL4-----water indicator
YV-----water inlet solenoid valve

M1.M2-----fan motor
θS1.θS2-----motor thermal breaker
ST-----thermostat
HL5-----heating indicator

EXPLODED DRAWING

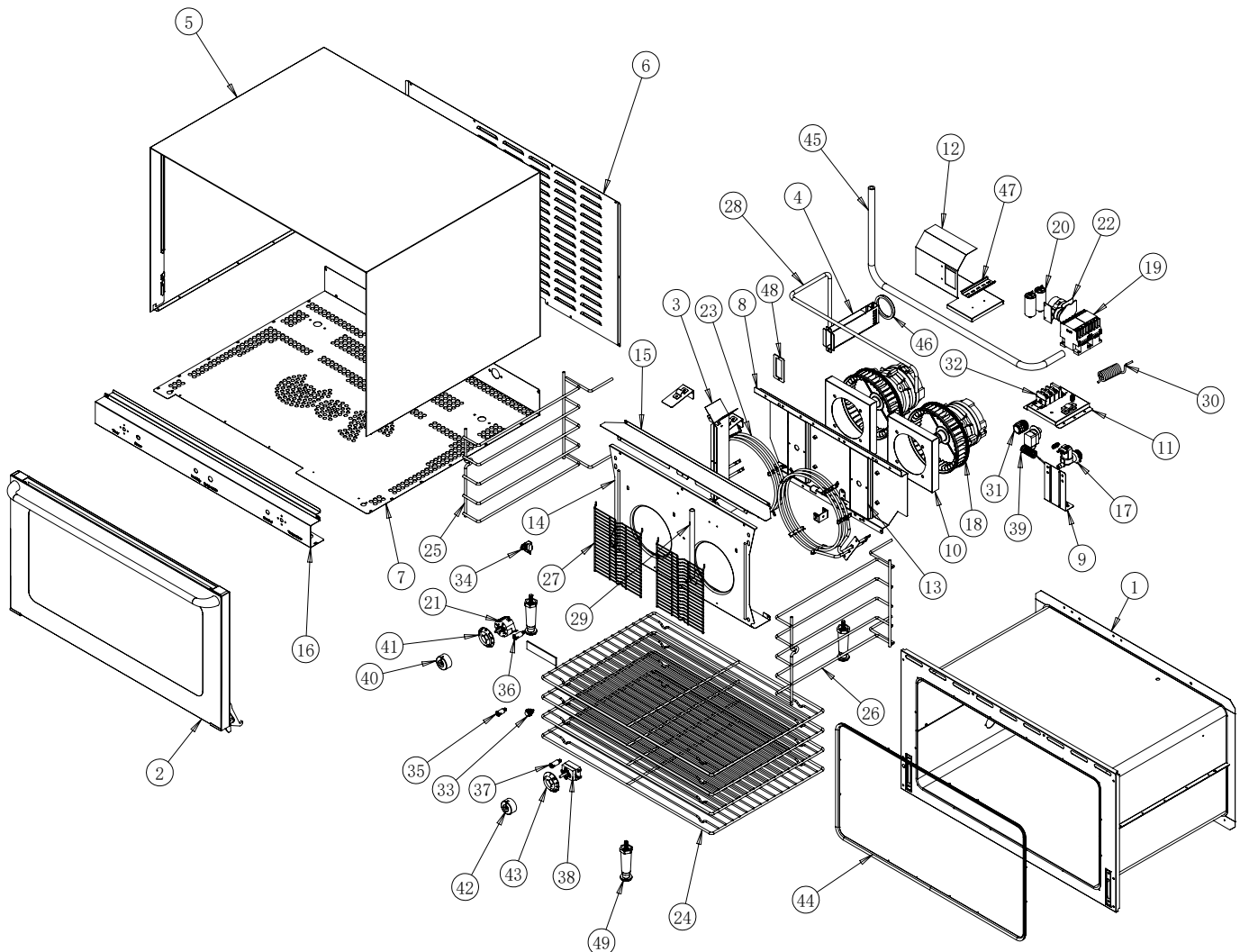

EXPLODED PART LIST

NUMBER	DESCRIPTION	QTY.
1	Chamber Assembly	1
2	Door Assembly	1
3	Motor Blade Middle Septum Plate Assembly	1
4	Flue Assembly	1
5	Coaming Plate	1
6	Back Cover Plate	1
7	Bottom Plate	1
8	Motor Installation Plate	1
9	Rear Leg Supporting Plate (welding with M10 nuts)	2
10	Motor Insulation Plate	2
11	Terminal Installation Plate	1
12	Electronic Components Installation Plate	1
13	Motor Installation Strengthening Plate	2
14	Motor Baffle Plate	1
15	Motor Top Baffle Plate	1
16	Control Panel (After Silk-screen)	1
17	Solenoid valve	1
18	Motor	2
19	AC contactor	2
20	Capacitance	2
21	180 Minutes Timer	1
22	Time Controller	1
23	Heating Element Assembly	2
24	Rack	4
25	Rack left support	1
26	Rack right support	1
27	Motor Blade Barrier Net	2
28	Water Inlet Pipe	1
29	Spray Pipe	1
30	Power Cord (3*4 square meters)	1
31	Power cord socket	1
32	Ceramic three-position terminals (with N/L identification)	1
33	Spray switch	1
34	Micro-switch	1
35	Green indicator (for water spray)	1
36	Green indicator (with time mark)	1
37	Green indicator (with temperature mark)	1
38	Thermostat	1
39	High-limit	1
40	Timer knob(with time mark)	1
41	180 Minutes Timer knob base	1
42	Thermostat knob (with temperature mark)	1
43	Thermostat knob base	1
44	Door gasket (16 pins)	1
45	Silicone pipe	1
46	Y-shaped piston ring	1
47	Steel guide	1
48	Flue silicone gasket	1
49	Leg	4

1-YEAR LIMITED WARRANTY

Admiral Craft Equipment Corp. (the "Company") warrants this product (the "Product") will be free from failures in material and workmanship for one (1) year from the date of original purchase with proof of purchase, provided that the Product is operated and maintained in conformity with the Owner's Manual. This Limited Warranty is non-transferable. During this period, your exclusive remedy is repair or replacement without charge of the Product or any component found to be defective at the Company's discretion. If the Product or any component is no longer available, the Company will replace it with a similar one of equal or greater value. This Limited Warranty is void if the Product is used with voltage other than 120 Volts. **THIS WARRANTY IS IN LIEU OF ALL IMPLIED WARRANTIES, INCLUDING WARRANTIES OF MERCHANTABILITY, FITNESS FOR A PARTICULAR PURPOSE, PERFORMANCE, OR OTHERWISE, WHICH ARE HEREBY EXCLUDED. IN NO EVENT SHALL THE COMPANY BE LIABLE FOR ANY DAMAGES, WHETHER DIRECT, INDIRECT, INCIDENTAL, FORSEEABLE, CONSEQUENTIAL, OR SPECIAL ARISING OUT OF OR IN CONNECTION WITH THIS PRODUCT INCLUDING DAMAGES ARISING FOR FOOD OR BEVERAGE SPOILAGE CLAIMS.**

You may have other legal rights depending upon where you live. Some States or Provinces do not allow limitations on warranties so the foregoing may not apply to you.

WARRANTY EXCLUSIONS

IMPROPER ELECTRICAL CONNECTIONS:

The Company is not responsible for the repair or replacement of failed or damaged components resulting from electrical power failure, the use of extension cords, low voltage, or voltage spikes to the Product.

IMPROPER USAGE:

This Limited Warranty does not cover failure or other damages to the Product resulting from (i) improper usage or installation or failure to clean and/or maintain the Product as set forth in the Owner's Manual; or (ii) accident, misuse, abuse, negligence, or modification or alteration of the Product.

CONSUMABLES:

This Limited Warranty does not include consumables or wear-and-tear items such as legs, feet, plastic component parts, splash shields, filters, gaskets, and non-stick cooking surfaces.

ADJUSTMENTS & CALIBRATIONS:

Leveling, tightening of fasteners, or utility connections normally associated with the original installation are the responsibility of the dealer, installer, or the end user and not the responsibility of the Company and will not be considered warranty issues.

If you think the Product has failed, or requires service, within its warranty period, please contact the Company's Customer Care Department through our website at: www.admiralcraft.com "Service" --> "Technical Support Request". A receipt proving the original purchase date will be required for all warranty claims, handwritten receipts are not accepted. You may also be required to return the Product for inspection and evaluation. Return shipping costs are not refundable. The Company is not responsible for returns lost in transit.

This Limited Warranty is Valid only in the USA and Canada.