



## Product Technical Specifications & Design guide

**Product Name:** IMQ8F4 module

---

**Author:** Wistron NeWeb Corporation

---

**Revision:** 1.0

---

**Revision Date:** 2026/01/15

## Contact Information

Technical Support website	<a href="https://SupportIoT.wnc.com.tw">https://SupportIoT.wnc.com.tw</a>
Company Website	<a href="http://www.wnc.com.tw">www.wnc.com.tw</a>

## Revision History

Rev. #	Author	Summary of Changes	Date
1.0	WNC	First release	2026/01/15
1.1	WNC	Modify module's picture	2026/04/23

### © WNC Corporation

THIS DOCUMENT AND THE INFORMATION CONTAINED HEREIN IS PROPRIETARY AND IS THE EXCLUSIVE PROPERTY OF WNC AND SHALL NOT BE DISTRIBUTED, REPRODUCED, OR DISCLOSED IN WHOLE OR IN PART WITHOUT PRIOR WRITTEN PERMISSION FROM WNC.

### LIMITATION OF LIABILITY

THIS DOCUMENT AND THE INFORMATION CONTAINED HEREIN IS PURELY FOR DESIGN REFERENCE AND SUBJECT TO REVISION BY WNC AT ANY TIME. NOTHING IN THIS DOCUMENT SHALL BE CONSTRUED AS GRANTING ANY WARRANTY OR RIGHT TO USE THE MATERIAL CONTAINED HEREIN WITHOUT WNC'S PRIOR EXPRESS WRITTEN CONSENT. WNC SHALL NOT BE LIABLE FOR ANY USE, APPLICATION OR DEVELOPMENT DERIVED FROM THE MATERIAL WITHOUT SUCH PRIOR EXPRESS WRITTEN CONSENT.

# Contents

- Contact Information ..... 2**
- Revision History ..... 2**
- Contents ..... 3**
- 1. Introduction..... 6**
  - 1.1. Abbreviation ..... 6
  - 1.2. Features ..... 7
- 2. Electrical Specifications ..... 9**
  - 2.1. Host interface pin assignments ..... 9
    - 2.1.1. LGA Pad Diagram ..... 9
    - 2.1.2. Pin Assignments..... 10
  - 2.2. Power supply ..... 19
  - 2.3. USB interface ..... 20
  - 2.4. SGMII interface ..... 22
  - 2.5. UIM interface..... 23
  - 2.6. Control interface..... 27
    - 2.6.1. Power-on Signal ..... 27
    - 2.6.2. Wake-up interface ..... 28
    - 2.6.3. Reset Signal..... 29
    - 2.6.4. WWAN state Signal..... 30
    - 2.6.5. Emergency download interface..... 30
  - 2.7. Digital interface ..... 31
    - 2.7.1. JTAG Interface..... 31
    - 2.7.2. SPI Master Interface ..... 32



- 2.7.3. PCM Interface ..... 32
- 2.7.4. I2S Interface..... 34
- 2.7.5. I2C Interface ..... 36
- 2.7.6. UART Interface..... 36
- 2.7.7. ADC Interface..... 37
- 2.7.8. Secure digital interfaces ..... 37
- 3. RF Specifications ..... 39**
  - 3.1. RF connections..... 39
  - 3.2. Interference and sensitivity ..... 40
  - 3.3. GNSS external circuit design..... 42
  - 3.4. RF Specification..... 44
    - 3.4.1 Band support ..... 44
    - 3.4.2 Bandwidth support..... 45
    - 3.4.3 RF Transmit Specification ..... 45
    - 3.4.4 RF Receiver Specification..... 46
    - 3.4.5 GNSS Receiver Specification ..... 50
- 4. Power ..... 51**
  - 4.1. Power consumption..... 51
- 5. Software Interface ..... 53**
  - 5.1. Support tools ..... 53
  - 5.2. USB interface ..... 53
- 6. Mechanical and Environmental Certifications ..... 54**
  - 6.1. PCBA Form Factor ..... 54
  - 6.2. Module orientation ..... 57
  - 6.3. Reflow..... 58



- 6.4. PCB pad design ..... 59
- 6.5. Labeling..... 60
- 6.6. SMT Voids control..... 61
  - 6.6.1. Mother board PCB thickness ..... 61
  - 6.6.2. Stencil design ..... 61
- 6.7. Thermal considerations ..... 62
- 7. Regulatory Compliance and Certification ..... 63**
  - 7.1. Certification testing ..... 63
- 8. Packaging ..... 64**
  - 8.1. Tape-and-Reel Package ..... 64
  - 8.2. Single Packaging for Samples..... 66
  - 8.3. MSL level..... 66
- 9. Safety Recommendation ..... 67**
- 10. Warning..... 68**



# 1. Introduction

The IMQ8F4 modules are LTE modems which incorporate an application CPU subsystem and peripheral interfaces and functions uniquely designed to address the power/performance/cost requirements of IoT and M2M applications. The CPU is based on Qualcomm's MDM architecture which offers OFDMA-related software based signal processing capabilities that significantly exceed traditional communications ARM cores. IMQ8F4 modules provide a variety of interfaces including USB 2.0, SGMII, SPI, UART, PCM, I2C, UIM & SDIO.

## 1.1. Abbreviation

Table 1. Abbreviation

Abbreviation	Definition
AC	Alternating Current
DC	Direct Current
ETSI	European Telecommunications Standards Institute
GND	Ground
GPS	Global Positioning System
GNSS	Any single or combined satellite navigation system (GPS, GLONASS and combined GPS/GLONASS)
GPIO	General Purpose Input Output
I/O	Input/Output
IoT	Internet of Things
I2C	Inter-Integrated Circuit
LGA	Land Grid Array
LTE	Long Term Evolution
Mbps	Megabits per second
MIPS	Millions of Instructions Per Second
N/A	Not/Applicable
OS	Operating System
PC	Personal Computer
PCM	Pulse Code Modulation

<b>PIN</b>	Personal Identification Number
<b>SIM</b>	Subscriber Identity Module
<b>SMA</b>	Surface Mount Antenna
<b>SPI</b>	Serial Peripheral Interface
<b>UART</b>	Universal Asynchronous Receiver-Transmitter
<b>UIM</b>	User Identity Module
<b>USB</b>	Universal Serial Bus
<b>Vref</b>	Voltage reference
<b>WCDMA</b>	Wideband Code Division Multiple Access
<b>WNC</b>	WNC Corporation

## 1.2. Features

This section lists main features of IMQ8F4 module support. For wireless technology and band support information among different modules, please refer to table2 for detail information.

Table 2. IMQ8F4 Series module overview

Module	Category	LTE	WCDMA	GNSS	Temperature Grade
		B2/4/5/12/13/25/26/66/71	B2/5		
IMQ8QF4	4	√	√	√	Industrial

Note: 1.Refer to section6.6 for more information about industrial grade.

2.“√” indicates supporting. “×” indicates not supporting.



**Feature list:**

- LTE 3GPP release 10 without Carrier Aggregation
- IMQ8F4: 3GPP, LTE Cat. 4 with 150/50 Mbps for DL/UL
- Supports LTE B2/4/5/12/13/25/26/66/71
- Supports WCDMA B2/5, 3GPP release 8
- Ultra-high-performance Cortex A7 microprocessor
- Modem subsystem (MSS)
- Resource and power management (RPM) subsystem
- Optimized for M2M and IoT markets
- Interfaces
  - HS USB 2.0 with integrated PHY
  - SGMII interface
  - Dual UART interfaces (4 bit and 2 bit) for data transfer and diagnostic tools
  - SDC1/First SPI interface
  - I2C/Second SPI interface
  - USIM interface
  - GPIOs
  - ADC
  - PCM/I2S
  - JTAG interface

## 2. Electrical Specifications

### 2.1. Host interface pin assignments

#### 2.1.1. LGA Pad Diagram

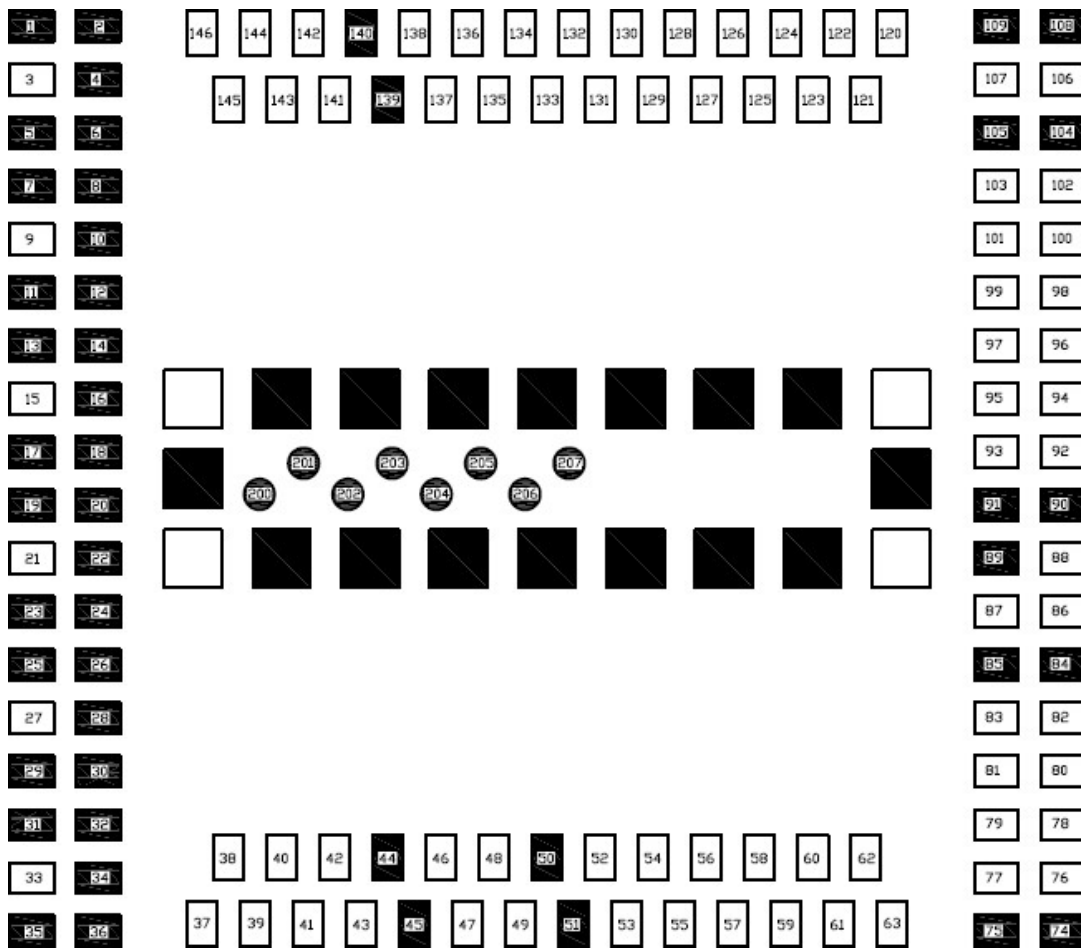

Figure 1. LGA pad diagram (top view)

2.1.2. Pin Assignments

I/O type description:

- AO : Analog Output
- AI : Analog Input
- DO : Digital Output
- DI : Digital Input

Table 3. Pin interface family

Interface Family	Signal	Description	I/O
<b>RF Interfaces</b>			
	RF_2	Diversity antenna	AI
	RF_GNSS	Reserved for GNSS receiver	AI
	RF_1	Main Antenna	AI/AO
<b>User Identity Module</b>			
	UIM_VCC	Power source for UIM	AO
	UIM_DATA	Data in/out	DI/DO
	UIM_CLK	Clock signal	DO
	UIM_RESET	Reset signal	DO
	UIM_DETECT	UIM Detect signal	DI/DO
<b>Data Interfaces- USB 2.0</b>			
	USB_HS_DP	USB Data Positive	DI/DO
	USB Detect	USB Detect	DI
	USB_HS_DM	USB Data Negative	DI/DO
<b>Data Interfaces- SGMII</b>			
	SGMII_RX_P	SGMII receive - plus	DI
	SGMII_RX_M	SGMII receive - minus	DI
	SGMII_TX_P	SGMII transmit - plus	DO
	SGMII_TX_M	SGMII transmit - minus	DO
	SGMII_MDIO	SGMII Management data	DI/DO
	SGMII_MDC	SGMII Management data clock	DI/DO
<b>Data Interfaces- UART1</b>			
	UART1_CTS_N	Clear To Send for UART 1	DI
	UART1_RFR_N	Ready for receive for UART1	DO
	UART1_RX	Receive for UART 1	DI
	UART1_TX	Transmit for UART 1	DO
<b>Data Interfaces- UART2</b>			



UART2_RX	Receive for UART 2	DI
UART2_TX	Transmit for UART 2	DO
<b>Data Interfaces- I2C/2nd_SPI</b>		
I2C_SDA	Data in/out	DI/DO
2nd_SPI_EN_1	2nd_SPI chip select	DO
I2C_SCL	Clock signal	DO
2nd_SPI_CLK	2nd_SPI serial clock	DO
SPI_MOSI	2nd_SPI master out slave in	DO
NC	NC	-
SPI_MISO	2nd_SPI master in slave out	DI
<b>Data Interfaces- SDC1/1st_SPI</b>		
SDC1_DATA_3	SDC1_DATA_3	DI/DO
1st_SPIM_MOSI	1st_SPI master out slave in	DO
SDC1_DATA_2	SDC1_DATA_2	DI/DO
1st_SPIM_MISO	1st_SPI master in slave out	DI
SDC1_DATA_1	SDC1_DATA_1	DI/DO
1st_SPIM_EN_1	1st_SPI chip select	DO
SDC1_DATA_0	SDC1_DATA_0	DI/DO
1st_SPIM_CLK	1st_SPI serial clock	DO
SDC1_CMD	SDC1_CMD	DI/DO
SDC1_CLK	SDC1_CLK	DO
<b>Module Control and State Interfaces</b>		
WWAN_STATE	Wireless WAN Radio State	DO
POWER_ON	Power On the module	DI
WAKEUP_OUT	Module wakes up host	DO
WAKEUP_IN	Host wakes up module	DI
RESET	Reset the module	DI
<b>Power and Ground</b>		
VREF	Voltage Reference Output	AO
VCC	Main Power	AI
GND	GND	AI
<b>General Purpose</b>		
GPIO	Digital I/O	DI/DO
ADC_CONVENTOR	ADC_CONVENTOR	AI
<b>AUDIO- PCM/I2S</b>		
PCM_DIN	PCM_DIN	DI

	I2S_DATA0	I2S_DATA0	DI/DO
	PCM_DOUT	PCM_DOUT	DO
	I2S_DATA1	I2S_DATA1	DI/DO
	PCM_CLK	PCM_CLK	DO
	I2S_SCK	I2S_SCK	DO
	PCM_SYNC	PCM_SYNC	DO
	I2S_WS	I2S_WS	DO
<b>RFU- RFU</b>			
	RFU	Reserved For Future Use	-
<b>Debug- JTAG</b>			
	JTAG_SRST_N	JTAG reset for debug	DI
	JTAG_TCK	JTAG clock input	DI
	JTAG_TDI	JTAG data input	DI
	JTAG_TDO	JTAG data output	DO
	JTAG_TMS	JTAG mode select input	DI
	JTAG_TRST_N	JTAG reset	DO
	PS_HOLD	PS_HOLD	DI
<b>Debug- Force_USB_BOOT</b>			
	Force_USB_BOOT_CONFIG	Force USB BOOT CONFIG	DI

Table 4. Pin Assignments

Pin No.	Modem mode	Host Mode	Voltage Level (V)		
			Min.	Typ.	Max.
1	GND	GND	-	0	-
2	GND	GND	-	0	-
3	NC	NC	-	-	-
4	GND	GND	-	0	-
5	GND	GND	-	0	-
6	GND	GND	-	0	-
7	GND	GND	-	0	-
8	GND	GND	-	0	-
9	RF_GNSS	RF_GNSS	-	-	-
10	GND	GND	-	0	-
11	GND	GND	-	0	-
12	GND	GND	-	0	-
13	GND	GND	-	0	-



14	GND	GND	-	0	-
15	RF_1	RF_1	-	-	-
16	GND	GND	-	0	-
17	GND	GND	-	0	-
18	GND	GND	-	0	-
19	GND	GND	-	0	-
20	GND	GND	-	0	-
21	RF_2	RF_2	-	-	-
22	GND	GND	-	0	-
23	GND	GND	-	0	-
24	GND	GND	-	0	-
25	GND	GND	-	0	-
26	GND	GND	-	0	-
27	NC	NC	-	-	-
28	GND	GND	-	0	-
29	GND	GND	-	0	-
30	GND	GND	-	0	-
31	GND	GND	-	0	-
32	GND	GND	-	0	-
33	NC	NC	-	-	-
34	GND	GND	-	0	-
35	GND	GND	-	0	-
36	GND	GND	-	0	-
37	VCC1	VCC1	3.3	3.8	4.2
38	VCC2	VCC2	3.3	3.8	4.2
39	VCC3	VCC3	3.3	3.8	4.2
40	VCC4	VCC4	3.3	3.8	4.2
41	VCC5	VCC5	3.3	3.8	4.2
42	VCC6	VCC6	3.3	3.8	4.2
43	NC	NC	-	-	-
44	GND	GND	-	0	-
45	GND	GND	-	0	-
46	PCM_SYNC/GPIO46	PCM_SYNC/GPIO46	1.7	1.8	1.9
47	PCM_DIN/GPIO47	PCM_DIN/GPIO47	1.7	1.8	1.9
48	PCM_DOUT/GPIO48	PCM_DOUT/GPIO48	1.7	1.8	1.9
49	PCM_CLK/GPIO49	PCM_CLK/GPIO49	1.7	1.8	1.9

50	GND	GND	-	0	-
51	GND	GND	-	0	-
52	GPIO01/Force USB BOOT Config*4	GPIO01/Force USB BOOT Config*4	1.7	1.8	1.9
53	GPIO02	GPIO02	1.7	1.8	1.9
54	GPIO03	GPIO03	1.7	1.8	1.9
55	GPIO04	GPIO04	1.7	1.8	1.9
56	NC	SGMII_TX_P*1	-	-	-
57	NC	SGMII_TX_M*1	-	-	-
58	NC	SGMII_RX_P*1	-	-	-
59	NC	SGMII_RX_M*1	-	-	-
60	I2C_SDA	I2C_SDA/ 2nd_SPI_EN_1	1.7	1.8	1.9
61	I2C_SCL	I2C_SCL/ 2nd_SPI_CLK	1.7	1.8	1.9
62	NC	2nd_SPI_MOSI	1.7	1.8	1.9
63	NC	2nd_SPI_MISO	1.7	1.8	1.9
74	GND	GND	-	0	-
75	GND	GND	-	0	-
76	RFFE1_DATA	RFFE1_DATA	-	-	-
77	RFFE1_CLK	RFFE1_CLK	-	-	-
78	NC	NC	-	-	-
79	NC	NC	-	-	-
80	UART1_CTS (UART 1)	UART1_CTS (UART 1)	1.7	1.8	1.9
81	UART1_RTS (UART 1)	UART1_RTS (UART 1)	1.7	1.8	1.9
82	UART1_RX (UART 1)	UART1_RX (UART 1)	1.7	1.8	1.9
83	UART1_TX (UART 1)	UART1_TX (UART 1)	1.7	1.8	1.9
84	GND	GND	-	0	-
85	GND	GND	-	0	-
86	USB_Dp*2	USB_Dp*2	-	-	-
87	USB Detect*3	USB Detect*3	1.7	1.8	1.9
88	USB_Dn*2	USB_Dn*2	-	-	-
89	GND	GND	-	0	-
90	GND	GND	-	0	-
91	GND	GND	-	0	-
92	NC	GPIO92	1.7	1.8	1.9



93	GPIO93	GPIO93	1.7	1.8	1.9
94	GPIO94	GPIO94	1.7	1.8	1.9
95	GPIO95	GPIO95	1.7	1.8	1.9
96	GPIO96	GPIO96	1.7	1.8	1.9
97	GPIO97	GPIO97	1.7	1.8	1.9
98	NC	GPIO98	1.7	1.8	1.9
99	NC	NC	-	-	-
100	NC	NC	-	-	-
101	NC	GPIO101	1.7	1.8	1.9
102	NC	GPIO102	1.7	1.8	1.9
103	NC	EPHY_RST_N	1.7	1.8	1.9
104	GND	GND	-	0	-
105	GND	GND	-	0	-
106	UART2_RX (UART 2)	UART2_RX (UART 2)	1.7	1.8	1.9
107	UART2_TX (UART 2)	UART2_TX (UART 2)	1.7	1.8	1.9
108	GND	GND	-	0	-
109	GND	GND	-	0	-
120	NC	SGMII_MDC*1	-	-	-
121	NC	SGMII_MDIO*1	-	-	-
122	AD Converter	AD Converter	0.1	-	1.7
123	NC	SDC1_CMD	1.7	1.8	1.9
124	NC	SDC1_CLK	1.7	1.8	1.9
125	1st_SPI_MOSI	SDC1_DATA_3/ 1st_SPIM_MOSI	1.7	1.8	1.9
126	1st_SPI_MISO	SDC1_DATA_2/ 1st_SPIM_MISO	1.7	1.8	1.9
127	1st_SPI_EN_1	SDC1_DATA_1/ 1st_SPIM_EN_1	1.7	1.8	1.9
128	1st_SPI_CLK	SDC1_DATA_0/ 1st_SPIM_CLK	1.7	1.8	1.9
129	GPIO05	GPIO05	1.7	1.8	1.9
130	GPIO06	GPIO06	1.7	1.8	1.9
131	GPIO07	GPIO07	1.7	1.8	1.9
132	GPIO08	EPHY_INT_N/GPIO08	1.7	1.8	1.9
133	UIM_VCC	UIM_VCC	1.7/2.7	1.8/3.0	1.9/3.3
134	UIM_DATA	UIM_DATA	1.7/2.7	1.8/3.0	1.9/3.3



135	UIM_CLK	UIM_CLK	1.7/2.7	1.8/3.0	1.9/3.3
136	UIM_RESET	UIM_RESET	1.7/2.7	1.8/3.0	1.9/3.3
137	UIM_DETECT	UIM_DETECT	1.7	1.8	1.9
138	NC	NC	-	-	-
139	GND	GND	-	0	-
140	GND	GND	-	0	-
141	WWAN_STATE	WWAN_STATE	1.7	1.8	1.9
142	POWER_ON	POWER_ON	1.7	1.8	1.9
143	WAKEUP_OUT*5	WAKEUP_OUT*5	1.7	1.8	1.9
144	WAKEUP_IN	WAKEUP_IN	1.7	1.8	1.9
145	RESET	RESET	1.7	1.8	1.9
146	VREF	VREF	1.7	1.8	1.9
200	JTAG_SRST_N	JTAG_SRST_N	1.7	1.8	1.9
201	JTAG TCK	JTAG TCK	1.7	1.8	1.9
202	JTAG TDI	JTAG TDI	1.7	1.8	1.9
203	JTAG TDO	JTAG TDO	1.7	1.8	1.9
204	JTAG_TMS	JTAG_TMS	1.7	1.8	1.9
205	JTAG TRST_N	JTAG TRST_N	1.7	1.8	1.9
206	PS_HOLD	PS_HOLD	1.7	1.8	1.9
207	NC	NC	-	-	-

## Notes:

- \*1. Refer to SGMII standard for more electronic characteristics.
- \*2. Refer to section 2.3, for more information please check USB2.0 standard
- \*3. Pull pin87 USB detect to VREF with a 100k resistor to enable module USB, pull pin87 low to disable module USB, CPU USB PHY consumes some current when USB is enabled.
- \*4. Do not pull pin52 to high before the system boot process is complete.
- \*5. Do not pull pin143 WAKEUP\_OUT to high; otherwise boot will fail.
- \*6. Leave unused pins floating
- \*7. Reserve test points on pin52/86/88/106/107 for debug purpose if possible.
- \*8. If voltage level of digital I/O from the other side is not compatible with module, level shifter is recommended to transfer the voltage level to 1.8V.

Table 5. Digital I/O characteristics

Parameter		Comments	Min	Max	Unit
V <sub>IH</sub>	High-level input voltage	CMOS/Schmitt	0.65 * V <sub>DD_Px</sub>	–	V
V <sub>IL</sub>	Low-level input voltage	CMOS/Schmitt	–	0.35 * V <sub>DD_Px</sub>	V
V <sub>OH</sub>	High-level output voltage	CMOS, at rated drive strength	V <sub>DD_Px</sub> - 0.45		V
V <sub>OL</sub>	Low-level output voltage	CMOS, at rated drive strength	–	0.45	V
R <sub>P</sub>	Pull resistance	Pullup and pulldown	55	390	kΩ
R <sub>K</sub>	Keeper resistance		30	150	kΩ
I <sub>IH</sub>	Input high leakage current	No pulldown	–	1	μA
I <sub>IL</sub>	Input low leakage current <sup>4</sup>	No pullup	-1	–	μA
V <sub>SHYS</sub>	Schmitt hysteresis voltage		100	–	mV
C <sub>I/O</sub>	I/O capacitance		–	5	pF

Below is the I/O default setting table to describe the level. It's recommended to follow the pulling High or Low to choose a suitable GPIO for application.

PU: Pull Up.

PD: Pull Down

NP: Non-Pull

Table 6. I/O default setting table

Pin No.	Signal Name	Type	Default setting in Normal mode
46	PCM_SYNC/GPIO46	DI /DO	PD
47	PCM_IN/GPIO47	DI /DO	PD
48	PCM_OUT/GPIO48	DI /DO	PD
49	PCM_CLK/GPIO49	DI /DO	PD
52	GPIO01	DI/DO	PD
53	GPIO02	DI/DO	PD
54	GPIO03	DI/DO	PD
55	GPIO04	DI/DO	PD
60	I2C_SCL/ 2nd_SPI_CLK	DI/DO	PD
61	I2C_SDA/ 2nd_SPI_EN_1	DI/DO	PD
62	2nd_SPI_MOSI	DI/DO	PD
63	2nd_SPI_MISO	DI/DO	PD



<b>80</b>	UART1_CTS (UART1)	DI/DO	PD
<b>81</b>	UART1_RTS (UART1)	DI/DO	PD
<b>82</b>	UART1_RX (UART1)	DI/DO	PD
<b>83</b>	UART1_TX (UART1)	DI/DO	PD
<b>92</b>	GPIO92	DI/DO	PD
<b>93</b>	GPIO93	DO	NP
<b>94</b>	GPIO94	DI/DO	PD
<b>95</b>	GPIO95	DI/DO	PD
<b>96</b>	GPIO96	DI/DO	PD
<b>97</b>	GPIO97	DI/DO	PD
<b>98</b>	GPIO98	DI/DO	PU
<b>101</b>	GPIO101	DI/DO	PD
<b>102</b>	GPIO102	DI/DO	PD
<b>103</b>	GPIO103	DI/DO	PD
<b>106</b>	UART2_RX (UART2)	DI/DO	PD
<b>107</b>	UART2_TX (UART2)	DI/DO	PD
<b>120</b>	GPIO120	DI/DO	PD
<b>123</b>	GPIO123	DI/DO	PD
<b>124</b>	GPIO124	DI/DO	NP
<b>125</b>	SPIM_MOSI	DI/DO	PD
<b>126</b>	SPIM_MISO	DI/DO	PD
<b>127</b>	SPIM_EN	DI/DO	PD
<b>128</b>	SPIM_CLK	DI/DO	PD
<b>129</b>	GPIO05	DI/DO	PD
<b>130</b>	GPIO06	DI/DO	PD
<b>131</b>	GPIO07	DI/DO	PU
<b>132</b>	GPIO08	DI/DO	PD
<b>141</b>	WWAN_STATE	DI/DO	PD
<b>143</b>	WAKEUP_OUT	DI/DO	PD

## 2.2. Power supply

LTE module power input is VCC. The internal power chipset will transfer VCC to other power level.

Table 7. Power supply voltage level

Power	Pin Name	Pads	Description	Voltage Level (V)		
				Min.	Typ.	Max.
VCC	VCC1 to VCC6	Nos. 37 to 42	Main Power Supply	3.3	3.8	4.2

The IMQ8F4 include an integrated power manager enabling single and direct voltage supply from the battery, reducing the overall bill of materials. The typical voltage 3.8V is recommended.

**Schematic suggestion:** Must to separate module power supply to three paths to keep power clean as below for TX spurious performance. The VPH\_PWR is for Baseband and RF transceiver, the VPH\_PWR\_RF is for RF PA, the VPH\_PWR\_RF\_VBATT is for RF PA control circuit.

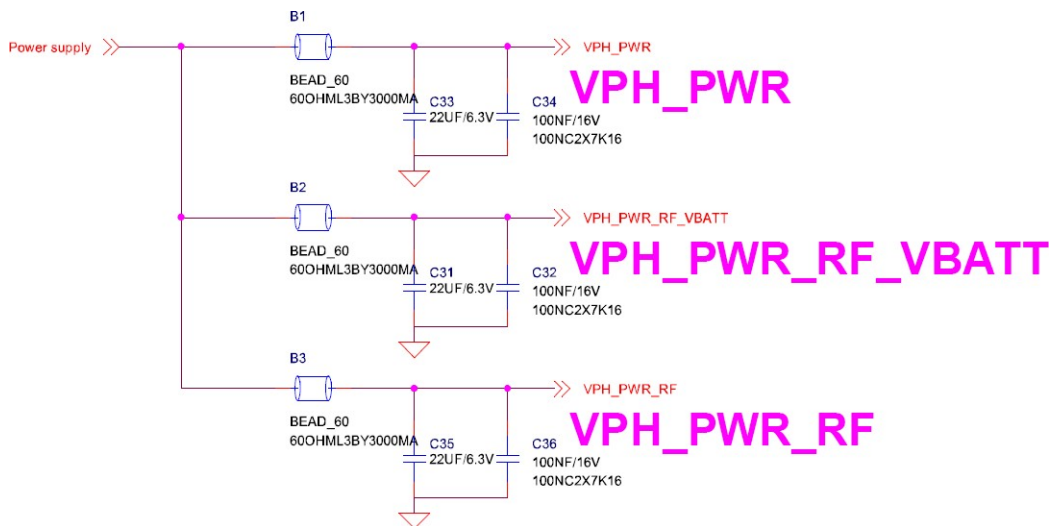

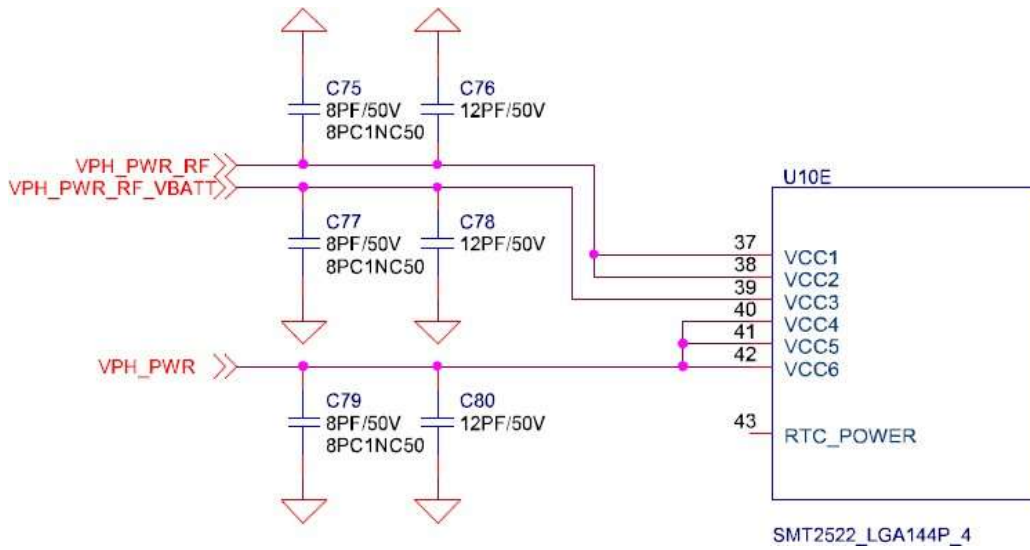

**Layout Suggestion:** The 22μF, 0.1uF, 12pF and 8pF capacitors are required to place near VCC pins as close as possible. Each power trace should possess sufficient line width to withstand its respective current listed in the table below:

Net Name	Current Value
VCC(1–2) total	2A
VCC(3) total	100mA
VCC(4–6) total	1A
UIM_VCC	150 mA
VREF	300 mA

### 2.3. USB interface

The IMQ8F4 modules comply with USB 2.0 high-speed protocol. The USB input/output lines follow USB 2.0 specifications.

Table 8. Signals of the USB interface

Name	Description	Input/Output (Direction to module)	Voltage Level (V)		
			Min.	Typ.	Max.
D+	USB data positive (low-/full-speed)	Input High	2	3.3	3.6



	Input Low	0		0.8
	Output High	2.8	3.3	3.6
	Output Low			0.3
USB data positive (high-speed)				
	Input High	0.3		0.44
	Input Low	0		0.01
	Output High	0.36	0.38	0.44
	Output Low	0		0.01
<b>D-</b>				
USB data negative (low-/full-speed)				
	Input High	2	3.3	3.6
	Input Low	0		0.8
	Output High	2.8	3.3	3.6
	Output Low			0.3
USB data negative (high-speed)				
	Input High	0.3		0.44
	Input Low	0		0.01
	Output High	0.36	0.38	0.44
	Output Low	0		0.01

The layout design of this circuit on the carrier board should comply with the USB 2.0 high-speed protocol.

**Layout suggestion:**

- Differential impedance: 90 Ω
- Space to other signals should be at least 20 mils
- Intra-lane length difference should be less than 150 mils
- Maximum length for each trace:150 mm

Signals lengths on modules are tuned as below:

Function	Net	Length (mil)
<b>USB</b>		
	USB_Dp	545.54
	USB_Dn	503.04



## 2.4. SGMII interface

The IMQ8F4 modules integrate Ethernet MAC with SGMII interfaces with the following key features:

- IEEE 802.3 compliance
- Full duplex at 1 Gbps
- Half/full duplex for 10/100 Mbps
- Supports VLAN tagging
- Supports IEEE 1588, Precision Time Protocol (PTP)
- Can be used to connect to external Ethernet PHYs such as AR8033 or to an external switch

The following figure illustrates an example of the additional logic connection between the modules and the Ethernet chip. Refer to ENG-46158, Rev 1.8 for electrical and timing specifications.

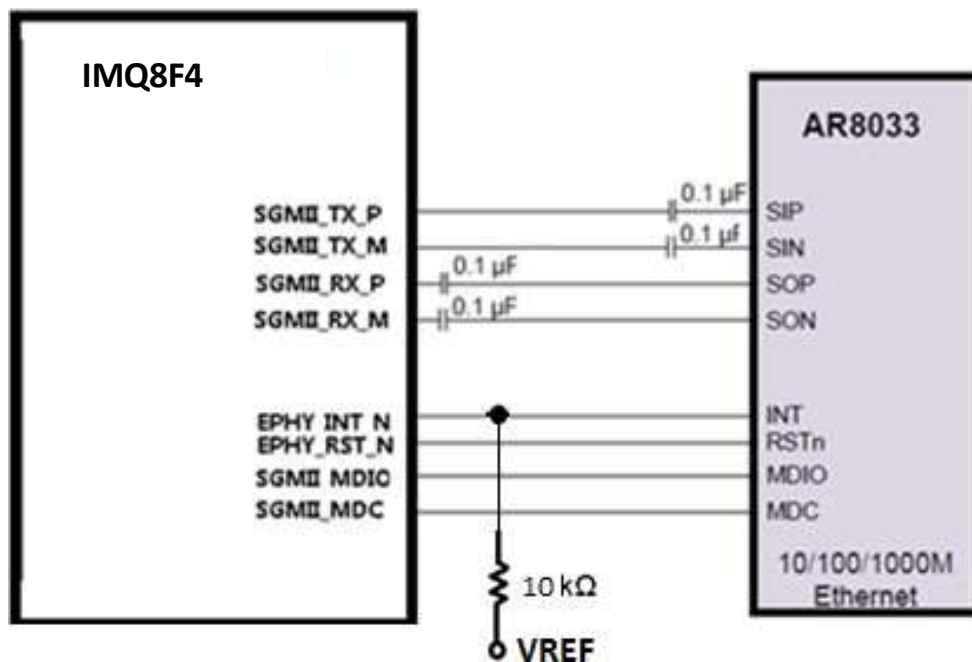

Figure 2. SGMII circuit example

### Layout suggestion:

- Differential impedance: 100 Ω
- Space to other signals: > 3x line width
- Lane-to-lane space: > 3x line width
- Intra-lane mismatch: < 0.7 mm

Signal lengths on the modules are tuned as below:

Function	Net	Length (mil)
<b>SGMII</b>		
	SGMII_TX_P	617.11
	SGMII_TX_M	642.13
	SGMII_RX_P_C+SGMII_RX_P	661.40
	SGMII_RX_M_C+SGMII_RX_M	675.06

## 2.5. UIM interface

IMQ8F4 modules provide an UIM\_DETECT input pin for UIM connector to detect UIM card. When UIM card is present, UIM\_DETECT should be high (1.8V). If UIM card is absent, UIM\_DETECT should be low. It's required to pull UIM\_DETECT to VREF with a 470k resistor. A 0.1 $\mu$ F and a 33pF capacitor are recommended to place between UIM\_VCC and Ground in parallel. A 33pF capacitor is recommended to place between UIM\_RESET, UIM\_CLK and UIM\_DATA and Ground in parallel, see Figure5 for reference.

Electrostatic discharge (ESD) protection circuit is also recommended to place near the UIM socket as close as possible, and the Ground pin of the ESD protection component must be well connected to the Ground plane.

The following figure shows an example of UIM card circuit.

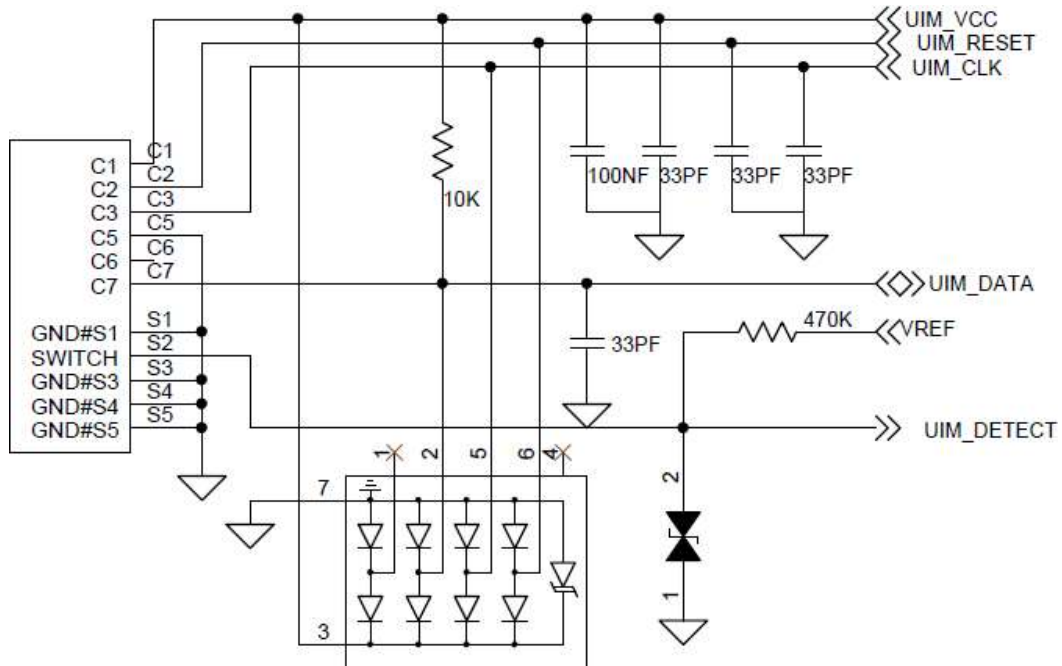

Figure 3. UIM card circuit example

It's highly suggested to make sure that SIM electrical characteristics can meet ETSI TS 102 221 requirement before going to certification like PTCRB. Refer to the following capture from ETSI TS 102 221 section 5 for critical requirement:

## 5.2 Class B operating conditions

### 5.2.1 Supply voltage Vcc (contact C1)

The terminal shall operate the UICC within the following limits.

Table 5.5: Electrical characteristics of Vcc under normal operating conditions

Symbol	Minimum	Maximum	Unit
Vcc	2,7	3,3	V

### 5.2.2 Reset (RST) (contact C2)

The terminal shall operate the UICC within the following limits.

**Table 5.6: Electrical characteristics of RESET (RST) under normal operating conditions**

Symbol	Conditions	Minimum	Maximum	Unit
$V_{OH}$	$I_{OHmax} = +20 \mu A$	$0,8 \times V_{CC}$	$V_{CC}$ (see note)	V
$V_{OL}$	$I_{OLmax} = -200 \mu A$	0 (see note)	$0,2 \times V_{CC}$	V
$t_R t_F$	$C_{in} = C_{out} = 30 pF$		400	$\mu s$

NOTE: To allow for overshoot the voltage on RST should remain between -0,3 V and  $V_{CC} + 0,3 V$  during dynamic operations.

### 5.2.3 Clock CLK (contact C3)

The terminal shall support 1 MHz to 5 MHz. The terminal shall supply the clock. When only the interface specified in the present document is activated, no "internal clock" shall be used in the UICC.

The duty cycle shall be between 40 % and 60 % of the period during stable operation.

The terminal shall operate the UICC within the following limits.

**Table 5.7: Electrical characteristics of Clock (CLK) under normal operating conditions**

Symbol	Conditions	Minimum	Maximum	Unit
$V_{OH}$	$I_{OHmax} = +20 \mu A$	$0,7 \times V_{CC}$	$V_{CC}$ (see note)	V
$V_{OL}$	$I_{OLmax} = -20 \mu A$	0 (see note)	$0,2 \times V_{CC}$	V
$t_R t_F$	$C_{in} = C_{out} = 30 pF$		50	ns

NOTE: To allow for overshoot the voltage on CLK should remain between -0,3 V and  $V_{CC} + 0,3 V$  during dynamic operations.

### 5.2.4 I/O (contact C7)

Table 5.8 defines the electrical characteristics of the I/O (contact C7). The values given in the table allow the derivation of the values of the pull-up resistor in the terminal and the impedance of the drivers and receivers in the terminal and UICC.

**Table 5.8: Electrical characteristics of I/O under normal operating conditions**

Symbol	Conditions	Minimum	Maximum	Unit
$V_{IH}$	$I_{IHmax} = \pm 20 \mu A$ (see note 2)	$0,7 \times V_{CC}$	$V_{CC} + 0,3$	V
$V_{IL}$	$I_{ILmax} = +1 mA$	-0,3	$0,2 \times V_{CC}$	V
$V_{OH}$ (see note 1)	$I_{OHmax} = +20 \mu A$	$0,7 \times V_{CC}$	$V_{CC}$ (see note 3)	V
$V_{OL}$	$I_{OLmax} = -1mA$	0 (see note 3)	0,4	V
$t_R t_F$	$C_{in} = C_{out} = 30 pF$		1 100 (see note 4)	$\mu s$ ns

NOTE 1: It is assumed that a pull-up resistor is used on the interface device (recommended value: 20 k $\Omega$ ).

NOTE 2: During static conditions (idle state) only the positive value can apply. Under dynamic operating conditions (transmissions) short-term voltage spikes on the I/O line may cause a current reversal.

NOTE 3: To allow for overshoot the voltage on I/O shall remain between -0,3 V and  $V_{CC} + 0,3 V$  during dynamic operation.

NOTE 4: This value applies when the low impedance buffer is selected.

### 5.3 Class C operating conditions

#### 5.3.1 Supply voltage Vcc (contact C1)

The terminal shall operate the UICC within the following limits.

**Table 5.9: Electrical characteristics of Vcc under normal operating conditions**

Symbol	Minimum	Maximum	Unit
Vcc	1,62	1,98	V

#### 5.3.2 Reset (RST) (contact C2)

The terminal shall operate the UICC within the following limits.

**Table 5.10: Electrical characteristics of RESET (RST) under normal operating conditions**

Symbol	Conditions	Minimum	Maximum	Unit
V <sub>OH</sub>	I <sub>OHmax</sub> = +20 µA	0,8 x Vcc	Vcc (see note)	V
V <sub>OL</sub>	I <sub>OLmax</sub> = -200 µA	0 (see note)	0,2 x Vcc	V
t <sub>R</sub> t <sub>F</sub>	C <sub>in</sub> = C <sub>out</sub> = 30 pF		400	µs

NOTE: To allow for overshoot the voltage on RST should remain between -0,3 V and Vcc + 0,3 V during dynamic operations.

#### 5.3.3 Clock CLK (contact C3)

**Table 5.11: Electrical characteristics of Clock (CLK) under normal operating conditions**

Symbol	Conditions	Minimum	Maximum	Unit
V <sub>OH</sub>	I <sub>OHmax</sub> = +20 µA	0,7 x Vcc	Vcc (see note)	V
V <sub>OL</sub>	I <sub>OLmax</sub> = -20 µA	0 (see note)	0,2 x Vcc	V
t <sub>R</sub> t <sub>F</sub>	C <sub>in</sub> = C <sub>out</sub> = 30 pF		50	ns

NOTE: To allow for overshoot the voltage on CLK should remain between -0,3 V and Vcc + 0,3 V during dynamic operations.

### 5.3.4 I/O (contact C7)

Table 5.12 defines the electrical characteristics of the I/O (contact C7). The values given in the table allow the derivation of the values of the pull-up resistor in the terminal and the impedance of the drivers and receivers in the terminal and UICC.

**Table 5.12: Electrical characteristics of I/O under normal operating conditions**

Symbol	Conditions	Minimum	Maximum	Unit
$V_{IH}$	$I_{IHmax} = \pm 20 \mu A$ (see note 2)	$0,7 \times V_{CC}$	$V_{CC} + 0,3$	V
$V_{IL}$	$I_{ILmax} = +1 \text{ mA}$	-0,3	$0,2 \times V_{CC}$	V
$V_{OH}$ (see note 1)	$I_{OHmax} = +20 \mu A$	$0,7 \times V_{CC}$	$V_{CC}$ (see note 3)	V
$V_{OL}$	$I_{OLmax} = -1 \text{ mA}$	0 (see note 3)	0,3	V
$t_R$ $t_F$	$C_{in} = C_{out} = 30 \text{ pF}$		1 100 (see note 4)	$\mu s$ ns

NOTE 1: It is assumed that a pull-up resistor is used on the interface device (recommended value: 20 k $\Omega$ ).

NOTE 2: During static conditions (idle state) only the positive value can apply. Under dynamic operating conditions (transmissions) short-term voltage spikes on the I/O line may cause a current reversal.

NOTE 3: To allow for overshoot the voltage on I/O shall remain between -0,3 V and  $V_{CC} + 0,3$  V during dynamic operation.

NOTE 4: This value applies when the low impedance buffer is selected.

## 2.6. Control interface

This section describes the power-on/off, wake-up and reset interface on how to control the module.

### 2.6.1. Power-on Signal

The POWER\_ON is an active Low input signal used to enable or disable the module. Do not toggle the PERST# pin during power-on. This signal has the highest priority over the wakeup, the alarms signals, and the digital control pins.

There are three possible states of the module:

- Module Power Off - VCC is not present.
- Module Disabled - VCC is supplied, pull power-on signal be high.
- Module Enabled - VCC is supplied, pull power-on signal be low to bootup.

The state transitions are defined as follows:

- When voltage is applied to VCC, the module shall enter the Module Disabled state.

- An input to the POWER\_ON pin shall trigger the transition from the Module Disabled to the Module Enabled state. See figure6, a low pulse( $t_{low} > 0s$ ) on POWER\_ON pad will enable the module after VCC is applied.
- An input to the POWER\_ON pin shall trigger the transition from the Module Enabled to the Module Disabled state. See figure6, after power on, a low pulse ( $t_{low} > 2s$ ) on POWER\_ON pin will disable (power-off) the module.

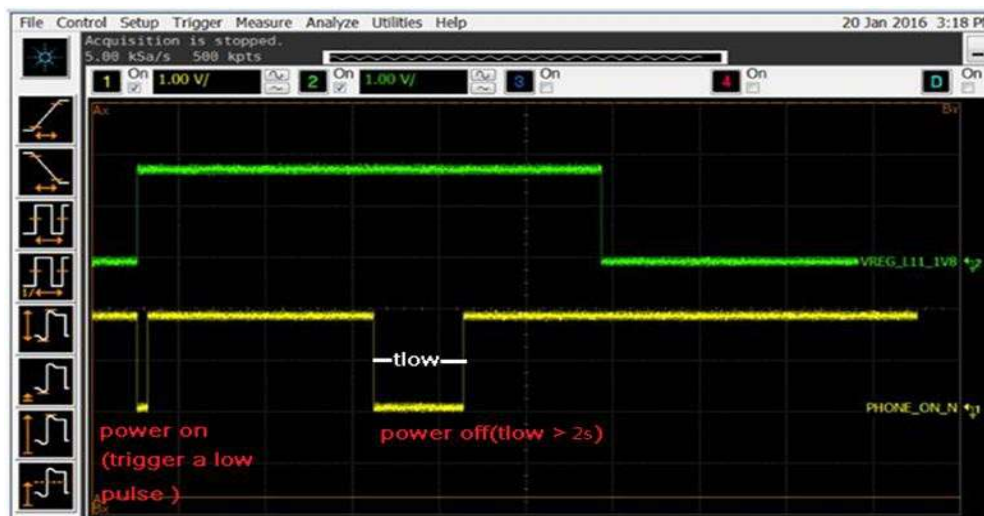

Figure 4. Power ON/OFF timing

### 2.6.2. Wake-up interface

In applications where power consumption is a major factor in performance metrics (such as battery-operated sensors that are based on IOT/M2M modem solution and also include a third party host), it is necessary to define a simple interface that will allow both the modem and the host to be able to enter low power states whenever possible and the other side to wake it up once required.

For example, if the host has no data to transmit or any other tasks, it may enter some low power state according to its own capabilities and configurations. If during that period the host is in a low power state and the modem suddenly receives data, it must wake-up the host.

A similar requirement exists from the other side. For example, if the modem is in a low power state and suddenly the host must transmit data, it must be able to wake-up the modem.

The interface consists of two signals: One is driven by the host and received by the modem; the other is driven by the modem and received by the host.

Each side can wake the other side by toggling wakeup signal high and allowing the other side to go to sleep when not needed by toggling it low.

- “WAKEUP\_IN” (Host: Output, Modem: Input):
  - LOW: SoC does not require the MODEM (allowing it to sleep).
  - HIGH: SoC requires the MODEM or acknowledges it is ready following a wakeup request from the MODEM.
- “WAKEUP\_OUT” (Host: Input, Modem: Output):
  - LOW: The MODEM does not require the Host (allowing it to sleep)
  - HIGH: The MODEM requires the Host or acknowledges it is ready following a wakeup request from the SoC.

When IMQ8F4 modules act as modem, keep WAKEUP\_IN high before system boot process is complete, after system boot, keep WAKEUP\_IN low. WAKEUP\_IN and WAKEUP\_OUT behavior of host mode will be discussed according to product specification.

### 2.6.3. Reset Signal

The Reset Signal is a hardware reset signal to control the system reset directly. You can connect it to a key or a control signal. A low pulse (3s<tlow<8s) after power on will reset the module, see figure7.

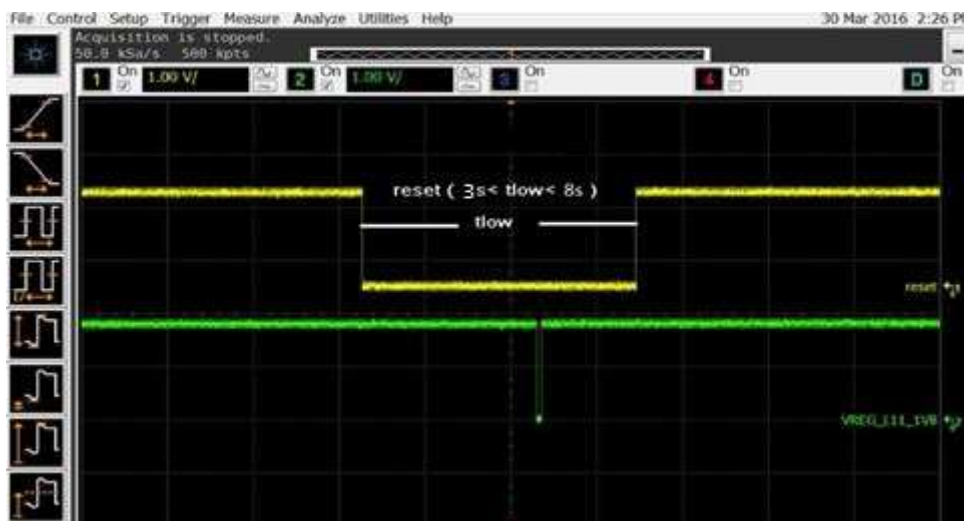

Figure 5. Reset Signals circuit

#### 2.6.4. WWAN state Signal

The WWAN state pin definition as below.

- WWAN state pin output “high”  
When device register to network, the WWAN state pin output “high”.
- WWAN state pin output “low”  
When device not to register to network, the WWAN state pin output “low”.

#### 2.6.5. Emergency download interface

Two ways can enter emergency download, hardware and software path.

- Hardware path to enter EDL:
  - Pull Force\_USB\_BOOT (pin52) to VREF (pin146) until power on module and pull low power-on signal. Success if device manager shows QDLoader 9008.

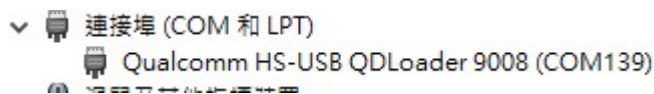

- Send Reboot once complete firmware download.
- Exit emergency download by power cycling VCC on module.

- Software path to enter EDL:

Module bootup completely, check interfaces are generated.

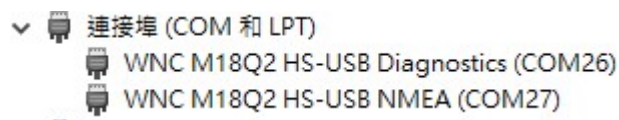

Follow software flow by WNC document- Build & download open source FW SOP .  
Success if device manager shows QDLoader 9008.

### Download image

1. Connect the device.
2. Execute "adb root" command in cmd.
3. Execute "adb reboot edl" command in cmd.
4. Copy the OUTPUT\_IMAGE\_4K to the windows system.
5. Double-click on the "download\_4k.bat" file.  
The console will disappear once all the images have been downloaded.
6. Reboot

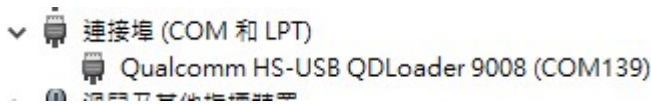

## 2.7. Digital interface

This section provides required AC timing information related to module digital interfaces.

### 2.7.1. JTAG Interface

IMQ8F4 provide one JTAG interface, leave JTAG pins floating if not used.

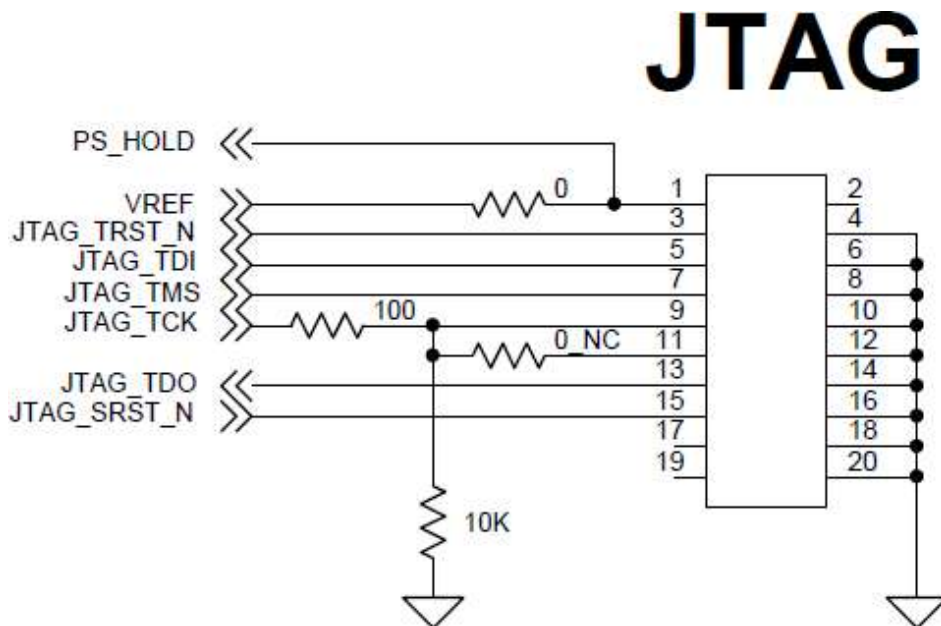
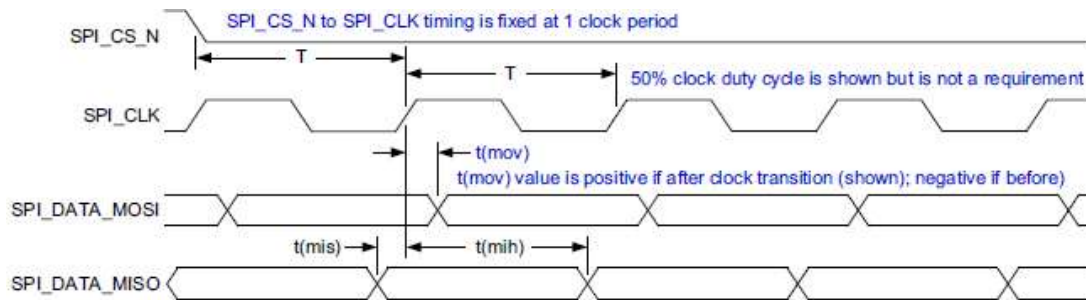

Figure 6. JTAG schematic (example)

### 2.7.2. SPI Master Interface

- SPIM\_CLK – Output clock
- SPIM\_CS – Output, chip-select
- SPIM\_MOSI – Output, data to slave
- SPIM\_MISO – Input, data from slave

#### Timing



Parameter	Comments	Min	Typ	Max	Unit
$T$ <sup>1</sup>	SPI clock period: 50 MHz max	20.0	–	–	ns
$t(ch)$	Clock high	9.0	–	–	ns
$t(cl)$	Clock low	9.0	–	–	ns
$t(mov)$	Master output valid	-5.0	–	5.0	ns
$t(mis)$	Master input setup	5.0	–	–	ns
$t(mih)$	Master input hold	1.0	–	–	ns

1. The minimum clock period includes 1% jitter of the maximum frequency.

Figure 7. SPI timing parameters

### 2.7.3. PCM Interface

IMQ8F4 modules provide one PCM master digital audio interface. Keep PCM signal traces far away from noise and radiating signal on PCB



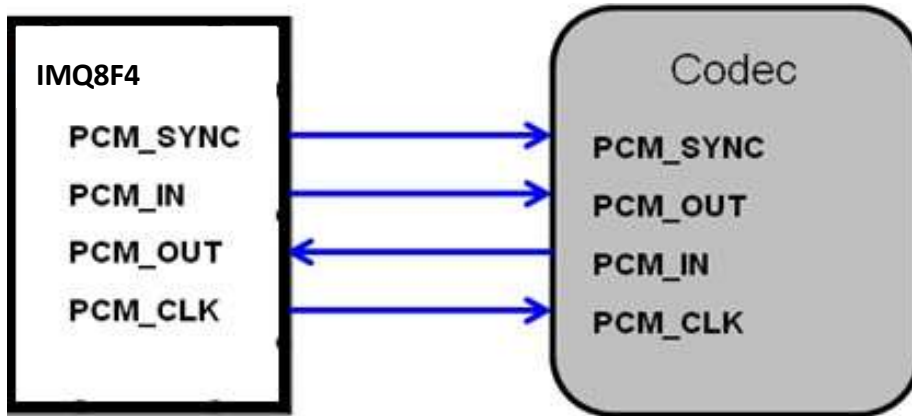

Figure 8. PCM connection (example)

Timing

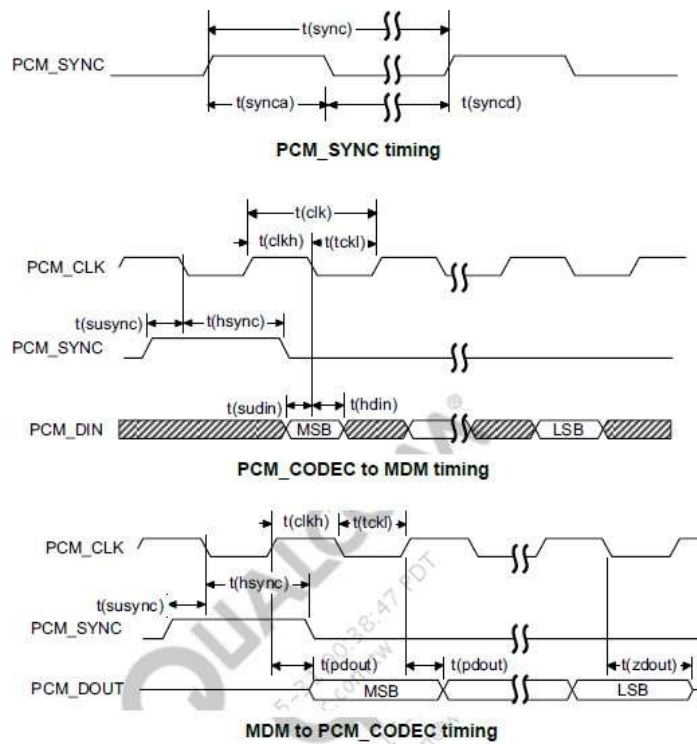

Figure 9. PCM timing diagram



Parameter		Comments	Min	Typ	Max	Unit
t(sync)	PCM_SYNC cycle time		–	125	–	µs
t(synca)	PCM_SYNC asserted time		–	488	–	ns
t(syncd)	PCM_SYNC de-asserted time		–	124.5	–	µs
t(clk)	PCM_CLK cycle time		–	488	–	ns
t(clkh)	PCM_CLK high time		–	244	–	ns
t(clkl)	PCM_CLK low time		–	244	–	ns
t(susync)	PCM_SYNC offset time to PCM_CLK falling		–	122	–	ns
t(sudin)	PCM_DIN setup time to PCM_CLK falling		60	–	–	ns
t(hdin)	PCM_DIN hold time after PCM_CLK falling		10	–	–	ns
t(pdout)	Delay from PCM_CLK rising to PCM_DOUT valid		–	–	60	ns
t(zdout)	Delay from PCM_CLK falling to PCM_DOUT HIGH-Z		–	160	–	ns

Figure 10. PCM timing parameters

### 2.7.4. I2S Interface

PCM and I2S share the same pins on the modules, I2C only support master mode, keep I2S signal trace far away from noise and radiating signal on PCB

Config1	Config2
PCM_SYNC	I2S_WS
PCM_DIN	I2S_DATA0
PCM_DOUT	I2S_DATA1
PCM_CLK	I2S_SCK

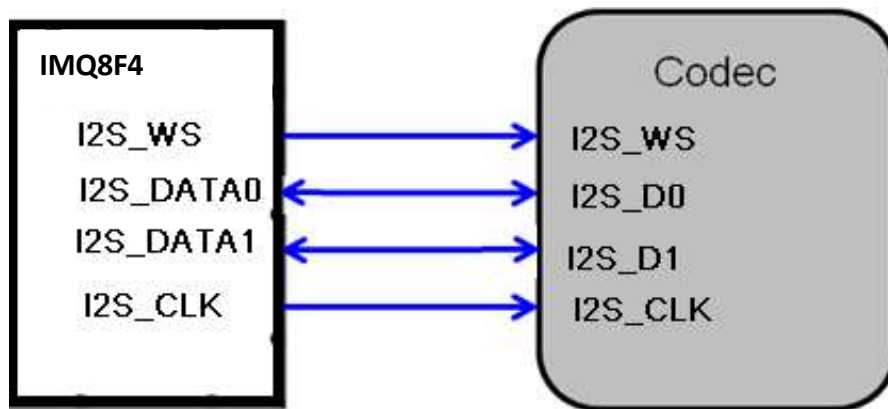

Figure 11. I2S connection (example)

### Timing

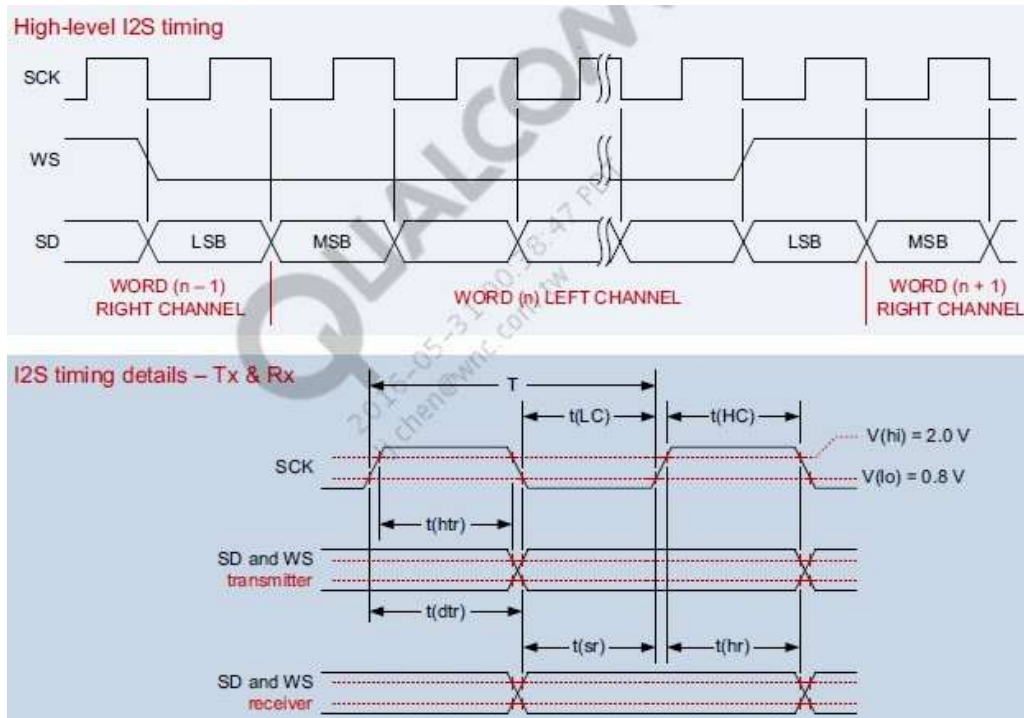

Figure 12. I2S timing diagram

Parameter	Comments <sup>1</sup>	Min	Typ	Max	Unit
<i>Using internal SCK</i>					
Frequency		-	-	12.288	MHz
T	Clock period	81.380	-	-	ns
t(HC)	Clock high	0.45 · T	-	0.55 · T	ns
<i>Using external SCK</i>					
Frequency		-	-	12.288	MHz
T	Clock period	81.380	-	-	ns
t(HC)	Clock high	0.45 · T	-	0.55 · T	ns
t(LC)	Clock low	0.45 · T	-	0.55 · T	ns
t(sr)	SD and WS input setup time	16.276	-	-	ns
t(hr)	SD and WS input hold time	0	-	-	ns
t(dtr)	SD and WS output delay	-	-	65.100	ns
t(htr)	SD and WS output hold time	0	-	-	ns

1. Load capacitance is between 10 and 40 pF.

Figure 13. I2S timing parameters

### 2.7.5. I2C Interface

IMQ8F4 modules provide one I2C interface, I2C only support master mode.

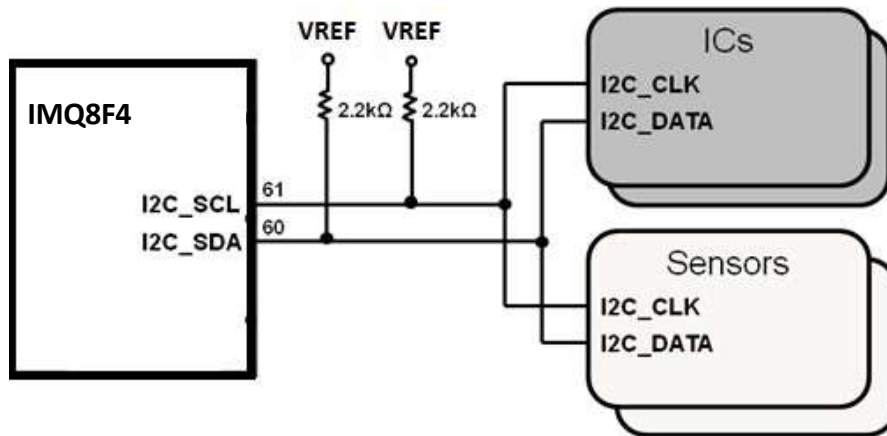

Figure 14. I2C connection (example)

### 2.7.6. UART Interface

There are two UART interfaces on IMQ8F4: One is a 4 bit UART(UART1) for high-speed data transfer, max baud rate can be up to 4Mbps. Another is a 2 bit UART(UART2) for diagnostic tools and debugging, the default baud rate 115200bps is recommended.

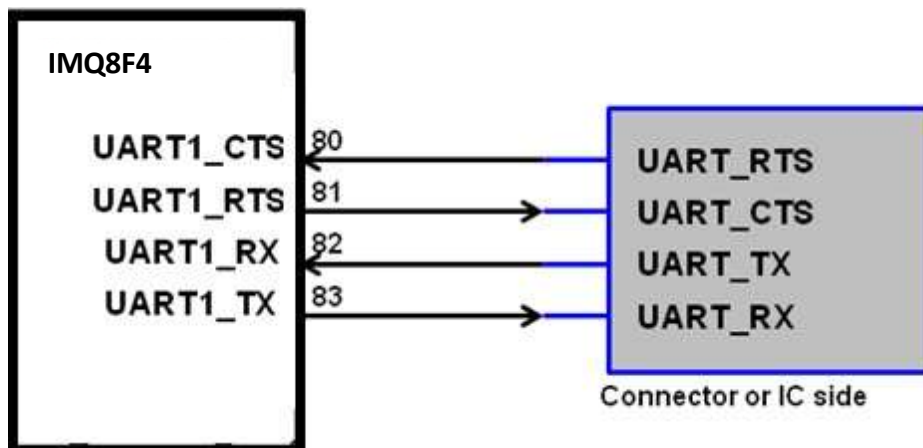

Figure 15. UART connection (example)

### 2.7.7. ADC Interface

An Analog to Digital Converter (ADC) input is provided by the IMQ8F4. The converter is 16 bit resolution, ranging from 0.1 V to 1.7 V, with a sampling rate of 2.4 MHz.

Parameter	Comments	Minimum	Typ	Maximum	Units
Supply voltage	Connected internally to VREG_L3	-	1.8	-	V
Resolution	Decimated data	-	-	15	bits
Analog-input bandwidth		-	100	-	kHz
Sample rate	XO/8	-	2.4	-	MHz
Offset error	Relative to full-scale	-1	-	+1	%
Gain error	Relative to full-scale	-1	-	+1	%
INL	15-bit output	-8	-	+8	LSB
DNL	15-bit output	-4	-	+4	LSB

Figure 16. Analog-to-digital specification

**Layout suggestion:**

- ADC signal trace should be well protected by GND plane
- ADC signal trace should be protected from noise and other radiating signals

### 2.7.8. Secure digital interfaces

IMQ8F4 provides one SDIO interface, muxed with other functionalities, 4-bit 1.8 V for WLAN interface.

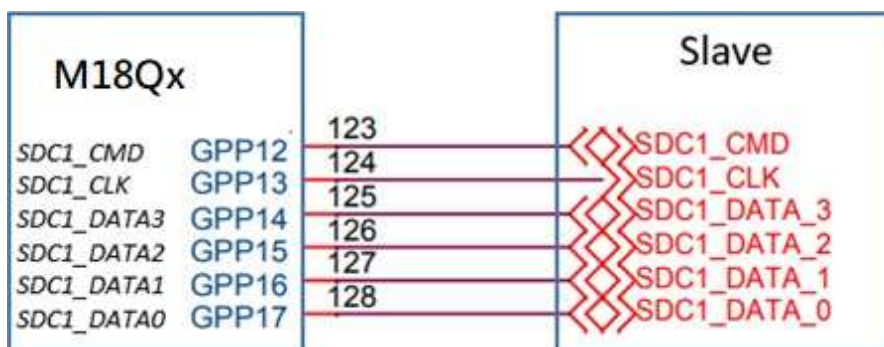

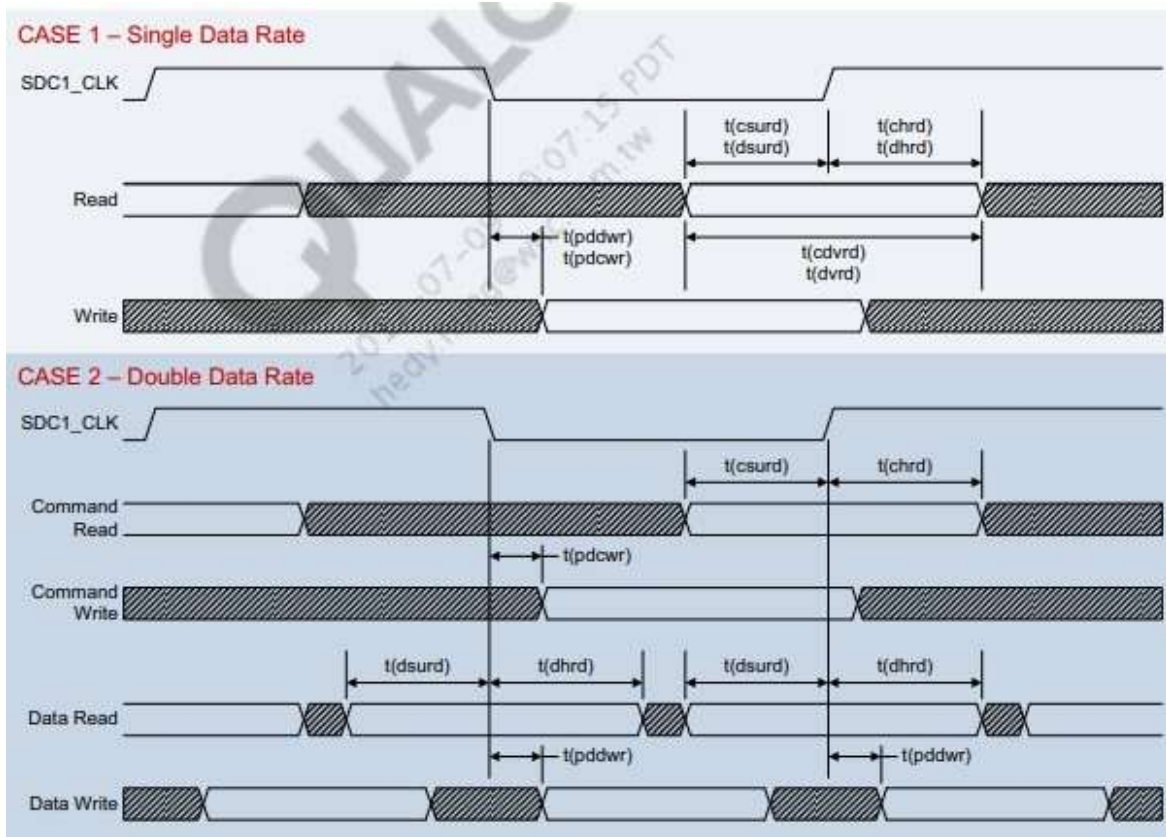

Parameter		Min	Typ	Max	Unit
<b>Single data rate (SDR) mode – SDC1 up to 200 MHz</b>					
t(cdvr)	Command valid	2.4	–	–	ns
t(dvrd)	Data valid	2.4	–	–	ns
t(pddwr)	Propagation delay on data write	-1.45	–	0.85	ns
t(pdcwr)	Propagation delay on command write	-1.45	–	0.85	ns
<b>Double data rate (DDR) mode – SDC1 up to 52 MHz</b>					
t(chrd)	Command hold	1.5	–	–	ns
t(csurd)	Command setup	5.53	–	–	ns
t(dhrd)	Data hold	1.5	–	–	ns
t(dsurd)	Data setup	1.65	–	–	ns
t(pddwr)	Propagation delay on data write	2.5	–	6.15	ns
t(pdcwr)	Propagation delay on command write	-7.85	–	2.65	ns

Figure 17. SDIO timing

### 3. RF Specifications

#### 3.1. RF connections

The IMQ8F4 modules have three RF pads; developers must connect them via 50 Ω traces to the main board.

- ANT0\_TRX pad (Pin15) – Primary RX/TX path
- ANT1\_DRX pad (Pin21) – Diversity path
- ANT\_GNSS pad (Pin9) – GNSS path (For IMQ8F4)

It is recommended that grounds not be present under the surface of the RF pads in the layout. Details are included below. Layer2 has the same keep out size as Layer1

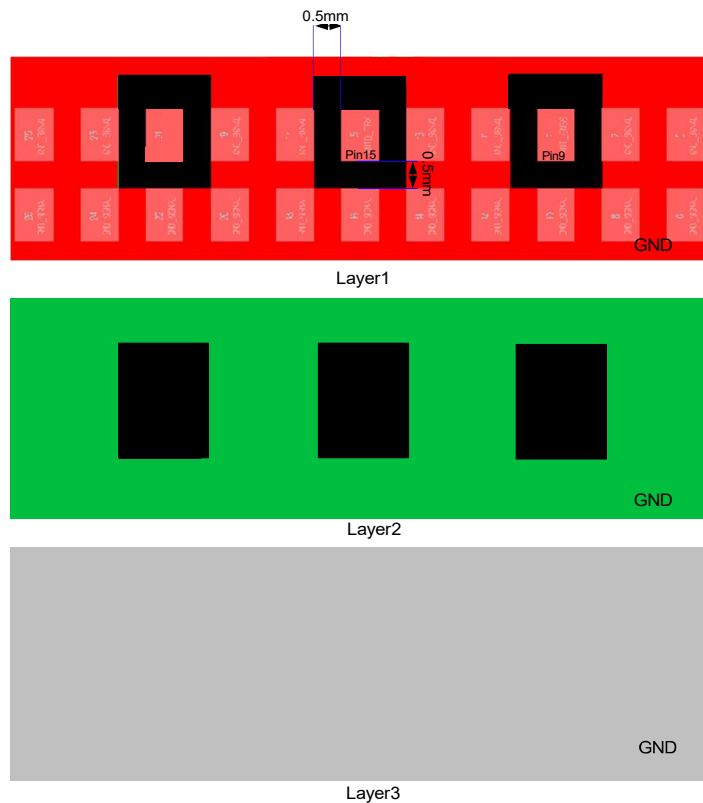

Figure 18. RF pad layout suggestion



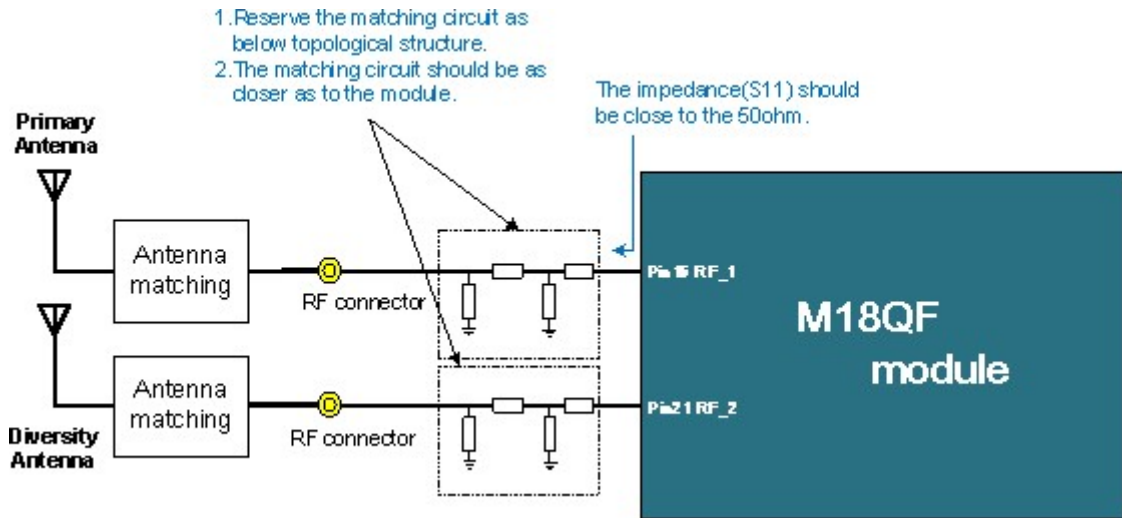

Figure 19. RF matching guide

## 3.2. Interference and sensitivity

This section includes tips to assist developers in identifying the interference that may affect IMQ8F4 modules when used in systems.

- Interference from other wireless devices
  - Harmonics, inter-modulated signal generated from wireless devices that fall in RX ranges of the modules, may result in degraded RX performance.
  - It is highly recommended to check RX performance of entire systems within the shielding environment.
- Interference from host interface
  - High-speed signal-switching elements in systems can easily couple noise into the module (Ex.: DDR memory, LCD modules, DC-DC converter, PCM signal).
- Methods to avoid sources of interference
  - Antenna location is important; we recommend directing the antenna

away from high-speed switching signals. Furthermore, the trace from the module to the antenna should be as short as possible and must be shielded by complete grounding.

- The IMQ8F4 modules are well shielded; the high-speed elements (Ex.: DDR memory, LCD modules, DC-DC converter, PCM signal) on a system should have shielding reserved during the early stages of development.



**Caution:** DDR bus, LCD bus, DC-DC switching and PCM signals are easily to influence the WWAN and GNSS receiver performance, these signals must to be routed in the inner layer of the PCB and far away from the WWAN and GNSS receiver path.

### 3.3. GNSS external circuit design

One Notch filter, GNSS SAW filter, LNA, and another GNSS SAW filter need to be used between the module and antenna. Detail design guide as below.

#### IMQ8F4 module without Band 14

1. Minimize GNSS trace length from antenna to Module.
2. Maximize overall efficiency in antenna design and maximize isolation Between GNSS and other transmit antennas to limit transmitter Leakage into the GNSS Rx path.
3. Isolate GNSS antenna from jammer sources, digital traces, and power traces, especially SMPS outputs.
4. Noisy digital circuits such as the SIM card, USB interface, Camera Module, Display connector, speaker and other audio circuits, and SD/ MMC card should be away from the GNSS antenna.

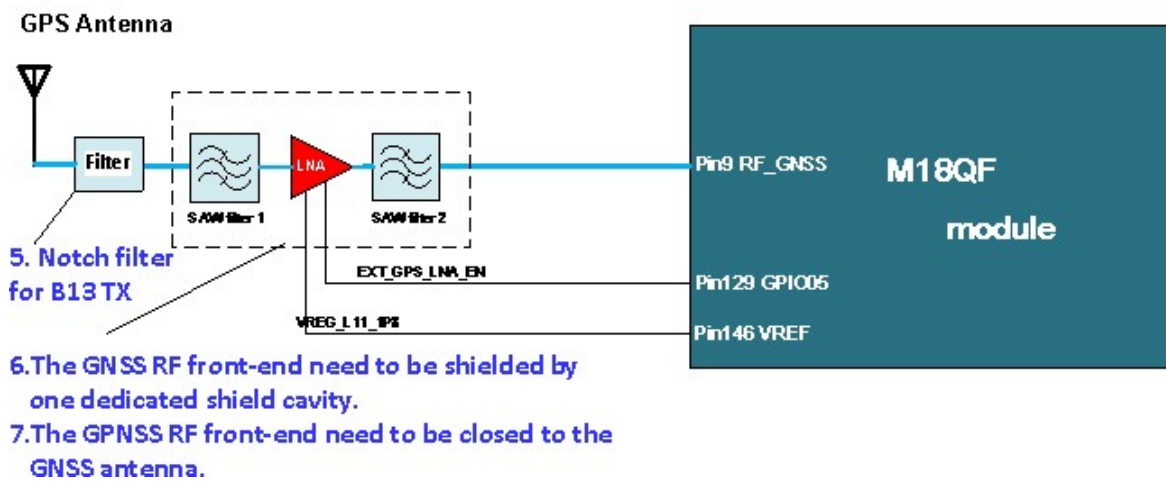

Figure 20. GNSS design suggestion

The following SAW filter and LNA components have been implemented by WNC development board.

- SAW filter1: Murata SAFFB1G56KB0F0AR15
- LNA: INFINEON BGA824N6
- SAW filter2: Murata SAFFB1G56KB0F0AR15

If use module embedded GNSS, please follow above reference design. Pin146 (VREF, 1.8V) of module connects to the external LNA power supply pin. Pin129 (GPIO05) of module connects to external LNA enable control pin.

The Notch filter reference design as below:

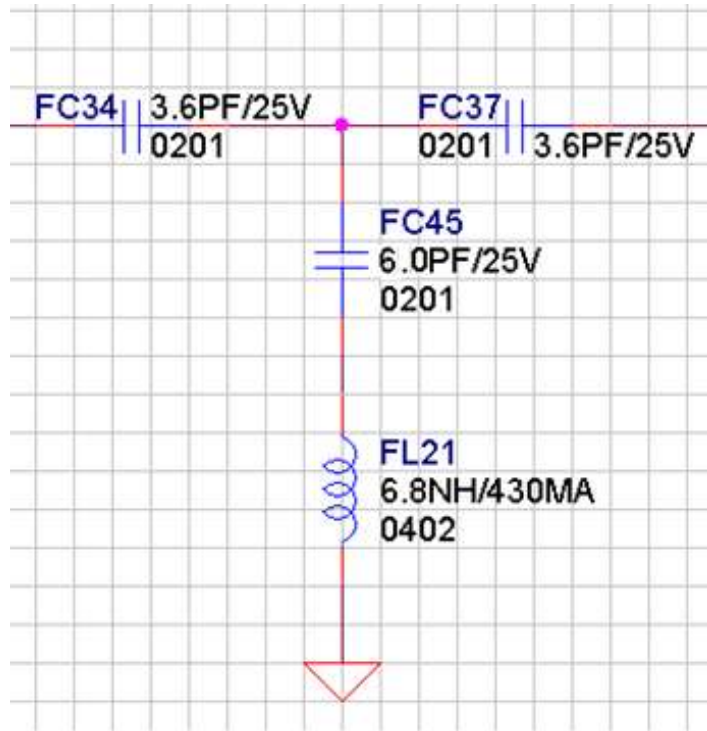

### 3.4. RF Specification

#### 3.4.1 Band support

Table 9. Band support

Band	Uplink (MHz)	Downlink (MHz)
LTE Band 2	1850–1910	1930–1990
LTE Band 4	1710–1755	2110–2155
LTE Band 5	824–849	869–894
LTE Band 12	699–716	729–746
LTE Band 13	777-787	746-756
LTE Band 25	1850-1915	1930-1995
LTE Band 26	814-849	859-894
LTE Band 66	1710-1780	2110-2200
LTE Band 71	663-698	617-652
Band	Uplink (MHz)	Downlink (MHz)
WCDMA Band 2	1850–1910	1930–1990
WCDMA Band 5	824–849	869–894



### 3.4.2 Bandwidth support

Table 10. Bandwidth support

Band	Bandwidth					
	1.4 MHz	3 MHz	5 MHz	10 MHz	15 MHz	20 MHz
LTE Band 2	✓	✓	✓	✓	✓	✓
LTE Band 4	✓	✓	✓	✓	✓	✓
LTE Band 5	✓	✓	✓	✓	-	-
LTE Band 12	✓	✓	✓	✓	-	-
LTE Band 13	-	-	✓	✓	-	-
LTE Band 25	✓	✓	✓	✓	✓	✓
LTE Band 26	✓	✓	✓	✓	✓	-
LTE Band 66	✓	✓	✓	✓	✓	✓
LTE Band 71	-	-	✓	✓	✓	✓

### 3.4.3 RF Transmit Specification

Table 11. Conductive Tx output power

Band	Items	Parameter	Unit	Min.	Typ.	Max.
LTE Band 2	Max. TX Power	10 MHz 12 RBs/QPSK	dBm	20.3	23	25.7
LTE Band 4	Max. TX Power	10 MHz 12 RBs/QPSK	dBm	20.3	23	25.7
LTE Band 5	Max. TX Power	10 MHz 12 RBs/QPSK	dBm	20.3	23	25.7
LTE Band 12	Max. TX Power	10 MHz 12 RBs/QPSK	dBm	20.3	23	25.7
LTE Band 13	Max. TX Power	10 MHz 12 RBs/QPSK	dBm	20.3	23	25.7
LTE Band 25	Max. TX Power	10 MHz 12 RBs/QPSK	dBm	20.3	23	25.7
LTE Band 26	Max. TX Power	10 MHz 12 RBs/QPSK	dBm	20.3	23	25.7
LTE Band 66	Max. TX Power	10 MHz 12 RBs/QPSK	dBm	20.3	23	25.7
LTE Band 71	Max. TX Power	10 MHz 12 RBs/QPSK	dBm	20.3	23	25.7
Band	Items	Parameter	Unit	Min.	Typ.	Max.
WCDMA Band 2	Max. TX power	-	dBm	20.3	23.5	25.7
WCDMA Band 5	Max. TX power	-	dBm	20.3	24	25.7

Note: 1.The RF Transmit Specification is defined at the LGA pad.  
 2. IM8QF4 meet 3GPP TS 36.521-1/TS 34.121-1 test standard.



3.4.4 RF Receiver Specification

Table 12. Conductive Rx sensitivity-3GPP

Band	Items	Parameter	Unit	Typ.	3GPP standard limit
LTE Band 2	RX Sensitivity	10 MHz with 50 RBs	dBm	-102.3	-94.3
LTE Band 4	RX Sensitivity	10 MHz with 50 RBs	dBm	-102.1	-96.3
LTE Band 5	RX Sensitivity	10 MHz with 50 RBs	dBm	-103.3	-94.3
LTE Band 12	RX Sensitivity	10 MHz with 50 RBs	dBm	-102.6	-93.3
LTE Band 13	RX Sensitivity	10 MHz with 50 RBs	dBm	-102.2	-93.3
LTE Band 25	RX Sensitivity	10 MHz with 50 RBs	dBm	-101.9	-92.8
LTE Band 26	RX Sensitivity	10 MHz with 50 RBs	dBm	-103.6	-93.8
LTE Band 66	RX Sensitivity	10 MHz with 50 RBs	dBm	-102.1	-95.8
LTE Band 71	RX Sensitivity	10 MHz with 50 RBs	dBm	-103.2	-93.5
Band	Items	Parameter	Unit	Typ.	3GPP standard limit
WCDMA Band 2	RX Sensitivity		dBm	-114	-95
WCDMA Band 5	RX Sensitivity		dBm	-114	-95

- Note: 1. The RF Receiver Specification is defined at the LGA pad.  
 2. Meet 3GPP TS 36.521-1/TS 34.121-1 test standard.

Table 13. Conductive Rx sensitivity-CTIA

The below table show the sensitivity data of primary only and second only which is defined in the **CTIA Test Plan for Wireless Device Over-the-Air Performance V 3.4.2 Table 6-6**. This data could be the reference in the OTA performance evaluation.

Band	Channel Bandwidth (MHz)	Channel	RX Frequency (MHz) [center of DL RB allocation]	UL RB Allocation	DL RB Allocation	Primary only -Typical (dBm)	Second only -Typical (dBm)
2	10	650	1935	50 RB with RBstar t=0	50 RB with RBstart=0	-99.0	-99.1
		900	1960	50 RB with RBstar t=0	50 RB with RBstart=0	-99.1	-99.2



		1150	1985	50 RB with RBstar t=0	50 RB with RBstart=0	-99.5	-98.8
		2000	2115	50 RB with RBstar t=0	50 RB with RBstart=0	-99.1	-98.9
4	10	2175	2132.5	50 RB with RBstar t=0	50 RB with RBstart=0	-99.4	-99.3
		2350	2150	50 RB with RBstar t=0	50 RB with RBstart=0	-99.0	-99.1
		2450	874	50 RB with RBstar t=0	50 RB with RBstart=0	-100.4	-100.7
5	10	2525	881.5	50 RB with RBstar t=0	50 RB with RBstart=0	-100.4	-100.4
		2600	889	50 RB with RBstar t=0	50 RB with RBstart=0	-100.2	-100.3
12	10	5060	734.0	50 RB with RBstar t=0	50 RB with RBstart=0	-99.5	-100.0
		5095	737.5	50 RB with RBstar t=0	25 RB with RBstart=0	-99.7	-100.2



		5130	741.0	50 RB with RBstar t=5	25 RB with RBstart=0	-99.6	-99.7
13	10	5230	751	50 RB with RBstar t=0	50 RB with RBstart=0	-99.5	-99.7
		8090	1935	50 RB with RBstar t=0	50 RB with RBstart=0	-99.0	-98.9
25	10	8365	1962.5	50 RB with RBstar t=0	50 RB with RBstart=0	-99.2	-99.3
		8640	1990	50 RB with RBstar t=0	50 RB with RBstart=0	-99.2	-98.8
		8740	864	50 RB with RBstar t=0	50 RB with RBstart=0	-100.2	-100.4
26	10	8865	876.5	50 RB with RBstar t=0	50 RB with RBstart=0	-100.6	-100.8
		8990	889	50 RB with RBstar t=0	50 RB with RBstart=0	-100.2	-100.3
		66486	2115	50 RB with RBstar t=0	50 RB with RBstart=0	-99.2	-98.9



66	10	66786	2145	50 RB with RBstar t=0	50 RB with RBstart=0	-99.3	-99.4
		67086	2175	50 RB with RBstar t=0	50 RB with RBstart=0	-99.4	-98.9
71	10	68636	622	50 RB with RBstar t=0	50 RB with RBstart=0	-100.2	-100.1
		68761	634.5	50 RB with RBstar t=0	50 RB with RBstart=0	-100.1	-100.5
		68886	647	50 RB with RBstar t=0	50 RB with RBstart=0	100.3	-100.5

Note: 1. The RF typical data is defined at the LGA pad.



### 3.4.5 GNSS Receiver Specification

Table 14. GNSS receiver performance

Test items	Parameter	Min.	Typ.	Max.
Cold start TTFF	(@-130dBm)	-	38S	-
Hot start TTFF	(@-130dBm)	-	2S	-
CEP-50 Accuracy	Open sky with -130 dBm input	-	<3m	-
Cold start sensitivity	Acquire First with Signal level	-	-146dBm	-
Tracking sensitivity(GPS)	Detect an in-view satellite 50% of the time	-158dBm	-160dBm	-
Tracking sensitivity (Glonass)	Detect an in-view satellite 50% of the time	-158dBm	TBD	-

Note1: The test point shows as below.

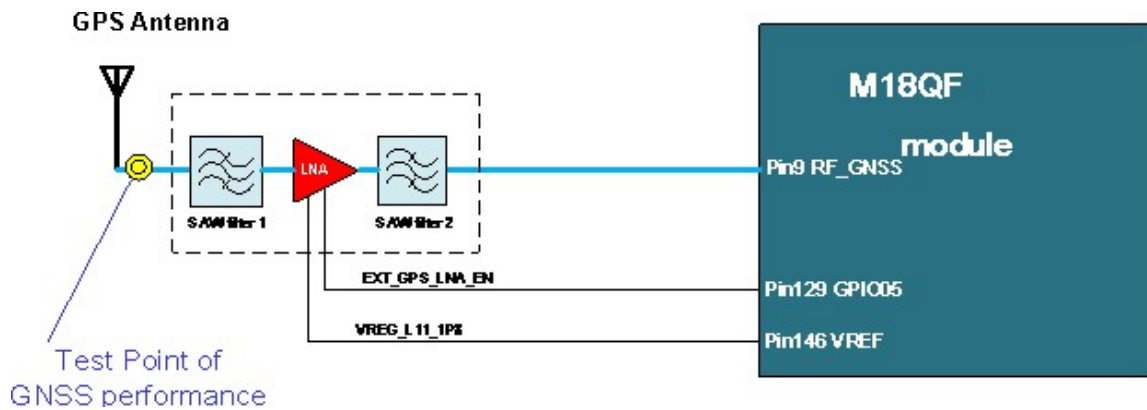

## 4. Power

### 4.1. Power consumption

This section describes typical power consumption of IMQ8F4 for reference. The current data is measured with Linux kernel v3.18 in IMQ8F4 that is powered by VCC 3.8V, connected with LTE emulator. The measured data is subject to IMQ8F4 kernel version upgrade.

Table 15. LTE power consumption

Working Mode	Conditions	Result	
		min.	max.
<b>Airplane mode</b>			
	Only Module, no other device	1.00mA	1.6mA
<b>LTE standby (DRX=1.28 sec, BW=10MHz)</b>			
	Band2/ Band4/ Band5/ Band12/ Band13	TBD	TBD
<b>LTE Band2 Working mode</b>			
	Bandwidth 20MHz, TM3-DLRB 100-ULRB 100- IPV4-UDP , TX Power=23dbm, Downlink throughput is 145Mbps via USB interface by Iperf tool	TBD	TBD
<b>LTE Band4 Working mode</b>			
	Bandwidth 20MHz, TM3-DLRB 100-ULRB 100-IPV4-UDP , TX Power=23dbm, Downlink throughput is 145Mbps via USB interface by Iperf tool	TBD	--
<b>LTE Band5 Working mode</b>			
	Bandwidth 10MHz, TM3-DLRB 50-ULRB 50- IPV4-UDP, TX Power=23dbm, Downlink throughput is 72Mbps via USB interface by Iperf tool	TBD	--
<b>LTE Band12 Working mode</b>			
	Bandwidth 10MHz, TM3-DLRB 50-ULRB 50-IPV4-UDP , TX Power=23dbm, Downlink throughput is 72Mbps via USB interface by Iperf tool	TBD	--
<b>LTE Band13 Working mode</b>			
	Bandwidth 10MHz, TM3-DLRB 50-ULRB 50-IPV4-UDP , TX Power=23dbm, Downlink throughput is 72Mbps via USB interface by Iperf tool	TBD	--

<b>WCDMA standby(DRX=1.28 sec)</b>			
	Band2 –WCDMA Standby mode, DRX = 1.28 sec	TBD	--
	Band5 –WCDMA Standby mode, DRX = 1.28 sec	TBD	--
<b>WCDMA Band2 Working mode</b>			
	HSPA+ downlink 21 Mbps ,TX Power=23dbm	TBD	--
<b>WCDMA Band5 Working mode</b>			
	HSPA+ downlink 21 Mbps ,TX Power=23dbm	TBD	--
<b>Powering on</b>	<b>Conditions</b>	<b>Result</b>	
<b>Peak power consumption</b>			
	Power consumption peak when the module is powering up	550mA	--
<b>Power off</b>	<b>Conditions</b>	<b>Result</b>	
<b>Power off consumption</b>			
	Module is powered off	5uA	10uA

Note: 1. USB and GPS are disabled when testing airplane mode and standby mode.



## 5. Software Interface

### 5.1. Support tools

The IMQ8F4 modules are compatible with the following support tools:

- WNC IMQ8F4 Connection Manager (WNCCM)

### 5.2. USB interface

The IMQ8F4 modules support 3GPP standard AT commands and proprietary AT commands; the MAL Manager SDK is also supported for Linux platforms. Refer to [WNC IMQ8F4/M18QA Series] WNC MAL Manager Developer Guide for more information.

## 6. Mechanical and Environmental Certifications

### 6.1. PCBA Form Factor

IMQ8F4 modules have the same dimensions:  
 31.32 mm (typ.) × 23.5 mm (typ.) × 2.35 mm (typ.)

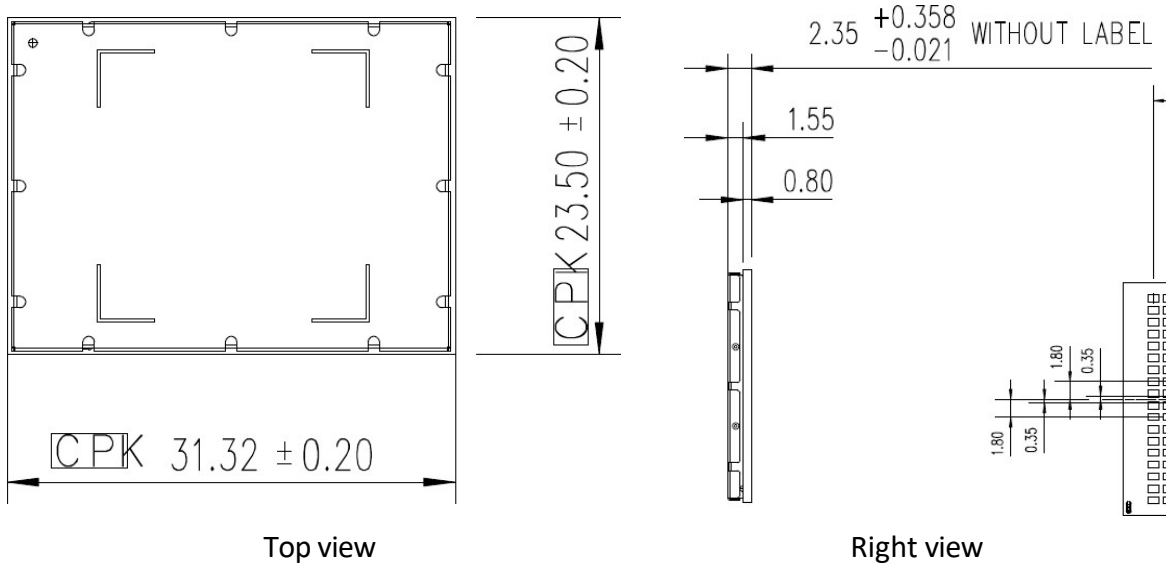

Figure 21. PCBA dimension



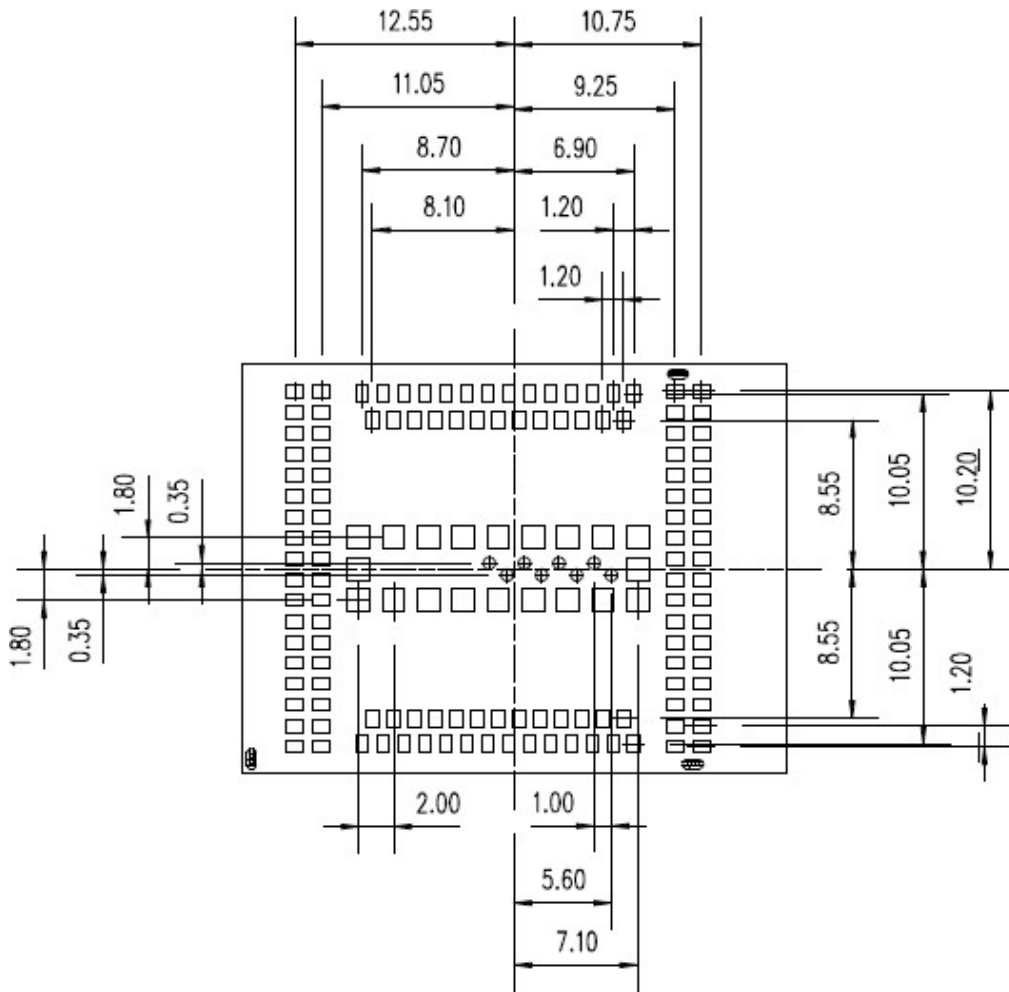

Figure 22. Pad dimension(Bottom view)

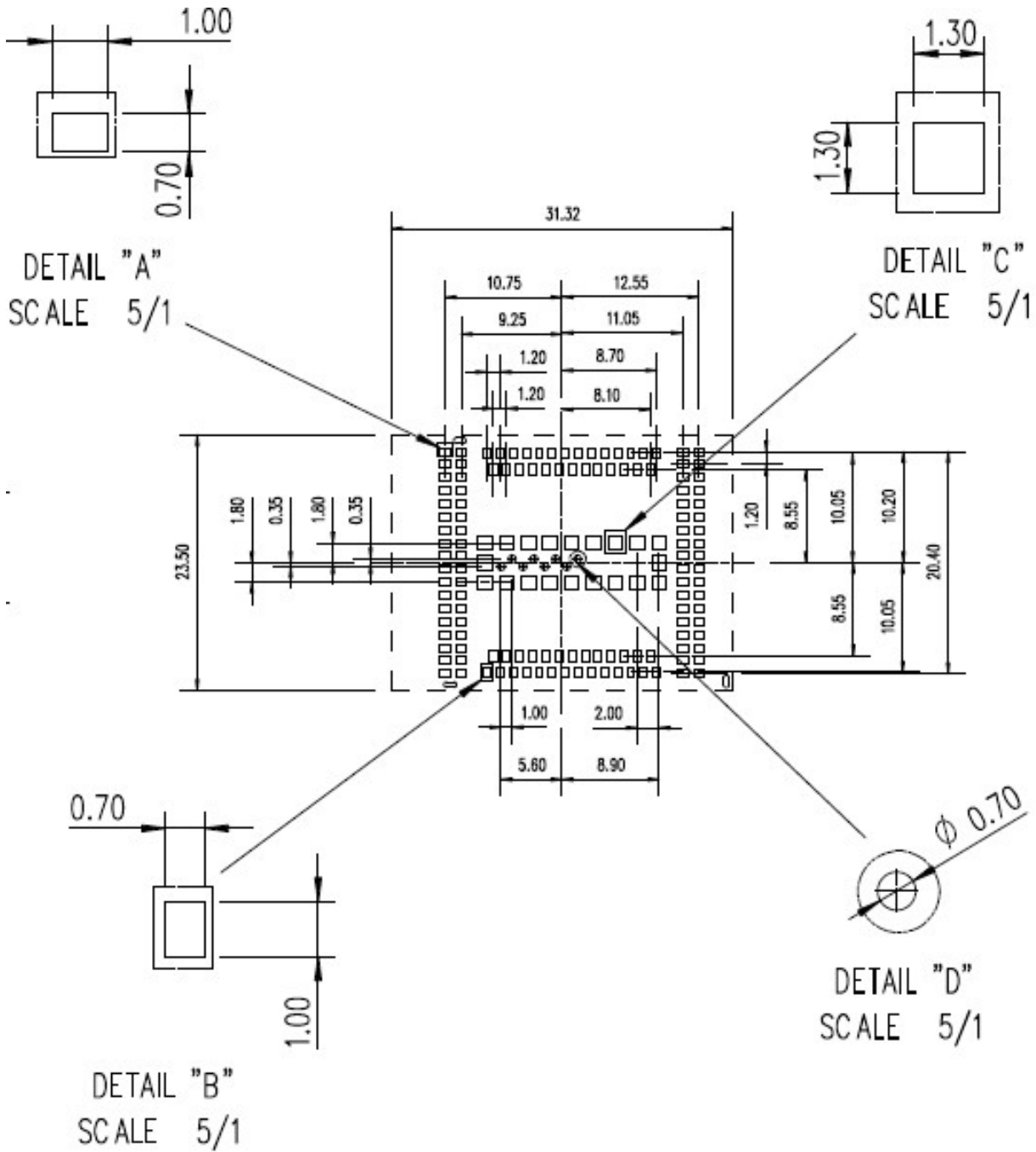
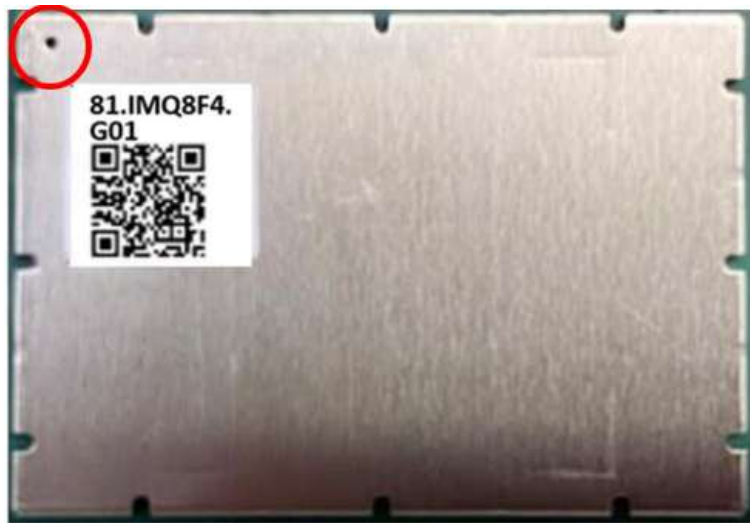
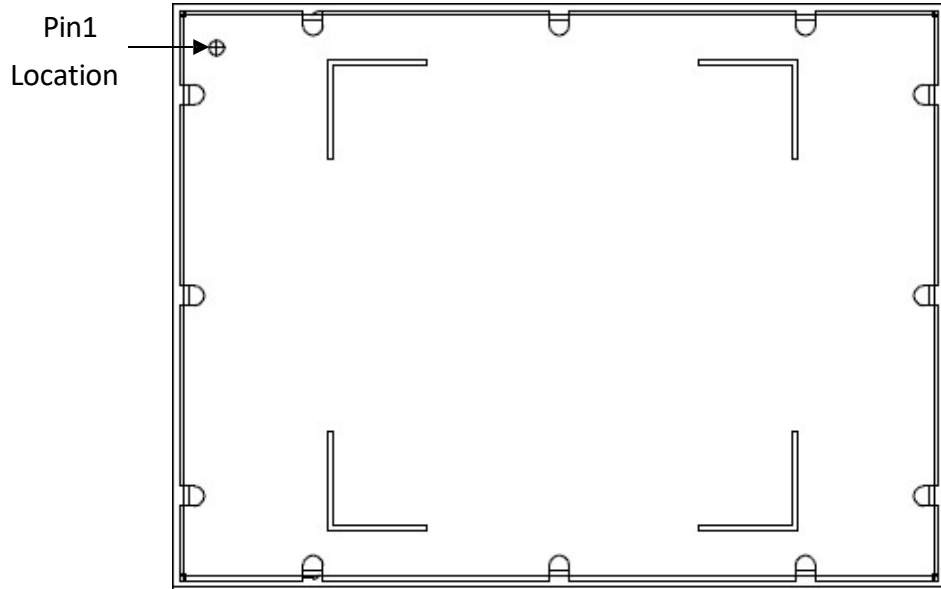

Figure 23. PCB footprint suggestion



## 6.2. Module orientation



### 6.3. Reflow

This section details the recommended reflow profile when the module is mounted onto other boards.

Temp. Region	1	2	3	4	5	6	7	8	9	10
Upper temp. region	150	165	175	180	195	205	230	235	250	245
Lower temp. region	150	165	175	180	195	205	230	235	250	245
Conveyer band speed	95 cm/minute									

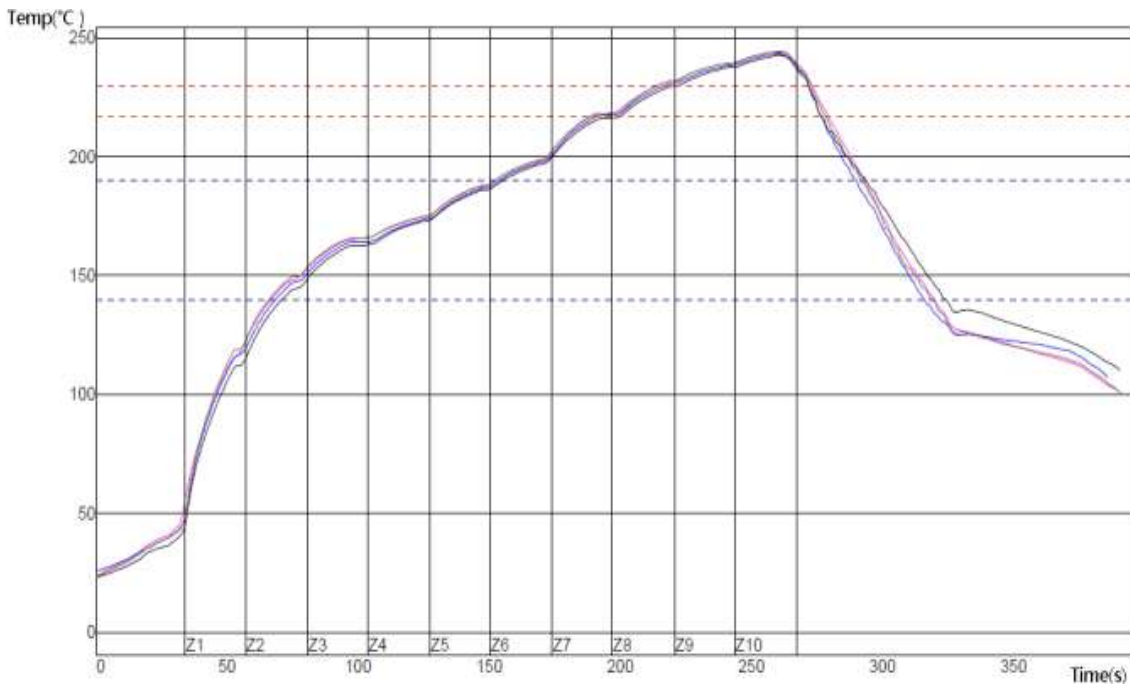

PWI = 91%	D31-1	D31-2	D31-3	D31-4	Temp. Difference
<b>Preheat from 140–190°C</b>					
85.34	85.30	86.06	84.29	1.77	
-12%	-13%	-8%	-18%		
<b>Melt-out Time/230°C</b>					
59.07	55.03	58.70	49.70	9.37	
91%	50%	87%	-3%		
<b>Max Temp</b>					
244.27	243.56	244.33	242.71	1.62	
43%	36%	43%	27%		



<b>Total Time/217°C</b>				
90.55	85.88	90.09	76.90	13.65
22%	4%	20%	-32%	
<b>Gradient1 (100–150°C)</b>				
1.91	1.83	1.93	1.78	0.15
27%	22%	29%	19%	

Process limit:

Solder Paste Profile feature	Lead-free		Unit
	Min.	Max.	
<b>Gradient1 (Target = 1.5) (100 °C–150 °C) (Time period = 20 s)</b>	0	3	°C/S
<b>Preheat time from 140 °C to 190 °C</b>	70	105	S
<b>Time maintained above 230 °C</b>	40	60	S
<b>Peak package body temperature</b>	230	250	°C
<b>Time maintained above 217 °C</b>	60	110	S

### 6.4. PCB pad design

Non solder mask defined (NSMD) type is recommended for the solder pads of the PCB on which IMQ8F4 Series modules will be mounted, this kind of design is good to soldering reliability in SMT process.

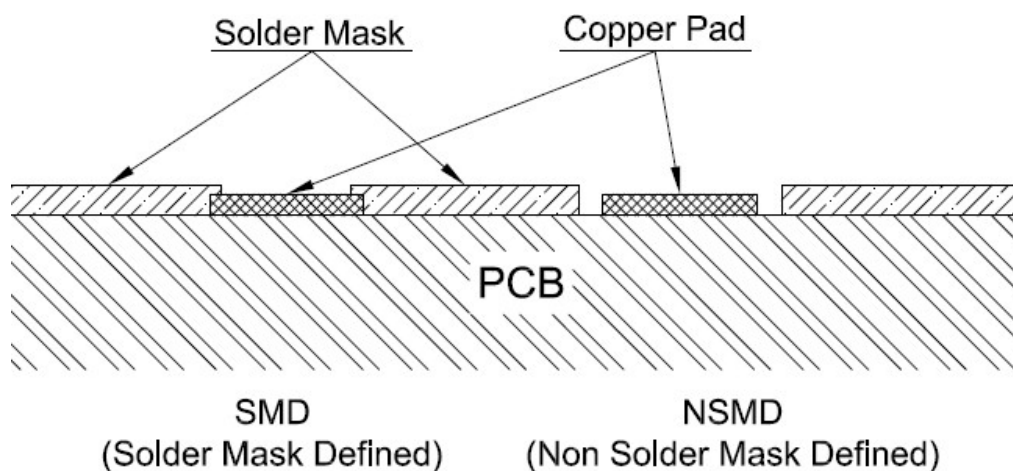
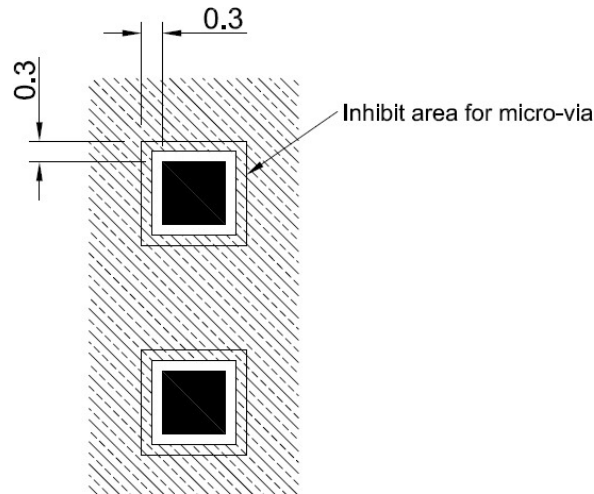

Figure 24. NSMD solder pad design



It is not recommended to place via or micro-via not covered by solder resist in an area of 0.3 mm around the pads unless it carries the same signal of the pad itself, see following figure.



Holes in pad are allowed only for blind holes and not for through holes.

## 6.5. Labeling

Figure26 shows label drawing of IMQ8F4 modules.



Figure 25. Label drawing

## 6.6. SMT Voids control

### 6.6.1. Mother board PCB thickness

Thin mother board is prone to warping during SMT reflow, which creates voids when the module is soldered. Therefore, the thickness of the mother board needs to be larger than 1.2 mm, and the larger the size of the mother board, the larger the thickness. For example, 1.4mm, 1.6mm.

### 6.6.2. Stencil design

The thickness of the stencil is at least 0.15 mm, and the thickness of the stencil need to be increased depending on the actual situation. For example, there is open soldering still.

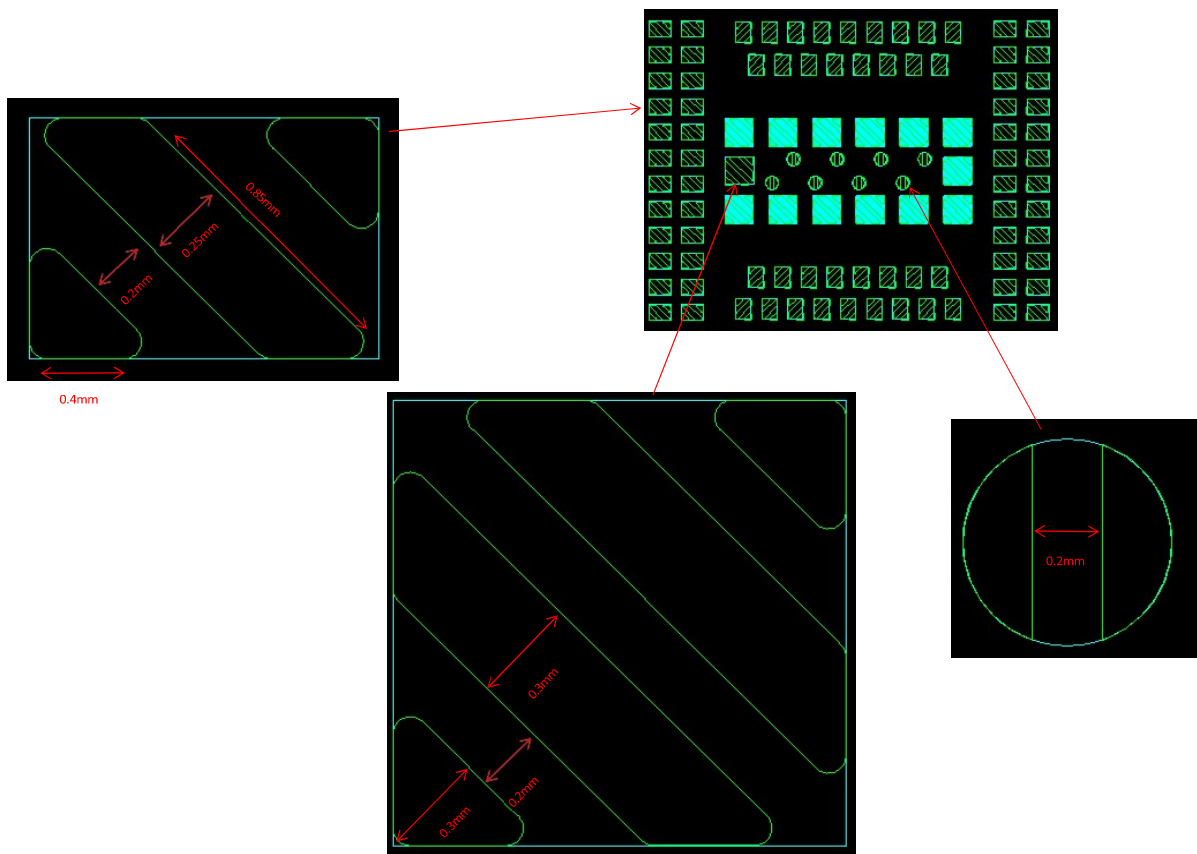

Figure 26. Stencil-foil drawing

## 6.7. Thermal considerations

Grade	Operating	3GPP compliant	Functional work	Storage
Industrial	-40 °C~+85 °C	-20 °C~+60 °C	-40 °C~+85 °C	-40 °C ~+85 °C

Note: The temperature above refers to ambient temperature.

The case temperature of module shielding cover must be < 85 °C when integrated to prevent damage.

Design points used to improve the thermal performance:

- It's better to add a naked copper area onto IMQ8F4 modules' back side of the PCB. If the thermal performance becomes an issue in the customer's product, add thermal solutions for improvement such as a thermal pad or a heat sink.
- It's recommended to have a thermal pad or a heat sink on shielding cover to help transfer heat.
- If systems with IMQ8F4 modules embedded intend to work under ambient temperatures as low as -40°C, it's suggested that:
  1. SIM Card need to be well arranged to make sure it is functional at the condition of ambient temperature as low as -40°C.
  2. Adding heating circuit on board design, the circuit mainly consists of temperature sensing unit, heating element and control unit.

## 7. Regulatory Compliance and Certification

### 7.1. Certification testing

PTCRB, GCF, FCC, IC, AT&T TA and Verizon TA

## 8. Packaging

### 8.1. Tape-and-Reel Package

The IMQ8F4 modules are delivered in tape and reel.

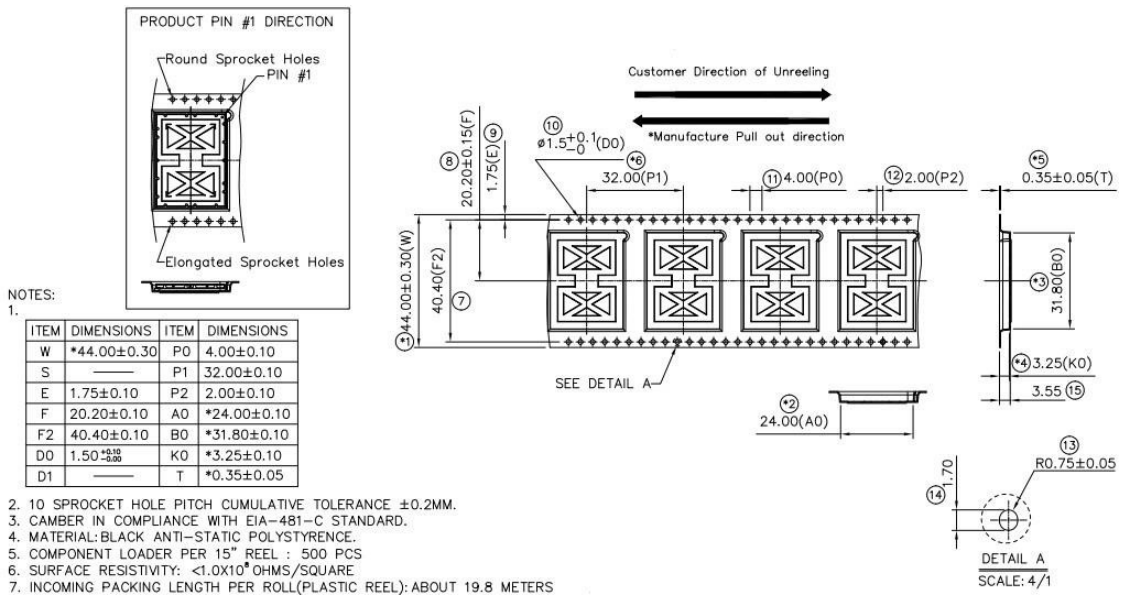

Figure 27. Packing--tape

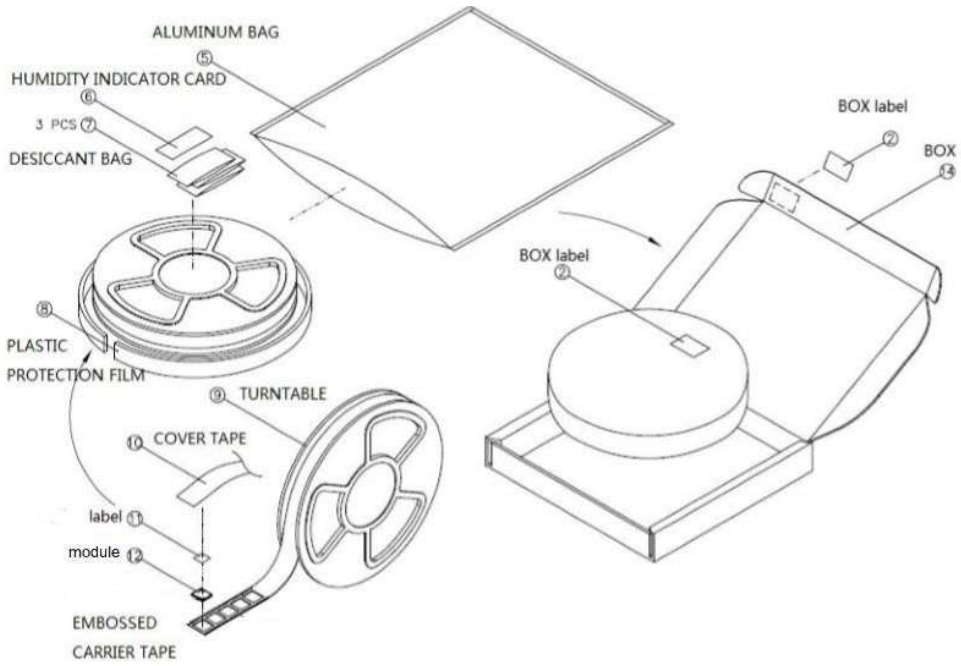

Figure 28. Packing—reel

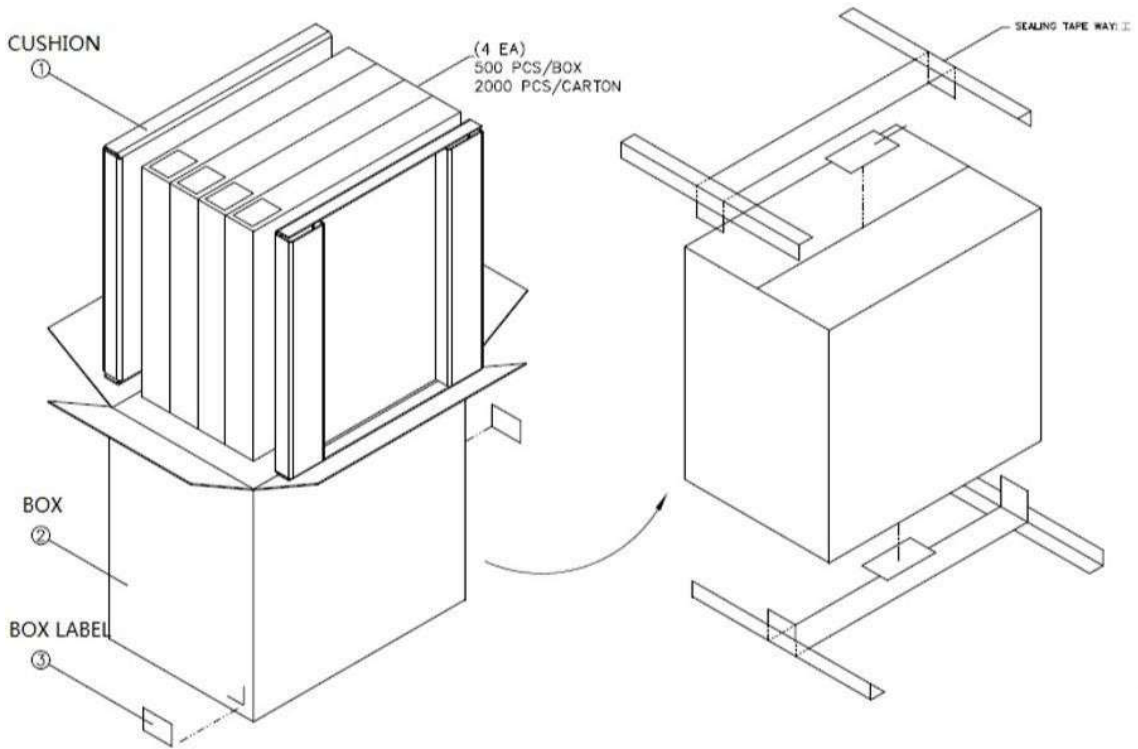
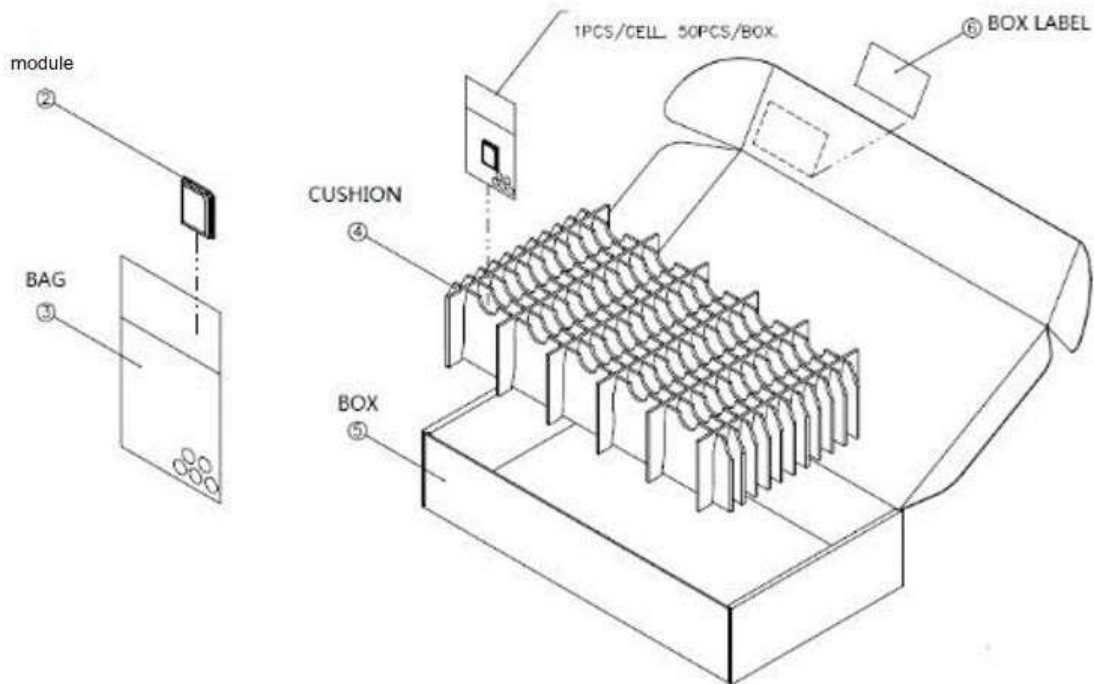

Figure 29. Packing—carton

## 8.2. Single Packaging for Samples

Samples are packaged at 50 pcs. /box. There is no vacuum packaging. Samples must be baked for 8 hours at least at 85 °C before SMT.



## 8.3. MSL level

The module MSL level is 3.

## 9. Safety Recommendation

Be sure the use of this product is allowed in the country and in the environment required.

The use of this product may be dangerous and must be avoided in the following areas:

- Where it can interfere with other electronic devices in environments such as hospitals, airports, and aircraft
- Where there is a risk of explosion such as gasoline stations and oil refineries

It is the responsibility of the user to comply with his or her country's regulations and the specific environmental regulations.

Do not disassemble the product; any mark of tampering will compromise the warranty's validity.

We recommend following the instructions of the hardware user guides for a correct wiring of the product. The product must be supplied with a stabilized voltage source, and the wiring must conform to the security and fire-prevention regulations.

This product must be handled with care; avoid any contact with the pins because electrostatic discharge may damage the product. Same caution must be taken regarding the UIM card; carefully check the instructions for its use. Do not insert or remove the UIM when the product is in power-saving mode.

The system integrator is responsible of the functioning of the final product; therefore, care must be taken for the external components of the module as well as for project or installation issues—there may be a risk of disturbing the GSM network or external devices or of having an impact on device security. If you have any doubts, please refer to the technical documentation and the relevant regulations in force.

Every module must be equipped with a proper antenna with specific characteristics. The antenna must be installed with care in order to avoid any interference with other electronic devices.

## 10. Warning

### FEDERAL COMMUNICATIONS COMMISSION INTERFERENCE STATEMENT

This equipment has been tested and found to comply with the limits for a Class B digital device, pursuant to part 15 of the FCC Rules. These limits are designed to provide reasonable protection against harmful interference in a residential installation. This equipment generates, uses and can radiate radio frequency energy and, if not installed and used in accordance with the instructions, may cause harmful interference to radio communications. However, there is no guarantee that interference will not occur in a particular installation. If this equipment does cause harmful interference to radio or television reception, which can be determined by turning the equipment off and on, the user is encouraged to try to correct the interference by one or more of the following measures:

- Reorient or relocate the receiving antenna.
- Increase the separation between the equipment and receiver.
- Connect the equipment into an outlet on a circuit different from that to which the receiver is connected.
- Consult the dealer or an experienced radio/ TV technician for help.

### CAUTION:

Any changes or modifications not expressly approved by the grantee of this device could void the user's authority to operate the equipment.

This device complies with Part 15 of the FCC Rules. Operation is subject to the following two conditions: (1) this device may not cause harmful interference, and (2) this device must accept any interference received, including interference that may cause undesired operation.

This module is intended for OEM integrator. The OEM integrator is responsible for the compliance to all the rules that apply to the product into which this certified RF module is integrated. Additional testing and certification may be necessary when multiple modules are used.

**USERS MANUAL OF THE END PRODUCT:**

In the user's manual of the end product, the end user has to be informed to keep at least 20cm separation with the antenna while this end product is installed and operated.

The end user has to be informed that the FCC radio-frequency exposure guidelines for an uncontrolled environment can be satisfied.

The end user has to also be informed that any changes or modifications not expressly approved by the manufacturer could void the user's authority to operate this equipment.

Operation is subject to the following two conditions: (1) this device may not cause harmful interference and (2) this device must accept any interference received, including interference that may cause undesired operation.

**LABEL OF THE END PRODUCT:**

The final end product must be labeled in a visible area with the following " Contains TX FCC ID: NKRIMQ8F4 ".

**RF Exposure warning**

This equipment must be installed and operated in accordance with provided instructions and the antenna(s) used for this transmitter must be installed to provide a separation distance of at least 20 cm from all persons and must not be co-located or operating in conjunction with any other antenna or transmitter. End-users and installers must be provide with antenna installation instructions and transmitter operating conditions for satisfying RF exposure compliance.

**Canada, Industry Canada (IC) Notices**

This device contains licence-exempt transmitter(s)/receiver(s) that comply with Innovation, Science and Economic Development Canada's licence-exempt RSS(s). Operation is subject to the following two conditions:

1. This device may not cause interference.
2. This device must accept any interference, including interference that may cause undesired operation of the device.

**Canada, avis d'Industry Canada (IC)**

Cet appareil contient un ou des émetteurs/récepteurs exempts de licence conformes aux RSS exempts de licence d'Innovation, Sciences et Développement économique Canada. Le fonctionnement est soumis aux deux conditions suivantes:

1. Cet appareil ne doit pas causer d'interférences.
2. Cet appareil doit accepter toutes les interférences, y compris les interférences pouvant entraîner un fonctionnement indésirable de l'appareil.

**Radio Frequency (RF) Exposure Information**

The radiated output power of the Wireless Device is below the Innovation, Science and Economic Development Canada (ISED) radio frequency exposure limits. The Wireless Device should be used in such a manner such that the potential for human contact during normal operation is minimized.

This device has also been evaluated and shown compliant with the IC RF Exposure limits under mobile exposure conditions. (Antennas are greater than 20cm from a person's body).

**Informations concernant l'exposition aux fréquences radio (RF)**

La puissance de sortie rayonnée de l'appareil sans fil est inférieure aux limites d'exposition aux radiofréquences d'Innovation, Sciences et Développement économique Canada (ISDE). L'Appareil sans fil doit être utilisé de telle manière que le potentiel de contact humain pendant le fonctionnement normal soit minimisé.

Cet appareil a également été évalué et démontré conforme aux limites d'exposition RF IC dans des conditions d'exposition mobile. (Les antennes sont à plus de 20 cm du corps d'une personne).