

ELKAY® *With FLEXI-GUARD*®

INSTALLATION & USE MANUAL

LZO™ Series Sensor-Operated Water Coolers



Model LZO8L

Patent zurn-elkay.com/patents

⚠ **WARNING:** Cancer and Reproductive Harm - www.P65Warnings.ca.gov

⚠ **ADVERTENCIA:** Cáncer y daño reproductivo - www.P65Warnings.ca.gov

⚠ **AVERTISSEMENT:** Cancer et effets néfastes sur la reproduction - www.P65Warnings.ca.gov

Note: Danger! Electrical shock hazard. Disconnect power before servicing unit.

Uses HFC-134A refrigerant

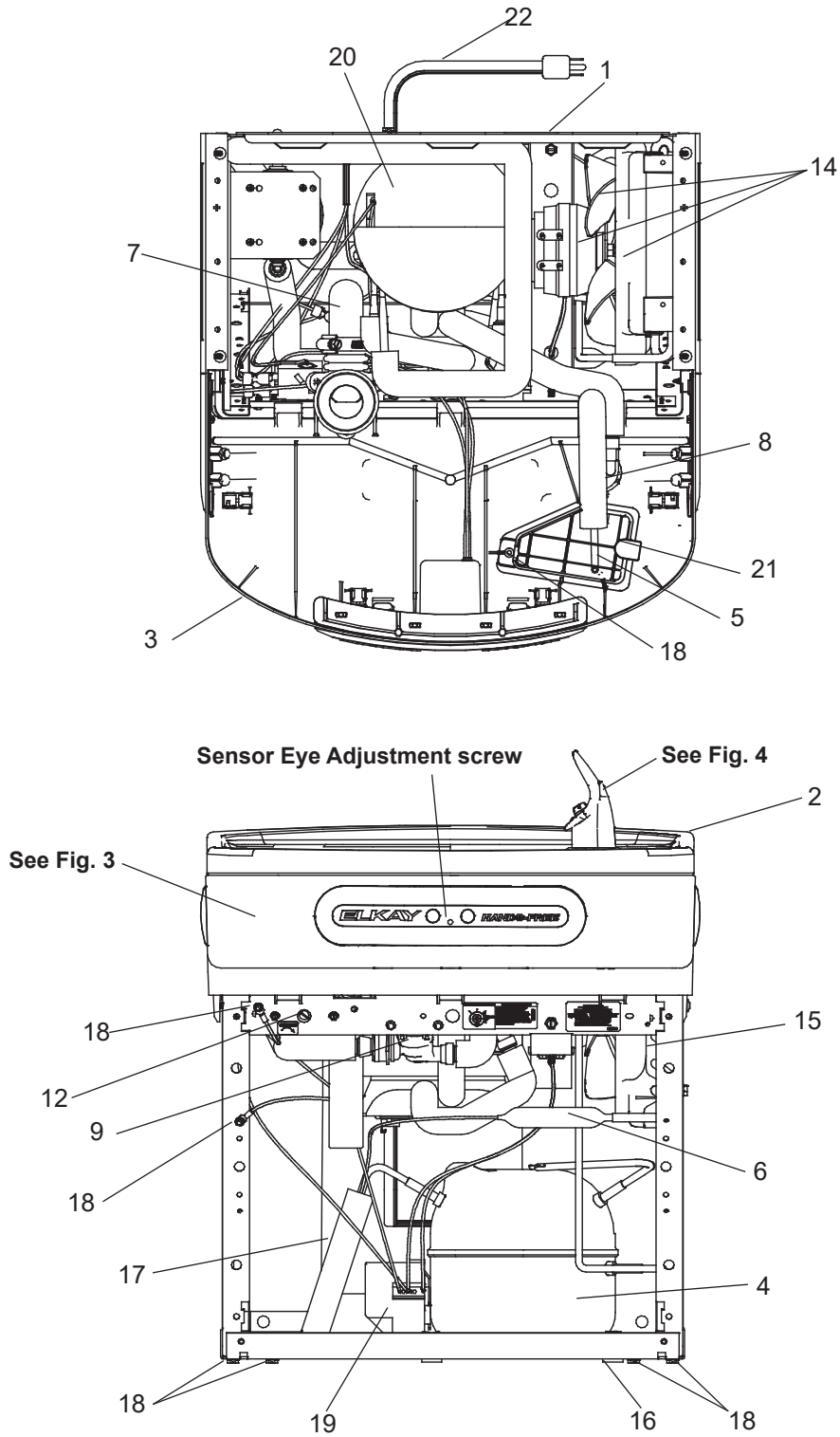
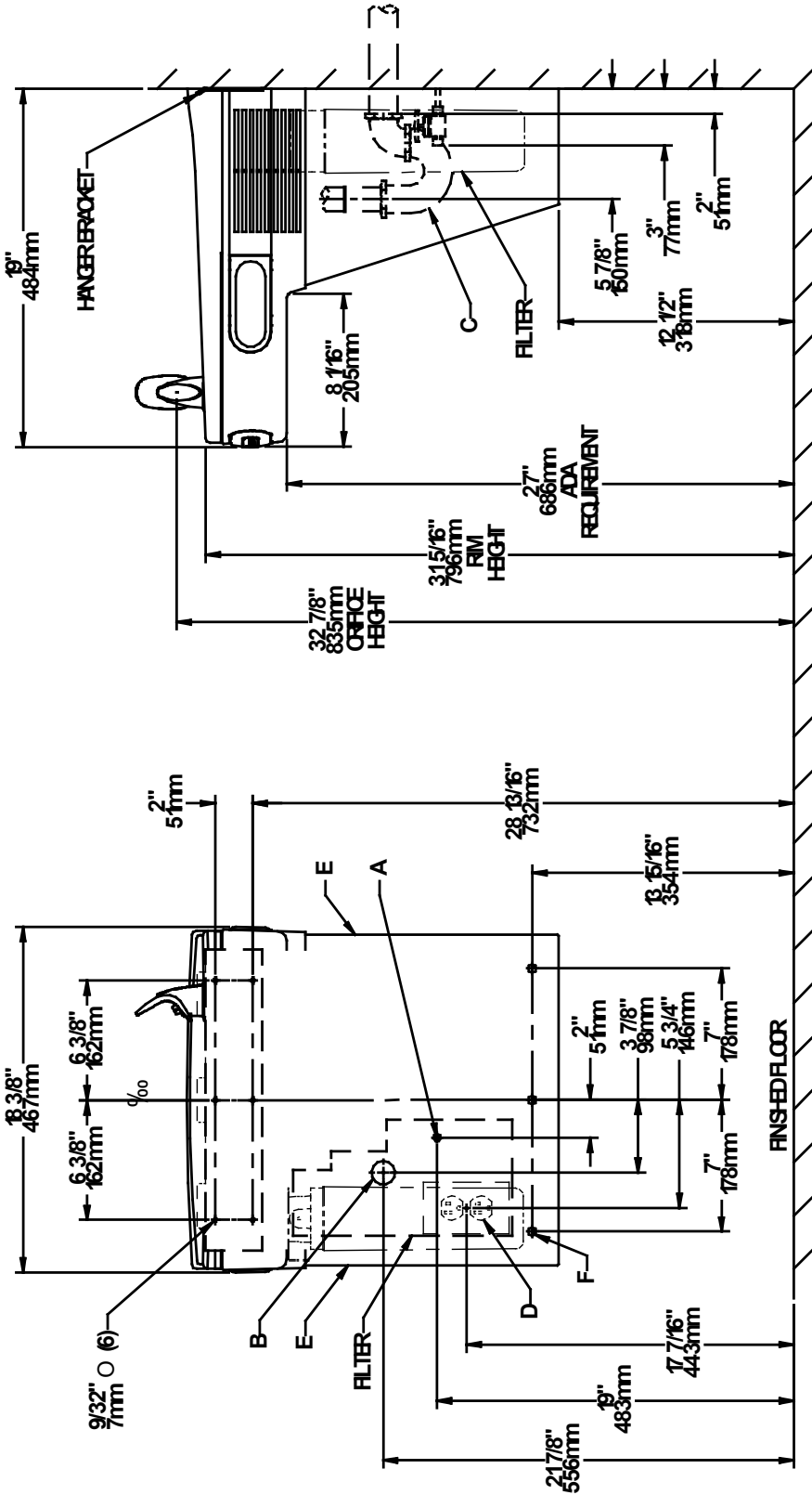

FIG. 1





REDUCE HEIGHT BY 3 INCHES FOR INSTALLATION OF CHILDREN'S ADA COOLER

- LEGEND/LEYENDA/LÉGENDE**
- A = RECOMMENDED WATER SUPPLY LOCATION 3/8" O.D. UNPLATED COPPER TUBE CONNECT STUB WITH SHUT OFF (BY OTHERS) 3" IN. (76mm) MAXIMUM OUT FROM WALL**
 La UBICACION 3/8 O RECOMENDADA de ABASTECIMIENTO DE AGUA. D. El TUBO del COBRE de UNPLATED CONECTA TALONARIO CON APAGO (POR OTROS) 3 en. (76 Mm) el MAXIMO FUERA DE PARED
 - MAXIMUM WATER SUPPLY PRESSURE: 105 PSI (0.73 MPa)**
 PRESION MAXIMA DE SUMINISTRO DE AGUA: 105 PSI (0.73 MPa)
 - L.O.D de 3/8 d'EMPLACEMENT DE PROVISION D'EAU RECOMMANDE. LE TUBE DE CUIVRE DE UNPLATED CONNECTE STUB AVEC ETEINT (PAR LES AUTRES) 3 dans. (76 mm) le MAXIMUM HORS DU MUR**
 PRESION MAXIMALE D'ALIMENTATION EN EAU: 105 PSI (0.73 MPa)
 - B = RECOMMENDED LOCATION FOR WASTE OUTLET 1-1/4" O.D. DRAIN STUB 2" OUT FROM WALL**
 UBICACION RECOMENDADA PARA EL DRENAJE DE SALIDA DE AGUA, DE 1 1/2" DE DIAMETRO. El TALONARIO 2 FUERA DE PARED
 - EMPLACEMENT RECOMMANDE POUR LE DRAIN DE D.E. 1-1/4" D'ORTIE D'EAU. STUB 2 HORS DU MUR**
 PURGADOR DE 1 1/4" NO PROPORCIONADO
 - SIPHON 1-1/4 NON FOURNI**
 - D = ELECTRICAL SUPPLY (3) WIRE RECESSED BOX**
 CAJA RECESIVA DE ALAMBRES (3) DE SUMINISTRO ELECTRICO
 - E = INSURE PROPER VENTILATION BY MAINTAINING 6" (152 mm) (MIN.) CLEARANCE FROM CABINET LOUVERS TO WALL**
 BOITE ENCASTREE D'ALIMENTATION ELECTRIQUE (3) FILS
 - ASEGURE UNA VENTILACION ADECUADA MANTENIENDO UN ESPACIO E 6" (152 mm) (MIN.) DE HOLGURA ENTRE LA REJILLA DE VENTILACION DEL MUEBLE Y LA PARED**
 - F = 7/16" BOLT HOLES FOR FASTENING UNIT TO WALL**
 AGUJEROS DE LAS TUERCAS DE 7/16 PARA SUJETAR LA UNIDAD A LA PARED
 - AGUJEROS DE LAS TUERCAS DE 7/16 PARA SUJETAR LA UNIDAD A LA PARED**
 - **NEW INSTALLATIONS MUST USE GROUND FAULT CIRCUIT INTERRUPTERS (GFCI)**
 - **LAS NUEVAS INSTALACIONES DEBEN UTILIZAR LOS INTERRUPTORES DE CIRCUITO DE TIERRA DE LA AVERIA (GFCI)**
 - **LES NOUVELLES INSTALLATIONS DOIVENT EMPLOYER LES INTERRUPTEURS DE CIRCUIT MOULVS DE DEFALT (GFCI)**

FIG. 2



HANGER BRACKETS & TRAP INSTALLATION

- 1) Remove hanger bracket fastened to back of cooler by removing one (1) screw.
- 2) Mount the hanger bracket as shown in Fig. 2.

NOTE: Hanger Bracket **MUST** be supported securely. Add fixture support carrier if wall will not provide adequate support. Anchor hanger securely to wall using all six (6) 1/4 in. dia. mounting holes.

INSTALLATION OF COOLER

- 3) Hang the cooler on the hanger bracket. Be certain the hanger bracket is engaged properly in the slots on the cooler back as shown in Fig. 2.
- 4) Remove the four (4) screws holding the lower front panel at the bottom of cooler. Remove the front panel by pulling straight down and set aside.
- 5) Connect water inlet line--See Note 4 of General Instructions.
- 6) Install trap. Remove the slip nut and gasket from the trap and install them on the cooler waste line making sure that the end of the waste line fits into the trap. Assemble the slip nut and gasket to the trap and tighten securely.

IMPORTANT: If it is necessary to cut the drain, loosen the screw at the black rubber boot and remove tube, check for leaks after re-assembly.

- 7) Plug in electrical power. Unit must have electrical power to have water flow.

START UP

Also See General Instructions

- 8) Stream height is factory set at 35 PSI. If supply pressure varies greatly from this, adjust screw located on the right knee clearance area of the underside of the Basin Shroud. CW adjustment will raise stream and CCW adjustment will lower stream. For best adjustment, stream should hit basin approximately 6-1/2" (165mm) from bubbler on the downward slope of the basin.

NOTE: If continuous flow occurs at the end of the compressor cycle, turn cold control counterclockwise 1/4 turn.

- 9) Replace the front panel ensuring that the metal wrapper is secured inside of the upper shroud. Replace all four screws previously removed.

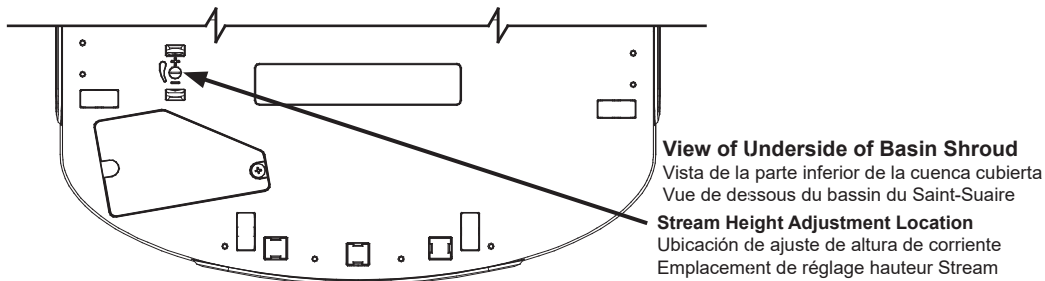

SENSOR RANGE ADJUSTMENT:

The electronic sensor used in this cooler is factory pre-set for a "visual" range of 18" to 24" (457mm to 610mm). If actual range varies greatly from this or a different setting is desired, follow the range adjustment procedure below:

- Using a small tip screwdriver, locate range adjustment screw through the small hole between the sensor lenses (See Page 1.)
Turn this screw clockwise to increase range and counterclockwise to decrease range (See Fig. 3).

CAUTION: Complete range of sensor is only one turn of the adjusting screw.

SENSOR WITH VISUAL FILTER MONITOR (VFM) – LZO SERIES:

The electronic sensor includes LED filter status indicators that are factory preset to monitor filter life. The sensor monitors the "ON" time of the water valve solenoid and keeps track of total time water is dispensed. There are (3) LED's and indicates the following:

Green LED (Good) indicates that the filter is operating within 0% - 80% of its life.

Yellow LED indicates that the filter is operating within 80% - 100% of its life.

Red LED (Replace) indicates that the filter needs to be replaced since it has reached end of filter life.

Once power is applied to the water cooler, if all three LED's flash then the Green LED illuminates, this indicates that there is some filter usage memory stored. When the Green LED comes on only, this indicates that the filter life is at absolute 0% of filter life. NOTE: You may have some very minimal filter life in memory upon receiving water cooler due to factory functional testing.

NOTE: The filter status will be retained until reset (see resetting filter monitor). The filter monitor will retain its memory even during a loss of power.

RESETTING VISUAL FILTER MONITOR (VFM):

In order to reset the visual filter monitor status LED's, you must remove the access panel (item 21) underneath the front dispenser. With your finger or straight blade screw driver, reach inside opening and depress the reset button located on the back of the sensor for a minimum of 1 second. (You may need a flashlight) Reinstall access panel and the Green LED should be illuminated indicating that the visual filter monitor has been reset.

SENSOR CONTROL: If sensor fails to operate valve mechanism or operates erratically, check the following.

- A. Ensure there are no obstructions within a 40 inch (1016mm) radius in front of cooler.
- B. Check wire connections at the solenoid valve and sensor. **CAUTION:** Make sure unit is unplugged before checking any wiring.
- C. Ensure proper operation of solenoid valve. If there is an audible clicking sound yet no water flows, look for an obstruction in the valve itself or elsewhere in the water supply line.

CLEANING

Warm, soapy water or mild household cleaning products can be used to clean the exterior panels of the EZ coolers. Extra caution should be used to clean the mirror finished stainless steel panels. They can be easily scratched and should only be cleaned with mild soap and water or Windex glass cleaner and a clean, soft cloth. Use of harsh chemicals or petroleum based or abrasive cleaners **will void the warranty.**

Note: Danger! Electrical shock hazard. Disconnect power before servicing unit.

Service Instructions

Lower and Upper Shroud

To access the refrigeration system and plumbing connections, remove four screws from bottom of cooler to remove the lower shroud. To remove the upper shroud for access to the pushbars, regulator, solenoid valve or other components located in the top of the unit, remove lower shroud, disconnect drain, remove four screws from tabs along lower edge of upper shroud, unplug two wires and water tube.

Bubbler

To remove the bubbler, first disconnect the power supply. The underside of the bubbler can be reached through the access panel (Item 21, Page 2) on the underside of the shroud (Item 3). Remove the access panel by removing the retaining screw. To remove the bubbler, loosen locknut from the underside of the bubbler and remove the tubing from the quick connect fitting per the Operation Of Quick Connect Fittings section in the General Instructions. After servicing, replace the access panel and retaining screw.

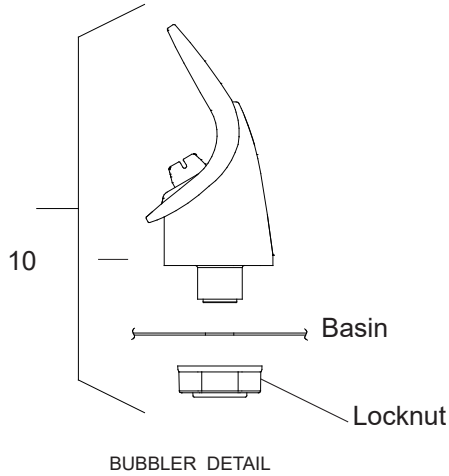

FIG. 4

NOTE:

When installing replacement bubbler and pedestal, tighten locknut only to hold parts snug in position. Do Not Overtighten.

Filter Detail

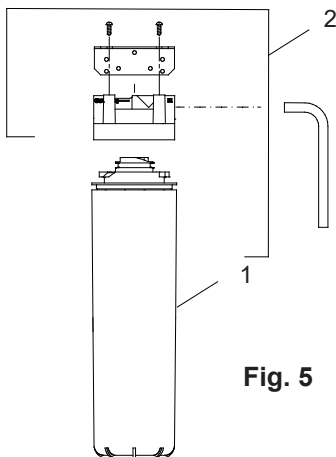

Fig. 5

FILTER PARTS LIST		
ITEM NO.	PART NO.	DESCRIPTION
1	51299C	Filter Assy-1500 Gal. Assy-Filter & Bracket
2	000000746	includes Filtr Head/Mtg Bkt/ John Guest Ftgs/Screws

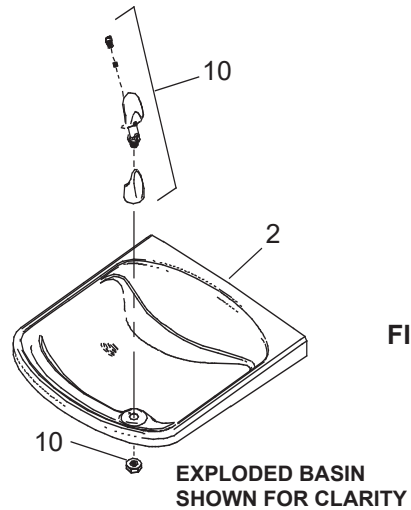
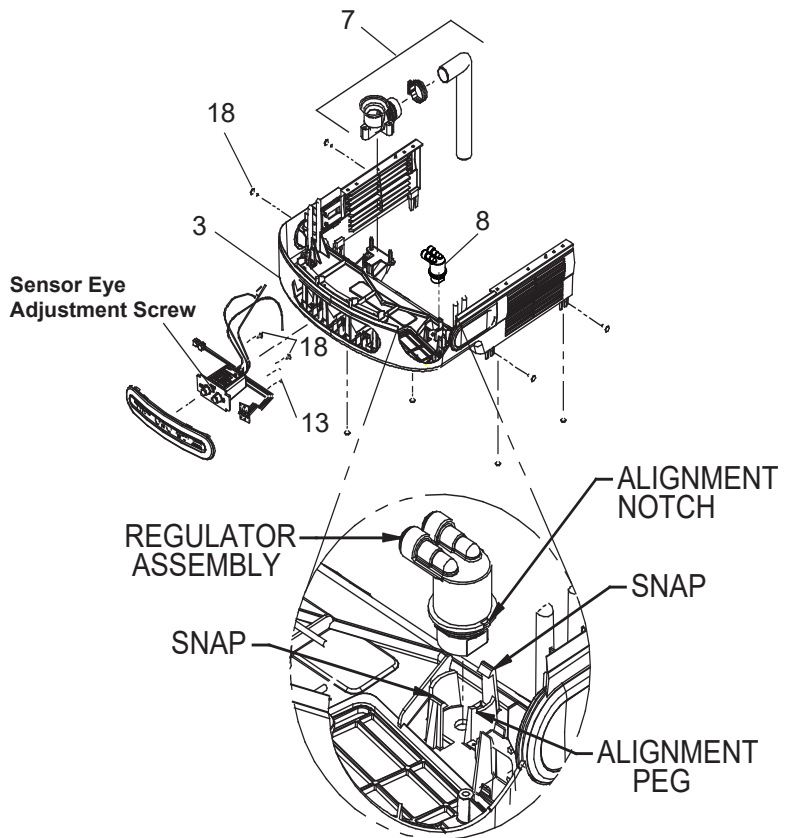

FIG. 3



Scan for troubleshooting information and to subscribe to automatic filter replacements at a discount.

115V PARTS LIST

ITEM NO.	PART NO.	DESCRIPTION
1	28401C	Hanger Bracket
2	55001109	Basin - Stainless Steel
3	2000001903	Shroud Assembly LZO
*4	36322C	Compressor Serv. Pak
5	56092C	Poly Tubing (Cut to Length)
6	66703C	Drier
7	97970C	Kit - Drain Replacement (EZ)(Brkt/Tube/Ftg/Clamp)
8	1000004564	Kit - Regulator w/Holder & Nut
9	1000004572	Kit - Solenoid Valve/Regulator/Nut Assy.
10	56073C	Kit - Bubbler Assy/Nut
11	30873C	Wire - Jumper
12	98773C	Kit - Cold Control/Screws
13	75710C	2-28 x .250 48-2 Plastite Screw
14	98775C	Kit - Fan Motor Assy/Blade/Motor/Shroud/Screws/Nut
15	98776C	Kit - Condenser/Drier
16	98777C	Kit - Compr Mtg Hdwe/Grommets/Clips/Studs
17	98778C	Kit - Heatx/Drier
18	98898C	Kit - Hardware (EZ) for Panels
19	0000000238	Kit - Compr Elect Relay/Overload/Cover
20	98724C	Kit - Evaporator Replacement Assy.
21	56213C	Panel - Access
22	36287C	Power Cord (Refrig. Unit)
NS	1000006146	Power Cord (Less Refrig. Unit)
	27416C	Kit - Wrapper - Stainless
	27413C	Kit - Wrapper - Light Grey

NS = Not Shown

***INCLUDES RELAY & OVERLOAD. IF UNDER WARRANTY, REPLACE WITH SAME COMPRESSOR USED IN ORIGINAL ASSEMBLY.**

NOTE: All correspondence pertaining to any of the above water coolers or orders for repair parts MUST include Model No. and Serial No. of cooler, name and part number of replacement part.

220V PARTS LIST

ITEM NO.	PART NO.	DESCRIPTION
*3	1000002147	Compressor Serv. Pak (220V/50Hz)
	1000002146	Compressor Serv. Pak (220V/60Hz)
9	1000004575	Kit - Solenoid Valve/Reg./Nut Assy.
14	0000000245	Kit - Fan Motor/Blade (220V 50Hz-60Hz)
19	98751C	Kit - Overload/Relay/Cover (220V/50Hz)
	98752C	Kit - Overload/Relay/Cover (220V/60Hz)
22	36066C	Power Cord
23	33133000	Adapt - Tab .250
NS	28030C	Brkt - Power Inlet
NS	35826C	Inlet Power

NS = Not Shown

WIRING DIAGRAM - LZO 115V
FIG. 7

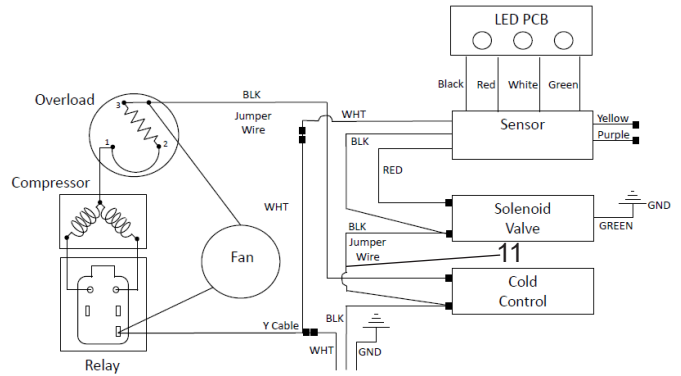

WIRING DIAGRAM - LZO 220V
FIG. 8

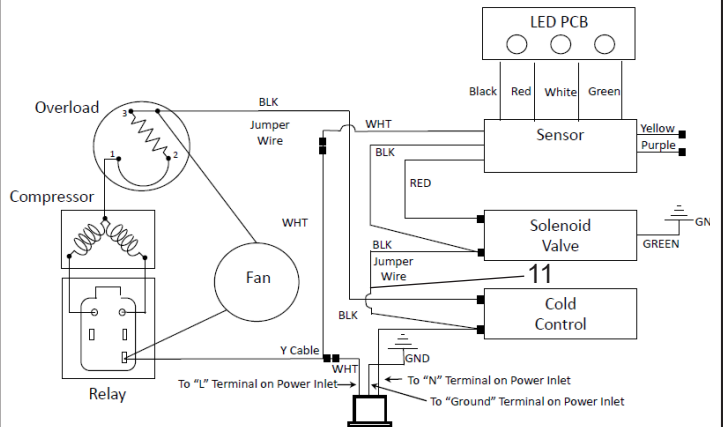

FOR PARTS, CONTACT YOUR LOCAL DISTRIBUTOR OR CALL 1.800.834.4816

REPAIR SERVICE INFORMATION TOLL FREE NUMBER 1.800.260.6640

ELKAY MANUFACTURING COMPANY • 1333 BUTTERFIELD ROAD, SUITE 200 • DOWNERS GROVE, IL 60515 • 630.574.8484 • www.elkay.com

