



Etherstack Pty Ltd
64 Rose Street
Chippendale
NSW 2008
AUSTRALIA
Email: info-au@etherstack.com
P: +61 2 8399 7500
F: +61 2 8399 7507

Etherstack XBR5100

Fully Integrated P25 Base-Station

Technical Manual

Document Version: **1.04**

Document ID: **ES2202-UM01**

Author: Etherstack
Created: 05 June, 2025
Last Updated: 06 January, 2026
Last Updated by: Etherstack

Copyright © Etherstack Pty Ltd 2026

This is the confidential proprietary property of Etherstack Pty Ltd. This document is protected by copyright. No part of it may be reproduced or copied without the prior written permission of Etherstack Pty Ltd. Etherstack Pty Ltd products are supplied under licence and may be used only in accordance with the terms of the contractual agreement between Etherstack Pty Ltd and the licence holder. All products, brand names and trademarks referred to in this publication are the property of Etherstack Pty Ltd or third-party owners. Unauthorised use may constitute an infringement. Etherstack Pty Ltd reserves the right to change information contained in this publication without notice. All efforts have been made to ensure accuracy however Etherstack Pty Ltd does not assume responsibility for errors or for any consequences arising from errors in this publication.



Copyright

Etherstack Pty Ltd

ARBN 156 640 532

64 Rose Street

Chippendale

NSW 2008

Australia

Ph: +61 (0)2 8399 7500

Fax: +61 (0)2 8399 7507

info-au@etherstack.com

www.etherstack.com

Etherstack reserves the right to alter, without notice and at any time, the equipment and specifications described in this document. All performance figures quoted are typical and are subject to normal manufacturing and service tolerances.

The purchaser is advised that some statements made in this document may be inaccurate due to typographical or other errors or subsequent modifications of the product. While every care has been taken in the creation of this document, no warranty of accuracy or reliability is given, in any advice or information contained in this document. Etherstack Pty Ltd or any director, officer, agent, or employee of Etherstack Pty Ltd cannot be held liable for any loss or damage whatsoever arising in any way or any representation, act or omission whether express or implied (including responsibility to any person by reason of negligence).

Copyright © Etherstack Pty Ltd 2026

This work is copyright. Other than as permitted by Law, no part of it may be reproduced, stored in a retrieval system, or transmitted in any form or by any process without prior written permission.

Regulatory Information

FCC Compliance

This device complies with part 15 of the FCC Rules. Operation is subject to the following two conditions:

- (1) This device may not cause harmful interference, and
- (2) This device must accept any interference received, including interference that may cause undesired operation.

FCC Interference Warning

Note: This equipment generates, uses, and can radiate radio frequency energy. If not installed and used in accordance with this instruction manual, it may cause harmful interference to other radio communications. Harmful interference is any emission, radiation or induction that endangers the functioning of a radio navigation service or of other safety services or seriously degrades, obstructs, or repeatedly interrupts a radio communications service operating in accordance CFR Title 47 Part 15.

INDUSTRY CANADA COMPLIANCE (ISED)

This device complies with Industry Canada license-exempt RSS standard(s). Operation is subject to the following two conditions: (1) this device may not cause interference, and (2) this device must accept any interference, including interference that may cause undesired operation of the device.

FRENCH: Le présent appareil est conforme aux CNR d'Industrie Canada applicables aux appareils radio exempts de licence. L'exploitation est autorisée aux deux conditions suivantes : (1) l'appareil ne doit pas produire de brouillage, et (2) l'utilisateur de l'appareil doit accepter tout brouillage radioélectrique subi, même si le brouillage est susceptible d'en compromettre le fonctionnement.

HUMAN EXPOSURE TO RADIO FREQUENCY RADIATION

USA Customers - Warning to comply with the maximum permissible exposure (MPE) limits referenced in 47 CFR 1.1310, the following minimum safe operating distances must be observed:

MODEL(s)/FCC ID	FREQ. RANGE OPERATION	SAFE OPERATING DISTANCES*1	Measurement Reference*2
XBR5100P5VI / 2ADAKXBR5100P5VI	450-520 MHz	2.567 m	120 watts at 450MHz
XBR5100D5HI / 2ADAKXBR5100D5HI	136-174MHz	2.223 m	60 watts at 136MHz
XBR5100D5VI / 2ADAKXBR5100D5VI	136-174MHz	3.144 m	120 watts at 136MHz
XBR5110D5VI / 2ADAKXBR5110D5VI	136-174MHz	3.144 m	120 watts at 136MHz
XBR5100T5VI / 2ADAKXBR5100T5VI	763-776 MHz 850-870 MHz	1.971 m	120 watts at 763MHz



Canada Customers - The XBR5100 radio transmitter has been approved by Innovation, Science and Economic Development Canada to operate with the maximum permissible exposure (MPE) limits defined in Radio Communication Apparatus (All Frequency Bands) , RSS-102, Issue 6. The following minimum safe operating distances must be observed:

MODEL(s)/ISED ID	FREQ. RANGE OPERATION	SAFE OPERATING DISTANCES*1	Measurement Reference*2
XBR5100P5VI / 9487A-XBR5100P5VI	450-520 MHz	3.407 m	120 watts at 450MHz
XBR5100D5HI / 9487A-XBR5100D5HI	136-174MHz	2.767 m	60 watts at 136MHz
XBR5100D5VI / 9487A-XBR5100D5VI	136-174MHz	3.913 m	120 watts at 136MHz
XBR5110D5VI / 9487A-XBR5110D5VI	136-174MHz	3.913 m	120 watts at 136MHz
XBR5100T5VI / 9487A-XBR5100T5VI	763-776 MHz 850-870 MHz	2.844 m	120 watts at 763MHz

*1 The distance measured from the transmitter antenna. The transmitter antenna(s) must be fixed-mounted on outdoor permanent structures.

Distance calculations based on folded dipole typ. gain 3.16dBi

*2 Reference power is based on 120% of rated maximum TX Power as per 90.205(s) FCC Power limit.



Change Record

Date	Version	Chapter Changes	Pages Changed
09 June 2025	1.00	All Initial Release for UHF High (100W)	All
12 June 2025	1.01	Added Safe Operating Distance for D5HI variant	3, 4
05 August 2025	1.02	Added description of XBR5110D5VI, T5VI, N5VI variants	3, 4
25 September 2025	1.03	Minimum safe operating distance calculation based on 120% of rated power Amended error of RSS-102 Issue number	3, 4
06 January 2026	1.04	Added description of XBR5100D5VI variant Removed tentative description of XBR5100N5VI variant	3, 4

Warranty & Safety

Safety Summary

The XBR5100 does not contain a power supply with dangerous mains voltages. Normal operation and use of the XBR5100 does not expose the operator or service technician to high voltage parts but could produce high electric power output up to 100W which could be hazardous and dangerous. For servicing, please return to your nearest Etherstack distributor. No fuses or user-serviceable parts are contained within the appliance.

The following general safety precautions as would normally apply, should be observed during all phases of operation, service, and repair of this equipment.

AROUND THE EQUIPMENT

To minimise any possible shock hazard from an external power supply or lightning strike, the chassis or equipment cabinet must be connected to an electrical ground. Provide adequate ventilation around the rear of the equipment.

DO NOT OPERATE IN AN EXPLOSIVE ATMOSPHERE

Do not operate the equipment in the presence of flammable gases or fumes. Operation of any electrical equipment in such an environment constitutes a definite safety hazard.

DO NOT ATTEMPT INTERNAL SERVICE

Thermal or RF burns may result from touching certain components within the power amplifier module while operating the transmitter.

DO NOT SUBSTITUTE PARTS OR MODIFY THE EQUIPMENT

Because of the danger of introducing additional hazards, do not substitute parts or modify the equipment. Return to your authorised distributor.

Any modifications you make to this equipment which are not authorised by Etherstack may invalidate your compliance authority's approval to operate the equipment.

EXERCISE CAUTION AND CORRECT DISPOSAL OF RF POWER DEVICES

Most RF power transistors and some RF power hybrids contain Beryllium Oxide. Although they are normally safe, if physically damaged toxic dust may be released. Consult your local authority for correct disposal thereof. Such devices are not normally used in the XBR5100.

Warranty Conditions & Precautions

The following conditions are not covered by the warranty of the XBR5100. Please ensure that the XBR5100 is not subject to:

1. Over voltage or Reverse Power Supply Voltage.
2. Operation in locations subject to abnormal environmental conditions such as extreme temperatures or ingress of moisture or excessively dusty environments.
3. Operation of the XBR5100 Transmitter output into an open or short circuit or an incorrectly terminated load. Although a level of VSWR protection is included, greater protection is provided by the addition of a TX RF isolator.

Contents

1 Product Description.....	8
1.1 Overview	8
1.2 Physical Attributes	8
1.2.1 Front Panel.....	9
1.2.2 Front Panel LEDs	9
1.2.3 Rear Panel	10
1.3 XB5100 Internal Modules.....	10
1.3.1 Exciter Module.....	11
1.3.2 Receiver Module.....	11
1.3.3 Radio Controller Module.....	11
1.3.4 Power Amplifier Module.....	11
1.3.5 XBR Controller Module.....	11
1.3.6 Application Module	11
2 Installation & Operation.....	12
2.1 Installation	12
2.2 Screw Head Types	12
2.3 Operation.....	13
2.3.1 Setting to Work.....	13
2.3.2 Adjustments.....	13
3 Alignment & Testing.....	14
4 Power	15
4.1 DC Input Pinouts.....	15
5 Specifications.....	16
5.1 Operating Frequency Bands	16
5.2 General.....	16
5.3 Transmit	17
5.4 Receive	17
5.5 Ancillaries	17
5.6 XBR5100 Model Number Configuration Guide.....	17

1 Product Description

1.1 Overview

The XBR5100 is a full-functionality standards-compliant P25 Phase 1 base station that is compatible with existing Etherstack infrastructure including Etherstack P25 digital cores, and Etherstack P25 Channel Controller connected base stations. It can be used both stand alone or as part of a larger P25 network including single site, multi-site, voted and simulcast configurations. It is a highly configurable product that is well suited to remote deployment comprising fault-tolerant / redundant architectures with comprehensive remote management tools and low maintenance intervals.

The Receiver and Exciter circuits are contained within a single special aluminium housing together with the associated audio processing and digital control on a single circuit board. The Power Amplifier is also enclosed in an extruded aluminium housing. The XBR5100 also incorporates 'Plug and Play' technology and performs automatic self-calibration. A complete module changeover can be performed in the field in a very short time, by appropriately trained and authorised service personnel.

The XBR5100 employs some unique features in its design and much thought and consultation has been used to provide a product that offers an extreme degree of flexibility for the installer, service person and operator. For example, all options may be easily field retrofitted at a later date.

The flexibility of the XBR5100 series base station allows it to be configured for a wide range of applications without removing the cover.

The XBR5100 incorporates special technical features, a number of which are listed below:

- Extremely low conducted emissions
- Extremely low transmitter spurious emissions
- Fast transmitter on time
- Analogue FM (Narrow, Wide) 50W RF (100W option)
For the US version, analogue Wide FM Mode can be turned off
- Digital APCO P25 Conventional, Trunking repeater
- Mixed mode operation (automatic switch between analogue and P25 modes)
- P25 Data
- Simplex, Repeat operation
- DFSI support
- Programmable CTCSS, CDCSS and NAC
- Pre-emphasis ON/OFF & De-emphasis ON/OFF Function
- CWID support
- Per channel power setting
- Trunking via BSC (option)
- Simulcast & Voting (option)
- SNMPv3 support
- Remotely programmable and upgradable

1.2 Physical Attributes

The XBR5100 is a compact lightweight standard 19" rack mounting transceiver and channel controller. It is designed to mount horizontally in a 19" standard rack frame and occupies 2RU (89mm). The depth

of the unit is 330mm and the weight is less than 8kg.

The unit consists of four main sub-assemblies, the main RF assembly, a Power Amplifier Module, Application Module and the XBR Controller. These modules are housed in a sturdy steel case.

The XBR5100 features a high degree of RFI and EMI screening throughout the design and construction. The receiver and exciter RF circuits are contained within a solid aluminium enclosure. The PA module is enclosed in a special compact and efficient extrusion for minimum harmonic radiation. This design results in low conducted and radiated emissions and minimal susceptibility to RFI and EMI.

The rear panel features various connections including DC power in, DB25 (I/O interface), USB (service interface) and dual RJ45 (Ethernet LAN interface).

1.2.1 Front Panel

The XBR5100 front panel provides the user with the real time status of the XBR5100.



1.2.2 Front Panel LEDs

The table below explains the functions of the front panel LEDs. Each LED indicates the status of the XBR5100 in real time.

LED	COLOR	STATUS
POWER	GREEN	The power supply voltage is within limits. No display indicates the supply voltage is not present or outside specified limits.
ONLINE	AMBER	The device is ready for operation when solid. Other specific state when blinking.
HA	BLUE	High Availability mode is active.
SYSTEM	YELLOW	System connection is active.
RX	AQUA	A wanted signal is being received by the receiver.
TX	RED	The transmitter is transmitting RF power.
SIMULCAST	GREEN	The transmitter is operating in simulcast mode (for simulcast ready variants only).
ALARM	RED	A preconfigured alarm condition exists.
F1	YELLOW	Reserved
F2	YELLOW	Reserved

1.2.3 Rear Panel

The XBR5100 rear panel provides the user with all functional connections as well as the passive heatsink and active cooling fan.



	Connector Type	Function	Description
1	GX25 Style Power Connector	DC Power input	13.8V DC power input. 28V DC power input (For T5 variants only)
2	N TYPE	RX input	The input to the receiver for full duplex operation.
3	N TYPE	TX output	The RF power output from the transmitter for full duplex operation.
4	BNC	Timing reference	1 PPS input (for simulcast ready variants only).
5	BNC	Frequency reference	10 MHz frequency reference input (for simulcast ready variants only).
6	RJ45	V.24 Interface	Legacy interface for interoperability with Motorola's V.24 Interface.
7	RJ45	Ethernet	First Ethernet Port (for network connection and configuration)
8	DB25	External I/O	General purpose I/O.
9	USB	USB TYPE B	Service Interface
10	RJ45	Ethernet	Second Ethernet Port (for HA)

1.3 XBR5100 Internal Modules

The XBR5100 consists of a full duplex RF module contained within a shielded metal housing and a Radio Controller board integrated on a single PCB, an XBR Controller Module and an Application Module. The XBR Controller Module is a single PCB which implements layers 1 through 3 of the air interface with its DSP and provides the interface to rear panel connectors. The Application Module is a commercial off-the-shelf (COTS) computer module mounted on the XBR Controller Module implementing advanced network functionality and a graphical user interface that controls the entire device. Using advanced yet simplified circuit designs, the size and complexity is reduced. This affords a number of advantages including;

- Cost reduction
- Improved reliability and MTBF by reducing number of components
- Consistent and improved manufacturing process
- Elimination of connectors and cabling
- Reduction of human error
- Faster maintenance or swap out

1.3.1 Exciter Module

The Exciter module generates the low level, on frequency, RF transmitter signal which is later amplified to nominal output power level by the Power Amplifier module. The exciter consists of a Voltage Controlled Oscillator (VCO) and associated main RF board, which, in conjunction with the reference oscillator and the PLL circuitry, forms a two-point modulation programmable frequency synthesiser. Frequency programming data is received from the Radio Controller.

1.3.2 Receiver Module

The receiver section accepts the low-level RF input signal and amplifies, filters and conditions the signal prior to detecting the wanted audio component. The Receiver features the same advanced synthesiser and wide bandwidth as the Exciter.

1.3.3 Radio Controller Module

The Radio Controller section is physically located towards the centre on the main board and controls all signal connections (apart from the RF connections). It controls the operation of the RF sections and acts as the interface between the user controls, indicators and the RF sub sections. Together with the VF DSP chip, processed transmit and received audio is passed to and from the Exciter and Receiver sections as well as providing all other audio signalling functions of the transceiver.

1.3.4 Power Amplifier Module

The PA receives the low-level modulated RF signal from the Exciter RF output and amplifies and filters it to final output power level. Forward and reflected power voltages are fed to the Radio Controller.

1.3.5 XBR Controller Module

The XBR Controller Module hosts the Application Module and includes a DSP that implements the analog FM and P25 air interface protocol stack. It also provides the connection to external equipment accessible from the rear panel.

1.3.6 Application Module

The Application Module is a Commercial Off-The-Shelf (COTS) computer module with network capabilities and supports high level networked features such as the eBSC and Web based graphical user interface (Web UI).

2 Installation & Operation

2.1 Installation

The XBR5100 Radio is securely packaged for transport within a cardboard box. Before unpacking the XBR5100 radio, please inspect the packaging for signs of damage and report any damage to your XBR5100 distributor.

Upon unpacking the XBR5100 radio, please ensure that all items shipped were received and report any missing items to your XBR5100 distributor.

Confirm the fan is free from obstructions, as operation of the radio will be affected if any packaging or shipping damage causes the fan to stop working.

If you intend to install the radio in an equipment, rack consult the supplier's instructions for your system. If the radio is to be used in a stand-alone configuration, ensure that it is in a secure, dry location with sufficient air space around it to allow for adequate ventilation. It is recommended that the chassis is earthed to the equipment rack.

Please refer to the product specification sheet for band specific power requirements.

2.2 Screw Head Types

Modern screws employ a wide variety of drive designs, each requiring a different type of tool to drive them. Etherstack has chosen the Pozidriv® screw head and screwdriver as the preferred screw type on all its products, sizes 1 & 2. This is because the Pozidriv system is the choice for high volume assembly operations. It provides self-centering system and excellent driving control with less operator fatigue.

It is similar to the Phillips crosshead. The differences lie in the way that the heads are machined. The Phillips head has 4 simple slots cut out of it, whereas in the case of the Pozidriv each slot is the result of two machining processes at right angles. The result of this is that the arms of the cross are parallel sided in the case of Pozidriv and tapered in the case of Phillips. The Pozidriv has four additional points of contact and does not have the rounded corners that the Phillips screwdriver has.

Phillips screwdrivers will usually work in Pozidriv screws, but Phillips screwdrivers are likely to slip or tear out the screw head when used in Pozidriv screws. It is important that you use the correct type and size screwdriver to avoid damaging the screw head.

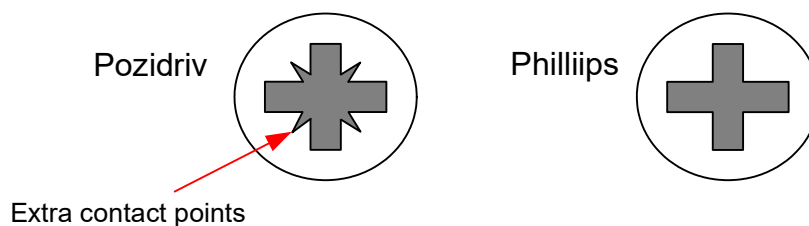

Figure 1-1 Top view of screw heads

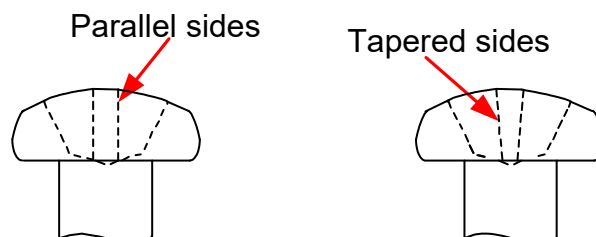

Figure 1-2 Side View of screw Heads

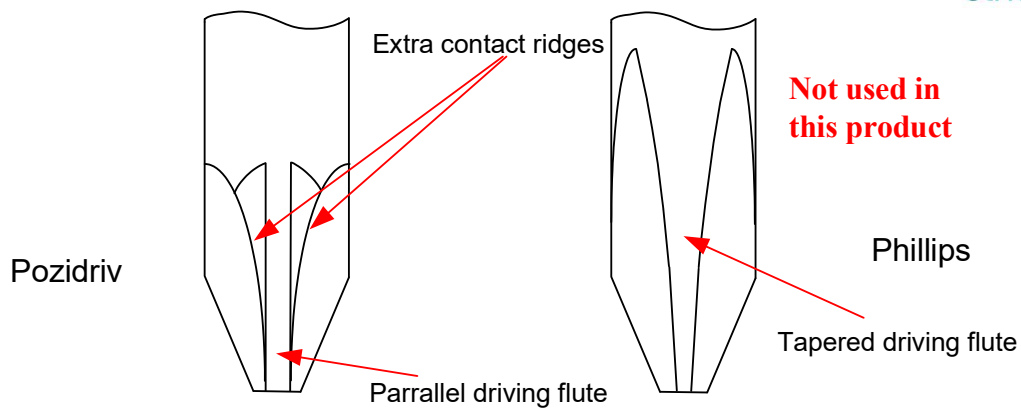

Figure 1-3 Screw driver Tip View

2.3 Operation

Setting up the XBR5100 to operate as required is straightforward and involves one main step:

- Using a PC with a web browser, connect the PC in the same local network or directly and access the Web GUI of the XBR5100. Set the appropriate parameters as required.

Note: All XBR5100s are set up with a standard default configuration that does not include any user channels. A channel must be configured before the device may be operated.

2.3.1 Setting to Work

The XBR5100 can operate in several different modes. One typical use, is as an element of a networked system.

Please refer to the Etherstack website for more details.

2.3.2 Adjustments

The XBR5100 features a number of adjustable parameters including TX power, TX VCO deviation, TX reference oscillator deviation and TX reference oscillator frequency. All of these are adjusted with the Web GUI. The XBR5100 comes pre-aligned from the factory, so in most cases no alignment will be necessary.

3 Alignment & Testing

Please refer to the Etherstack website for further details.

4 Power

The XBR5100 is powered via a 13.8V DC input on its rear panel.

4.1 DC Input Pinouts



Figure 4.1 DC INPUT Supply (GX25 Style)

PINS	Description
1	+ 28V DC (for T5 variants only)
2	GND
3	+ 13.8 V DC

5 Specifications

The XBR5100 series is designed to conform with the requirements of the following standards*:

- AS/NZS 4295
- FCC Part 90
- TIA/EIA-603
- IC (ISED)
- TIA/EIA-102 (P25 CAP)

* Conforms but not necessarily approved. Please consult Etherstack regarding current type approvals and for the latest and current XBR5100 Specification Data sheet.

5.1 Operating Frequency Bands

The XBR5100 is available in a number of models which cover a specific range of operating frequency bands. Refer to Section 5.6 for details of the band breakdown.

5.2 General

Parameter	Specification
XBR5100 Rack Size:	2RU Case
XBR5100 Overall Physical Size	89mm high, 325mm deep, 483mm wide * Requires extra depth (40mm) for Fan operation.
Weight	8 kg
Supply Voltage:	13.8V DC \pm 20%
Operating Temperature:	-30 to +60°C.
Standard LED indicators:	POWER, ONLINE, HA, SYSTEM, RX, TX, SIMULCAST and ALARM. See 1.2.2
Frequency Range:	VHF 136-174 MHz (D5) UHF 400-470 MHz (N5), 450-520 MHz (P5), 792-825 MHz (T5).
Synthesis Method:	Non mixing PLL Fractional N synthesiser.
Modulation:	C4FM, Analog wideband / narrowband
Channel Spacing:	12.5 kHz, 25kHz software selectable.
Synthesiser Step Size:	5 kHz or 6.25 kHz.
Channels:	127 Software configurable and selectable.

Table 5-1 General Specifications

5.3 Transmit

See product specification sheet.

5.4 Receive

See product specification sheet.

5.5 Ancillaries

See product specification sheet.

5.6 XBR5100 Model Number Configuration Guide

The XBR5100 build can be specified by the model number. The diagram below shows how the model number is derived from the wanted options. The “I” suffix represents that the XBR Control Module is integrated into the repeater in those models. Consult Etherstack for availability details on specific configurations and options.

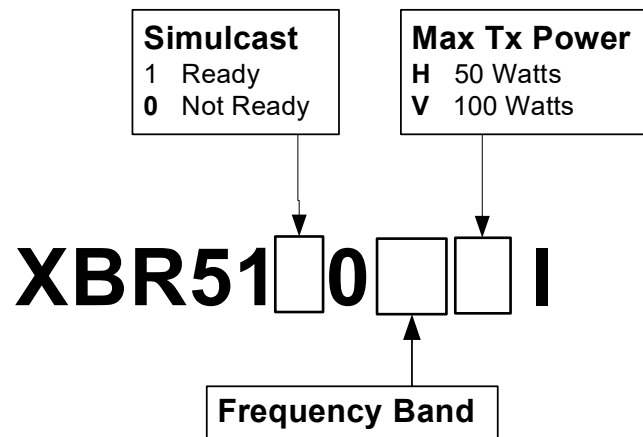

Band	Frequency
D5	VHF (136-174 MHz)
N5	UHF-Low (400-470 MHz)
P5	UHF-High (450-520 MHz)
T5	UHF 700 / 800 MHz

Table 5-2 XBR5100 frequency bands

Please refer to Etherstack website for the latest revision of the specifications.