

System 8200e THX Ultra2 and System 6200e THX Ultra2

High Performance Loudspeaker Components

Instruction Manual

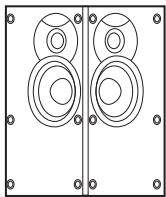

8200e SR

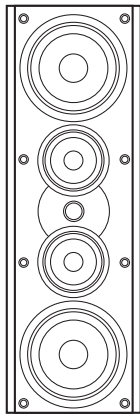

8200e LR

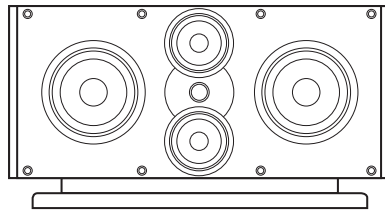

8200e C

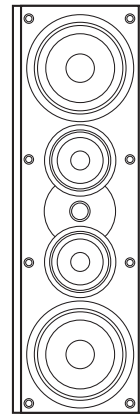

8200e LR

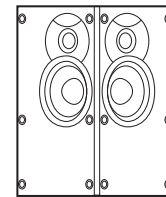

8200e SR

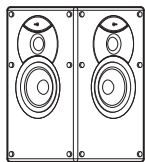

4200e SR

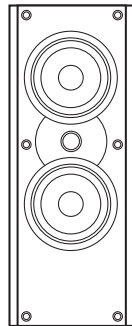

6200e LR

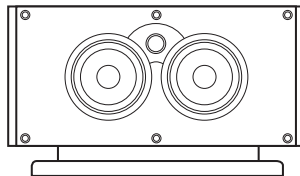

6200e C

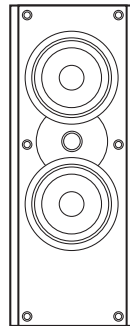

6200e LR

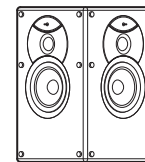

4200e SR

Atlantic
TECHNOLOGY

Table of Contents

2	Unpacking the Speakers
2	Attaching the Grilles
3	What's THX?
3	Individual Component Descriptions
3	Model 8200e LR and 6200e LR Front Channel Speakers
4	Acoustic Controls
4	Model 8200e C and 6200e C Center Channel Speakers
4	Models 8200e SR and 4200e SR Surround Speakers
4	Placement
4	Home Theater
4	Satellite Placement Using PedWoofers Under the LR Speakers
4	Surround Effects and Speaker Locations
6	6.1/7.1 Channel Systems
6	Stereo Systems
6	Connecting Your System
6	Bi-Wiring
9	System Setup
9	Bass Management
9	Operation of the Rear Panel Controls on the LCR Speakers
10	Dipole/Bipole Operation of the SR Speakers
10	Setting Levels
10	Mounting
10	Caring for Your Speakers
11	Specifications

For Future Reference

Record the serial number and date of purchase for each speaker here. The serial number is found on the speaker terminal panel on the back of the enclosure.

Serial Number	_____
Serial Number	_____
Serial Number	_____
Serial Number	_____
Serial Number	_____
Date of Purchase	_____

The contents of this manual are Copyright © 2007 by Atlantic Technology International, Corp., and may not be duplicated or reproduced by any means, whether physical, electronic or otherwise without prior written consent from Atlantic Technology International, Corp.

Atlantic Technology and the Atlantic Technology logo are registered trademarks of Atlantic Technology International, Corp.

Specifications are those in effect at the time of printing. Atlantic Technology International, Corp. reserves the right to change specifications or designs at any time without notice or obligation to modify existing units.

System 8200e THX Ultra2 and 6200e THX High Performance Loudspeaker Components

Thank you for choosing Atlantic Technology products. Your new speaker components are precision crafted to give you years of enjoyable, trouble free service. This manual covers the Atlantic Technology System 8200e and 6200e speaker components. It will show you how to incorporate these components into your present setup, as well as how to assemble a complete system from them. These systems can be used with all current and past sound formats including Stereo, Dolby Surround®, Pro Logic®, Dolby Digital 5.1®, Dolby Digital 7.1®, Dolby Digital EX®, DTS®, DTS ES®, DTS ES Discrete®, DTS Neo:6®, DVD-Audio and SACD Audio.

IMPORTANT: *Although it may seem like asking for driving directions, please take a few moments to read all of this booklet. It has many helpful tips and ideas on properly setting up and using your system. We promise that if you take the time to read and follow these tips you'll get better system performance and more enjoyment.*

Unpacking the Speakers

Use care when unpacking these speakers as they are large and heavy. Since the grilles are packed off the speakers, be particularly careful of the driver elements as you unpack and move the speakers.

Attaching the Grilles

The included metal grilles are held to the front of the enclosures with powerful Neodymium magnets. There are recesses on the back of the grille that the magnets fit into. Once the speakers are in their final position, remove the grille from its protective plastic bag and carefully position it over the magnets on the baffle. Move them together slowly and when you get close enough, the magnets will draw the grille in and hold it tight. Be careful not to get your fingers caught between the grille and the cabinet.

What's THX?

THX is a series of standards and technologies originally developed by LucasFilm Ltd. (of Star Wars fame) and now an entity unto itself. These technologies and standards are intended to ensure that what you hear and see on your A/V system, as closely as possible, matches what the director/artist/engineer heard and saw during the final mixing of the source material. THX standards are intended to enhance every type of viewing and listening experience including the latest discrete multi-channel digital formats. Please note however that, although there is proprietary THX electronic processing, THX is not a surround format.

THX Ultra2 standards are based on a 3000 cubic foot room (L x W x H = cu. ft.). This does not mean Ultra2 certified components must be used in rooms this exact size. The room sizes simply provide a frame of reference, as the standards specify that the system must deliver certain performance minimums (volume, frequency response, etc.) in the specified space. For more information, see the THX website at www.thx.com.

Individual Component Descriptions

Model 8200e LR and 6200e LR Front Channel Speakers

The Model 8200e LR Front Channel Speakers (Figure 1) are ultra-high performance three-way systems intended for use only with a quality subwoofer, such as the Atlantic Technology Model 642e SB. Each speaker contains two GLH (Graphite Loaded Homopolymer) 8" woofers, two GLH 5½" midrange drivers, and an advanced 1" Ferrofluid™ cooled, damped silk dome tweeter with a powerful neodymium magnet structure. These components are mounted in an acoustically inert ¾" thick internally braced MDF enclosure. The midrange and tweeter drivers are internally isolated within their own airtight sub-enclosure. The LR speakers are magnetically shielded so they may be placed close to a TV set without concern.

The Model 6200e LR Front Channel Speakers (Figure 1) are ultra-high performance two-way systems intended for use only with a quality subwoofer, such as the Atlantic Technology Model 642e SB. Each speaker contains two GLH (Graphite Loaded Homopolymer) 6.5" woofers and the same advanced 1" Ferrofluid™ tweeter as the 8200e. These components are mounted in an acoustically inert .75" thick internally braced MDF enclosure. The 6200e LR speakers are magnetically shielded so they may be placed close to a TV set without concern.

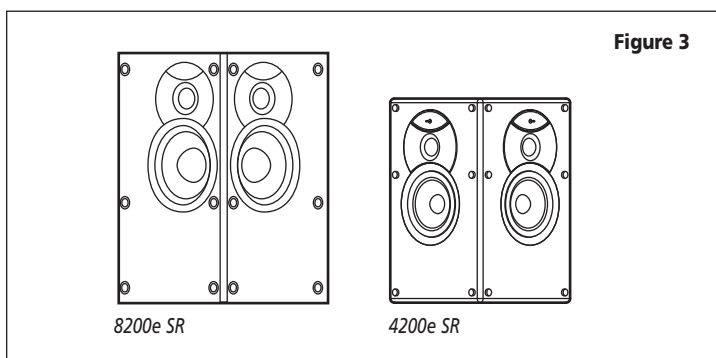
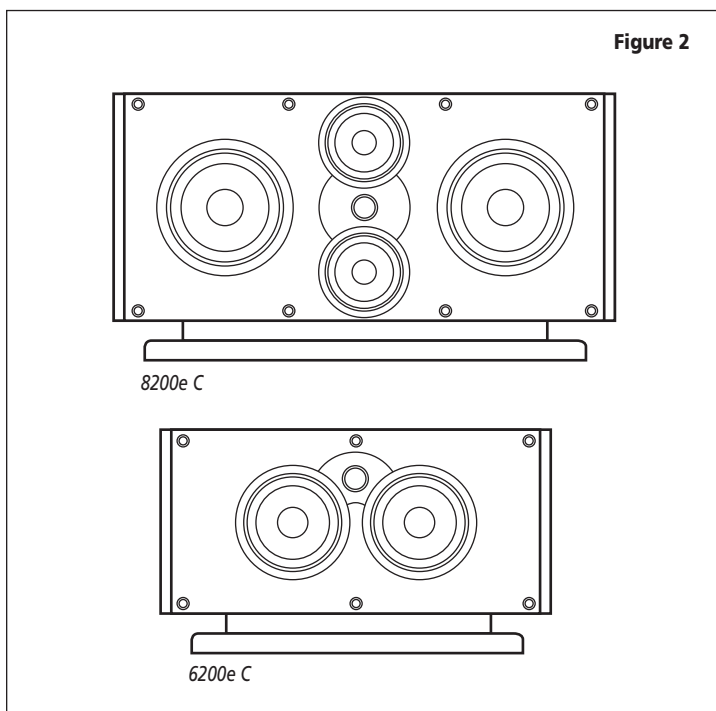
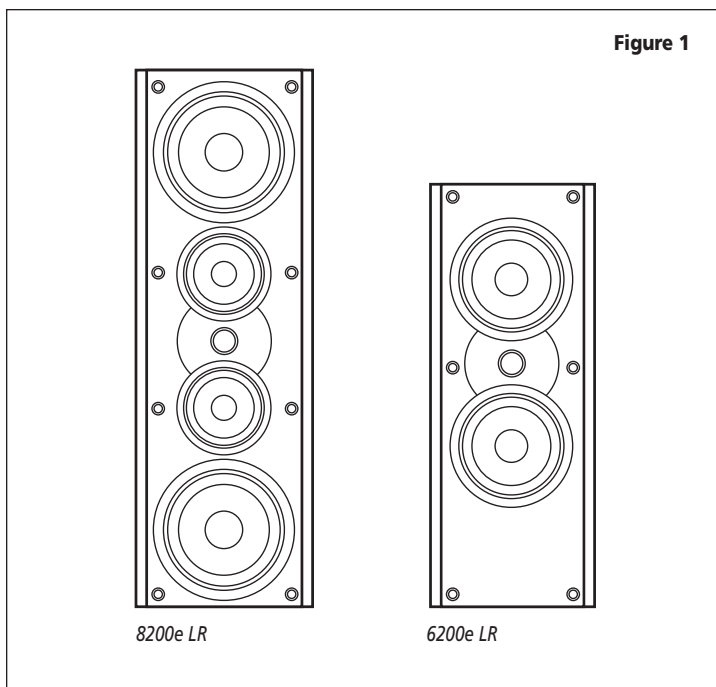

Acoustic Controls

System 8200e and 6200e LR speakers include unique acoustic controls to help maximize their performance in your room. These controls are explained in greater detail on page 9.

Model 8200e C and 6200e C Center Channel Speakers

It is vital to the accurate reproduction of a multi-channel soundtrack that the three front speakers have the same sonic signature. Therefore, the 8200e C and 6200e C Channel Speakers have the same voicing as the LR speakers (see Figure 2). It is designed for use only with a dedicated subwoofer and includes the same unique acoustic controls mentioned above.

The 8200e and 6200e C are designed to be placed horizontally.

Models 8200e SR and 4200e SR Surround Speakers

The Model 8200e SR and 4200e SR Dipole/Bipole Surround Speakers (Figure 3) are intended for use in multi-channel audio/video sound systems only as dedicated side or back surround channel speakers. The 8200e SR utilizes dual 5¼-inch GLH drivers and two of the same tweeters as described above. The 4200e SR utilizes dual 4½-inch GLH drivers and two of the same tweeters as described above. The surround speakers can be switched between Dipole and Bipole operation. These settings are explained on page 10, “Dipole/Bipole Operation of the SR Speakers.”

NOTE: *Although the speakers in the Atlantic Technology Systems 8200e are acoustically and cosmetically matched to each other for ideal results, they may also be used with other Atlantic Technology components with extremely satisfying results.*

Placement

Speaker/room interactions have a huge impact on the sound of the system. Moving the speakers just a little can make a dramatic difference in what you hear. Remember that the best acoustic placement of the speakers will vary from room to room. Use the following placement guidelines (see page 5) as a starting point. But also feel free to experiment. In fact, it may be beneficial to hook up the front LR and surround speakers with some extra wire and to simply drape the wire across the floor before installing the speakers permanently. This will allow you the opportunity to move the speakers around easily so you can find the best sonic and visual locations.

Home Theater

Remember that the primary goal of a good home theater is not to make you believe that you are in a movie theater. It's to make you believe you're in the movie. For a home theater system, place the LR speakers on either side of the television. The left and right front speakers should be far enough apart (6 to 10 feet is usually best) that you get a good stereo “image” when they are playing alone, but not so far apart that the sound seems to be disembodied from the TV, distracting you from the picture. When using a center channel speaker, a wider separation of the left and right front speakers is usually possible. You may choose to “toe” the LR speakers in, aiming them approximately at the prime listening position. This can be particularly useful if the front LR speakers are fairly far apart.

IMPORTANT NOTE *Try to keep the LR and C tweeters approximately centered at or aimed at ear level when seated. This is because the alignment of the drivers on the front panel results in limited vertical spread of the mid and high frequency sounds to reduce unwanted floor and ceiling reflections. If the speakers are too high or too low however, you will miss a significant portion of the upper middle and high range elements of the sound. This alignment of the drivers provides enhanced horizontal spread of the sound making for a much better sound experience for a group of listeners and reducing the need to sit in a precise “sweet spot.”*

The center channel speaker should be placed directly above or below your television. It is important that the speaker is centered on the screen, not off to the side. The pivoting design of the 8200e and 6200e C allows you to tilt it up or down so that the speaker points most directly at the listening position.

Surround Effects and Speaker Locations

The 8200e SR and 4200e SR's shape allows great flexibility in placement. Due to their switchable Dipole/Bipole design, it's possible to place the speakers almost anywhere within the rear third of the room and get good results. However, the best location for surround speakers is straight out to the sides of, or slightly behind the primary listening area, approximately 1-2 feet above seated ear level to no less than 2 feet down from the ceiling.

As noted above, the surround speakers (as opposed to the back speaker(s) in a 5.1, 6.1 or 7.1 channel system, see below) are primarily intended to re-create the ambient sounds taking place in the movie scene. Therefore, throughout most of a movie or TV program you may not be consciously aware of output from these speakers. In other words, don't worry if you aren't hearing the surround speakers. Please try to avoid the trap of turning the surrounds up and up so that you hear them most of the time. The result will be a much less believable surround experience.

There are dedicated LEFT and RIGHT model SR speakers. This is clearly marked on the back of each speaker. Be sure that the Left side surround speaker is placed directly to the left side of the prime listening area (facing the screen) and the Right speaker is directly to the right side. As an easy reference, the Dipole/Bipole switch should always be facing the back of the room. Should you wish to hang them on the wall, closer than 24 inches to the ceiling, you should remove and re-install the keyhole hangers upside down. Then turn the speakers over, hanging them upside down, and swap them side to side for proper operation.

Speaker Placement

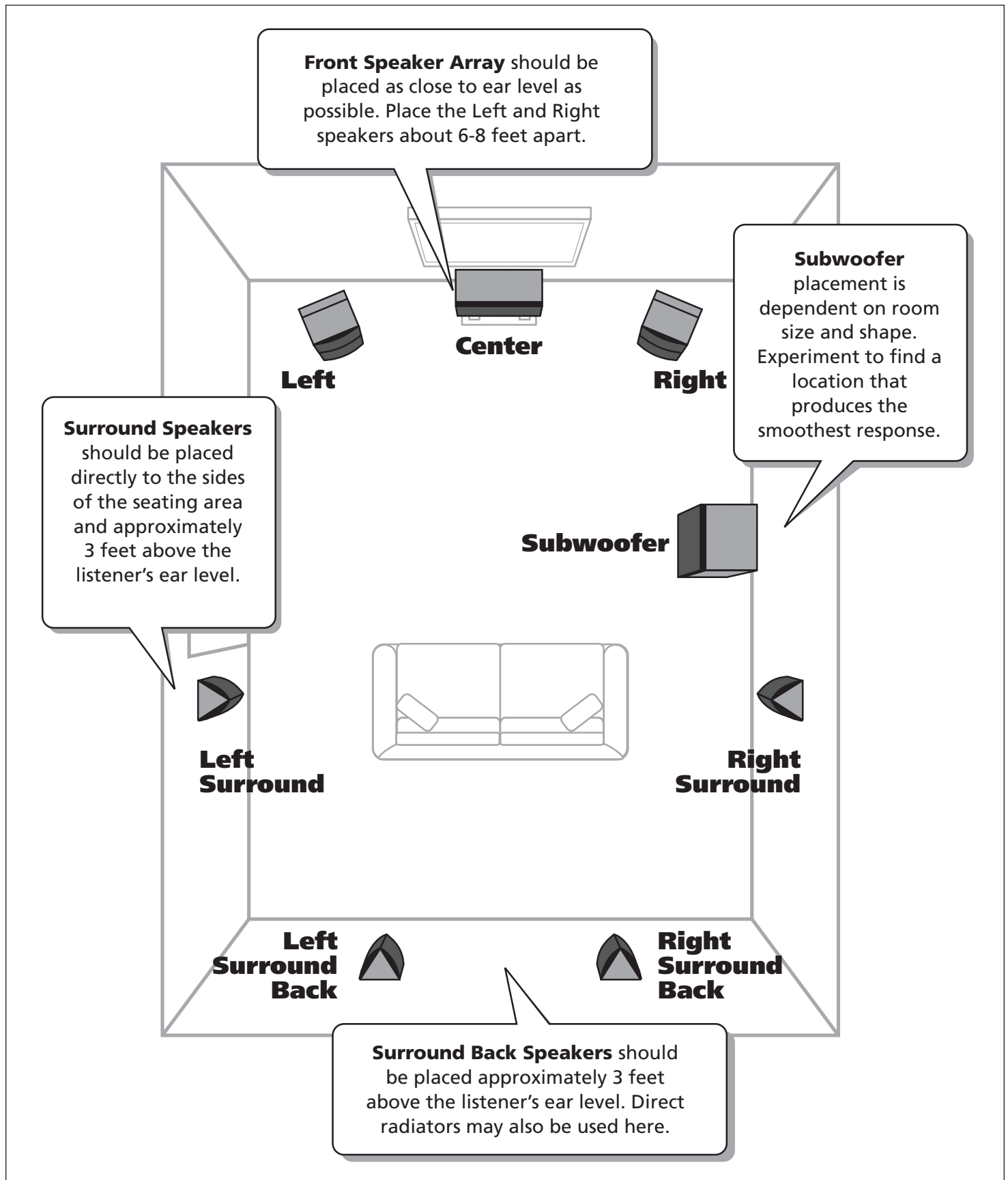

6.1/7.1 Channel Systems

If you are setting up a system that uses back surround speaker(s) as well as side surrounds (Dolby Digital EX, DTS ES, etc.) you can choose to use either SR model speakers in Dipole or Bipole mode or another pair of front LR speakers in the back of the room.

If you are using a THX Ultra 2 certified controller/receiver you should place the back surround speakers approximately 1 to 2 feet apart in the center of the back wall. The special circuitry in the processor will help to create a believable and effective surround field using this placement. Please read the electronics manual to learn more about this placement option.

Stereo Systems

If you are setting up a stereo system using a pair of 8200e or 6200e LRs with subwoofer(s), begin with these general guidelines:

- The distance between the speakers should be approximately one-half their distance from the prime listening position.
- If you point the front of the speakers directly towards the prime listening position (“toe” them in), you will achieve the most precise imaging and the most direct high frequency sound. If you have a “bright” or “hard” sounding room, aiming the speakers straight out into the room (or just aiming them partially towards you) may make for a more natural and pleasing sonic balance.
- The distance from each speaker to its three closest room surfaces should be different.
- In most rooms, you should not place your speakers in the corners.

The goal is to reproduce accurate musical timbre and natural sound. Additionally, a well set-up stereo pair of speakers will create excellent imaging and a cohesive representation of the soundstage. Placement in the room and your listening position have an enormous impact on the ultimate sound you will achieve from your system. The most important thing is to be creative! Try placing your speakers on the long wall instead of the short one. Toe the speakers in or point them straight ahead. Pull them away from the wall or push them closer. Don't be timid. You'll find that moving your speakers, even a few inches, can dramatically change and possibly improve their sound.

Connecting Your System

We recommend that you connect your system using high quality dual conductor stranded wire of 16 gauge or heavier, for lengths up to 25 feet. (Remember, the lower the gauge number, the heavier the wire). Use heavier gauge wire for longer runs. Please contact your audio/video dealer or installer for specific cable recommendations and further information regarding special circumstances.

Bi-Wiring

There are two identical sets of speaker wire connectors on the back of each of the three front enclosures. They are there to provide the option of Bi-Wiring the speakers. Bi-Wiring lets you connect two sets of input wires (or a specially constructed Bi-Wire cable, see your dealer for further details) between the power amplifier or receiver and the speaker. This practice has its roots in high-end audio and it is generally agreed that using two sets of

high quality speaker wires between the speaker and amplifier help to maintain the amplifier's control in the bass range (by maintaining the amplifier's damping factor). It also potentially allows more efficient power transfer by keeping the total resistance of the speaker wires at a lower level.

You can Bi-Wire by connecting two sets of speaker wires from the amplifier terminals to the input terminals on the back of the speaker enclosure. The wires should be attached to a single output terminal set on the amplifier. The other end is attached to the two sets of input terminals on the rear panel of the loudspeaker. Some manufactured Bi-Wire cables have only a single set of connectors at the amplifier end and two sets of connectors at the speaker end.

You may choose to Bi-Wire the speakers or not. If you do Bi-Wire, remove the gold jumper links that comes factory installed between the sets of input terminals (Figure 4). See “System Wiring Using Bi-Wire Option” on the next page for an example of Bi-Wiring.

The terminals themselves are designed to allow the use of very heavy speaker wire or connectors. Be sure to tighten them securely, but don't over-tighten them.

WARNING: To prevent risk of electrical shock or damage to your equipment, always switch off the amplifier or receiver when making any system connections.

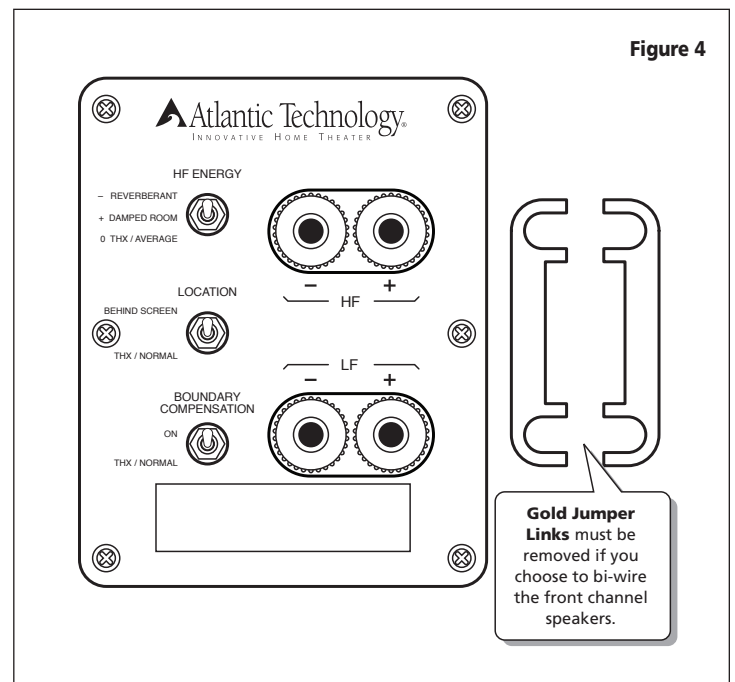
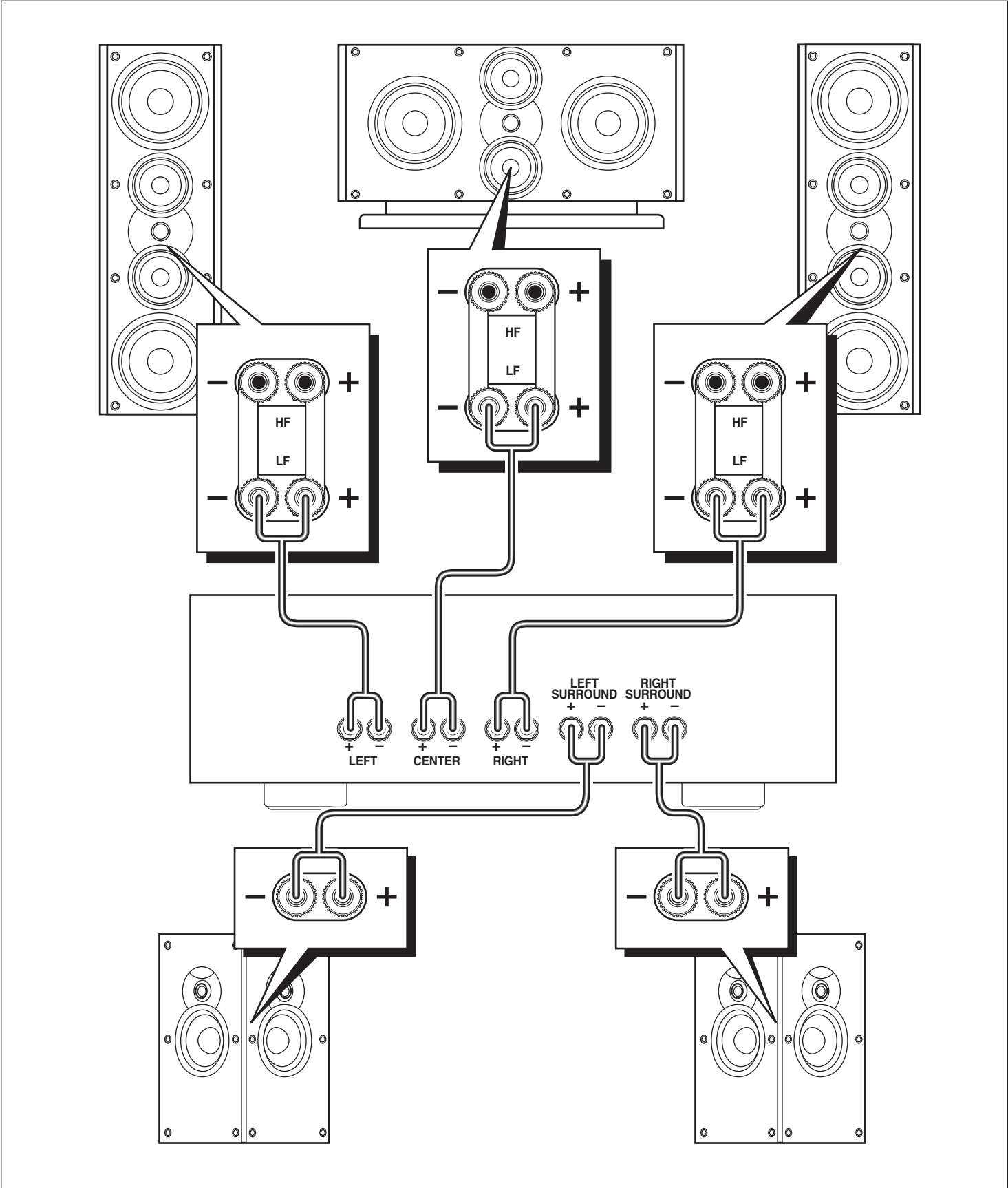

Figure 4

Gold Jumper Links must be removed if you choose to bi-wire the front channel speakers.

System Wiring Without Using Bi-Wire Option



System Wiring Using Bi-Wire Option

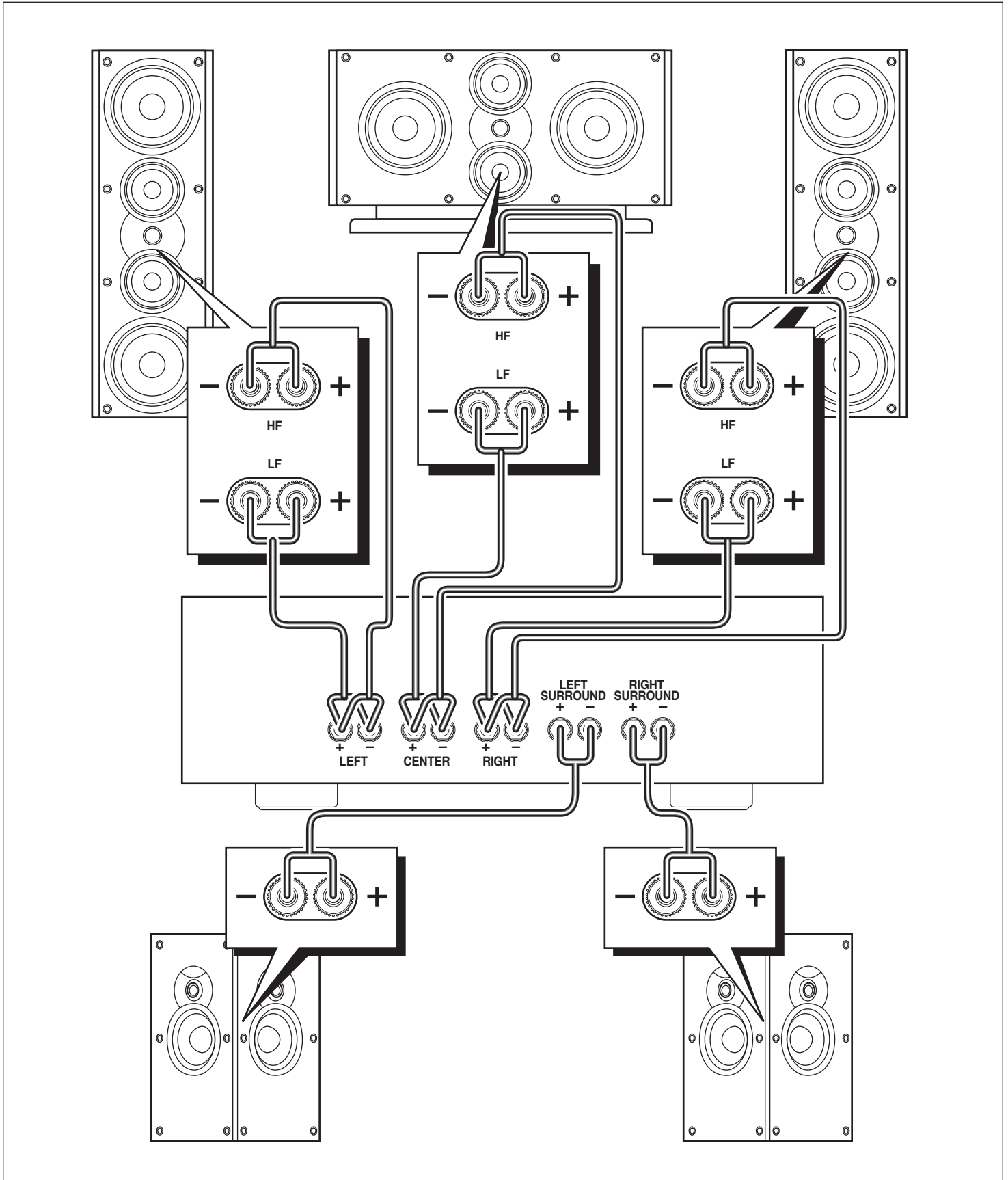

You can connect your speakers by using a variety of audio connectors such as banana plugs (single or double), pin connectors, spade lugs, etc., or you can:

1. Remove ½" of insulation from each wire end.
2. Twist the stranded wire together, keeping the two ends separate.
3. Place the appropriate wire through the appropriate postholes in the connectors. These holes are revealed when you loosen the connector's capscrew.
4. Screw down the capscrew tightly, but be careful not to over tighten it.
5. Check the tightness of the capscrews 24 hours after hookup and occasionally after that, as they can loosen over time.

We recommend that you check your local electrical codes to make sure that you are not using improper connectors.

It's important to observe polarity while making speaker connections: red (+) terminals on the amplifier to red (+) on the speaker, black (-) on the amplifier to black (-) on the speaker. Look carefully at the wires you are using and note that one of the conductors of each pair will typically be identified by color, printing on the outer jacket, ridges on the outer jacket, or a thread intertwined with the wire strands. By convention, the marked wire is connected to the red (+) terminal.

Whether you are connecting a complete system, or adding a single speaker component to your present system, the wiring should look like one of the system wiring diagrams on pages 7 and 8.

WARNING: Before turning on the amplifier, be certain that no stray wire strands are touching across any terminals as this might damage your amplifier.

Finally, check the polarity of your front speakers by listening to some stereo music with good bass content. If the sound seems "hollow", unusually spread out, or seem to have weak mid-bass, recheck your connections for proper polarity and correct any out of phase connections, if necessary.

System Setup

Bass Management

Some older surround sound decoders and receivers offer a choice of "Normal" or "Wide-band" modes for the center channel speaker. The Model 8200e and 6200e C are designed to be used in the Normal mode. Additionally, digital processing multi-channel systems provide a Bass Management menu, which typically requires you to select between "Small" or "Large" speakers during system set-up. Since these systems have been designed to work with a dedicated subwoofer, please set all the speakers in Systems 6200e and 8200e to Small.

Operation of the Rear Panel Controls on the LCR Speakers

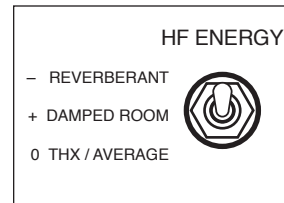

High Frequency Energy This control changes the tilt or roll-off slope of the tweeter. It has been designed to help compensate for different room acoustics. The THX/ Average position is intended for rooms with a reasonable combination of reflective (hard) and absorptive (soft) surfaces. The Reverberant position is designed for rooms with an abundance of reflective surfaces like hardwood or tile floors, glass walls, etc. It decreases the high frequency output of the speaker to reduce excess HF energy that builds up in live rooms. The Damped position brings the tweeter's output slightly above flat response to compensate for overly absorbent rooms with lots of soft surfaces. Speakers in overly damped rooms can sound dead and lifeless unless compensated.

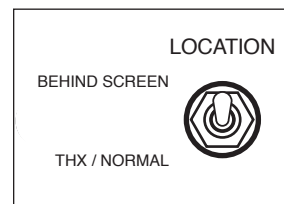

Location This control "shelves up" the upper midrange and high frequency energy from the speaker in the position marked Behind Screen. This is to compensate for the reduction of these frequencies when they are partially blocked by the materials in front of them if the speakers are located

behind a perforated video screen or curtains. Of course, if you choose to place the speakers behind curtains it is important to choose a material that is as acoustically transparent as possible. Looking through the material into the light can give you some indication of the material's transparency in this regard. The more light and detail you can see, the better it will be acoustically.

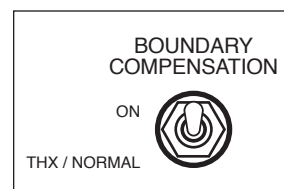

Boundary Compensation Use this switch to adjust the lower midrange output of the speaker to compensate for the typical sound colorations caused by placing the speaker close to a TV screen or building it into a wall unit or cabinet.

To set these controls, sit in the prime listening position and have someone switch between the compensation choices, using well recorded dialogue or musical instrument recordings. Choose whichever switch position sounds most natural and real to you.

NOTE: Although these controls have been designed to compensate for various acoustic room anomalies, we recommend that you try them to hear the difference that they make in the sound of the system. For any number of reasons, you may decide that you prefer them set in a particular manner inconsistent with your room's acoustics, but sounds best to you. Experiment. It will be worth it.

Dipole/Bipole Operation of the SR Speakers

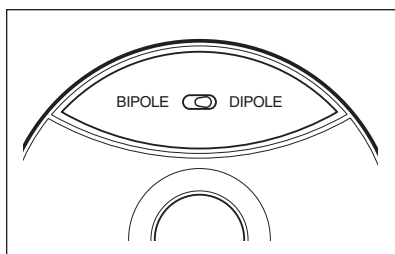

In Dipole mode the 8200e SR and 4200e SR produces ambience with minimal localization (best for most movies and video soundtracks) and more localizable sound in the Bipole mode (preferred for some music recordings). Switching

between Dipole and Bipole mode is easily accomplished using a toggle switch conveniently located under one of the speaker's grilles.

Please note that the vast majority of the time in movies and TV broadcasts the surround speakers are called upon to reproduce the environmental sounds that are used as cues to help get you immersed in the scene on the screen. We strongly recommend that (if the speakers are properly positioned directly to the sides or rear of the listening area) you set them to Dipole mode, as this is undoubtedly the best and most practical way to create such an involving and believable soundfield at home.

Setting Levels

When setting up a complete home theater we strongly recommend that you use a Sound Pressure Level (SPL) meter. As of this writing Radio Shack® has one that's affordably priced (approximately \$60) that can be used effectively. To use this meter, turn on your system, put the processor/receiver in Test Mode and set its main volume control to 0dB (or a reasonably loud level). Sit in the prime listening position, set the SPL meter to the 70dB scale, slow response, and C weighting. Hold the meter with the microphone pointed up, towards the ceiling and in front of you. Cycle the test tone from speaker to speaker, setting each to the same level (usually 75dB) using the individual level settings available in the processor/receiver (please see the instructions for your processor/receiver if you are unsure of how to access the test signal or level controls).

IMPORTANT NOTE: *The power recommendation for these speaker components assumes that you will not operate your amplifier/receiver in a way that produces distortion. Even rugged speakers like these can be damaged by an amplifier driven beyond its capability. The harsh amplifier distortion ("clipping") that occurs in this situation will eventually cause damage to the speaker system. This type of damage may be cumulative and can build up over time, as the amplifier is driven into overload again and again. Such damage is easily identifiable through examination of the damaged speaker's voice coil and is not covered by the warranty.*

These systems will play very loudly when provided with enough undistorted power to do so. If necessary, consult your dealer or Atlantic Technology for additional information.

Mounting

System 8200e/6200e speakers can be mounted in different ways:

On Pedestals Optionally available Atlantic Technology empty pedestals are an attractive alternative in most rooms. They come in gloss black to match the LR's or satin black to match the SR's (8200e SR only).

On the Wall (8200e SR and 4200e SR only) To mount your speakers on a wall, we have supplied metal key-hole brackets attached to the back of the cabinet.

These speakers are heavy and care must be used when hanging them. Be sure to use a strong screw to drive into the wall, one whose head and shaft will fit within properly the keyhole opening and slot. Also be sure to drive the screw directly into a stud or to use a mounting device (such as a molly-bolt) that is capable of safely holding the speaker's weight. Never simply drive a nail or screw into sheet rock or other wall materials. Always follow the above guidelines for safe speaker mounting.

Caring for Your Speakers

Clean your cabinets using a soft lint-free cloth. If you wish, you can slightly moisten the cloth with plain water. Do not use any other cleaning agents or chemicals. Be careful not to get any water on the driver cones or tweeter domes. After carefully removing the grilles from the speakers by pulling them forward, gently clean them with a quick pass from a vacuum cleaner with a brush attachment. This should remove any dust accumulation. Re-attach them by lining up the magnet depressions in the back of the grilles with the magnets on the speaker baffle and slowly moving them closer until they connect with each other.

Avoid placing your speakers in direct sunlight or near a source of heat that may, over time, damage the finish.

IMPORTANT: SAVE YOUR BOXES! *If you can do so, save the cartons, packing pieces, and plastic bags that came with your speakers. They will be useful in case you move or have to ship your loudspeakers for any reason. In any case, save all packing materials until you are certain that the systems have suffered no damage in shipment. If you find such damage, either visible or internal, contact your dealer immediately for the proper return procedure.*

Specifications

System 8200e

Model	8200e LR	8200e C	8200e SR
Type	Sealed-box, 3-way M-T-M Array	Sealed-box, 3-way M-T-M Array	Sealed-box, Dipole/Bipole surround speaker
Drivers	Woofer (2) 8" GLH Midrange (2) 5¼" GLH Tweeter (1) 1" silk dome	(2) 8" GLH (2) 5¼" GLH (1) 1" silk dome	(2) 5¼" GLH (2) 1" silk dome
Frequency Response	60Hz – 20kHz ±2dB	60Hz – 20kHz ±2dB	80Hz – 20kHz ±2dB
Nominal Impedance	6Ω	6Ω	6Ω
Crossover Frequency	450Hz, 3kHz	450Hz, 3kHz	3kHz
Crossover Type	Computer designed Butterworth 4th order asymmetrical (time-aligned) Linkwitz-Riley		
Sensitivity	90dB	90dB	90dB
Recommended Amplifier Power	25 – 200 Watts RMS	25 – 200 Watts RMS	10 – 150 Watts RMS
Dimensions w/ grilles (W x H x D)	10.6 x 31.1 x 11.9in 270 x 790 x 302mm	28.5 x 16 x 11in* 724 x 406 x 330mm*	10.8 x 15.3 x 7.8in 269 x 380 x 193mm
Pedestals including feet, spikes, and gap between satellite and pedestal top adds to height: 22.4in., 569mm			
Weight (ea)	53.0lbs; 24.0kg	55.0lbs; 25.0kg w/base	20.0lbs; 9.1kg

*Height includes tilt base.

Specifications are those in effect at the time of printing. Atlantic Technology reserves the right to change specifications or appearance at any time without notice.

THX and THX Ultra 2 are trademarks of THX Inc. Dolby Digital, 5.1, Dolby Digital, 7.1, Dolby Stereo and Dolby Pro Logic are trademarks of Dolby Laboratories Licensing Corporation. DTS is a registered trademark of DTS Technology.

System 6200e

Model	6200e LR	6200e C	4200e SR
Type	Sealed-box, 2-way M-T-M Array	Sealed-box, 2-way M-T-M Array	Sealed-box, Dipole/Bipole surround speaker
Drivers	Woofer (2) 6½" GLH Tweeter (1) 1" silk dome	(2) 6½" GLH (1) 1" silk dome	(2) 4½" GLH (2) 1" silk dome
Frequency Response	60Hz – 20kHz ±2dB	60Hz – 20kHz ±2dB	80Hz – 20kHz ±2dB
Nominal Impedance	6Ω	6Ω	8Ω
Crossover Frequency	2.5kHz	2.5kHz	3kHz
Crossover Type	Computer designed Butterworth 4th order asymmetrical (time-aligned) Linkwitz-Riley		
Sensitivity	90dB	90dB	90dB
Recommended Amplifier Power	15 – 150 Watts RMS	15 – 150 Watts RMS	10 – 150 Watts RMS
Dimensions w/ grilles (W x H x D)	9.1 x 23.1 x 11.5in 232 x 587 x 292mm	21.5 x 11.1 x 12in* 546 x 281 x 305mm*	10.9 x 12.4 x 7.5in 277 x 315 x 191mm
Pedestals including feet, spikes, and gap between satellite and pedestal top adds to height: 23.9in., 608mm			
Weight (ea)	26lbs; 11.8kg	25.0lbs; 11.3kg w/base	11lbs; 4.99kg



343 Vanderbilt Avenue Norwood, MA 02062 (781) 762-6300 www.atlantictechnology.com

015-1811-D

