

Because you're not like everyone else.

luma ● ● ● TM
comfort



**MISTING FAN
MF24B
OWNER'S MANUAL**

Manual v1.0

BECAUSE YOU'RE NOT LIKE EVERYONE ELSE

And neither are we. Always at the forefront of our industry, our goal is to offer the best quality product and consumer value on the market. Our team is constantly pushing the boundaries of innovation and design to create exceptional products to help you achieve a more comfortable living or work space.

Our goal is to ensure that every Luma Comfort customer is 100% satisfied with their product. If you have any questions or concerns regarding your product, or if you would simply like to share an idea with us, please feel free to contact us.

Contact Us:

For questions regarding your product, please contact us at:

Call: 1-855-963-9247
Email: support@lumacomfort.com
Online: www.lumacomfort.com

Connect with Us:

 [Facebook.com/lumacomfort](https://www.facebook.com/lumacomfort)

 [Instagram.com/luma_comfort](https://www.instagram.com/luma_comfort)

 [YouTube.com/lumacomfort](https://www.youtube.com/lumacomfort)

 [Twitter.com/lumacomfort](https://www.twitter.com/lumacomfort)

● ● ● CONTENTS

Because You're Not Like Everyone Else	2
Register Your Product Online	4
Important Safety Information	5
Get To Know Your Misting Fan	6
Product Benefits	6
Parts List.....	6
Assembly Instructions.....	7
Step 1: Assembling the Stand Pole.....	7
Step 2: Connecting the Back Panel	8
Step 3: Connecting the Water Line.....	9
Step 4: Connecting the Fan Head to the Stand Pole	9
Step 5: Assembling the Water Tank	11
Operating Instructions.....	12
Maintenance	13
Technical Support.....	14
Product Specifications	14
Troubleshooting	14
Warranty	15

SAVE THESE INSTRUCTIONS

Please carefully read this manual before attempting to use this misting fan. For your own safety, comply with all safety instructions and warnings contained in this owner's manual to prevent personal injury or property damage.

REGISTER YOUR PRODUCT ONLINE

Register Your Luma Comfort Product Online Today!

Take advantage of all the benefits product registration has to offer:



Service and Support

Diagnose troubleshooting and service issues faster and more accurately



Recall Notifications

Stay up to date for safety, system updates and recall notifications



Special Promotions

Opt-in for NewAir promotions and offers

Registering your product information online is safe & secure and takes less than 2 minutes to complete:

[Register.LumaComfort.com](https://www.Register.LumaComfort.com)

Alternatively, we recommend you attach a copy of your sales receipt below and record the following information, located on the manufacturer's nameplate on the rear of the unit. You will need this information if it becomes necessary to contact the manufacturer for service inquiries.

Date of Purchase: _____

Serial Number: _____



Model Number: _____



IMPORTANT SAFETY INFORMATION



These instructions are not meant to cover every possible condition and situation that may occur. Please read all instructions before using this misting fan. Failure to carefully read all instructions may result in possible electric shock or fire hazard, and will void the manufacturer's warranty.

1. Use this misting fan only as instructed in this owner's manual. Other uses may cause electric shock, injury or fire.
2. Close supervision is required if this fan is used near children or pets.
3. To protect against electric shock, do not immerse this fan or its plug and cord in water.
4. If the fan is being transported or will not be in use, disconnect it from the power supply by tightly gripping the fan's plug and pulling it from the power outlet. Do not disconnect the power supply by pulling on the fan's power cord.
5. Avoid contact with any of the misting fan's moving parts.
6. Place the misting fan on a level surface.
7. This misting fan is intended to fit into a matching receptacle. Under no circumstances should the grounded plug be altered in any way. An improper connection can result in electric shock. 
8. If possible, avoid using extension cords with this misting fan. If an extension cord is absolutely necessary, do not use more than one extension cord and do not use a single extension cord to operate more than one fan.
9. Do not insert objects or allow fingers to enter into the fan head, as this may cause electric shock or bodily injury. Do not block or tamper with the misting fan while it is in operation.
10. Do not place the fan near curtains, drapes, or any other materials that can get caught in the misting fan's grills.
11. Do not run the power cord under mats or carpeting, and do not cover the power cord with runners. Arrange the power cord away from room traffic or where it can be tripped over.
12. Do not operate this misting fan in the presence of flammable substances or explosives.
13. Do not place the fan near an open flame or cooking/heating appliances.
14. If the fan will not be in use, empty the tank of any remaining water.
15. If the fan's plug or power cord is damaged, do not attempt to repair the components yourself. Please contact Luma Comfort's customer service hotline at 1-866-737-6390 or have the fan examined by an authorized service provider. 

● ● ● GET TO KNOW YOUR MISTING FAN

PRODUCT BENEFITS

- Designed for cooling large areas such as patios, factories, manufacturing facilities, garages, athletic fields, greenhouses and more
- Centrifugal misting system means there's no clogged nozzles and no need to use filtered water
- Constructed of heavy-gauge, anticorrosive metal for safety and durability
- Quiet, high-efficiency fan motor
- Adjustable misting flow with a fully-insulated seal around the water pump
- Oscillating fan head covers a wider area
- Adds moisture to dry environments and eliminates airborne dust particles
- Covers up to 800 square feet and features a 4-hour maximum run time with each full tank

PARTS LIST

Check to insure the following parts are included with your product:

- 4 M6x16 screws
- large washers
- small washers
- nuts
- Stand pole
- fan base
- water pump
- metal pipe
- fan head
- water tank

● ● ● ASSEMBLY INSTRUCTIONS

 It is strongly recommended that a second person be available to assist during the assembly process.

DO NOT plug in the fan before assembly. This misting fan comes in two separate boxes. Carefully remove all packaging materials and retain for future storage/use. Make sure there is no residual foam left in any of the components. A screwdriver and wrench will be required to assemble this misting fan.

STEP 1: ASSEMBLING THE STAND POLE

1. Refer to *diagram 1* below. Remove the following parts from the fan's base and set them aside: four (4) M6x16 screws, large washers, small washers, and nuts.
2. Place the stand pole on the fan base, align the screw holes and secure the pole in place using the screws, washers and nuts. Make sure the hole located near the bottom of the stand pole is facing the square shaped pump slot.

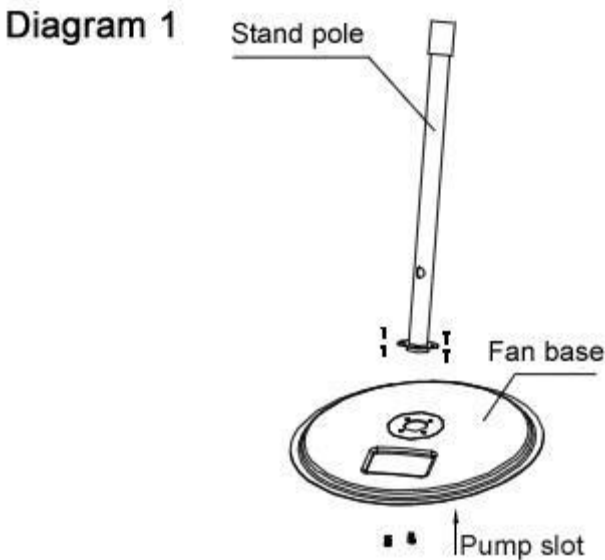

STEP 2: CONNECTING THE BACK PANEL

1. *Refer to diagram 2.* Find the rectangular panel located on the back of the stand pole. Remove this back panel from the stand pole by completely unscrewing it from the stand pole. Set it aside.
2. Locate the water pump. This is packaged separately from the stand pole and can be found in box #1. You will see 2 water hoses (1 large and 1 small) and 1 electric wire connected to the water pump. Thread the hoses and wire into hole A (smaller, circular hole) and up the stand pole through hole B (larger, elliptical shaped hole).
3. Locate the back panel removed in step 1 and orient it so that the label with the fan speeds is located on top of the dial.
4. Take the small water hose from hole B and locate the connector that is attached to the back panel. Connect the small water hose to the lower valve opening on the connector.

Diagram 2

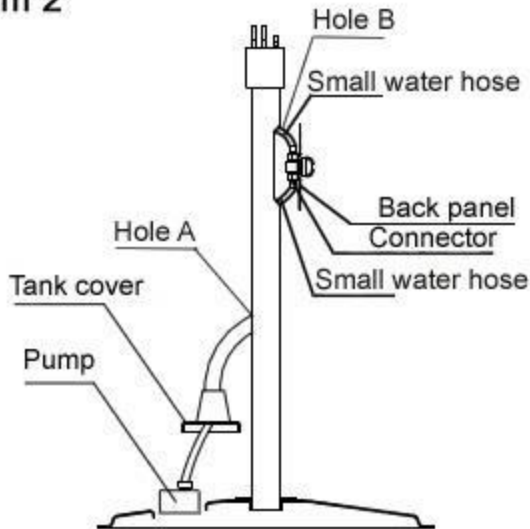

STEP 3: CONNECTING THE WATER LINE

1. Refer to *diagram 3*. Locate the metal pipe and fan head and attach the fan head onto the pipe. The fan head should have 2 water hoses (1 large and 1 small) and 1 electric wire with male connector plug connected to it.
2. Take the electric wire with the male connector that is located on the back of the fan head and thread it through hole D.
3. Take the large water hose with 2 smaller water hoses within it and thread the entire piece through hole C. You should now have the water hoses and electric wire coming out the end of the metal pipe.

Diagram 3

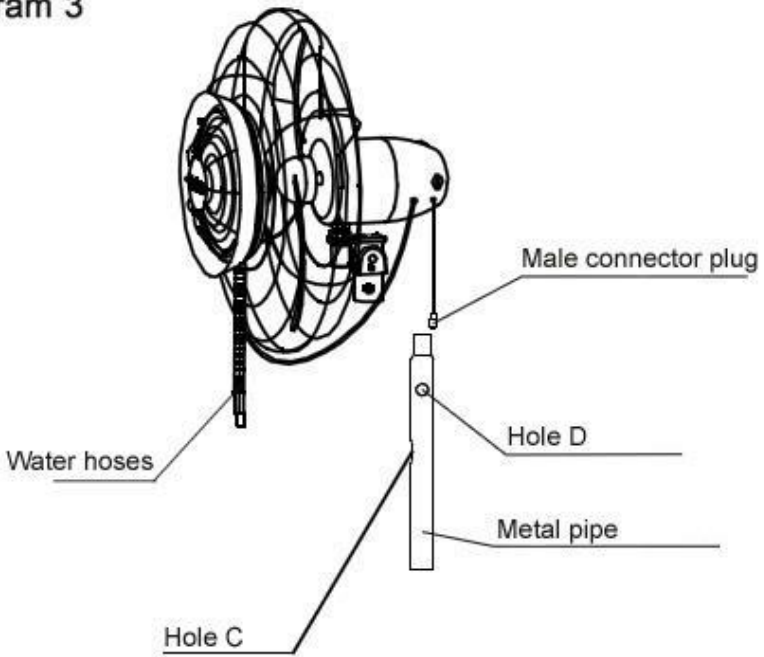

STEP 4: CONNECTING THE FAN HEAD TO THE STAND POLE

1. *Refer to diagram 4.* Place the stand pole/base on a level surface.
2. Take the water hoses and electric wire from the fan head/pipe and thread them through the top of the stand pole. Do not attach the fan head to the stand pole yet.
3. Connect the male and female connector plugs together.
4. Take the small water hose from the fan head/metal pipe and connect it to the other valve opening attached to the back panel.
5. Locate the large water hose from the fan head/metal pipe and connect it to the large connector with the quick release valve.
6. Attach the fan head/metal pipe onto the stand pole and thread all hoses and wires into the stand pole through hole B (elliptical shaped hole on the stand pole). Make sure none of the hoses or wires are bent.
7. Reattach the screws onto the back panel.
8. Tighten the bolts located on the sleeve by the back panel to secure the stand pole and fan head/pipe together.

Diagram 4

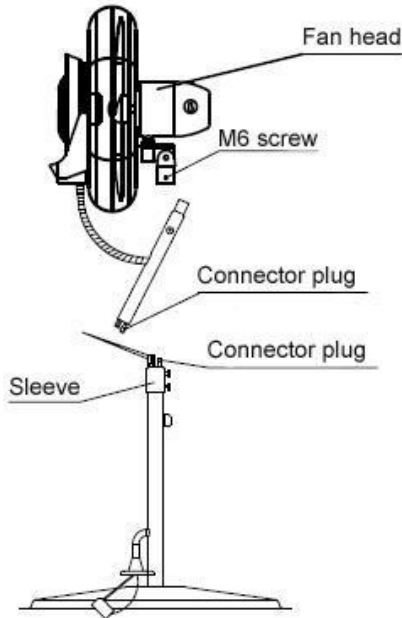

STEP 5: ASSEMBLING THE WATER TANK

1. Refer to diagram 5. Take the water pump and place it in the pump slot.
2. Locate the water tank and place it on the fan base, making sure to line up the pump opening with the pump slot so that they fit together. Place any protruding hoses or wires into the tank.
3. Put the tank cover over the tank.

Diagram 5

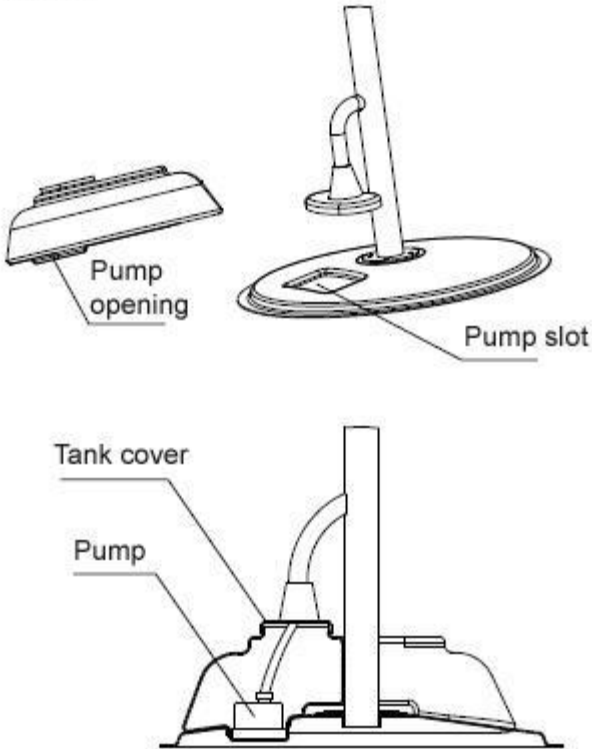

● ● ● OPERATING INSTRUCTIONS

1. This misting fan can operate with optimal output in temperatures up to 104°F.
2. Lift up the tank cover and fill the tank with clean water.
3. Connect the fan to a power supply.
4. Turn on the fan by pressing the red power switch.
5. This misting fan has 3 different fan speeds. Turn the speed dial to adjust the fan speed.
6. To start the misting function, press the misting button located on the stand pole. The misting function will only work if the fan speed is set. The pump and misting plate should power on at this time.
7. To adjust the misting volume, turn the misting switch dial located near the top of the fan head.
8. To turn on the oscillation function, turn the oscillation dial located on the back of the fan motor.
9. The maximum run time for a full tank on high speed is approximately 4 hours.

Diagram 6

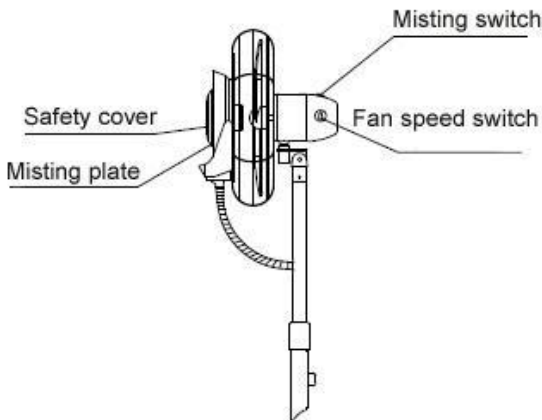

Keep in mind that the effectiveness of this misting fan improves as the temperature rises, but in areas with high humidity levels, you may want to use the fan with the misting function turned off for the best results.

● ● ● MAINTENANCE

Always unplug the misting fan from the power supply before servicing or cleaning.

Regular cleaning and maintenance is an essential step in maintaining the longevity of your misting fan and ensuring that it operates free of defects. Maintain your misting fan by following these steps:

- Use a soft cloth and a solution of mild soap and warm water to clean the fan's exterior. Do not use harsh cleaners, gasoline, paint thinner, benzene, etc., as these substances can damage the misting fan.
- Thoroughly dry all of the fan's parts with a soft cloth before reconnecting the unit to a power supply.
- Drain the water tank after the misting fan has been in use. Regular, scheduled cleaning of the water tank and misting plate before each use is also recommended.
- To clean the water tank, open the tank cover, remove the pump and then remove the tank from the base. Always remember to remove the pump before cleaning the water tank.
- If the misting fan will not be in use for an extended period of time, empty the water tank, cover the unit and keep it stored in a clean, dry place.

● ● ● TECHNICAL SUPPORT

Luma Comfort is committed to providing a premier service experience. If you are experiencing any technical issues with your product related to either setup or operation, please contact our product support team at 1-866-737-6390 or support@lumacomfort.com.

PRODUCT SPECIFICATIONS

Model:	MF24B
Product Dimensions:	17" (D) x 24" (W) x 65" (H)
Product Weight:	50 pounds
Voltage:	110V – 120V
Wattage:	280W
Fan Head Size:	24"
Coverage Area:	Up to 800 sq. ft.
Maximum Run Time:	4 hours on high speed
Tank Size:	1.76 gallons
Fan Speeds:	3
RPMs	1200/1300/1500
Noise Levels (dB)	62/67/70
Temperature Drop:	30-45°F
Oscillation:	90°
Warranty:	1 year manufacturer's warranty

TROUBLESHOOTING

Problem	Possible Cause(s)	Possible Solution
The fan does not turn on.	The power cord is not plugged in.	Check to make sure the plug is plugged into an outlet.
No mist is coming out of the unit.	The water tank is empty.	Make sure there is water in the tank.
Water is leaking out of the water hose.	The connections are not tightly secured.	Check to make sure all of the fan's components are securely connected together.
The fan produces uneven mist.	There is a leak in the water hose.	Turn off the misting function and see if there are any air leaks in the hose. If the problem persists, contact customer service.

● ● ● WARRANTY

Luma Comfort products are warranted to be free from defects in workmanship or materials for one (1) year from the date of purchase. If the product is found to be defective within this period, Luma Comfort, at its sole option, will repair or replace any components that fail during normal operation. The repairs or replacement will be made at no charge to the customer for parts and labor, assuming that the customer shall be responsible for all transportation costs to and from Luma Comfort. Luma Comfort retains the right to repair or replace (with a new or newly-refurbished replacement product) the appliance at its sole discretion. This warranty does NOT apply to the following:

- Products without a proof of purchase
- Products purchased from a source other than an authorized Luma Comfort dealer
- Cosmetic damage such as scratches or dents
- Damage caused by service performed by anyone who is not an authorized service provider of Luma Comfort
- Damage in transit
- Damage caused by accident, abuse, misuse, water, flood, fire, improper installation, maintenance negligence, commercial use for a non-commercial unit, acts of God or any other acts of nature or external causes
- Damage to a product caused by modifications or alterations without the written permission of Luma Comfort
- Normal wear and tear of parts that are designed to be replaced, such as filters or batteries
- Power failure and improper power supply such as low voltage, defective wiring or inadequate fuses
- Use of force or damage caused by external influences
- Complete or partially dismantled appliances

THE WARRANTIES AND REMEDIES CONTAINED HEREIN ARE EXCLUSIVE AND IN LIEU OF ALL OTHER WARRANTIES EXPRESS, IMPLIED, OR STATUTORY, INCLUDING ANY LIABILITY ARISING UNDER ANY WARRANTY OF MERCHANTABILITY OR FITNESS FOR A PARTICULAR PURPOSE, STATUTORY OR OTHERWISE. THIS WARRANTY GIVES YOU SPECIFIC LEGAL RIGHTS, WHICH MAY VARY FROM STATE TO STATE.

IN NO EVENT SHALL LUMA COMFORT BE LIABLE FOR ANY INCIDENTAL, SPECIAL, INDIRECT, OR CONSEQUENTIAL DAMAGES, WHETHER RESULTING FROM THE USE, MISUSE, OR INABILITY TO USE THIS PRODUCT OR FROM DEFECTS IN THE PRODUCT. SOME STATES DO NOT ALLOW THE EXCLUSION OF INCIDENTAL OR CONSEQUENTIAL DAMAGES, SO THE ABOVE LIMITATIONS MAY NOT APPLY TO YOU.

If you believe your product is defective, contact Luma Comfort for warranty service at 1-866-737-6390 or support@lumacomfort.com. In your correspondence with Luma Comfort, please describe the problem and request a return material authorization (RMA) number. You will also need to provide the proof of purchase, return shipping address and a daytime phone number.

After a Luma Comfort representative confirms that your product is defective and is still under warranty, you will receive an RMA and return shipping instructions. Products sent to our headquarters without an RMA will be refused.