

THANK YOU for purchasing this high-quality product. Register your freezer at www.amana.com. In Canada, register your freezer at www.amanacanada.ca.

For future reference, please make a note of your product model and serial numbers. These numbers can be found inside your freezer.

Model Number

Serial Number

TABLE OF CONTENTS

SAFETY	1	CARING FOR YOUR FREEZER	8
INSTALLING YOUR FREEZER	2	Cleaning Your Frost-Free Freezer	8
Unpacking.....	2	Defrosting and Cleaning Your Manual Defrost Freezer.....	9
Location Requirements.....	3	Changing the Light Bulb	9
Electrical Requirements.....	3	Power Interruptions	10
Freezer Door.....	4	Moving Care	10
Freezer Leveling and Door Closing.....	5	PROBLEM SOLVER	10
OPERATING YOUR FREEZER	6	Freezer Operation	11
Ensuring Proper Air Circulation	6	WARRANTY	12
Using the Control	6		
Freezer Features	7		

SAFETY

Your safety and the safety of others are very important.

We have provided many important safety messages in this manual and on your appliance. Always read and obey all safety messages.



This is the safety alert symbol.

This symbol alerts you to potential hazards that can kill or hurt you and others.

All safety messages will follow the safety alert symbol and either the word “DANGER” or “WARNING.”

These words mean:

⚠ DANGER

You can be killed or seriously injured if you don't immediately follow instructions.

⚠ WARNING

You can be killed or seriously injured if you don't follow instructions.

All safety messages will tell you what the potential hazard is, tell you how to reduce the chance of injury, and tell you what can happen if the instructions are not followed.

IMPORTANT SAFETY INSTRUCTIONS

WARNING: To reduce the risk of fire, electric shock, or injury when using your freezer, follow these basic precautions:

- Plug into a grounded 3 prong outlet.
- Do not remove ground prong.
- Do not use an adapter.
- Do not use an extension cord.
- Disconnect power before servicing.
- Replace all parts and panels before operating.
- Use nonflammable cleaner.
- Keep flammable materials and vapors, such as gasoline, away from freezer.
- Use two or more people to move and install freezer.
- Keep key away from children.
- Remove doors or lid from your old freezer or refrigerator.
- Disconnect power before installing ice maker (on ice maker kit ready models only).

SAVE THESE INSTRUCTIONS

State of California Proposition 65 Warnings:

WARNING: This product contains one or more chemicals known to the State of California to cause cancer.

WARNING: This product contains one or more chemicals known to the State of California to cause birth defects or other reproductive harm.

PROPER DISPOSAL OF YOUR OLD FREEZER OR REFRIGERATOR

⚠ WARNING

Suffocation Hazard

Remove doors or lid from your old freezer or refrigerator.

Failure to do so can result in death or brain damage.

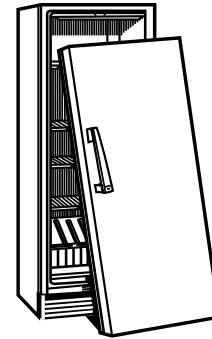

IMPORTANT: Child entrapment and suffocation are not problems of the past. Junked or abandoned freezers or refrigerators are still dangerous... even if they will sit for "just a few days." If you are getting rid of your old refrigerator or freezer, please follow these instructions to help prevent accidents.

Before You Throw Away Your Old Freezer or Refrigerator:

- Take off the doors or lid.
- Leave the shelves in place so that children may not easily climb inside.

Important information to know about disposal of refrigerants:

Dispose of freezer in accordance with Federal and Local regulations. Refrigerants must be evacuated by a licensed, EPA certified refrigerant technician in accordance with established procedures.

INSTALLING YOUR FREEZER

Unpacking

⚠ WARNING

Excessive Weight Hazard

Use two or more people to move and install freezer.

Failure to do so can result in back or other injury.

Remove Packaging Materials

- Remove tape and glue residue from surfaces before turning on the freezer. Rub a small amount of liquid dish soap over the adhesive with your fingers. Wipe with warm water and dry.

- Do not use sharp instruments, rubbing alcohol, flammable fluids, or abrasive cleaners to remove tape or glue. These products can damage the surface of your freezer. For more information, see "Safety."

When Moving Your Freezer:

Your freezer is heavy. When moving the freezer for cleaning or service, be sure to cover the floor with cardboard or hardboard to avoid floor damage. Always pull the freezer straight out when moving it. Do not wiggle or "walk" the freezer when trying to move it, as floor damage could occur.

Clean Before Using

After you remove all of the packaging materials, clean the inside of your freezer before using it. See the cleaning instructions in “Caring for Your Freezer.”

Location Requirements

⚠ WARNING



Explosion Hazard

Keep flammable materials and vapors, such as gasoline, away from freezer.

Failure to do so can result in death, explosion, or fire.

Ventilation and Clearance

- Keep flammable materials and vapors, such as gasoline, away from freezer.
- Do not cover the freezer with items such as blankets, sheets, tablecloths, etc. This reduces air circulation.
- Allow at least 3" (7.5 cm) of air space at the top and on both sides of the freezer and 1" (2.5 cm) between the back of the freezer and the wall. If the freezer is to be against a wall, leave extra space on the hinge side so the door can open wider.

Temperature

Your freezer operates most efficiently when located in an area where the temperature will not fall below 40°F (5°C). Place your freezer in a location where the temperature will not fall below this recommended temperature.

Upon Moving to Final Location

NOTE: Allow at least 3" (7.5 cm) of air space at the top and on both sides of the freezer and 1" (2.5 cm) between the back of the freezer and the wall. If the freezer is to be against a wall, leave extra space on the hinge side so the door can open wider.

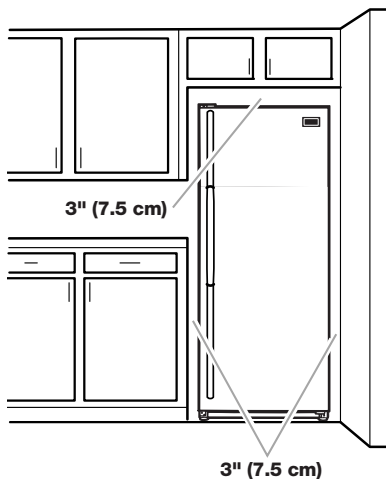

Electrical Requirements

⚠ WARNING



Electrical Shock Hazard

Plug into a grounded 3 prong outlet.

Do not remove ground prong.

Do not use an adapter.

Do not use an extension cord.

Failure to follow these instructions can result in death, fire, or electrical shock.

Before you move your freezer into its final location, it is important to make sure you have the proper electrical connection.

Recommended Grounding Method

A 115 Volt, 60 Hz., AC only, 15- or 20-amp fused, grounded electrical supply is required. It is recommended that a separate circuit serving only your freezer be provided. Use an outlet that cannot be turned off by a switch. Do not use an extension cord.

NOTE: Before performing any type of installation, cleaning, or removing a light bulb, turn knob to “0” on manual defrost models, or press and hold TEMP SETTING for 3 seconds on automatic defrost models to turn off cooling, and then disconnect the freezer from the electrical source.

Style 1—Manual Defrost

Style 2—Automatic Defrost

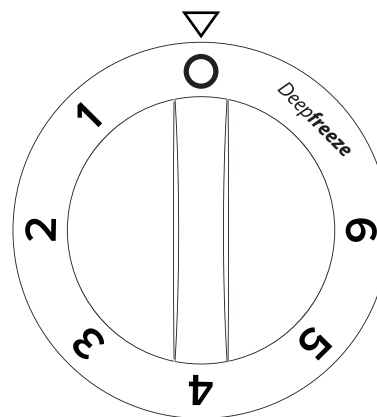

Temp
Setting

Cooling On/Off
Hold 3 Sec

Freezer Door

Tools Needed: 5/16" hex-head socket wrench, 3/8" hex-head socket wrench, flat 2" putty knife.

IMPORTANT:

- All graphics referenced in the following instructions are included later in this section after "Final Steps." The graphics shown are for a right-hand swing door (hinges factory installed on the right).
- If you only want to remove and replace the door, see the "Remove Door and Hinges" and "Replace Door and Hinges."
- Before you begin, turn the control off, and remove food and adjustable door or utility bins from door.

Remove Door and Hinges

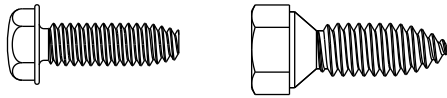

Hinge screws

1. Unplug freezer or disconnect power.
2. Keep the freezer door closed until you are ready to lift it free from the cabinet.
NOTE: Provide additional support for the door while the hinges are being moved. Do not depend on the door magnets to hold the door in place while you are working.
3. Remove the parts for the top hinge as shown in Top Hinge graphic.
4. Lift the freezer door free from the bottom hinge and cabinet and set aside.
5. Remove the four hex-head hinge screws and bottom hinge assembly. See Bottom Hinge graphic.

Reverse Door (optional on some models)

IMPORTANT: If you want to reverse your door so that it opens in the opposite direction, continue with "Reverse Door (optional on some models)" instructions. If you are not reversing the door, see "Replace Door and Hinges."

Cabinet

1. Remove the cabinet hinge hole plugs from the cabinet top and move them to the opposite side hinge holes as shown in Graphic 1.
2. Remove the bottom hinge pin from the hinge bracket.
3. Remove the decals covering the holes on the opposite side of the bottom hinge.
4. Reinstall the bottom hinge pin in the alternate hole in the hinge bracket. See Graphic 2.
5. Reinstall the hinge bracket to the cabinet with the four hex-head hinge screws.

Door

1. Remove the door stop from the bottom of the door.
2. Move the door stop to the opposite side making sure that the hole in the door stop bracket is aligned perfectly with the hole in the door for the bottom hinge pin.
3. Using the screws removed in Step 1, fasten the door stop bracket to the bottom of the door.
4. Tighten all screws. Set aside the door until the bottom hinge is in place.

Replace Door and Hinges

NOTE: Graphic may be reversed if door swing is reversed.

1. Replace the parts for the bottom hinge as shown and tighten screws. See Bottom Hinge graphic. Replace the freezer door.
NOTE: Provide additional support for the door while the hinges are being moved. Do not depend on the door magnets to hold the door in place while you are working.
2. Assemble the parts of the top hinge as shown in the Top Hinge graphic. Do not tighten the screws completely.

Final Steps

1. Check all holes to make sure that hole plugs and screws are in place. Reinstall top hinge cover. See Top Hinge graphic.
2. Using the provided decals, cover the remaining holes located on the opposite side from the bottom hinge.

⚠ WARNING



Electrical Shock Hazard

Plug into a grounded 3 prong outlet.

Do not remove ground prong.

Do not use an adapter.

Do not use an extension cord.

Failure to follow these instructions can result in death, fire, or electrical shock.

3. Plug into a grounded 3 prong outlet.
4. Reset the control. See "Using the Control."
5. Return all removable door parts to door and food to freezer.

Door Removal & Replacement

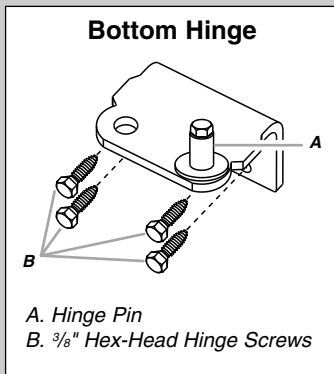
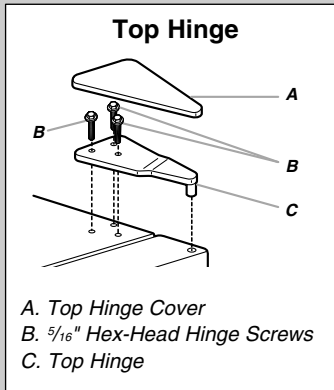

Door Swing Reversal (optional)

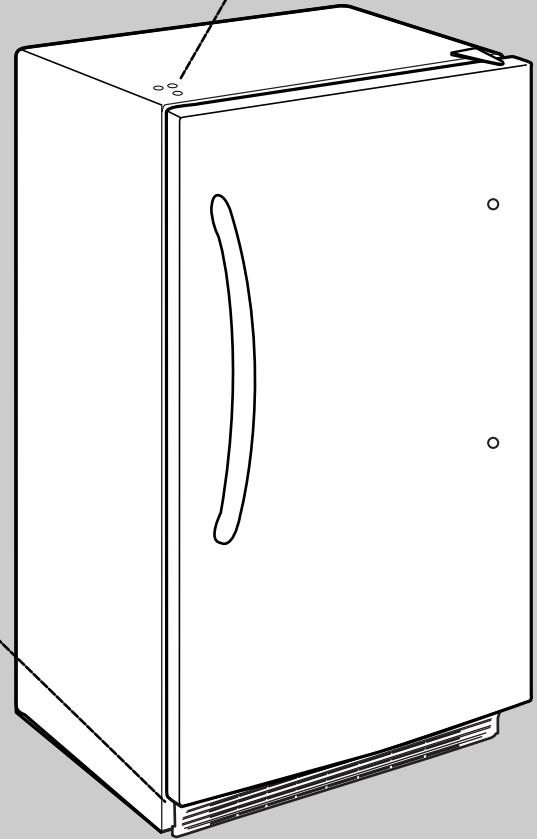
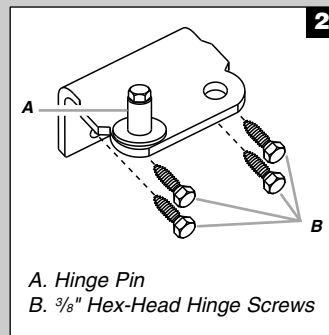
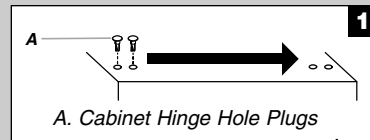

Freezer Leveling and Door Closing

Style 1—without Grille

1. Locate the two front leveling legs taped among the packing materials.
2. Screw these legs into the front holes on the bottom of the freezer. The back of the freezer rests on two fixed supports.
3. Adjust the front legs enough to lift the cabinet up off the floor.
4. Place a leveling tool on top of the freezer first side to side, then front to back. Turn leg counterclockwise to raise a corner. Turn leg clockwise to lower a corner.

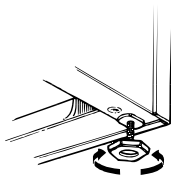

5. Repeat Step 4 until freezer is level.
6. After freezer is fully loaded with food, recheck with level as in Step 4.

Style 2—with Grille

Your freezer has two front adjustable legs, one on each side. The back of the freezer rests on two fixed rollers. The base grille covers the adjustable brake feet and roller assemblies located at the bottom of the freezer below the freezer door. Before making any adjustments, remove the base grille and move the freezer to its final location.

Tools Needed: 1/4" hex driver, Phillips screwdriver

1. Remove the base grille screws. Grasp the grille firmly and pull it toward you. Open the freezer door to access the brake feet.
NOTE: To allow the freezer to roll more easily, raise the brake feet by turning them counterclockwise. The front rollers will be touching the floor.

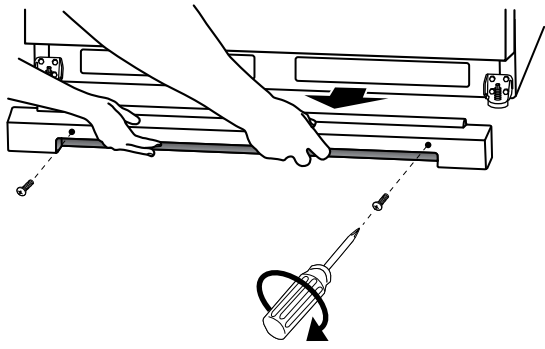

2. Move the freezer to its final location.
3. Lower the brake feet, by turning them clockwise, until the rollers are off the floor and both brake feet are snug against the floor. This keeps the freezer from rolling forward when opening the freezer door.

IMPORTANT: If you need to make further adjustments involving the brake feet, you must turn both brake feet the same amount to keep the freezer level.

4. Make sure the door closes easily. If you are satisfied with the door opening and closing, skip the next section. If, however, the door does not close easily or the door pops open, adjust the tilt.

To Adjust the Cabinet Tilt:

NOTE: Having someone push against the top of the freezer takes some weight off the brake feet. This makes it easier to turn them.

- Open the freezer door. Use a 1/4" hex driver to turn both brake feet clockwise the same amount. This will raise the front of the freezer. It may take several turns to allow the door to close more easily.

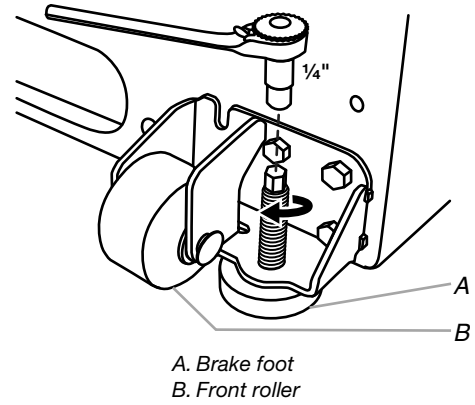

5. Make sure the freezer is steady. If the freezer seems unsteady or rolls forward when the door is pulled open, adjust the brake feet.

To Steady the Freezer:

- Open the freezer door. Using a 1/4" hex driver, turn both brake feet clockwise the same amount until the brake feet are snug against the floor. Check again. If not satisfied, continue to adjust the brake feet by half turns of the screw until the freezer does not roll forward when the door is opened.
6. Replace the base grille by aligning the ends of the grille with the leveling assemblies on each side and snapping the grille into place. Reinstall the Phillips screws.

OPERATING YOUR FREEZER

Ensuring Proper Air Circulation

In order to ensure proper temperature, you need to permit proper airflow in the freezer. As shown in the illustration, cool air enters from the freezer wall and moves down. The air then recirculates through the vent near the bottom.

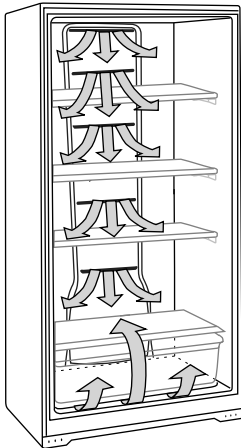

Do not block any of these vents with food packages. If the vents are blocked, airflow will be restricted, and temperature and moisture problems may occur.

IMPORTANT: To avoid odor transfer and drying out of food, wrap or cover foods tightly.

Using the Control

Style I—Manual Defrost Models

Turn the freezer temperature control to 4. This setting is designed to maintain the temperature at or near 0°F (-18°C) under normal operating conditions.

Allow the freezer to cool 6 to 8 hours before filling with frozen food.

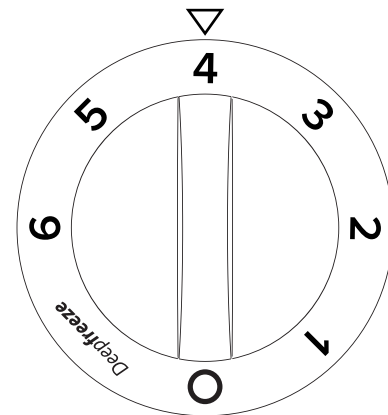

NOTE: When the freezer is first started, the compressor will run constantly until the freezer is cooled. It may take up to 6 or 8 hours (or longer), depending on room temperature and the number of times the freezer door is opened. After the freezer is cooled, the compressor will turn on and off as needed to keep the freezer at the proper temperature.

The outside of your freezer may feel warm. This is normal. The freezer's design and main function is to remove heat from packages and air space inside the freezer. The heat is transferred to the room air, making the outside of the freezer feel warm.

Adjusting Control

- Turn control to a higher number for colder temperatures.
- Turn control to a lower number for less cold temperatures.

Deepfreeze™ (on some models)

This setting causes the freezer to run continuously, driving the freezer temperature to the coldest possible temperature. To activate, adjust the control knob to the Deepfreeze™ setting. Use this feature just before adding large amounts of unfrozen foods. For best food quality, do not exceed 3 lbs (1,361 g) per cubic foot (28.32 L). Return to your normal setting after 24 to 48 hours.

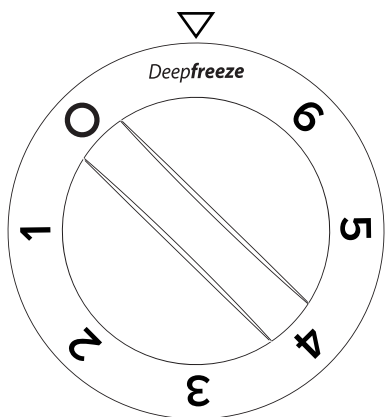

Style 2—Automatic Defrost Models

The temperature control is located at the top front of the freezer compartment.

Temperature Control

For your convenience, the temperature control is preset at the factory. When you first install your freezer, check that the control is still set to the recommended setting as shown.

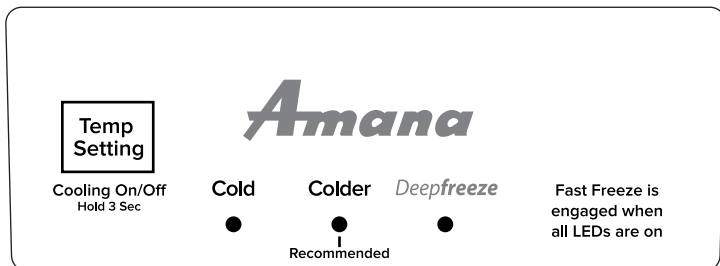

Recommended Setting "Colder"

IMPORTANT:

- The recommended setting is designed to maintain the temperature at or near 0°F (-17.8°C) under normal operating conditions.
- Allow the freezer to cool 6 to 8 hours before filling with frozen food.
- When the freezer is first started, the compressor will run constantly until the freezer is cooled. It may take up to 6 or 8 hours (or longer), depending on room temperature and number of times the freezer door is opened. After the freezer is cooled, the compressor will turn on and off as needed to keep the freezer at the proper temperature.
- The outside of your freezer may feel warm. This is normal. The freezer's design and main function is to remove heat from packages and air space inside the freezer. The heat is transferred to the room air, making the outside of the freezer feel warm.

Adjusting Control

If you need to adjust the temperature in the freezer compartment, press the TEMP SETTING button to display the desired temperature setting (Cold, Colder or Deepfreeze™).

NOTE: Except when starting the freezer, do not adjust the control more than one setting at a time. Wait 24 hours between adjustments for the temperature to stabilize.

Cooling On/Off

Your freezer will not cool when cooling is turned off.

To turn cooling off, press and hold the TEMP SETTING button for 3 seconds. In the off condition, none of the lights on the control panel will be illuminated. The main freezer light bulb will still operate.

To turn cooling on, press and hold the TEMP SETTING button for 3 seconds. When cooling is on, the control panel lights will be illuminated.

Fast Freeze (on some models)

Use this feature before adding large amounts of unfrozen food. For the best food quality, do not exceed 3 lbs (1,361 g) per cu. ft (28.32 L) of freezer space.

To activate Fast Freeze, press the TEMP SETTING button until all the indicator light positions are illuminated simultaneously.

The freezer will remain in the Fast Freeze setting for 24 hours after the extra-low temperature is reached. Once the time has expired, the freezer will return to the previous temperature setting. Fast Freeze may be manually turned off by pressing the TEMP SETTING button to select the desired temperature setting (Cold, Colder or Deepfreeze™).

Freezer Features

This manual covers several different models. The freezer you have purchased may have some or all of the items listed. The locations of the features may not match those of your model.

Refrigerated Shelves—Manual Defrost Models

Your freezer is equipped with refrigerated interior shelves. Packages in direct contact with the shelves will have the best refrigeration. Fresh, unfrozen food packages should be stored directly on the shelves and not on top of already frozen food packages.

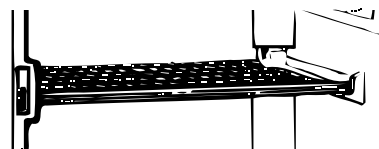

When placing the food packages in your freezer, please remember:

- The cabinet shelves have the best freezing capability. The door shelves and the bottom of the cabinet have a slightly less cold temperature. Therefore, packages sensitive to temperature (meat, poultry, etc.) should not be placed on the door shelves or the freezer bottom.
- Leave some space between the food packages so that cold air can pass over and around them.

Freezer Shelves

Store similar foods together and adjust the shelves to fit different heights. This reduces the time the freezer door is open and saves energy.

To Remove and Replace a Shelf:

1. Remove the shelf by lifting straight up, and pulling the shelf out.

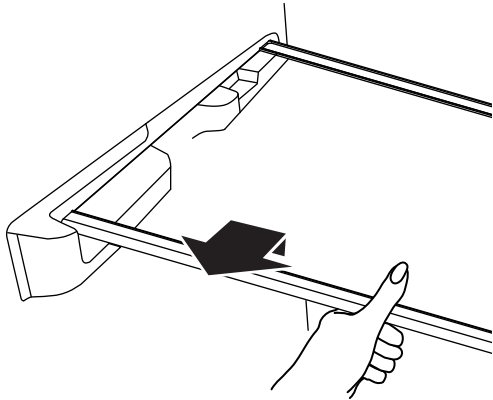

2. Replace the shelf by lowering the shelf onto the supports on the side wall.

Storage Gate (on some models)

To Remove and Replace the Storage Gate:

1. Lift up the top of the gate and out of the supports.
2. Return the gate to original position. Lower the gate into the supports.

CARING FOR YOUR FREEZER

Cleaning Your Frost-Free Freezer (on some models)

⚠ WARNING



Explosion Hazard

Use nonflammable cleaner.

Failure to do so can result in death, explosion, or fire.

Frost-free means that you will not have to defrost your freezer. Frost is removed by air moving and collecting any moisture and depositing it on the cooling coil. The cooling coil periodically warms up enough to melt the frost, and it then flows down to the drain pan (located behind the base grille) where it is evaporated.

Complete cleaning should be done at least once a year.

1. Press and hold TEMP SETTING for 3 seconds or turn knob to "0" to turn off cooling.
2. Unplug freezer or disconnect power.
3. Remove all frozen food. Wrap frozen food in several layers of newspaper and cover with a blanket. Food will stay frozen for several hours. You may also store frozen food in a cooler, additional refrigerator-freezer, or in a cool area.
4. Remove all removable parts from inside, such as shelves, bins, etc.
5. Hand wash, rinse, and dry removable parts and interior surfaces thoroughly. Use a clean sponge or soft cloth and a mild detergent in warm water.
 - Do not use abrasive or harsh cleaners such as window sprays, scouring cleansers, flammable fluids, cleaning waxes, concentrated detergents, bleaches or cleansers containing petroleum products on plastic parts, interior and door liners or gaskets.

Do not use paper towels, scouring pads, or other harsh cleaning tools. These can scratch or damage materials.

- To help remove odors, you can wash interior walls with a mixture of warm water and baking soda (2 tbs to 1 qt [26 g to 0.95 L] of water).
6. Replace the removable parts.
 7. Use the appropriate cleaning method for your exterior finish.

Painted metal: Wash exteriors with a clean sponge or soft cloth and a mild detergent in warm water. Do not use abrasive or harsh cleaners, or cleaners designed for stainless steel. Dry thoroughly with a soft cloth.
 8. For models with condenser coils, clean the condenser coils regularly. Coils may need to be cleaned as often as every other month. This may help save energy.
 - Open the freezer door and remove the base grille by removing 2 Phillips-head screws and pulling the grille toward you.

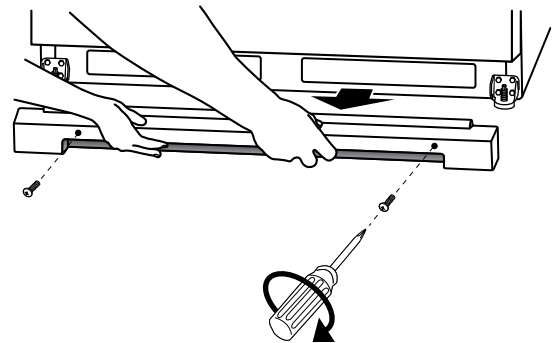

- Use a vacuum with an extended attachment to clean the condenser coils when they are dusty or dirty.
- Replace the base grille by aligning the ends of the grille with the leveling assemblies on each side and snapping the grille into place. Reinstall the screws.

9. Replace all frozen food.
10. Plug in freezer or reconnect power.
11. Set temperature control to desired setting. See "Using the Control."

Defrosting and Cleaning Your Manual Defrost Freezer (on some models)

⚠ WARNING



Explosion Hazard

Use nonflammable cleaner.

Failure to do so can result in death, explosion, or fire.

Defrost and clean your freezer when frost has built up to about ¼" (0.6 cm) thickness, and thoroughly defrost and clean your freezer at least once a year. In high humidity areas, a freezer may need more frequent defrosting and cleaning.

Do not use abrasive cleaners on your freezer. Do not use cleaning waxes, concentrated detergents, bleaches, or cleaners containing petroleum on plastic parts. Damage can occur.

NOTE: The drain cap must be removed before defrosting the freezer and replaced securely afterward.

1. Press and hold TEMP SETTING for 3 seconds or turn knob to "0" to turn off cooling.
2. Unplug freezer or disconnect power.
3. Remove all frozen food. Wrap frozen food in several layers of newspaper and cover with a blanket. Food will stay frozen for several hours. You may also store frozen food in a cooler, an additional refrigerator or freezer, or a cool area.
4. Remove base grille.
 - Open the freezer door and remove the base grille by removing 2 Phillips-head screws and pulling the grille toward you.

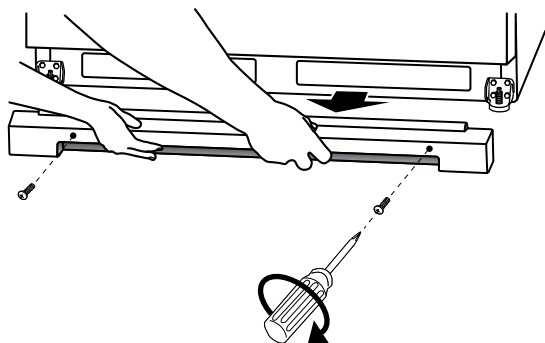

5. Reach under the unit and pull the drain hose out through the opening. The drain hose carries defrost water out of the freezer, and through the area behind the base grille. Place a large shallow pan under the drain hose. Remove the drain cap inside freezer.

NOTE: Check the drain pan frequently to avoid water overflow. Have a second pan handy for easier emptying.

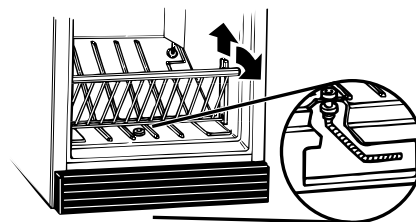

6. Place pans of hot water in freezer with door open to speed melting. Directing air from an electric fan into freezer will also help. Do not place fan or any electrical device in freezer.
7. Use a plastic scraper to remove frost.

NOTE: Do not use an ice pick, knife, or other sharp-pointed tool to defrost freezer. Damage can occur.
8. Wipe water from walls with a towel or sponge.
9. Wash the inside walls with a solution of mild detergent in warm water or 2 tbs (26 mg) baking soda to 1 qt (0.95 L) warm water. Do not use abrasive or harsh cleaners.
10. Rinse well and wipe dry with a clean soft cloth.
11. Use the appropriate cleaning method for your exterior finish.

Painted metal: Wash exteriors with a clean sponge or soft cloth and a mild detergent in warm water. Do not use abrasive or harsh cleaners, or cleaners designed for stainless steel. Dry thoroughly with a soft cloth.
12. For models with a drain system, you should replace the drain hose, drain cap and base grille.
 - Replace the base grille by aligning the ends of the grille with the leveling assemblies on each side and snapping the grille into place. Reinstall the screws.
13. Replace all frozen food.
14. Plug in freezer or reconnect power.
15. Set temperature control to desired setting. See "Using the Control."

Changing the Light Bulb

NOTE: Not all appliance bulbs will fit your freezer. Be sure to replace the bulb with one of the same size, shape, and wattage.

Style I—Manual Defrost Models

1. Unplug freezer or disconnect power.
2. Reach behind the light lens to remove bulb.

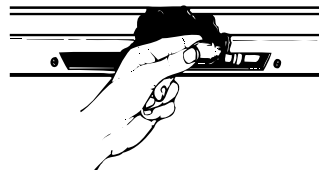

3. Replace bulb with a 40-watt maximum appliance bulb.

NOTE: Do not use an LED or colored light bulb as a replacement.
4. Plug in freezer or reconnect power.

Style 2—Automatic Defrost Models

1. Unplug freezer or disconnect power.
2. Remove the light shield by squeezing the lens from the sides, pushing back and pulling down.

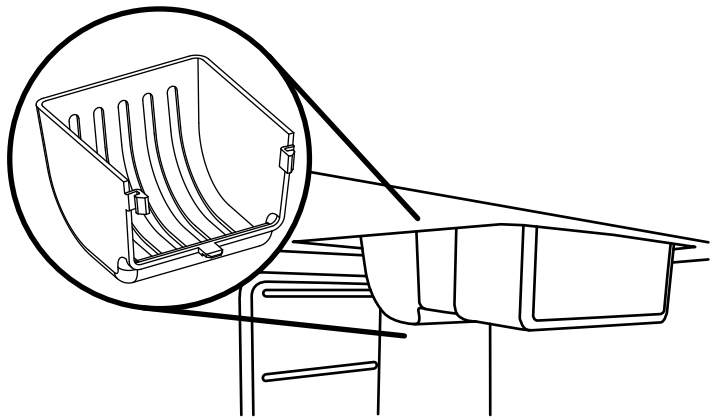

3. Replace bulb with a 40-watt maximum appliance bulb.
NOTE: Do not use an LED or colored light bulb as a replacement.
4. Replace the light shield.
5. Plug in freezer or reconnect power.

Power Interruptions

If the power will be out for 24 hours or less, keep the door closed to help food stay cold and frozen.

If the power will be out for more than 24 hours, do one of the following:

- Remove all frozen food and store it in a frozen food locker.
- If a food locker is not available, consume or can perishable food at once.

REMEMBER: A full freezer stays cold longer than a partially filled one. A freezer full of meat stays cold longer than a freezer full of baked goods. If you see that food contains ice crystals, it may be refrozen, although the quality and flavor may be affected. If the condition of the food is poor, dispose of it.

Moving Care

When you are moving your freezer to a new home, follow these steps to prepare it for the move.

1. Remove all frozen food.
2. Unplug the freezer.
3. Take out all removable parts, wrap them well, and tape them together so they don't shift and rattle during the move.
4. Clean the freezer thoroughly.
5. Tape the freezer shut and tape the electrical cord to the cabinet.

When you get to your new home, refer to the "Installing Your Freezer" and "Operating Your Freezer" sections for information on installation and setting the controls.

PROBLEM SOLVER

First try the solutions suggested here. If you need further assistance or more recommendations that may help you avoid a service call, refer to the warranty page in this manual and scan the code with your mobile device, or visit <http://amana.custhelp.com>. In Canada, visit www.amacanada.ca.

Contact us by mail with any questions or concerns at the address below:

In the U.S.A.:

Amana Brand Home Appliances
Customer eXperience Center
553 Benson Road
Benton Harbor, MI 49022-2692

Please include a daytime phone number in your correspondence.

In Canada:

Amana Brand Home Appliances
Customer eXperience Centre
200 – 6750 Century Ave.
Mississauga, Ontario L5N 0B7

⚠ WARNING



Electrical Shock Hazard

- Plug into a grounded 3 prong outlet.
- Do not remove ground prong.
- Do not use an adapter.
- Do not use an extension cord.
- Failure to follow these instructions can result in death, fire, or electrical shock.

⚠ WARNING



Explosion Hazard

- Use nonflammable cleaner.
- Failure to do so can result in death, explosion, or fire.

PROBLEM	RECOMMENDED SOLUTIONS
Freezer Will Not Operate	<p>Check that the freezer is not running an automatic defrost cycle.</p> <p>Check that it is plugged into a grounded 3 prong outlet.</p> <p>Check that the temperature control is turned on.</p> <p>Replace the fuse or reset the circuit breaker.</p> <p>NOTE: If problems continue, contact an electrician.</p>
Lights Do Not Work	<p>Check that it is plugged into a grounded 3 prong outlet.</p> <p>Check that the light bulb is tight in the socket and is not burned out.</p>
Water in Defrost Drain Pan	<p>It is normal for water to drip into the defrost drain pan when freezer is defrosting.</p> <p>When humidity is high, it is normal for water in the defrost pan to take longer to evaporate.</p>
Motor Seems to Run Too Much	<p>Check that door closes properly.</p> <p>Defrost and clean the freezer to remove excessive frost.</p> <p>Adding a large amount of food warms the freezer causing the freezer to run longer to cool back down. If this is the situation, wait approximately 6 to 8 hours to allow the freezer to reach the correct temperature.</p> <p>Get all items out at one time, keep food organized and close door as soon as possible.</p> <p>Check that the condenser coils are clean.</p> <p>Check that the door gasket is sealed all the way around. If not, contact a qualified person or technician.</p> <p>Check that space around freezer meets air circulation requirements. See "Location Requirements."</p> <p>NOTE: If none of the above, your new freezer will run longer than your old one due to its high-efficiency motor.</p>
Temperature Is Too Warm	<p>Check that air vents are clear. See "Ensuring Proper Air Circulation" for air vent locations.</p> <p>Get all items out at one time, keep food organized and close door as soon as possible.</p> <p>Adding a large amount of food warms the freezer causing the freezer to run longer to cool back down.</p> <p>Check that the temperature control is set correctly for surrounding conditions.</p>
The Door Will Not Close Completely or Is Difficult To Open	<p>Check that there are no food packages blocking the door.</p> <p>On some models, check that the shelves and basket are in the correct position.</p> <p>Check that gaskets are clean. See "Caring for Your Freezer."</p> <p>Check that the freezer is stable. See "Freezer Leveling and Door Closing."</p>
Freezer Makes Loud Buzzing/ Clicking Sound	<p>If the freezer has recently been plugged in or turned on following a defrost or product move, or if there has been an extended power failure, turn off the temperature alarm for the next 24 hours.</p> <p>Adding a large amount of food warms the freezer. It can take several hours for the freezer to return to normal temperature. Turn the temperature alarm off for the next 24 hours.</p>

AMANA® MAJOR APPLIANCE LIMITED WARRANTY

ATTACH YOUR RECEIPT HERE. PROOF OF PURCHASE IS REQUIRED TO OBTAIN WARRANTY SERVICE.

Please have the following information available when you call the Customer eXperience Center:

- Name, address and telephone number
- Model number and serial number
- A clear, detailed description of the problem
- Proof of purchase including dealer or retailer name and address

IF YOU NEED SERVICE:

1. Before contacting us to arrange service, please determine whether your product requires repair. Some questions can be addressed without service. Please take a few minutes to review the Troubleshooting or Problem Solver section of the Use and Care Guide, scan the QR code on the right to access additional resources, or visit <http://amana.custhelp.com>.
2. All warranty service is provided exclusively by our authorized Amana Service Providers. In the U.S. and Canada, direct all requests for warranty service to:

Amana Customer eXperience Center

In the U.S.A., call 1-800-843-0304. In Canada, call 1-800-807-6777.

If outside the 50 United States or Canada, contact your authorized Amana dealer to determine whether another warranty applies.



<http://amana.custhelp.com>

ONE YEAR LIMITED WARRANTY

WHAT IS COVERED

For one year from the date of purchase, when this major appliance is installed, operated and maintained according to instructions attached to or furnished with the product, Amana brand of Whirlpool Corporation or Whirlpool Canada LP (hereafter "Amana") will pay for Factory Specified Replacement Parts and repair labor to correct defects in materials or workmanship that existed when this major appliance was purchased, or at its sole discretion replace the product. In the event of product replacement, your appliance will be warranted for the remaining term of the original unit's warranty period.

YOUR SOLE AND EXCLUSIVE REMEDY UNDER THIS LIMITED WARRANTY SHALL BE PRODUCT REPAIR AS PROVIDED HEREIN. Service must be provided by a Amana designated service company. This limited warranty is valid only in the United States or Canada and applies only when the major appliance is used in the country in which it was purchased. This limited warranty is effective from the date of original consumer purchase. Proof of original purchase date is required to obtain service under this limited warranty.

WHAT IS NOT COVERED

1. Commercial, non-residential, multiple-family use, or use inconsistent with published user, operator or installation instructions.
2. In-home instruction on how to use your product.
3. Service to correct improper product maintenance or installation, installation not in accordance with electrical or plumbing codes or correction of household electrical or plumbing (i.e. house wiring, fuses or water inlet hoses).
4. Consumable parts (i.e. light bulbs, batteries, air or water filters, preservation solutions, etc.).
5. Conversion of products from natural gas or L.P. gas.
6. Damage from accident, misuse, abuse, fire, floods, acts of God or use with products not approved by Amana.
7. Repairs to parts or systems to correct product damage or defects caused by unauthorized service, alteration or modification of the appliance.
8. Cosmetic damage including scratches, dents, chips, and other damage to the appliance finishes unless such damage results from defects in materials and workmanship and is reported to Amana within 30 days.
9. Discoloration, rust or oxidation of surfaces resulting from caustic or corrosive environments including but not limited to high salt concentrations, high moisture or humidity or exposure to chemicals.
10. Food or medicine loss due to product failure.
11. Pick-up or delivery. This product is intended for in-home repair.
12. Travel or transportation expenses for service in remote locations where an authorized Amana servicer is not available.
13. Removal or reinstallation of inaccessible appliances or built-in fixtures (i.e. trim, decorative panels, flooring, cabinetry, islands, countertops, drywall, etc.) that interfere with servicing, removal or replacement of the product.
14. Service or parts for appliances with original model/serial numbers removed, altered or not easily determined.

The cost of repair or replacement under these excluded circumstances shall be borne by the customer.

DISCLAIMER OF IMPLIED WARRANTIES

IMPLIED WARRANTIES, INCLUDING ANY IMPLIED WARRANTY OF MERCHANTABILITY OR IMPLIED WARRANTY OF FITNESS FOR A PARTICULAR PURPOSE, ARE LIMITED TO ONE YEAR OR THE SHORTEST PERIOD ALLOWED BY LAW. Some states and provinces do not allow limitations on the duration of implied warranties of merchantability or fitness, so this limitation may not apply to you. This warranty gives you specific legal rights, and you also may have other rights that vary from state to state or province to province.

DISCLAIMER OF REPRESENTATIONS OUTSIDE OF WARRANTY

Amana makes no representations about the quality, durability, or need for service or repair of this major appliance other than the representations contained in this warranty. If you want a longer or more comprehensive warranty than the limited warranty that comes with this major appliance, you should ask Amana or your retailer about buying an extended warranty.

LIMITATION OF REMEDIES; EXCLUSION OF INCIDENTAL AND CONSEQUENTIAL DAMAGES

YOUR SOLE AND EXCLUSIVE REMEDY UNDER THIS LIMITED WARRANTY SHALL BE PRODUCT REPAIR AS PROVIDED HEREIN. AMANA SHALL NOT BE LIABLE FOR INCIDENTAL OR CONSEQUENTIAL DAMAGES. Some states and provinces do not allow the exclusion or limitation of incidental or consequential damages, so these limitations and exclusions may not apply to you. This warranty gives you specific legal rights, and you also may have other rights that vary from state to state or province to province.