

Electrolux

CONTENTS

- 3
- 9 Before Setting Surface Controls
- 13 Setting Surface Burners
- 14 Before Setting Oven Controls
- 17 Setting Oven Controls
- 26 Care and Cleaning
- 32 Before You Call
- 35 Warranty

PLEASE READ AND SAVE THIS GUIDE

Thank you for purchasing an Electrolux appliance. You've chosen a product that brings with it decades of professional experience and innovation. Ingenious and stylish, it has been designed with you in mind. So whenever you use it, you can be safe in the knowledge that you'll get great results every time.

This Use & Care Guide is part of our commitment to customer satisfaction and product quality throughout the service life of your new appliance. We view your purchase as the beginning of a relationship. To ensure our ability to continue serving you, please use this page to record important product information.

CUSTOMER CARE AND SERVICE

Keep a Record for Quick Reference

Purchase Date

Electrolux model number

Electrolux serial number

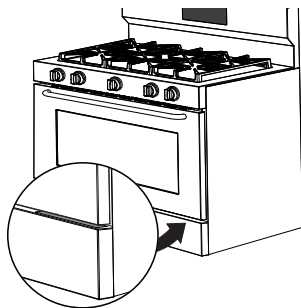

When contacting Service, ensure that you have the following data available. The information can be found on the serial plate. The serial plate is located on top of the range's lower front panel, and can be clearly viewed when door is open.

We recommend the use of original spare parts. Registering your product with Electrolux enhances our ability to serve you. You can register online at www.electroluxappliances.com or by dropping your Product Registration Card in the mail. For toll-free telephone support in the U.S. and Canada: 1-877-4ELECTROLUX (1-877-435-3287).

VISIT OUR WEBSITE FOR ACCESSORIES, CONSUMABLES, AND MORE!

The Electrolux Webshop

In the Electrolux webshop you'll find everything you need to keep all your Electrolux appliances looking spotless and working perfectly. Electrolux offers a wide range of accessories designed and built to the high quality standards you would expect from specialist cookware to cutlery baskets, bottle holders to delicate laundry bags. Visit the webshop at: www.electrolux.com/shop



On the Electrolux Website

Want to learn more about your product or discover additional Electrolux appliances? If so, then check out the link below for product overviews, a list of features, photo galleries, product manuals (complete owner's guide, installation instructions, wiring diagrams, product spec sheets), specifications, reviews, related accessories, and video guides.

For online support and Internet production information, visit <http://www.electroluxappliances.com> www.electrolux.com
1-877-435-3287

All Rights Reserved. Printed in U.S.A

Important Safety Instructions

Read all instructions before using this appliance.

This manual contains important safety symbols and instructions. Please pay attention to these symbols and follow all instructions given.

Do not attempt to install or operate your appliance until you have read the safety precautions in this manual. Safety items throughout this manual are labeled with a **WARNING** or **CAUTION** statement based on the risk type.

Warnings and important instructions appearing in this guide are not meant to cover all possible conditions and situations that may occur. Common sense, caution, and care must be exercised with installing, maintaining, or operating your appliance.

Definitions

 This is the safety alert symbol. It is used to alert you to potential personal injury hazards. Obey all safety messages that follow this symbol to avoid possible injury or death.

WARNING

indicates a potentially hazardous situation which, if not avoided, may result in death or serious injury.

CAUTION

indicates a potentially hazardous situation which, if not avoided, may result in minor or moderate injury.

IMPORTANT! indicates installation, operation, maintenance or valuable information that is not hazard related.

 Indicates a short, informal reference – something written down to assist the memory or for future reference.

WARNING

If the information in this manual is not followed exactly, a fire or explosion may result causing property damage, personal injury, or death.

FOR YOUR SAFETY: Do not store or use gasoline or other flammable vapors and liquids in the vicinity of this or any other appliance.

—WHAT TO DO IF YOU SMELL GAS

- Do not try to light any appliance.
- Do not touch any electrical switch.
- Do not use any phone in your building.
- Immediately call your gas supplier from a neighbor's phone. Follow the gas supplier's instructions.
- If you cannot reach your gas supplier, call the fire department.
- Installation and service must be performed by a qualified installer, servicer, or the gas supplier.

WARNING

Tip Over Hazard

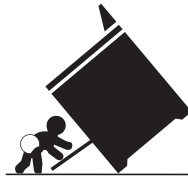

- A child or adult can tip the range and be killed.
- Verify the anti-tip device has been installed to floor or wall.

- Ensure the anti-tip device is re-engaged to floor or wall when the range is moved.
- Do not operate the range without the anti-tip device in place and engaged.
- Failure to follow these instructions can result in death or serious burns to children and adults.



Range leveling leg

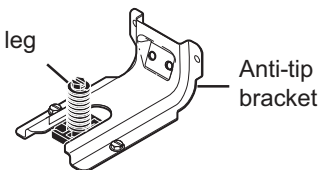

Anti-tip bracket

To check if the anti-tip bracket is installed properly, use both arms to grasp the rear edge of the range back. Carefully attempt to tilt range forward. When properly installed, the range should not tilt forward.

Refer to the anti-tip bracket installation instructions supplied with your range for proper installation.

Save these instructions for future reference.

Important Safety Instructions

Read all instructions before using this appliance.

IMPORTANT INSTRUCTIONS FOR UNPACKING AND INSTALLATION

IMPORTANT - Read and follow the below instructions and precautions for unpacking, installing, and servicing your appliance:

Remove all tape and packaging before using the appliance. Destroy the carton and plastic bags after unpacking the appliance. Never allow children to play with packaging material. Do not remove the wiring label and other literature attached to the appliance. Do not remove model/serial number plate.

Cold temperatures can damage the electronic control. When using this appliance for the first time, or when the appliance has not been used for an extended period of time, be sure the appliance has been in temperatures above 32°F (0°C) for at least 3 hours before turning on the power to the appliance.

Never modify or alter the construction of the appliance by removing the leveling legs, panels, wire covers, anti-tip brackets/screws, or any other part of the appliance.

Be sure to have an appropriate foam-type fire extinguisher available, visible, and easily accessible located near the appliance.

⚠ WARNING

Air curtain or other overhead range hoods which operate that operate by blowing a downward air flow onto a range or cooktop, shall not be used in conjunction with gas ranges or cooktops other than when the range or cooktop and hood have been designed, tested, and listed by an independent test laboratory for use in combination with each other.

GROUNDING INSTRUCTIONS

⚠ WARNING

Avoid fire hazard or electrical shock. Failure to follow this warning may cause serious injury, fire, or death.

⚠ WARNING

Avoid fire hazard or electrical shock. Do not use an adapter plug, use an extension cord, or remove grounding prong from the power cord. Failure to follow this warning may cause serious injury, fire, or death.

Proper Installation—Be sure your appliance is properly installed and grounded by a qualified technician. In the United States, install in accordance with the National Fuel Gas Code ANSI Z223.1/NPFA No. 54, latest edition and National Electrical Code NFPA No. 70 latest edition, and local electrical code requirements. In Canada, install in accordance with CAN/CGA B149.1 and CAN/CGA B149.2 and CSA Standard C22.1, Canadian Electrical code, Part 1-latest editions and local electrical code requirements. Install only per installation instructions provided in the literature package for this appliance.

For personal safety, this appliance must be properly grounded. For maximum safety, the power cord must be securely connected to an electrical outlet or junction box that is the correct voltage, is correctly polarized and properly grounded, and protected by a circuit breaker in accordance with local codes.

It is the personal responsibility of the consumer to have the appropriate outlet or junction box with the correct, properly grounded wall receptacle installed by a qualified electrician. It is the responsibility and obligation of the consumer to contact a qualified installer to assure that the electrical installation is adequate and is in conformance with all local codes and ordinances.

This appliance is equipped with a 4-prong grounding plug for your protection against shock hazard and should be plugged directly into a properly grounded receptacle. Do not cut or remove the grounding prong from this plug.

Save these instructions for future reference.

Important Safety Instructions

Read all instructions before using this appliance.

For personal safety, the appliance must be properly grounded. For maximum safety, the power cord must be plugged into an electrical outlet that is correctly polarized and properly grounded.

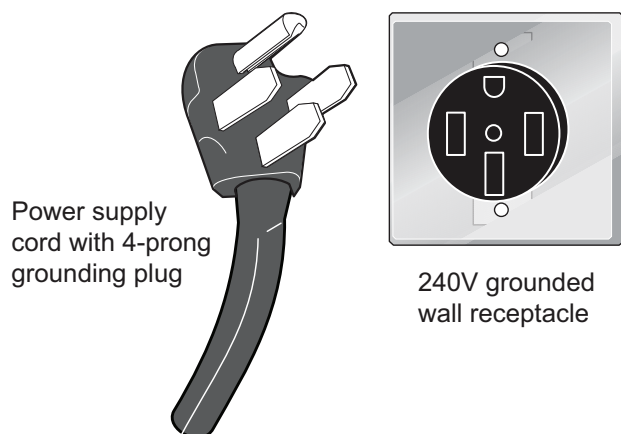

Power supply cord with 4-prong grounding plug

240V grounded wall receptacle

If a 2-prong wall receptacle is the only available outlet, it is the personal responsibility of the consumer to have it replaced with a properly grounded 4-prong wall receptacle, installed by a qualified technician.

Conversion to (L.P.) Gas

This appliance allows for conversion to Liquefied Petroleum (L.P.) Gas.

⚠ WARNING

Personal injury or death from electrical shock may occur if the conversion to L.P. gas is not made by a qualified installer or electrician. Any additions, changes or conversions required in order for this appliance to satisfactorily meet the application needs must be made by a qualified technician.

If L.P. conversion is needed, contact your local L.P. Gas provider for assistance.

See the installation instructions packaged with this appliance for complete installation and grounding instructions.

IMPORTANT INSTRUCTIONS FOR USING THE APPLIANCE

⚠ WARNING

Storage In or On Appliance—Flammable materials should not be stored in an oven or microwave, near surface burners or elements, or in the storage or warmer drawer (if equipped). This includes paper, plastic, and cloth items, such as cookbooks, plastic ware, and towels, as well as flammable liquids. Do not store explosives, such as aerosol cans, on or near the appliance.

⚠ WARNING

Do not leave children alone - Children should not be left alone or unattended in the area where appliance is in use. They should never be allowed to sit or stand on any part of the appliance, including the storage drawer, lower broiler drawer, warmer drawer, or lower double oven.

⚠ WARNING

Do not store items of interest to children in the cabinets above the appliance or on the backguards of ranges. Children climbing on or near the appliance to reach items could be seriously injured.

⚠ WARNING

Do not allow children to climb or play around the appliance. The weight of a child on an open over door may cause the appliance to tip, resulting in serious burns or other injury. An open drawer when hot may cause burns.

⚠ WARNING

Stepping, leaning, or sitting on the door or drawers of this appliance can result in serious injuries and also cause damage to the appliance.

⚠ WARNING

Never cover any slots, holes, or passages in the oven bottom or cover an entire oven rack with any materials, such as aluminum foil or

Save these instructions for future reference.

Important Safety Instructions

Read all instructions before using this appliance.

aftermarket oven liners. Aluminum foil and other liners may trap heat, causing a fire hazard

⚠ WARNING

Do not use oven or warmer drawer (if equipped) for storage.

⚠ WARNING

Never use your appliance as a space heater to heat or warm the room. Doing so may result in carbon monoxide poisoning and overheating of the appliance.

⚠ CAUTION

When heating fat or grease, watch it closely. Grease may catch fire if it becomes too hot.

⚠ CAUTION

Do not use water or flour on grease fires. Smother fire or flame or use dry chemical or foam-type extinguisher. Cover the fire with a pan lid or use baking soda.

⚠ CAUTION

Use dry potholders. Moist or damp potholders on hot surfaces may result in burns from steam. Do not let potholders touch hot cooking areas. Do not use towels or other bulky cloths.

⚠ CAUTION

Do not heat unopened food containers - Build-up of pressure may cause container to burst and result in injury.

⚠ CAUTION

Wear proper apparel - Loose-fitting or hanging garments should never be worn while using the appliance. Do not let clothing or other flammable materials contact hot surfaces.

⚠ CAUTION

Do not touch surface burners or elements, areas near these burners or elements, interior surfaces of the oven, or the warmer drawer (if equipped). Surface burners and elements may be hot even though they appear cool. Areas near surface burners and elements may become hot enough to cause burns.

During and after use, do not touch, or let clothing or other flammable materials touch these areas until they are cool. These areas may include the cooktop, surfaces facing the cooktop, oven vent areas, oven door, and oven window.

⚠ CAUTION

Do not attempt to operate the appliance during a power failure. If the power fails, always turn off the appliance. If the appliance is not turned off and the power resumes, electric surface elements may resume operation when power is restored. Once the power resumes, reset the clock and the oven function.

IMPORTANT INSTRUCTIONS FOR USING YOUR GAS COOKTOP

⚠ CAUTION

Use Proper Flame Size — Adjust flame size so it does not extend beyond the edge of the utensil. The use of undersized utensils will expose a portion of the burner flame to direct contact and may result in ignition of clothing. Proper relationship of utensil to flame will also improve efficiency.

Know which knob or key controls each surface heating area. Place cookware with food on the cooking area before turning it on. Turn the cooking area off before removing the cookware.

Use proper pan size. This appliance is equipped with one or more surface units of different sizes. Select cookware with flat bottoms that match the surface unit heating element. The use of undersized cookware may expose a portion of the flame to direct contact and may result in the ignition of clothing or other items. Using the proper cookware on the cooking areas will improve efficiency.

Always turn knob to the full LITE position when igniting top burners. Visually check that burner has lit. Then adjust the flame so it does not extend beyond the edge of the utensil.

To reduce the risk of burns, ignition of flammable materials, and spillage due to unintentional contact with the utensil, the

Save these instructions for future reference.

Important Safety Instructions

Read all instructions before using this appliance.

handle of the utensil should be positioned so that it is turned inward, and does not extend over adjacent surface burners.

Never leave surface burners unattended at high heat settings — Boil overs cause smoking and greasy spill overs that may ignite, or a pan that has boiled dry may melt.

Glazed cooking utensils — Only certain types of glass, glass/ceramic, ceramic, earthenware, or other glazed utensils are suitable for cook top service without breaking due to the sudden change in temperature. Check the manufacturer's recommendations for cook top use.

When you are flaming foods under a ventilating hood, turn the fan on.

IMPORTANT INSTRUCTIONS FOR USING YOUR OVEN

Protective liners—Do not use aluminum foil, aftermarket oven liners, or any other materials or devices to line oven bottom, oven racks, or any other part of the appliance. Only use aluminum as recommended for baking, such as lining cookware or as a cover placed on food. Any other use of protective liners or aluminum foil may result in a risk of electric shock or fire or a short circuit.

Use care when opening oven door, lower oven door, or warmer drawer (some models). Stand to the side of the appliance when opening the door of a hot oven. Let hot air or steam escape before you remove or replace food in the oven.

Keep oven vent ducts unobstructed. Touching surfaces in this area when the oven is on may cause severe burns. Do not place plastic or heat-sensitive items on or near the oven vent. These items can melt or ignite.

Placement of oven racks - Always place oven racks in desired location while oven is cool. If rack must be moved while oven is hot, do not let potholder contact hot burner or element in oven. Use potholders and grasp the rack with

both hands to reposition. Remove all cookware and utensils before moving the rack.

Do not use a broiler pan without its insert. Broiler pans and inserts allow dripping fat to drain away from the high heat of the broiler. Do not cover the broiler insert with aluminum foil; exposed fat and grease could ignite.

Do not cook food on the oven bottom. Always cook in proper cookware and always use the oven racks.

IMPORTANT INSTRUCTIONS FOR CLEANING YOUR APPLIANCE

⚠ CAUTION

Before manually cleaning any part of the appliance, be sure all controls are turned off and the appliance is cool. Cleaning a hot appliance can cause burns.

Clean the appliance regularly to keep all parts free of grease that could catch fire. Do not allow grease to accumulate. Greasy deposits in the fan could catch fire.

Always follow the manufacturer's recommended directions for use of kitchen cleaners and aerosols. Be aware that excess residue from cleaners and aerosols may ignite causing damage and injury.

Clean ventilating hoods frequently - Grease should not be allowed to accumulate on hood or filter. Follow the manufacturer's instructions for cleaning vent hoods.

Save these instructions for future reference.

Important Safety Instructions

Read all instructions before using this appliance.

Remove the oven door from any unused oven if it is to be stored or discarded.

IMPORTANT INSTRUCTIONS FOR SELF CLEANING OVENS

Do not clean the oven door gasket. The door gasket is essential for a good seal. Care should be taken not to rub, damage, or move the gasket.

Do not use oven cleaners. No commercial oven cleaner or oven liner protective coating of any kind should be used in or around any part of the appliance.

Before using self clean, remove the broiler pan, any food, utensils, and cookware from the oven, storage drawer or warming drawer (if equipped). Remove oven racks unless otherwise instructed.

Use the self clean cycle to clean only the parts listed in this manual.

Some birds are extremely sensitive to the fumes given off during the self clean cycle of any oven. Move birds to another well-ventilated room.

IMPORTANT INSTRUCTIONS FOR SERVICE AND MAINTENANCE

Do not repair or replace any part of the appliance unless specifically recommended in the manuals. All other servicing should be done only by a qualified technician. This reduces the risk of personal injury and damage to the appliance.

Always contact your dealer, distributor, service agent, or manufacturer about problems or conditions you do not understand.

Ask your dealer to recommend a qualified technician and an authorized repair service. Know how to disconnect the power to the appliance at the circuit breaker or fuse box in case of an emergency.

Do not touch a hot oven light bulb with a damp cloth. Doing so could cause the bulb to break. Handle halogen lights (if equipped) with paper towels or soft gloves. Disconnect the appliance or shut off the power to the appliance before removing and replacing the bulb.

Important Safety Notice - The California Safe Drinking Water and Toxic Enforcement Act requires the governor of California to publish a list of substances known to cause cancer, birth defects, or other reproductive harms, and requires businesses to warn customers of potential exposures to such substances.

Save these instructions for future reference.

BEFORE SETTING SURFACE CONTROLS

Gas Surface Burners

Your built-in range is equipped with gas surface burners with different BTU ratings. The ability to heat food quicker and in larger volumes increases as the burner size increases (Figure 1).

Regardless of size or location, always select cookware that is suitable for the amount and type of food being prepared. Select a burner and flame size appropriate to the pan. Never allow flames to extend beyond the outer edge of the pan.

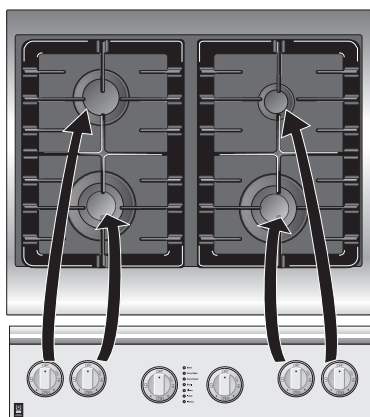

Figure 1: Burner controls and location

Burner Caps and Burner Grates Assembly

⚠ CAUTION

To prevent flare-ups use the cooktop with all burner caps properly installed.

Placement of burner caps

IMPORTANT! Your new range comes with two styles of burners.

- Follow the instructions carefully when placing caps on burners as shown in Figure 2.

Place a burner cap on each burner head, matching the cap size to the head size. The cap for each burner has an inner locating ring which centers the cap correctly on the burner head. Be sure that all the burner caps and burner heads are correctly placed before using your appliance.

Make sure each burner cap is properly aligned and level.

Turn the burner on to determine if it will light. If the burner does not light, contact the installer. Do not service the sealed burner yourself.

ATTENTION: Do not slide the burner caps on the cooktop, doing so can damage the surface.

Setting Regular Burner Caps

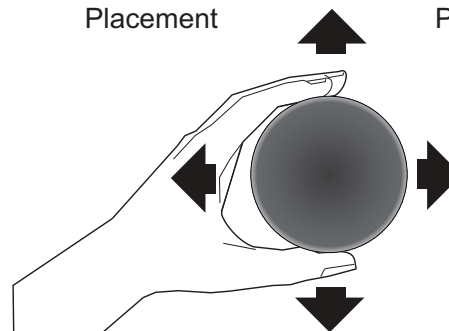
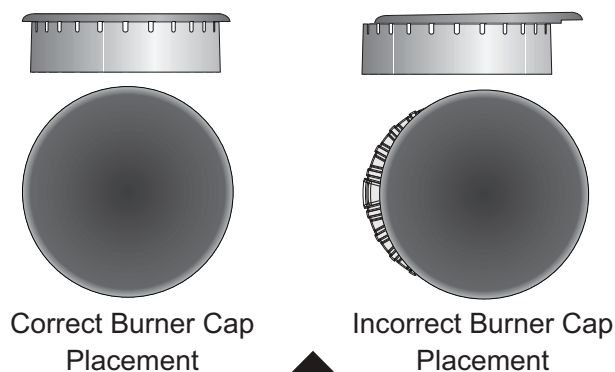
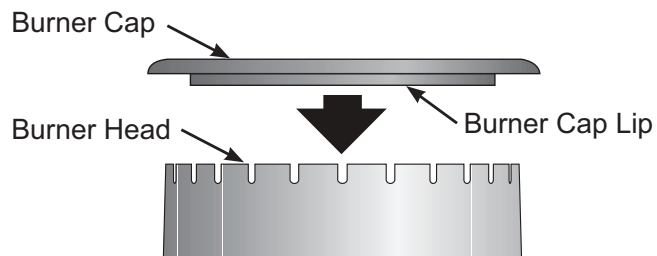

Figure 2: Placing cap properly on burner head

Assembling the G5 burners

IMPORTANT! For proper ignition: **Burner Ring Alignment Tab Must Align with Burner Base Alignment Tab Slot.**

NOTE: When the burner ring is properly seated, it will click into place. When the burner cap is properly set in place it should not move out of the recessed area of the burner head.

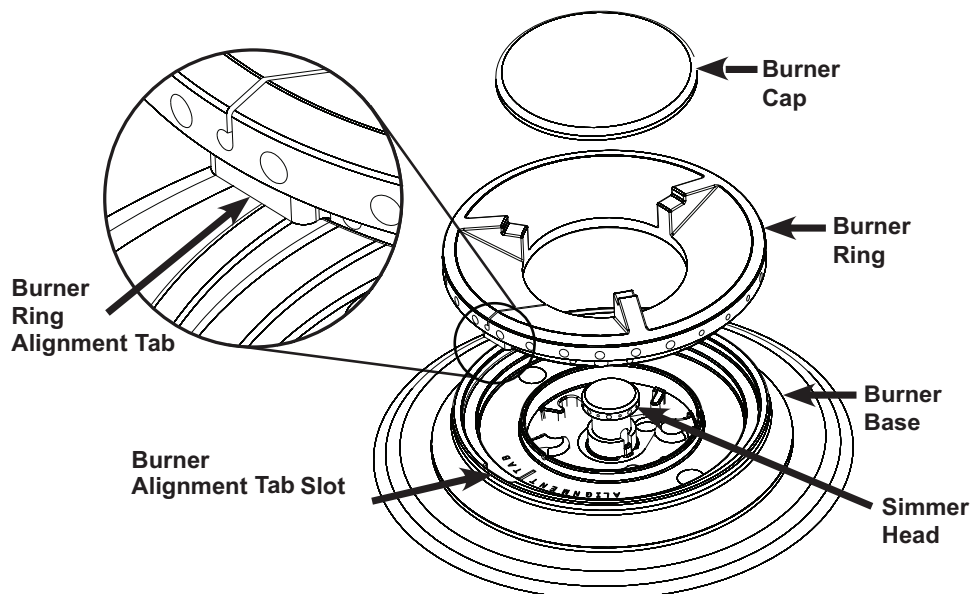

Figure 3: Make sure burner cap and ring are secure before attempting to light the burner.

Installing Burner Grates

⚠ CAUTION

Do not use surface burners without burner caps and grates properly installed. Missing pieces or improper installation may lead to spills, burns, or damage to your range and cookware.

⚠ CAUTION

Make sure the burner grates are properly placed on the cooktop before using the surface burners. The grates are designed to rest inside the recess on the cooktop. To install burner grates, place grates flat-side down and align into the cooktop recess. Grates should rest flush against each other and against the sides of the recess (See Figure 4).

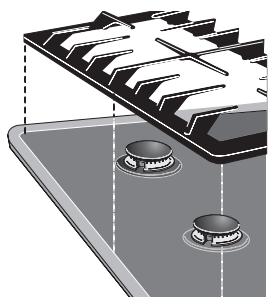

Figure 4: How to properly place burner grates

Home Canning

Be sure to read and observe all the following points when home canning with your appliance.

Check with the United States Department of Agriculture (USDA) website and be sure to read all the information they have available and follow their recommendations for home canning procedures.

- Use only quality flat bottom canners when home canning. Use a straight-edge to check canner bottom.
- When home canning, use only a completely flat bottom canner with no ridges that radiate from the bottom center.
- Be sure the diameter of the canner does not exceed 1 inch beyond the grate.
- Start with hot tap water to bring water to boil more quickly.
- Use the highest heat setting when first bringing the water to a boil.
- Once boiling is achieved, reduce heat to lowest possible setting to maintain that boil.

Setting Proper Burner Flame Size

⚠ CAUTION

Never extend the flame beyond the outer edge of the cooking utensil. A higher flame wastes energy and increases your risk of being burned by the flame (Figure 5).

The color of the flame is the key to proper burner adjustment. A good flame is clear, blue and hardly visible in a well-lighted room. Each cone of flame should be steady and sharp. Adjust or clean burner if flame is yellow-orange.

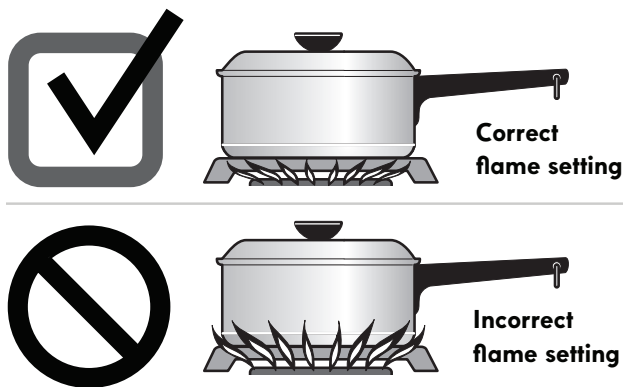

Figure 5: How to set flame for efficient cooking

Using Proper Cookware

⚠ CAUTION

Do not place flammable items such as plastic salt and pepper shakers, spoon holders or plastic wrappings on the cooktop when it is in use. These items could melt or ignite. Potholders, towels or wooden spoons could catch fire if placed too close to the range cooktop.

⚠ CAUTION

Do not place aluminum foil, or any material that can melt on the cooktop. If these items melt they may damage the cooktop.

For best cooking results, cookware should have flat bottoms that rest level on the burner grate. Before using cookware, check for flatness by rotating a ruler across the bottom of the cookware (Figure 6).

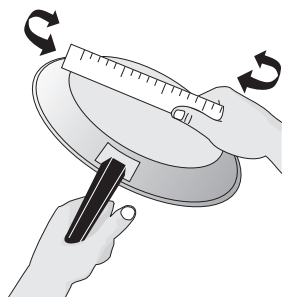

Figure 6: Check for flat bottom cookware

Cookware Material Types

The most popular materials available are:

- Aluminum - Excellent heat conductor. Some types of food will cause it to darken (Anodized aluminum cookware resists staining and pitting).
- Copper - Excellent heat conductor but discolors easily.
- Stainless - Slow heat conductor with uneven cooking results. Is durable, easy to clean and resists staining.
- Cast Iron - A slow heat conductor; however, it will retain heat very well. Cooks evenly once cooking temperature is reached.
- Porcelain - enamel on metal - Heating characteristics will vary depending on base material.
- Glass - Slow heat conductor.

CORRECT



- Flat bottom and straight sides.
- Tight fitting lids.
- Weight of handle does not tilt pan. Pan is well balanced.
- Pan sizes match the amount of food to be prepared.
- Made of material that conducts heat well.
- Easy to clean.

INCORRECT



- Pan overhangs unit by more than 1" (2.5 cm).



- Heavy handle tilts pan.



- Flame extends beyond unit.



Figure 7: Cookware recommendations

Please note: The size and type of utensil used and the amount and type of food being cooked will influence the burner flame setting needed for best cooking results.

Specialty pans such as lobster pots, griddles and pressure cookers may be used but must conform to the above recommended cookware requirements.

IMPORTANT! Never place or straddle a cooking utensil over two different surface cooking areas heating at the same time. This can cause uneven heating results.

Using a Griddle

A griddle (optional) is intended for direct food cooking and can be used on both sides. Do not use pans or other cookware on the griddle. Doing so could damage the finish. With the griddle in position over the burners, set the griddle on top of the grates.

A griddle can be purchased as an accessory by ordering online at www.electrolux-store.com/cooking-accessories.html.

⚠ CAUTION

Always place the griddle on the grate before lighting the burner. Be sure the griddle is positioned correctly and stable before use to prevent hot spills and possible burns.

⚠ CAUTION

Always use potholders to remove the griddle from the grate. Allow the griddle to cool before removing. Do not set a hot griddle on surfaces that cannot withstand high heat, such as counter tops.

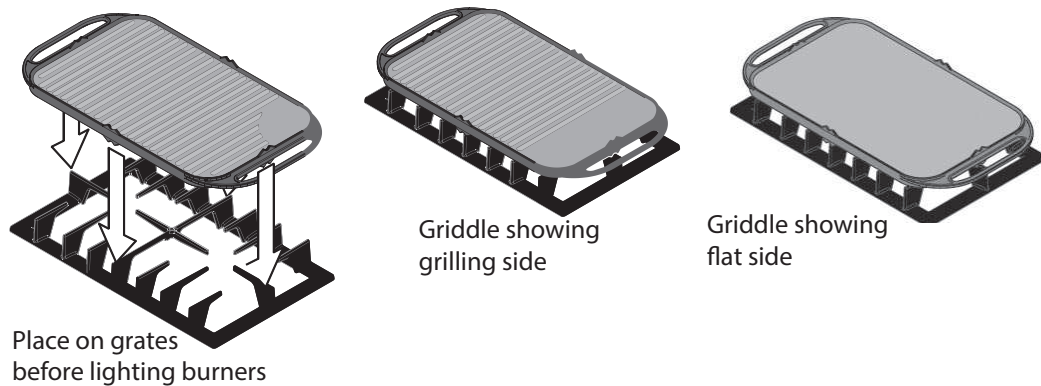

Using a Wok

Figure 8: Use extra care when setting the wok stand onto the burner grates and test stability before using

Always position Wok Stand with notch toward center of burner grate as shown. Lower onto grate.

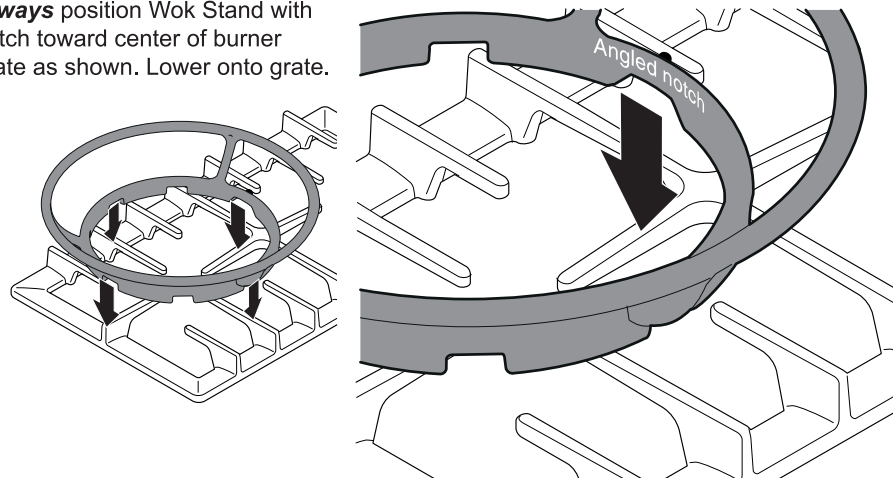

IMPORTANT! Do not use a wok if it is equipped with a metal ring that extends beyond the burner grates. This ring traps heat, and the surface unit and cooktop surface could be damaged as a result.

- Woks with flat bottoms suitable for use on your cooktop are available in most cookware or hardware stores.
- Round bottomed woks (with a support ring that does not extend beyond the burner grates) may also be used. The metal ring was designed to support the wok safely when it is filled with large amounts of liquids (soup making) or fat (frying).
- **Wire trivets:** Do not use wire trivets. Cookware bottoms must be in direct contact with the grates.

SETTING SURFACE BURNERS

Your gas appliance is equipped with different sized surface burners (Figure 9). The ability to heat food quicker and in larger volumes increases as the burner size increases. It is important to select cookware that is suitable for the amount and type of food being prepared.

- The smaller **simmer burner** is best suited for simmering delicate sauces, etc.
- Use **standard size burners** for most cooking needs.
- **Larger power burners** are recommended for bringing large quantities of liquid to temperature and when preparing larger quantities of food.

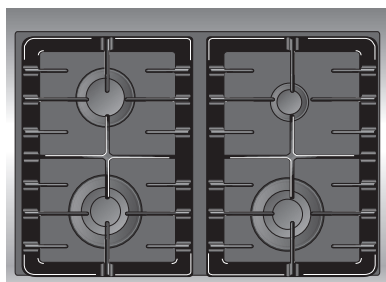



Figure 9: Typical burner sizes

IMPORTANT!

- Do not cook with the surface control knob left in the Lite position. The electronic igniter will continue to spark if the control knob setting remains in the  position.
- When setting any surface control knob to the  position, all electronic surface igniters will spark at the same time. However, only the surface burner you are setting will ignite.
- Never place or straddle a cooking utensil over two different surface cooking areas at the same time, unless the cookware was designed for that purpose (such as griddles). This can cause uneven heating results.
- In the event of an electrical power outage, the surface burners can be lit manually. Use caution when lighting surface burners manually. To light a surface burner, hold a lit match to the burner head, then slowly turn the surface control knob to Lite. After burner lights push in and turn knob to desired setting.
- When operating the oven, it is possible for residual heat from the oven to build-up and over time to eventually transfer to the surface control knobs located directly above the oven door.

CAUTION

Do not place flammable items such as plastic salt and pepper shakers, spoon holders or plastic wrappings on the cooktop when it is in use. These items could melt or ignite. Potholders, towels or wooden spoons could catch fire if placed too close to the range cooktop. Do not place aluminum foil, or any material that can melt on the range cooktop. If these items melt they may permanently damage the cooktop surface.

To set surface burners:

1. Place cooking utensil on center of surface burner grate. Be sure the cooking utensil sets stable on the burner grate.
2. Push the desired surface control knob in and turn counter-clockwise out of the **OFF** position and rotate to the  position (Figure 10). Visually check that the burner has lit.
3. Once the burner has a flame, turn the control knob counter-clockwise to the desired flame size. Use the control markings and adjust the flame as needed.

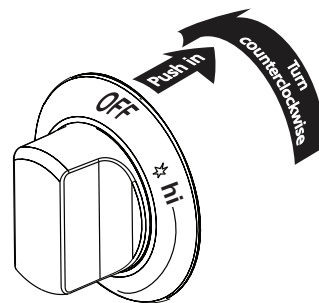

Figure 10: Correct way to set burners

For most cooking:

Start on the highest setting and then turn to a lower setting to complete cooking. Use the recommendations below as a guide for determining proper flame size for various types of cooking (Table 1).

For deep fat frying:

Use a thermometer and adjust the surface knob accordingly. If the fat is too cool, the food will absorb the fat and be greasy. If the fat is too hot, the food will brown so quickly that the center will be under cooked. Do not attempt to deep fat fry too much food at once as the food will neither brown or cook properly.

Table 1: Suggested flame settings

| Flame size ¹⁾ | Type of cooking |
|--------------------------|---|
| High flame | Start most foods, bring water to a boil, pan broiling |
| Medium flame | Maintain a slow boil, thicken sauces, gravies, steaming |
| Low flame | Keep foods cooking, poaching and stewing |

- 1) These settings are based on medium weight metal or aluminum pans with lids. Settings may vary when using other types of pans.

BEFORE SETTING OVEN CONTROLS

Oven Vent Location

The oven vent is located in the front of the oven just below the burner controls. When the oven is in use, warm air passes through this vent for proper air circulation and provides good baking results. Steam or moisture may appear near the oven vent. This is normal. Do not block this vent.

IMPORTANT! Some models are equipped with a cooling fan that runs during the cooking process to cool internal electronic components. It is normal for this fan to continue to run for an extended period of time, even when the oven is off.

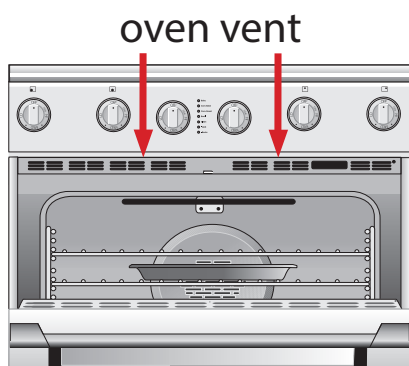

Figure 11: Oven vent location

CAUTION

Protective liners — Do not line the oven walls, racks, bottom or any other parts of the range with aluminum foil. Doing so will alter heat distribution, produce poor baking results, and may cause permanent damage to the oven interior. During self clean temperatures the oven will be hot enough to melt foil.

- Use aluminum foil only as recommended in this manual. Improper installation or use of these liners may result in risk of electric shock or fire.
- Always use potholders or oven mitts when removing food or adjusting the oven racks. Wait until the oven has completely cooled if possible. Oven racks may be very hot and may cause burns.
- Remove all oven racks and rack ladders before starting a self clean cycle. If oven racks are left inside the oven during a cleaning cycle, the slide ability of the Luxury-Glide™ oven racks may be damaged and all of the oven racks will lose their shiny finish. Clean oven racks according to the instructions provided in the “Care and Cleaning” section.

Oven Racks

Your appliance comes with the following rack types (See Figure 12 for the following descriptions):

- Flat handle oven racks are used for most cooking needs and can be placed in most oven rack positions.
- The fully extendable Luxury-Glide™ oven rack allows the user to effortlessly extend food away from the oven. It has glide tracks that allow the rack to be pulled away from the oven without rubbing the sides of the oven wall.
- For ease of removal, racks should not be placed in adjacent rack positions.

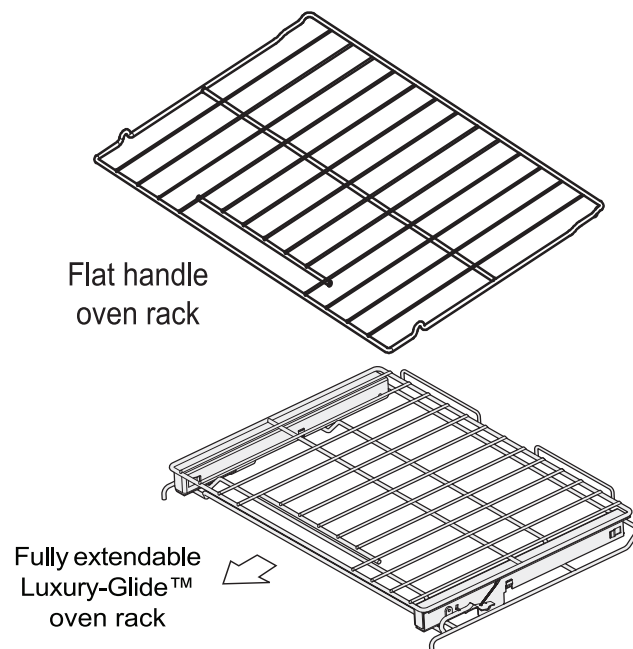

Figure 12: Rack types

Arranging, Removing, and Replacing Oven Racks

IMPORTANT! Remove all oven racks, rack ladders, and any other accessories from the oven before starting a self clean cycle.

- To arrange - Always arrange the oven racks when the oven is cool (prior to operating the oven).
- To remove - pull the oven rack straight forward until it reaches the stop position. Lift up front of oven rack slightly and slide out. For ease of removal, racks should not be placed in adjacent rack positions.
- To replace - place the oven rack on the rack guides on the oven walls. Tilt the front of the rack upward slightly and slide the oven rack back into place.
- To prevent possible damage to the oven, do not attempt to close the oven door until all oven racks are fully positioned inside the oven cavity.

Installing Oven (Ladder) Rack Supports

IMPORTANT! Always install oven rack support before turning on the oven (when the oven is cool).

To aid installation of the porcelain oven rack supports, apply a thin layer of cooking oil to all the prongs of the supports shown below.

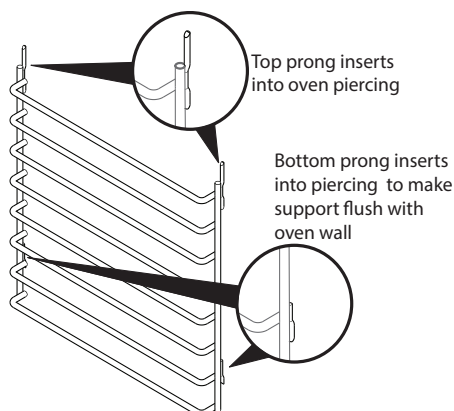

To install oven rack supports:

1. Hold the oven rack support at a slight angle and insert prongs into the holes at the top of the oven cavity (Arrow 1).
2. Lift the rack into the top holes, aligning the bottom prongs with the bottom holes (Arrow 2).
3. Once the upper prongs are in place, hold the oven rack support flush with the oven side and insert the bottom prongs into the bottom holes (Arrow 3).
4. Slide the bottom prongs down into the lower holes. Some force may be required to set the rack into place (Arrow 4).

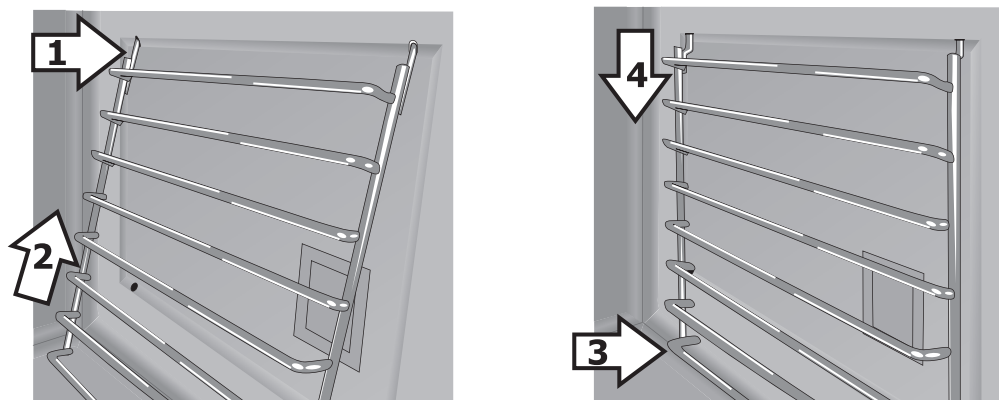

Note: To remove the ladder rack support for a self-clean cycle, reverse the order used when installing the ladder rack supports.

Luxury Glide™ oven racks

IMPORTANT! Remove all oven racks before starting a self clean cycle. If oven racks are left inside the oven during a cleaning cycle, the slide ability of the Luxury-Glide™ oven racks may be damaged and all of the oven racks will lose their shiny finish. Clean oven racks according to the instructions provided in the Care and Cleaning section.

The fully extendable **Luxury Glide™** rack makes food preparation easier. This oven rack has glide tracks that allow the rack to be pulled away from the oven without rubbing the sides of the oven wall.

The Luxury Glide™ rack installs like all other oven racks. Before sliding the rack all the way in, lift the back of the rack slightly to set the rack past the glide stop position. Be sure to slide the rack all the way in so that the back of the rack stops by touching the vertical support of the ladder rack.

The glide portion of the rack can be easily pulled in and out in this position while the frame of the rack remains locked into the ladder supports. This allows bakeware to remain in place on the Luxury Glide™ rack and slide out easily to check food items without removing them from the oven.

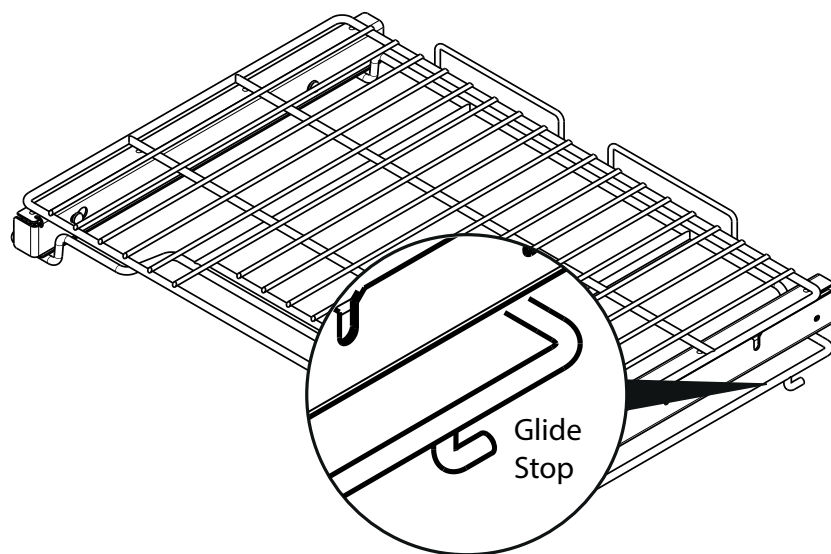

SETTING OVEN CONTROLS

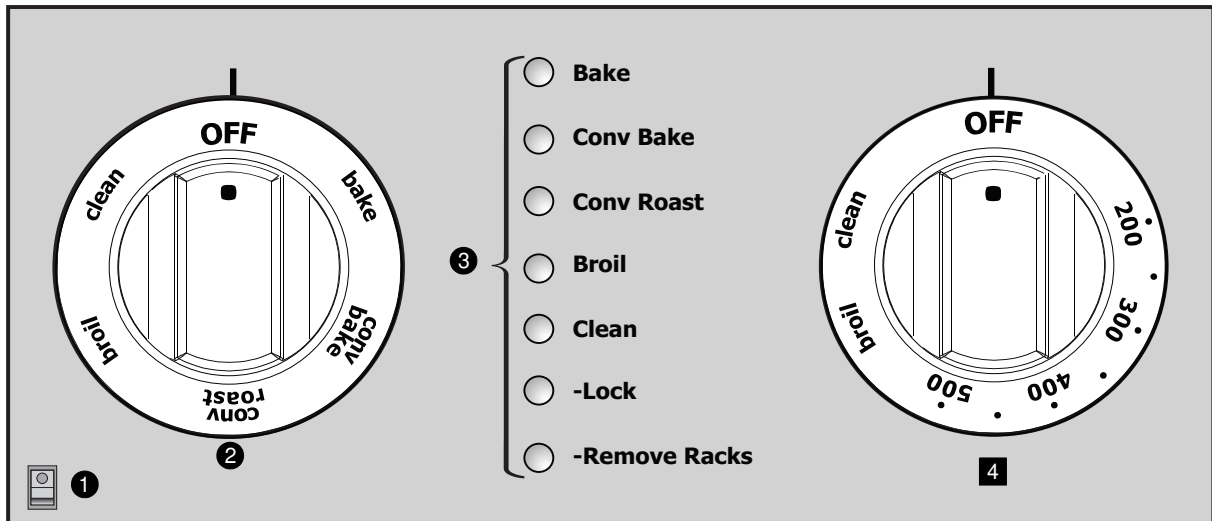

- Oven Light Switch** - On the left side of the oven control panel; use to turn oven lights on or off while oven is in use.
- Function Dial**
 - Bake** - Use for regular baking at normal temperatures ([page 18](#)).
 - Convection bake** - Uses a convection fan for even browning of foods ([page 19](#)).
 - Convection roast** - Uses convection fan for roasting foods such as hams, turkey, and roasts ([page 22](#)).
 - Broil** - Use to broil meats and foods at a default temperature of 550°F (288°C, [page 20](#)).
 - Clean** - use to select fixed 3 hour self cleaning cycle ([page 24](#)).
- Indicator Lights**
 - Bake** - When illuminated, indicates bake function is in use.
 - Convection bake** - When illuminated, indicates convection bake function is in use.
 - Convection roast** - When illuminated, indicates convection roast is in use.
 - Broil** - When illuminated, indicates broil function is in use.
 - Clean** - When illuminated, indicates cleaning cycle in process.
 - Lock** - When illuminated, shows oven door is fully locked. When blinking, shows door either locking or unlocking for self clean.
 - Remove Racks** - Blinks to inform user to remove all racks prior to performing a self clean cycle.
- Temperature Adjust Dial** - Use to select from a temperature range of 170°F to 500°F (77°C to 260°C).

Oven Minimum and Maximum Control Settings

| Feature | Min. Temp | Max. Temp |
|------------------|---------------|---------------|
| Bake | 170°F (77°C) | 500°F (260°C) |
| Convection Bake | 170°F (77°C) | 500°F (260°C) |
| Convection Roast | 170°F (77°C) | 500°F (260°C) |
| Broil | 550°F (288°C) | |
| Clean | 3 Hours | |

Getting Started

When the unit is first plugged in, or when the power supply to the range has been interrupted, the indicator lights will flash and the control will beep. To stop the lights from flashing, turn the selector control knob to **bake** and back to **OFF**.

Oven Lights

Your appliance includes theater style oven lighting that gradually lights the oven interior to full brightness. The oven is equipped with 2 halogen lights that turn on automatically when the oven door is opened. The interior oven lights are located on either side of the oven cavity. Each is covered with a glass shield that must be in place whenever the oven is in use.

Do not leave oven lights on while baking.

You can turn the oven lights on by using the oven light switch located on the left side of the control panel. The oven lights will not operate during a self clean cycle.

To change the interior light, see "[Caring for your glide racks](#)" on [page 31](#).

Bake

Use the bake function to cook food items with normal cooking temperatures. The convection fan will rotate when Bake is preheating. This is normal. The fan will turn off when the oven reaches the set temperature and the control will chime once to indicate the oven is ready. While baking, the oven will continue to cycle on and off to maintain the preset temperature.

IMPORTANT! For batter and dough-based baked goods such as cakes, pastries, and breads, use the convection bake function for best results.

For best results:

- Leave oven light off while baking.
- When using a single rack for baking, use position 4 Glide rack or 5 flat rack.
- For best results when baking cakes and cookies using 2 racks use convection bake.
- For cakes and cookies place cookware on oven rack positions 6 Glide rack (or 7 using flat rack) and position 2 Glide rack (or 3 using flat rack) as show in (Figure 13)
- Allow at least 2 inches (5 cm) space between the food items to ensure proper circulation. (Figure 14)
- Dark or dull pans and glass absorb more heat than shiny bakeware resulting in dark or over browning of foods. To prevent this it may be necessary to reduce the oven temperature or cook time to prevent over browning of some foods. Shiny pans are recommended for cakes, cookies and muffins.
- Do not open the oven door too often. Opening the door will reduce the temperature in the oven.

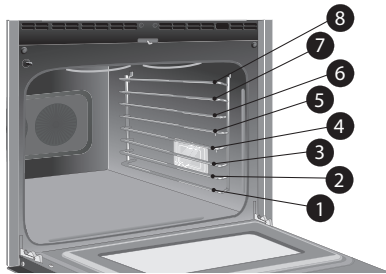

Figure 13: Rack positions

⚠ WARNING

Do not cook foods directly on the oven bottom. To avoid damaging the oven interior and surfaces, always cook foods in the oven using cookware positioned on an oven rack.

⚠ CAUTION

Always use pot holders or oven mitts when working with a hot oven. When cooking, the oven interior, oven racks and cooktop will become hot enough to cause burns.

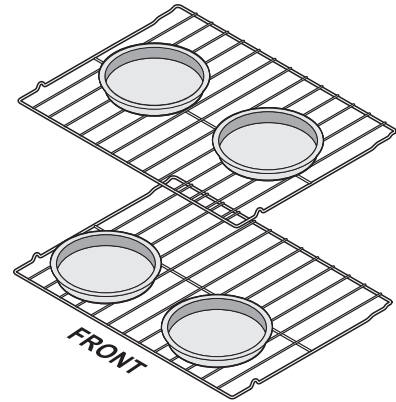

Figure 14: Suggested Pan Spacing for cakes

IMPORTANT! The oven **Bake** light will blink and the oven will not turn on if the temperature dial is set higher than 500°F (260°C).

To set the oven for bake at 350°F (177°C):

1. Arrange the oven racks as desired before preheating.
2. Turn the function dial to **bake**. The Bake indicator light will flash (Figure 15).

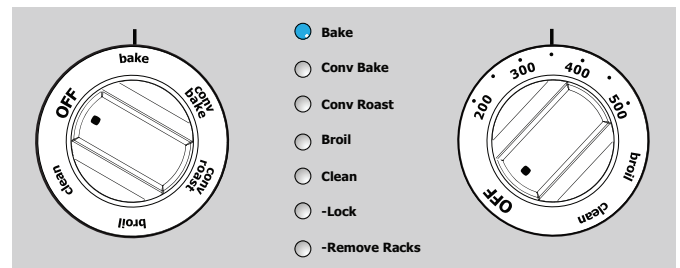

Figure 15: Selecting the bake function

3. Turn the temperature control knob to **350**. The Bake indicator light will remain on but stop flashing. The oven will begin to preheat.
4. When the set temperature is reached the oven control will chime.
5. Place the food in the oven and close the door.
6. When baking is completed or to cancel Bake at any time, turn the temperature and the function selector control knobs to **OFF**.

Convection Bake

Convection bake uses a fan to circulate the oven heat throughout the oven cavity (Figure 16). The improved heat distribution allows for even cooking results.

Benefits of convection bake:

- Multiple oven rack baking.
- Foods cook more evenly.

For best results:

- Leave oven light off while baking.
- When using a single rack, use glide rack in position 4 or the flat rack in position 5.
- When using two racks for layer cakes, use glide rack in rack positions 5 (or flat rack in position 6) and glide rack in position 1 (or flat rack in position 2) (Figure 16) and position cookware as shown in Figure 17.
- Allow at least 2 inches (5 cm) space between bakeware for proper air circulation.
- When using two racks to bake cookies and biscuits, place cookware on glide rack in position 1 (or flat rack in position 2) and the other glide rack in position 4 (or flat rack in position 5).
- Bake foods such as cookies and biscuits on pans with no sides or very low sides to allow heated air to circulate around the food. Food items baked on pans with a dark finish will cook faster.
- If using standard recipe, reduce temperature by 25° when using convection bake.
- Dark or dull pans and glass absorb more heat than shiny bakeware resulting in dark or over browning of foods. To prevent this it may be necessary to reduce the oven temperature or cook time to prevent over browning of some foods. Shiny pans are recommended for cakes, cookies and muffins.
- Do not open the oven door often. Doing so will reduce the oven temperature and may increase cook time.
- Use the convection bake feature for layer cakes

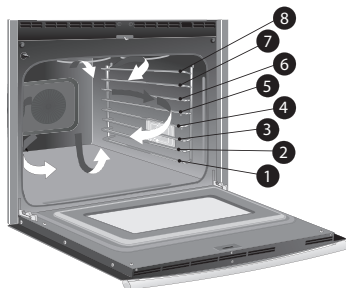

Figure 16: Rack positions and convection air flow

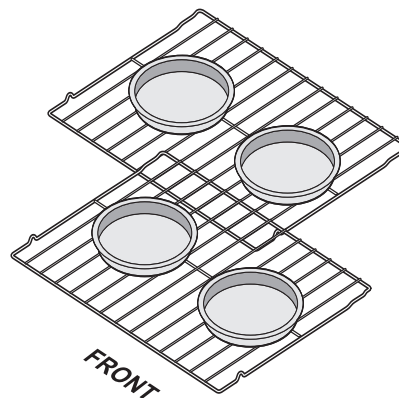

Figure 17: Suggested pan spacing

IMPORTANT! The oven Conv Bake light will blink and the oven will not turn on if the temperature dial is set higher than 500°F (260°C). The oven control has been factory set to reduce oven temperature for optimum convection bake performance.

To set the oven for convection bake at 350°F (177°C):

1. Arrange the oven racks as desired before preheating.
2. Turn the function dial to **conv bake**. The Conv Bake indicator light will flash (Figure 18).

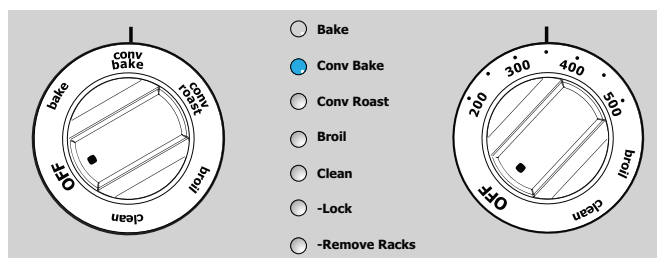

Figure 18: Convection bake selection

3. Turn the temperature control knob to the **350**. The **Conv Bake** indicator light will remain on but stop flashing. The oven will begin to preheat. The convection fan will turn on and remain on during the cooking process.
4. When the set temperature is reached the oven control will chime.
5. Place the food in the oven and close the door.
6. When baking is completed or to cancel Conv Bake at any time, turn the temperature and the function selector control knobs to **OFF**.

Broil

Use the broil feature to cook meats requiring direct exposure to radiant heat for optimum browning results. Broil foods with the oven door closed.

⚠ WARNING

If an oven fire occurs, turn the oven off and do not open the door. Opening the door will feed oxygen to the fire. If the fire continues, you can throw baking soda on the fire or use a Class B/C fire extinguisher. Do not put water or flour on the fire. Flour can be explosive and water can cause a grease fire to spread possibly causing personal injury.

⚠ CAUTION

Always use pot holders or oven mitts when working with a hot oven. When broiling, the oven interior, oven racks and cooktop will become hot enough to cause burns. Do not use the broiler pan without the insert. Do not cover the broil pan or insert with aluminum foil; the exposed grease could ignite.

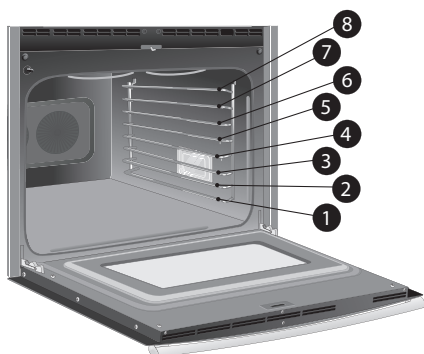

Figure 19: Rack positions

⚠ CAUTION

To prevent food from contacting the broil element place on appropriate rack position to avoid grease splattering, and use the broil pan and insert when broiling.

Do not use the broiler pan without the insert. Do not cover the broiler insert with foil. The exposed grease could ignite. The insert is slotted and allows the grease to drain away from the meat and the high heat of the broiler into the broiler pan (Figure 20).

To set Broil:

1. Place broiler pan insert on the broiler pan. Then place the food on the broiler pan insert. Do not use the broiler pan without the insert.
2. Arrange the interior oven rack and place the broiler pan on the rack. Be sure to center the broiler pan directly under the broiler element. If preheating the broil element, position the broiler pan with food after step 4.
3. Turn the Selector knob to **broil**. The corresponding indicator light will flash.
4. Turn the Temperature knob to **broil**. The indicator light will remain on until the Selector or Temperature knob is turned **OFF**. Broil with oven door closed.

Broil Auto Shut Off: If oven door is open for more than one minute during Broil and the oven temperature is above 350°F, the control will beep. If door is not closed it will turn off Broil element after another 30 seconds.

5. Turn the temperature and the selector control knobs to **OFF** when cooking is completed or to cancel broil.

For best results:

- For optimum browning results, fully preheat for 2 minutes before placing meat in the oven. To avoid burning food, watch the food carefully when broiling and turn meat when needed. Broil with the oven door closed.
- Refer to Table 3 for the type and amount of meat being prepared.

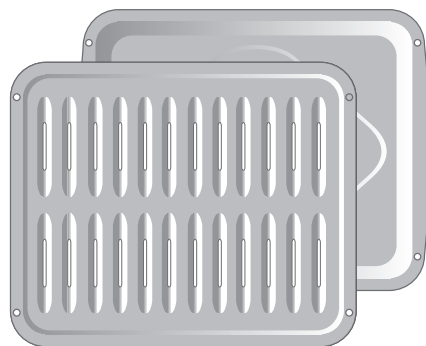

Figure 20: Broil pan and insert

Recommended Broiling Times

Use the broiling table (Table 2 below) for recommended broiling times for the types of meat listed.

Depending on the desired doneness of meat, increase or decrease broiling times or adjust broiling pan to different rack positions. If the food you are broiling is not listed in the table, follow the instructions provided in your recipe and watch the broiling process closely.

IMPORTANT! Broil Auto Shut Off: If oven door is open for more than one minute during Broil and the oven temperature is above 350°F, the control will beep. If door is not closed it will turn off Broil element after another 30 seconds.

Table 2: Broiling Recommendations

| Food | Rack Position | Temperature | Cook time (minutes) | | Internal Temperature | Doneness |
|-----------------------|---------------|---------------|---------------------|----------|----------------------|-------------|
| | | | 1st side | 2nd side | | |
| Steak 1" thick | 7th* | 550°F (288°C) | 5 | 5 | 140°F (60°C) | Rare** |
| Steak 1" thick | 7th* | 550°F (288°C) | 8 | 6 | 145°F (63°C) | Medium |
| Steak 1" thick | 7th* | 550°F (288°C) | 9 | 7 | 160°F (71°C) | Medium-well |
| Steak 1" thick | 7th* | 550°F (288°C) | 10 | 9 | 170°F (77°C) | Well |
| Pork Chops 3/4" thick | 6th* | 550°F (288°C) | 18 | 10 | 170°F (77°C) | Well |
| Chicken bone-in | 6th | 550°F (288°C) | 22 | 12 | 170°F (77°C) | Well |
| Chicken boneless | 6th | 550°F (288°C) | 14 | 10 | 170°F (77°C) | Well |
| Fish | 7th | 550°F (288°C) | 15 | n/a | 170°F (77°C) | Well |
| Shrimp | 7th | 550°F (288°C) | 7 | n/a | 170°F (77°C) | Well |
| Hamburger 1" thick | 8th | 550°F (288°C) | 11 | 9 | 145°F (63°C) | Medium |
| Hamburger 1" thick | 8th | 550°F (288°C) | 12 | 10 | 170°F (77°C) | Well |

* Rack position 7 is for broiling using flat rack. Use one position lower when using the glide rack.

** The U.S. Department of Agriculture states, "Rare fresh beef is popular, but you should know that cooking it to only 140°F (60°C) means some food poisoning organisms may survive." (Source: Safe Food Book, Your Kitchen Guide, USDA) The lowest temperature recommended by the USDA is 145°F (63°C) for medium rare fresh beef. For well done 170°F (77°C). Broiling is direct heat cooking and will produce some smoke. If smoke is excessive, place food further away from element. Always watch foods carefully to prevent burning.

Convection Roast

Convection roast combines a cook cycle with the convection fan and element to roast meats and poultry. Heated air circulates around the meat from all sides, sealing in juices and flavors.

Meats cooked with this feature are crispy and brown on the outside while staying moist inside. Preheating for convection roast will not be necessary for most meats and poultry.

See [Table 3, "Convection roasting temperature and time recommendations,"](#)

⚠ WARNING

If an oven fire occurs, turn the oven off and do not open the door. Opening the door will feed oxygen to the fire. If the fire continues, you can throw baking soda on the fire or use a Class B/C fire extinguisher. Do not put water or flour on the fire. Flour can be explosive and water can cause a grease fire to spread possibly causing personal injury.

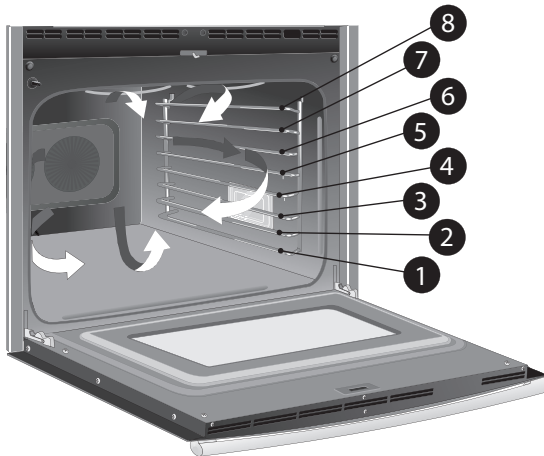

IMPORTANT! The oven **Conv Roast** light will blink and the oven will not turn on if the temperature dial is set higher than 500°F (260°C).

To use convection roast at a temperature of 350°F (177°C):

1. Place oven rack on the bottom or next to the bottom oven rack position.
2. Place the meat on the broiler pan and insert.
3. Make sure the insert is securely seated on top of the broiler pan. Do not use the broiler pan without the insert.
4. Place meat (fat side up) on insert.
5. Place prepared food on oven rack and slide into oven.
6. Close the door.
7. Turn the function dial to **conv roast**. The Conv Roast indicator light will flash ([Figure 21](#))
8. Turn the temperature control knob to **350**. The **Conv Roast** indicator light will remain on but stop flashing. The oven will begin preheat.
9. When cooking is completed or to cancel convection roast turn the temperature and the selector control knobs to **OFF**.

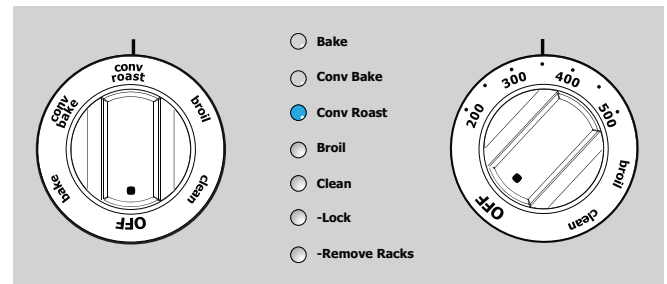

Figure 21: Convection roast selection

Convection Roasting tips:

- Preheating for convection roast is not necessary.
- Roast food on the lowest rack of the oven.
- When cooking meats use the broiler pan and insert. The broiler pan will catch grease spills and the insert helps prevent grease splatters.
- Convection roast cooks faster, you can reduce cook times as much as 25% from the recommended recipe. If needed, increase cook time until the desired doneness is obtained.
- Carefully follow your recipe's temperature and time recommendations or refer to the convection roast recommendations for additional information.
- Do not cover foods when dry roasting - covering will prevent the meat from browning properly.

Table 3: Convection roasting temperature and time recommendations

| Meat | | Weight | Oven Temp | Internal Temp | Minutess per lb. |
|-------------|----------------------|---------------|----------------------------|----------------------|-------------------------|
| Beef | Standing rib roast* | 4 to 6 lb. | 350°F (177°C) | *160°F (71°C) | 25-30 |
| | Rib eye roast* | 4 to 6 lb. | 350°F (177°C) | *160°F (71°C) | 25-30 |
| | Tenderloin roast | 2 to 3 lb. | 400°F (204°C) | *160°F (71°C) | 15-25 |
| Poultry | Turkey whole** | 12 to 16 lb. | 325°F (163°C) | 180°F (82°C) | 8-10 |
| | Turkey whole** | 16 to 20 lb | 325°F (163°C) | 180°F (82°C) | 10-15 |
| | Turkey whole** | 20 to 24 lb. | 325°F (163°C) | 180°F (82°C) | 12-16 |
| | Chicken | 3 to 4 lb. | 350°F-375°F (177°C-191°C)* | 180°F (82°C) | 12-16 |
| Pork | Ham roast, fresh | 4 to 6 lb. | 325°F (163°C) | 160°F (71°C) | 30-40 |
| | Shoulder blade roast | 4 to 6 lb. | 325°F (163°C) | 160°F (71°C) | 20-30 |
| | Loin | 3 to 4 lb. | 325°F (163°C) | 160°F (71°C) | 20-25 |
| | Pre-cooked ham | 5 to 7 lb. | 325°F (163°C) | 160°F (71°C) | 30-40 |

* The U.S. Department of Agriculture states, "Rare fresh beef is popular, but you should know that cooking it to only 140°F (60°C) means some food poisoning organisms may survive." (Source: Safe Food Book, Your Kitchen Guide, USDA Rev. June 1985.) The lowest temperature recommended by the USDA is 145°F (63°C) for medium rare fresh beef. For well done 170°F (77°C) ** Stuffed turkey requires additional roasting time. Shield legs and breast with foil to prevent over browning and drying of the skin.

Cleaning the Oven

⚠ WARNING

All oven racks, rack ladders, and accessories must be removed from the oven interior when the oven is cool prior to self clean to avoid possible damage. If the oven racks are not removed they may discolor and become difficult to slide.

⚠ CAUTION

The Luxury Glide™ oven rack must be removed when the oven is cool before starting self clean to avoid damaging the glide ability of the rack. The **Clean** and **Remove Racks** indicator lights will flash as a reminder to remove the racks before starting a self clean cycle. Refer to “Oven Racks” on page 14 for instructions for removing and replacing all racks.

⚠ CAUTION

Do not force the oven door open when self clean is active. This can damage the automatic door-locking system. The door will not unlock until the oven has sufficiently cooled. Use caution when opening the door after self clean cycle is complete; the oven may still be very hot.

⚠ WARNING

Do not touch the oven during the self clean cycle. Keep children away from the oven during the self clean cycle. Failure to follow these instructions can result in burns.

⚠ CAUTION

The health of some birds is extremely sensitive to the fumes given off during the self clean cycle of any range. Move birds to another well-ventilated room.

⚠ CAUTION

Do not line the oven walls, oven racks, oven bottom or any other part of the range with aluminum foil. Doing so will stop heat distribution, produce poor baking results and may cause permanent damage to the oven interior. Aluminum foil will melt to a hot oven surface during self clean. Do not spray oven cleaners or protective coatings in or around any part of the oven interior.

⚠ CAUTION

The oven may appear to have cooled off after use. The elements may still be hot and burns may occur if the oven surface is touched before sufficiently cooling.

A self cleaning oven automatically cleans itself by using much higher temperatures than those used for cooking. The self clean feature eliminates soils completely or reduces them to a fine powdered ash that, when the oven has cooled, can be wiped away easily with a damp cloth.

The self clean function provides a default 3 hour clean time setting for self cleaning.

When the oven is set to run a self-clean cycle, the motor door lock will begin locking the oven door. Do not open the oven door while the lock motor is running or when any locking indicators or displays are showing. The oven door is completely locked in about 15 seconds.

IMPORTANT! Read and adhere to the following precautions before starting self clean:

- Completely remove all items from the oven and cooktop including food, cookware, utensils, plastic, all racks, and any aluminum foil. Aluminum foil will not withstand high temperatures generated during the self clean cycle.
- Do not leave small children unattended near the appliance. During self clean, the range will become very hot to the touch.
- Be sure the oven vent is clear.
- Be sure oven light shield is in place.
- Remove any excess spills or loose debris. Spills on the oven bottom should be wiped up and removed before starting self clean. To clean, use hot, soapy water and a cloth. Large food spill overs can cause heavy smoke or a fire during self clean. Spills that have a high sugar or acid content (such as milk, tomatoes, sauerkraut, fruit juices or pie filling) may leave a dull spot even after self cleaning.
- Do not clean the oven door gasket (Figure 22). Do not use any cleaning materials on the oven door gasket. Doing so may damage the gasket. The woven material of the oven door is essential for a good seal. Care should be taken not to rub, damage or remove the door gasket.

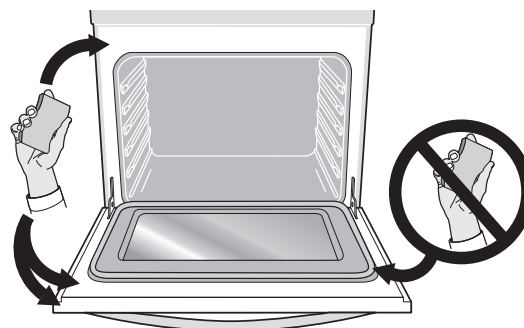

Figure 22: Areas of oven door to clean with caution

- Do not use commercial oven cleaners or protective coatings of any kind inside oven. Residue from oven cleaners may damage the porcelain during the next self clean cycle.
- Clean any soil from the oven exterior. Clean using soap and water before starting a self clean cycle. If soils are not removed, they may burn on due to the high temperature during self clean.

To start a clean cycle:**⚠ WARNING**

All oven racks, rack ladders, and accessories must be removed from the oven interior to avoid possible damage. If the oven racks are not removed they may discolor.

⚠ CAUTION

The Luxury Glide™ oven rack must be removed before starting self clean to avoid damaging the glide ability of the rack. The **Clean** and **Remove Racks** indicator lights will flash as a reminder to remove the racks before starting a self clean cycle. Refer to “Oven Racks” on page 14 for instructions for removing and replacing all racks.

1. Turn the function dial to **clean**. The **Clean** and **Remove Racks** indicator lights will blink to remind you to remove the racks and rack ladders from the oven cavity (Figure 23).

⚠ WARNING

Remove all oven racks, rack ladders, and accessories from the oven interior to avoid possible damage. If the oven racks are not removed they may discolor.

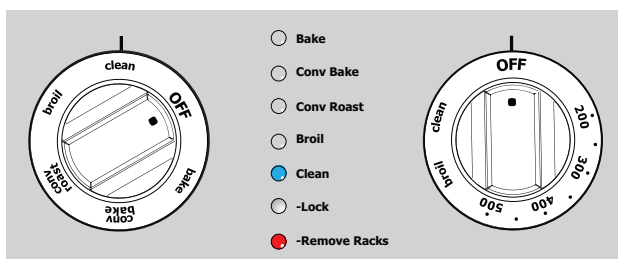
**Figure 23: Initial clean selection**

2. Turn the temperature adjust dial to **clean**. The **Clean** indicator light will be steady and the **Lock** indicator light will blink while the door lock engages (about 15 seconds). Refer to Figure 24 below.

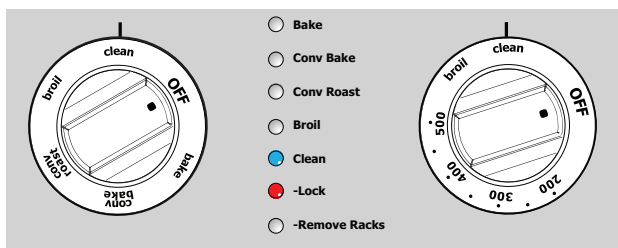
**Figure 24: Clean cycle initiated**

Once the door lock is fully engaged the **Lock** light will illuminate continuously and the oven will begin a default 3 hour clean cycle. During this time the convection fan is off for the duration of the clean cycle.

3. To cancel self clean, turn both control knobs to **OFF**. Allow enough time for the oven to cool and for the door to unlock before the door may be opened.

To start clean after cancelling:

If self clean was cancelled shortly after being started, and the oven interior did not reach high self clean temperatures, the next clean cycle may be set as soon as the oven door unlocks from the cancelled clean cycle. If the oven reached high temperatures before the self clean cycle was cancelled, you may be required to wait up to 4 hours before the control will allow another self clean cycle to be started.

To restart a clean cycle after a power outage:

If the self clean cycle was interrupted by a power failure, the oven may not be thoroughly cleaned. Another self clean cycle may be needed. Once power is restored, the oven has cooled and the door unlocks, set to clean for another cycle.

⚠ CAUTION

To avoid possible burns use caution when opening the oven door after the self clean cycle has finished. The oven may still be very hot. Stand to the side of the oven when opening the door to allow hot air to escape.

⚠ CAUTION

Do not force the oven door open when self clean is active. This can damage the automatic door-locking system. The door will not unlock until the oven has sufficiently cooled. Use caution when opening the door after self clean cycle is complete; the oven may still be very hot.

When Self Clean is finished:**⚠ CAUTION**

The oven may appear to have cooled after it has been turned off. It may still be hot and burns may occur if the oven walls are touched before they have cooled.

1. The Clean light will turn off and -Lock will remain lit while the oven is still hot.
2. Once the oven has cooled (about 1 hour) the -Lock light will go out.

⚠ CAUTION

Attempting to force open the oven door before the light is out can damage the motor door latch.

3. When the oven interior has completely cooled, wipe away any residue or powdered ash with a damp cloth or paper towel.

IMPORTANT!

- The kitchen area should be well ventilated. Use an open window, ventilation fan or exhaust hood during the first self clean cycle to help eliminate the normal odors associated the initial clean cycle.
- When self clean finishes the oven door will remain locked until the oven has cooled sufficiently. Allow about 1 hour for the oven to cool before opening the oven door.

CARE AND CLEANING

Cleaning Various Parts of Your Oven

Before cleaning any part of the oven, ensure all controls are turned off and the oven is cool. Remove spills and any heavy soiling as soon as possible.

| Surface Type | Recommendation |
|---|---|
| Control knobs Painted body parts Painted decorative trims Aluminum, plastic, or vinyl trim | Use a soft cloth and clean with mild dish detergent and water or a 50/50 solution of vinegar and water. Follow by rinsing the area with clean water; dry and polish with a soft cloth. Glass cleaners may be used if sprayed on a soft cloth first. Do not spray liquids directly on the oven control and display area. Do not use large amounts of water on the control panel. Excess water on the control area may cause damage to the appliance. Do not use other liquid cleaners, abrasive cleaners, scouring pads, or paper towels. They will damage the finish. |
| Control panel Decorative trim) | Use a soft cloth and clean with mild dish detergent and water or a 50/50 solution of vinegar and water. Follow by rinsing the area with clean water; dry and polish with a soft cloth. Glass cleaners may be used if sprayed on a soft cloth first. Do not spray liquids directly on the oven control and display area. Do not use large amounts of water on the control panel. Excess water on the control area may cause damage to the appliance. Do not use other liquid cleaners, abrasive cleaners, scouring pads, or paper towels. They will damage the finish. |
| Stainless Steel | Only use cleaners and polishes specifically manufactured for cleaning stainless steel. Always rub in direction of metal grain to avoid damaging. Do not use cleaners with high concentrations of chlorides or chlorine. Do not use harsh scrubbing cleaners. Polish with a lint-free cloth. Be sure to wipe excess cleaner/polish off from the metal surface as bluish stains may occur during future oven heating that cannot be removed. Clean heavier soils with hot, soapy water and a cloth or sponge. Use clean water to rinse; use a cloth to dry. |
| Porcelain enamel parts Porcelain enamel broiler pan inserts Door liner and body parts | Gentle scouring with a soapy scouring pad will remove most spots. Rinse with a 1:1 solution of clear water and ammonia. If necessary, cover difficult spots with an ammonia-soaked paper towel for 30 to 40 minutes. Rinse with clean water and a damp cloth, and then scrub with a soap-filled scouring pad. Rinse and wipe dry with a clean cloth. Remove all cleaners or the porcelain may become damaged during future heating. |
| Oven interior | Remove oven racks from the oven cavity before cleaning the oven interior. Use a mild, abrasive cleaner following manufacturer's instructions. Rinse with clean water and dry. For very important cleaning precautions, read " Cleaning the Oven " on page 24 . |
| Luxury Glide racks | Remove from oven before starting self clean cycle. If racks become hard to slide refer to " Caring for your glide racks " on page 31 . |
| Oven racks | Oven racks and oven rack supports must be removed from oven cavity during the self clean cycle for cleaning. Clean by using a mild, abrasive cleaner following manufacturer's instructions. Rinse with clean water and dry. |
| Oven door | Use soap and water to thoroughly clean the top, sides, and front of the oven door. Rinse well. You may use a glass cleaner on the outside door glass. Do not immerse the door in water. Do not spray or allow water or the glass cleaner to enter the door vents. Do not use oven cleaners, cleaning powders, or any harsh abrasive cleaning materials on the outside of the oven door. The oven gasket is essential for a good seal. It is located on the inner frame of the door and visible when the door is opened. Do not clean the oven door gasket. On self clean models, the oven door gasket is made of a woven material. Care should be taken not to rub, damage, or remove this gasket. |
| Oven door window (interior) | Use a small amount of ceramic glass cleaner to remove residue on oven glass. Wipe off with paper towel after cleaning. |
| Cooktop surface, burners and burner grates | Do not use spray oven cleaners on the cooktop. " Cleaning the Sealed Burners " instructions on page 28 . |

General Cleaning

Refer to the table at the beginning of this chapter for more detailed information about cleaning specific parts of the range.

⚠ CAUTION

Before manually cleaning any part of the range, be sure all controls are turned off and the range is cool. The range may be hot and can cause burns.

⚠ CAUTION

Ammonia must be rinsed before operating the oven. Provide adequate ventilation.



Figure 25: Cleaning agents to avoid

Aluminum Foil, Aluminum Utensils, and Oven Liners

⚠ WARNING

Never cover any slots, holes, or passages in the oven bottom or cover an entire oven rack with materials such as aluminum foil. Doing so blocks air flow through the oven and may cause carbon monoxide poisoning. Aluminum foil linings may trap heat, causing a fire hazard.

⚠ WARNING

Protective liners—Do not use aluminum foil to line the oven bottom. The high heat of the oven can melt these materials to the oven cavity and ruin the oven. These types of materials can also reduce the effectiveness of the air circulation in the oven and produce poor baking results. Only use aluminum foil as recommended in this manual. Improper installation of these liners may result in risk of electric shock or fire.

- **Aluminum foil** - Use of aluminum foil on a hot cooktop can damage the cooktop. Do not use thin aluminum cooking utensils or allow aluminum foil to touch the surface burners under any circumstances.
- **Aluminum utensils** - The melting point of aluminum is much lower than that of other metals. If aluminum pans are allowed to boil dry when using the cooktop, the utensil will be damaged or destroyed.
- **Oven racks** - Do not use aluminum foil to cover the oven racks. During self clean the oven temperature can become hot enough to melt aluminum cooking utensils or aluminum foil and could result in permanent damage to the oven interior and porcelain finish.

Cleaning the Glass Cooktop

⚠ CAUTION

To avoid possible burns do not attempt any of the cleaning instructions provided below before turning off all surface burners and allow them to cool.

Your cooktop is glass with gas sealed burners. To clean the glass portion of the cooktop follow these directions.

For light to moderate soil:

Apply a few drops of cooktop cleaning cream directly to the glass part of the cooktop. Use a clean paper towel to clean the entire cooktop surface. Make sure the cooktop is cleaned thoroughly, leaving no residue. Do not use the towel you use to clean the cooktop for any other purpose.

For heavy, burned on soil:

Apply a few drops of cooktop cleaning cream directly to the soiled area. Rub the soiled area using a non-abrasive cleaning tool, applying pressure as needed. Do not use the pad you use to clean the cooktop for any other purpose. If soils remain, carefully scrape soils with a metal razor blade scraper, holding scraper at a 30 degree angle to the surface (Figure 26). Remove loosened soils with cooktop cleaning cream and buff surface clean.

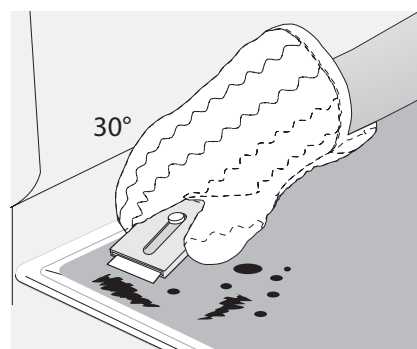

Figure 26: Use razor to scrape sediment on glass surface

Cleaning the Sealed Burners

⚠ CAUTION

To avoid possible burns do not attempt any of the cleaning instructions provided below before turning off all surface burners and allow them to cool.

- To avoid possible burns use care when cleaning the cooktop. do not attempt to clean the cooktop whenever the cooktop or burner heads are still hot.
- To avoid possible burns do not attempt any of the following cleaning instructions provided before turning OFF all of the surface burners and allow them to cool.
- To avoid possible burns do not attempt to operate the surface burners without the burner caps.

⚠ CAUTION

Any additions, changes or conversions required in order for this appliance to satisfactorily meet the application needs must be made by an authorized qualified Agency.

Routinely clean the cooktop. Wipe with a clean, damp cloth and wipe dry to avoid scratches. Keeping the surface burner head ports and slots clean will prevent improper ignition and an uneven flame. See the following sections for more instructions.

To clean recessed and contoured areas of cooktop:

- If a spill occurs on or in the recessed or contoured areas, blot up spill with an absorbent cloth.
- Rinse with a clean, damp cloth and wipe dry.

To clean burner caps:

- Remove caps from burner heads after they have cooled. Do not clean burner caps in the dishwasher. Thoroughly dry burner caps immediately following cleaning including the bottom and inside of cap. Do not operate surface burners without burner caps properly in place.
- Lift the burner cap from the burner head. The surface burner heads are secured to the cooktop and **must be cleaned in place**. For proper gas flow it may be necessary to clean the burner heads and slots.
- Clean heavy soils with a plastic scrubbing pad and absorbent cloth. Do not use abrasive cleaners. They can scratch porcelain.

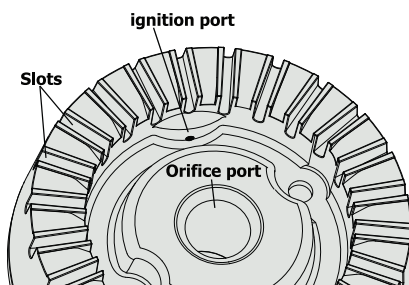

Figure 27: Sealed burner components

Cleaning the G5 Burner Head Ignition Port

Each G5 burner head has a small ignition port as shown in the illustration below (Figure 28).

Should you experience ignition problems it may be this port is partially blocked. Use a small wire gauge needle, toothpick, or the end of a paper clip to clear the ignition port.

IMPORTANT! Always keep the surface burner caps in place whenever a surface burner is in use.

When replacing the burner caps, be sure the burner caps are seated firmly on top of the burner heads. The surface burner heads are secured to the cooktop and must be cleaned in place on the cooktop for proper flow of gas and ignition of burners.

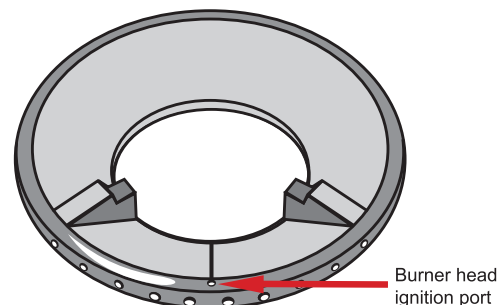

Figure 28: G5 ignition port

Do not allow spills, food, cleaning agents or any other material to enter the gas orifice holder opening.

Cleaning G5 Burner Heads

Burner cap

The lid on the inside of the double ring is designed to fit loosely. Clean with normal non abrasive glass type cleaner and thoroughly dry before replacing. See Figure 29 below.

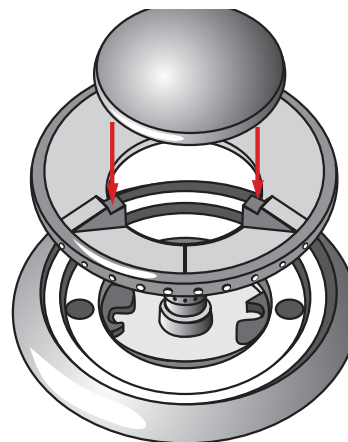

Figure 29: Burner cap placement

To clean the G5 surface burner head and ports:

1. Lift the burner cap from the burner head to clean the burner head and ports (See [Figure 30](#)).

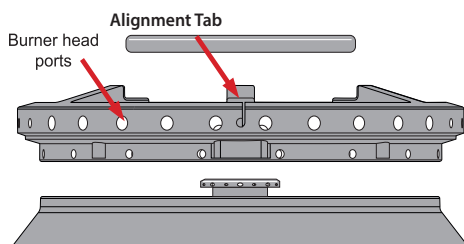

Figure 30: Burner head ports

2. Lift and remove the head from the surface burner plates.
3. Use a clean damp cloth to soak up any spills.
4. Remove any food from between the burner slots using a small nonabrasive brush like a toothbrush.
5. Wipe up using a damp cloth afterwards.
6. For stubborn soils located in the slots, use a small-gauge wire, toothpick, or needle to clean.
7. Be sure to replace all burner parts correctly as shown in “[Burner Caps and Burner Grates Assembly](#)” on [page 9](#).

IMPORTANT! Any spill on or around the electrode must be carefully cleaned. Take care not to hit the electrode with anything hard or it could be damaged.

Should you experience ignition problems it may be that an ignition port hole is partially blocked with soil (see both figures). With the burner head in place, use a small wire gauge needle or the end of a paper clip to clear the ignition port or ports.

Broiler Pan Cleaning Tips

CAUTION

Protective liners--Do not use aluminum foil to line the oven bottom. Improper installation may result in a risk of electrical shock or fire.

To make cleaning easier, the bottom of the broiler pan may be lined with aluminum foil. Do not cover the broiler insert with foil.

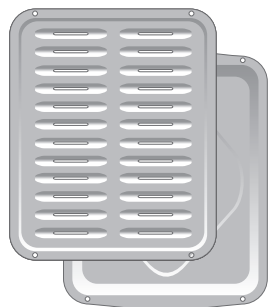

Figure 31: Broil pan and insert

To prevent grease from baking on, remove the broiler pan from the oven as soon as cooking is completed. Use potholders or oven mitts because the broiler pan is extremely hot. Pour off grease. Soak the pan in hot, soapy water. Clean the broiler pan and insert as soon as possible after each use. If necessary, use soap-filled steel wool pads. Heavy scouring may scratch the insert.

To clean burner grates:

- Clean when the grates are cool. Use nonabrasive plastic scrubbing pad and mild abrasive cleanser.
- Food soils containing acids may affect the finish. Clean immediately after the grates are cool. Thoroughly dry grates immediately following cleaning.

Replacing Oven Lights

Your oven is equipped with interior oven lights that ramp up gradually when the oven door is opened. The oven lights can also be turned on when the door is closed by using the oven light switch located on the control panel.

To remove and replace a light bulb:

CAUTION

Be sure the range is unplugged and all parts are cool before replacing oven light. Wear a leather-faced glove for protection against possible broken glass. Do not allow your fingers to touch the new bulb when replacing. Use a clean soft cloth or paper towel to cover the new bulb when installing.

1. Turn electrical power off at the main source or unplug the appliance.
2. To remove the glass shield, pull the back side of the shield toward the inside of the oven in a manner to lift it up from the oven side. The glass shield should come out easily by pushing a little toward front of the wall oven ([Figure 32](#)).
3. Replace the halogen appliance bulb.
4. Gently push the glass shield toward the oven wall until it is firmly seated against the oven wall.
5. Reconnect electrical power to the appliance or turn power back on.

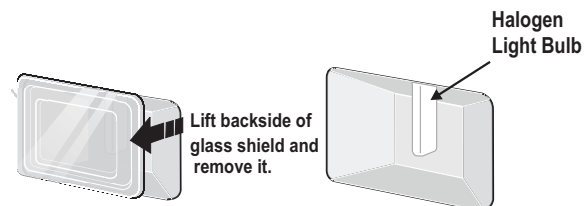

Figure 32: Light shield and bulb

Removing and Replacing the Oven Door

⚠ CAUTION

The door is very heavy. For safe, temporary storage, lay the door flat with the inside of the door facing down.

⚠ WARNING

To prevent possible burns, do not attempt to remove the oven door until the oven has completely cooled.

To remove the oven door:

1. Open oven door completely, horizontal with floor (Figure 33).
2. Pull up the lock located on each hinge support toward front of the oven. You may have to apply a little upward pressure on the lock to pull it up (Figure 34 and Figure 35).
3. Grasp the door by the sides, pull the bottom of the door up and toward you to disengage the hinge supports.

⚠ CAUTION

The door is very heavy. Use caution when lifting the door. Improper lifting can cause injury.

4. Keep pulling the bottom of the door toward you while rotating the top of the door toward the appliance to completely disengage the hinge levers (Figure 36).

To Replace Oven Door:

1. Firmly grasp both sides of oven door along the door sides. Do not use the oven door handle (Figure 36).
2. Holding the oven door at the same angle as the removal position, seat the hook of the hinge arm over the roller pins located on each side of the oven door frame (Figure 34 and Figure 35). The hook of the hinge arms must be fully seated onto the roller pins.
3. Fully open the oven door, horizontal with floor (Figure 33).
4. Push the door hinge locks up toward and into the oven frame on both left and right oven door hinges to the locked position (Figure 34).
5. Close the oven door.

IMPORTANT!

Special Door Care Instructions - Most oven doors contain glass that can break. Read the following recommendations:

- Do not close the oven door until all the oven racks are fully in place.
- Do not hit the glass with pots, pans, or any other object.
- Scratching, hitting, jarring, or stressing the glass may weaken its structure causing an increased risk of breakage at a later time.



Figure 33: Door removal

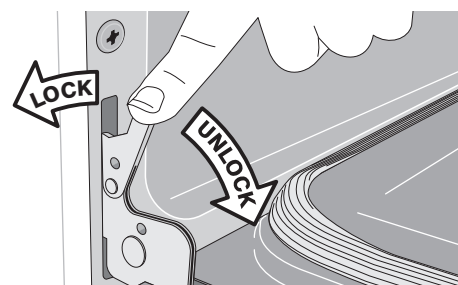

Figure 34: Unlocking hinge

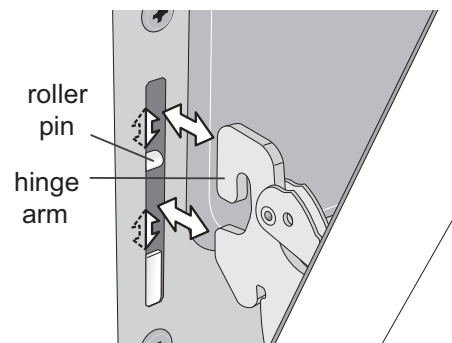

Figure 35: Lock disengaged for door removal

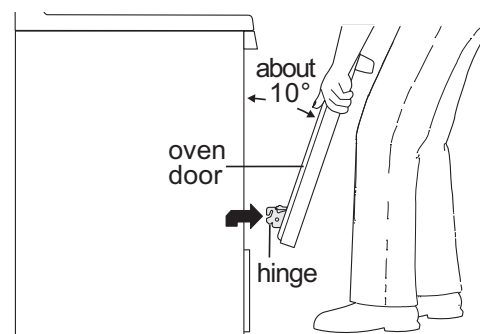

Figure 36: Hinge slot - door removed from appliance

Caring for your glide racks

⚠ CAUTION

Handle oven racks only when they are cool. After cooking racks will be very hot and can cause burns.

IMPORTANT! Remove all oven racks before starting a self clean cycle. If oven racks are left inside the oven during a cleaning cycle, the slide ability of the glide rack may be damaged and the racks will lose their finish.

- Anytime the gliding is rough, the glide rack tracks should be treated with graphite lubrication.
- Do not use cooking oil, cooking spray, or other oil-based lubrication products on the glide rack extension tracks. Use only the graphite lubrication in this area. To order graphite lubrication, contact your installer, servicer or dealer.

To lubricate the glide rack:

1. Remove the rack from the oven and place the rack on a large flat surface covered with newspaper or scrap cloth. Fully extend the rack.
2. Wipe away debris and crumbs from the glide track using a cloth or sponge.

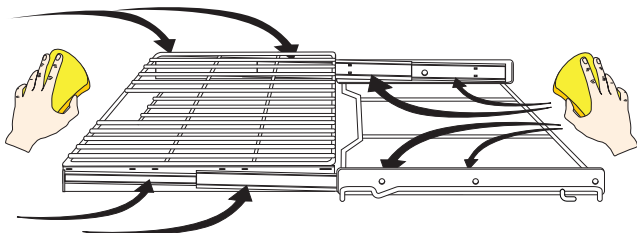

3. Shake graphite lubrication very well before applying. Place four drops of graphite lubrication along the tracks (see area circled on figure below). Repeat on both sides of the glide rack.

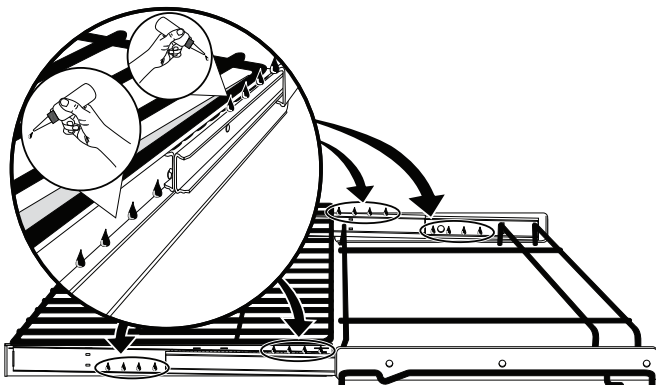

4. Extend and return the glide rack several times along the tracks to distribute the lubrication.

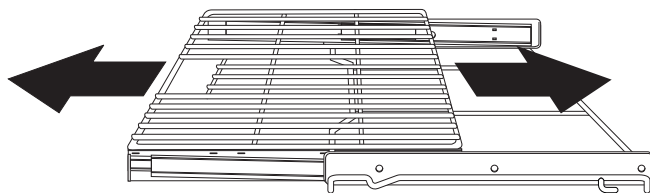

5. Turn glide rack over. Shake graphite lubrication very well before applying. Place four drops of graphite lubrication along the tracks. Repeat on both sides of the glide rack.

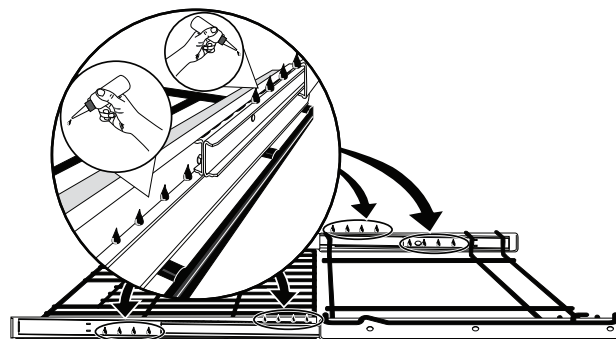

6. Extend and return the glide rack several times along the tracks to distribute the lubrication.

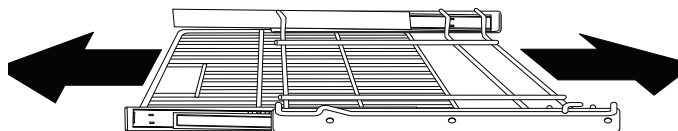

7. Apply a thin layer of cooking oil to the outer frame of the glide rack as shown below. Keeping the frame sides lightly lubricated allows the entire rack to slide easily when changing rack positions.

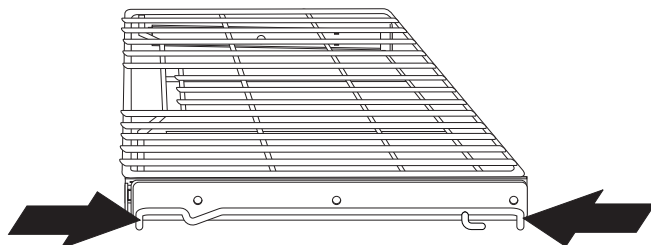

BEFORE YOU CALL





OVEN BAKING

Oven Baking

For best cooking results, heat the oven before baking cookies, breads, cakes, pies, or pastries, etc. There is no need to preheat the oven for roasting meat or baking casseroles.

The cooking times and temperatures needed to bake a product may vary slightly from your previously owned appliance.



Baking Problems and Solutions

| Baking Problems | Causes | Corrections |
|---|--|---|
| Cookies and biscuits burn on the bottom.  | <ul style="list-style-type: none"> • Cookies and biscuits put into oven before the preheating time is completed. • Oven rack is overcrowded or rack position too low. • Dark pans absorb heat too fast. | <ul style="list-style-type: none"> • Allow oven to preheat to desired temperature before placing food in oven. • Choose pan sizes that will permit 2 to 4 inches (5.1 cm to 10.2 cm) space on all sides when placed in the oven. • Use a medium weight baking sheet. |
| Cakes too dark on top or bottom  | <ul style="list-style-type: none"> • Cakes put in oven before preheating time is completed. • Rack position too high or too low. • Oven too hot. | <ul style="list-style-type: none"> • Allow oven to preheat to the selected temperature before placing food in the oven. • Use proper rack position for baking needs. • Set oven temperature 25°F (13°C) lower than recommended. |
| Cakes not done in center  | <ul style="list-style-type: none"> • Oven too hot. • Incorrect pan size. • Pan not centered in oven. | <ul style="list-style-type: none"> • Set oven temperature 25°F (13°C) lower than recommended. • Use pan size suggested in recipe. • Use proper rack position and place pan so there is 2 to 4 inches (5.1 cm to 10.2 cm) space on all sides of pan. |
| Cakes not level.  | <ul style="list-style-type: none"> • Oven not level. • Pan too close to oven wall or rack overcrowded. • Pan warped. • Oven light on while baking. | <ul style="list-style-type: none"> • Place a marked glass measuring cup filled with water on the center of the oven rack. If the water level is uneven, refer to the installation instructions for leveling the oven. • Be sure to allow 2 to 4 inches (5.1 cm to 10.2 cm) of clearance on all sides of each pan in the oven. • Do not use dented or warped pans. • Turn oven light off while baking. |
| Foods not done when cooking time is over.  | <ul style="list-style-type: none"> • Oven too cool. • Oven overcrowded. • Oven door opened too frequently. | <ul style="list-style-type: none"> • Set oven temperature 25°F (13°C) higher than suggested and bake for the recommended time. • Be sure to remove all pans from the oven except the ones to be used for baking. • Open the oven door only after shortest recommended baking time. |

SOLUTIONS TO COMMON PROBLEMS

Before you call for service, review the following list. It may save you time and expense. Possible solutions are provided with the problem listed:

| Problem | Solution |
|--|---|
| Poor baking results | <ul style="list-style-type: none"> Many factors affect baking results. Use proper oven rack position. Center food in the oven and space pans to allow air to circulate. Preheat oven to the set temperature before placing food in the oven. Bakeware may be too lightweight or warped. Use heavier quality bakeware so foods being prepared may bake more evenly. Try adjusting the recipe's recommended temperature or baking time. |
| Appliance is not level. | <ul style="list-style-type: none"> Be sure floor is level, strong & stable enough to adequately support range. If floor is sagging or sloping, contact a carpenter to correct the situation. Poor installation. Place oven rack in center of oven. Place a level on the oven rack. Adjust leveling leg at base of appliance until the oven rack is level. Kitchen cabinet alignment may make oven appear not level. Be sure cabinets are square and have sufficient room for appliance clearance. |
| Cannot move appliance easily. Appliance must be accessible for service. | <ul style="list-style-type: none"> Carpet interferes with appliance. Provide sufficient space to lift appliance over carpet. |
| Entire appliance does not operate | <ul style="list-style-type: none"> Make sure power cord is plugged properly into outlet. Electrical power outage. Check house lights to be sure. Call your local electric company for service outage information. Service wiring is not complete. Contact your dealer, installing agent, or authorized service agent. |
| Flames inside oven or smoking from oven vent. | <ul style="list-style-type: none"> Excessive spills in oven. Grease or food spilled onto oven bottom or oven cavity. Wipe up excessive spills before starting oven. If flames or excessive smoke are present when using broil, see "Broil" on page 20. |
| Self clean does not work. | <ul style="list-style-type: none"> Oven control improperly set. Make sure the oven door is closed. Make sure you have removed the oven racks and rack ladder supports from the oven. Review "Cleaning the Oven" on page 24. |
| Soil not completely removed after self clean. | <ul style="list-style-type: none"> Self Clean was interrupted. Review "Cleaning the Oven" on page 24. Excessive spills on oven bottom. Clean before starting self clean. Failure to clean soil from the oven frame, the door liner outside the oven door gasket, and the small area at the front center of the oven bottom. These areas are not in the self cleaning area, but they get hot enough to burn on residue. Clean these areas before starting the self cleaning cycle. Burned-on residue can be cleaned with a stiff nylon brush and water or a nylon scrubber. Be careful not to damage the oven gasket. |
| Oven racks discolored or do not slide easily. | <ul style="list-style-type: none"> Oven racks left in oven cavity during self clean. Always remove oven racks from oven cavity before starting a self clean cycle. Clean using a mild abrasive cleaner following manufacturer's instructions. Rinse with clean water, dry, and replace in oven. |
| Glide racks do not slide easily. | <ul style="list-style-type: none"> Refer to "Caring for your glide racks" on page 31. |
| Oven lights do not work. | <ul style="list-style-type: none"> Be sure the oven lights are secure in their sockets. |
| Fan noise occurring after oven is turned off. | <ul style="list-style-type: none"> Some models are equipped with a cooling fan that runs during the cooking process to cool internal electronic components. It is normal for this fan to continue to run for an extended period of time, even when the oven is off. |

| | |
|--|--|
| Oven smokes excessively when broiling. | <ul style="list-style-type: none"> • Incorrect setting. Follow broiling instructions in the “Broil” section on page 20. • Meat too close to the broil element. Reposition broil rack to provide proper clearance between the meat and broil element. Remove excess fat from meat. Cut remaining fatty edges to prevent curling, but do not cut into the lean portion of the meat. • Broiler pan insert is wrong side up. Grease does not drain into broiler pan. Always place the insert on the broiler pan with the ribs up and the slots down to allow grease to drip into the pan. • Broiler pan used without insert or insert covered with aluminum foil. Do not use the broiler pan without the insert; do not cover the insert with aluminum foil. • Oven needs to be cleaned. Grease build up on oven surfaces. Regular cleaning is necessary when broiling frequently. Grease or food splatters will cause excessive smoking. |
| Surface burners do not ignite. | <ul style="list-style-type: none"> • Surface control knob has not been completely turned to  position. Push in and turn the surface control knob to  until burner ignites and then turn control knob to desired flame size. • Burner ports are clogged. With the burners OFF, use a small-gauge wire or needle to clean ports. See the “Care and Cleaning” section for complete instructions. • Appliance power cord is disconnected from outlet. Be sure power cord is securely plugged into the electrical outlet. • Electrical power outage. |
| Oven does not operate. | <ul style="list-style-type: none"> • Service wiring is incomplete. Contact your dealer, installing agent, or authorized servicer. • Power outage. Check house lights to be sure. Call your local electric company. • Short in cord/plug. Contact your dealer, installing agent, or authorized servicer to replace cord/plug. • House fuse has blown or circuit breaker has tripped immediately following installation. House fuse may not be fully engaged. Check fuse and screw or engage circuit breaker securely. |
| Surface burner flame uneven or not flaming all the way around the burner cap | <ul style="list-style-type: none"> • Burner ports are clogged. With the burner off, clean ports by using a small-gauge wire or needle. • Moisture is present after cleaning. Lightly fan the flame and allow burner to operate until flame is full. Dry the burners thoroughly and follow instructions in the “Care and Cleaning” section. |
| Surface burner flame is too high | <ul style="list-style-type: none"> • Surface control knob is set too high. Adjust to lower flame setting. • Burner caps are not seated properly. Check that all surface burner caps are level and seated correctly on surface burner heads. See “Cleaning the Sealed Burners” on page 28 for additional cleaning instructions. • Incorrect L. P. conversion. Refer to L. P. conversion kit instructions to correct. |
| Surface burner flame is orange | <ul style="list-style-type: none"> • Dust particles in main line. Use the burner for a few minutes until flame turns blue. • In coastal areas, a slightly orange flame is unavoidable due to salt air. |

WARRANTY

Your appliance is covered by a one year limited warranty. For one year from your original date of purchase, Electrolux will repair or replace any parts of this appliance that prove to be defective in materials or workmanship when such appliance is installed, used, and maintained in accordance with the provided instructions. In addition, the glass cooktop or radiant surface element of your appliance (excluding built-in and free-standing range appliances) is covered by a two through five year limited warranty. During the 2nd through 5th years from your original date of purchase, Electrolux will provide a replacement glass cooktop or radiant surface element for your appliance which has proven to be defective in materials or workmanship when such appliance is installed, used, and maintained in accordance with the provided instructions.

Exclusions

This warranty does not cover the following:

1. Products with original serial numbers that have been removed, altered or cannot be readily determined.
2. Product that has been transferred from its original owner to another party or removed outside the USA or Canada.
3. Rust on the interior or exterior of the unit.
4. Products purchased "as-is" are not covered by this warranty.
5. Products used in a commercial setting.
6. Service calls which do not involve malfunction or defects in materials or workmanship, or for appliances not in ordinary household use or used other than in accordance with the provided instructions.
7. Service calls to correct the installation of your appliance or to instruct you how to use your appliance.
8. Expenses for making the appliance accessible for servicing, such as removal of trim, cupboards, shelves, etc., which are not a part of the appliance when it is shipped from the factory.
9. Service calls to repair or replace appliance light bulbs, air filters, water filters, other consumables, or knobs, handles, or other cosmetic parts.
10. Labor or in-home service costs during the additional limited warranty periods beyond the first year from your original date of purchase.
11. Pickup and delivery costs; your appliance is designed to be repaired in the home.
12. Surcharges including, but not limited to, any after hour, weekend, or holiday service calls, tolls, ferry trip charges, or mileage expense for service calls to remote areas, including the state of Alaska.
13. Damages to the finish of appliance or home incurred during transportation or installation, including but not limited to floors, cabinets, walls, etc.
14. Damages caused by: services performed by unauthorized service companies; use of parts other than genuine Electrolux parts or parts obtained from persons other than authorized service companies; or external causes such as abuse, misuse, inadequate power supply, accidents, fires, or acts of God.

DISCLAIMER OF IMPLIED WARRANTIES; LIMITATION OF REMEDIES

CUSTOMER'S SOLE AND EXCLUSIVE REMEDY UNDER THIS LIMITED WARRANTY SHALL BE REPAIR OR REPLACEMENT AS PROVIDED HEREIN. **CLAIMS BASED ON IMPLIED WARRANTIES, INCLUDING WARRANTIES OF MERCHANTABILITY OR FITNESS FOR A PARTICULAR PURPOSE, ARE LIMITED TO ONE YEAR OR THE SHORTEST PERIOD ALLOWED BY LAW, BUT NOT LESS THAN ONE YEAR.** ELECTROLUX SHALL NOT BE LIABLE FOR CONSEQUENTIAL OR INCIDENTAL DAMAGES SUCH AS PROPERTY DAMAGE AND INCIDENTAL EXPENSES RESULTING FROM ANY BREACH OF THIS WRITTEN LIMITED WARRANTY OR ANY IMPLIED WARRANTY. SOME STATES AND PROVINCES DO NOT ALLOW THE EXCLUSION OR LIMITATION OF INCIDENTAL OR CONSEQUENTIAL DAMAGES, OR LIMITATIONS ON THE DURATION OF IMPLIED WARRANTIES, SO THESE LIMITATIONS OR EXCLUSIONS MAY NOT APPLY TO YOU. THIS WRITTEN WARRANTY GIVES YOU SPECIFIC LEGAL RIGHTS. YOU MAY ALSO HAVE OTHER RIGHTS THAT VARY FROM STATE TO STATE.

If You Need Service

Keep your receipt, delivery slip, or some other appropriate payment record to establish the warranty period should service be required. If service is performed, it is in your best interest to obtain and keep all receipts. Service under this warranty must be obtained by contacting Electrolux at the addresses or phone numbers below.

This warranty only applies in the USA, Puerto Rico and Canada. In the USA and Puerto Rico, your appliance is warranted by Electrolux Major Appliances North America, a division of Electrolux Home Products, Inc. In Canada, your appliance is warranted by Electrolux Canada Corp. Electrolux authorizes no person to change or add to any obligations under this warranty. Obligations for service and parts under this warranty must be performed by Electrolux or an authorized service company. Product features or specifications as described or illustrated are subject to change without notice.

USA

1-877-435-3287

Electrolux Major Appliances North America
10200 David Taylor Drive
Charlotte, NC 28262

Canada

1-800-265-8352

Electrolux Canada Corp.
5855 Terry Fox Way
Mississauga, Ontario, Canada L5V 3E4

electrolux.com/shop



CE

