

# **VEVOR<sup>®</sup>**

## **TOUGH TOOLS, HALF PRICE**

Technical Support and E-Warranty Certificate [www.vevor.com/support](http://www.vevor.com/support)

### **LINEAR GUIDE RAIL**

We continue to be committed to provide you tools with competitive price. "Save Half", "Half Price" or any other similar expressions used by us only represents an estimate of savings you might benefit from buying certain tools with us compared to the major top brands and does not necessarily mean to cover all categories of tools offered by us. You are kindly reminded to verify carefully when you are placing an order with us if you are actually saving half in comparison with the top major brands.

# VEVOR<sup>®</sup>

TOUGH TOOLS, HALF PRICE

## LINEAR GUIDE RAIL

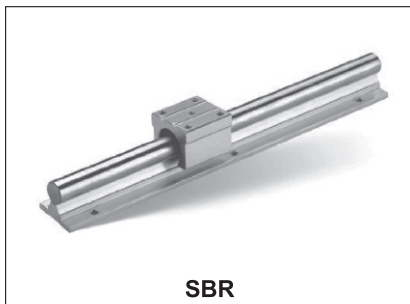

**SBR**

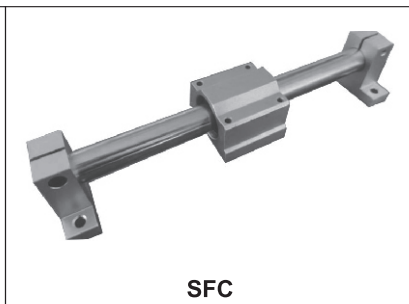

**SFC**

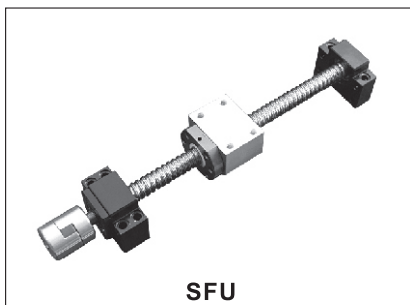

**SFU**

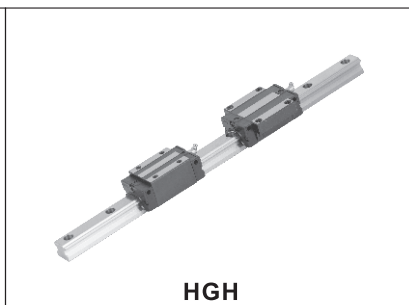

**HGH**

### NEED HELP? CONTACT US!

Have product questions? Need technical support? Please feel free to contact us:

Technical Support and E-Warranty Certificate [www.vevor.com/support](http://www.vevor.com/support)

This is the original instruction, please read all manual instructions carefully before operating. VEVOR reserves a clear interpretation of our user manual. The appearance of the product shall be subject to the product you received. Please forgive us that we won't inform you again if there are any technology or software updates on our product.

## IMPORTANT SAFETY INFORMATION



### WARNING:

Read this material before using this product. Failure to do so can result in serious injury.

### **SAVE THIS MANUAL**

### **Precautions**

1. Proper installation: Linear guide rails must be installed properly to ensure accurate and smooth motion. Improper installation can cause misalignment, binding, or excessive wear.
2. Load capacity: Be sure to use a linear guide rail with a load capacity that is sufficient for the weight of the moving part. Overloading the guide rail can cause excessive wear or permanent damage.
3. Maintenance: Regular cleaning and lubrication of the guide rail and sliding block are important to maintain proper performance and extend the service life of the guide rail.
4. Alignment: Make sure that the linear guide rail is properly aligned and perpendicular to the direction of travel to reduce friction and wear.
5. Environmental conditions: Linear guide rails should be protected from extreme temperatures, moisture, dust, and other environmental conditions that can affect performance.
6. Protection from impact: Linear guide rails should be protected from impact and other sources of shock, as these can cause damage to the rail or sliding block.
7. Inspection: Regular inspection of the guide rail and sliding block is important to identify and address any problems or wear before they become serious.

## Troubleshooting

1.Binding or sticking: This can be caused by misalignment, improper lubrication, or excessive wear. To resolve this issue, the guide rail and sliding block should be inspected and realigned if necessary, and lubricated with the appropriate grease.

2.Excessive wear: This can be caused by overloading, improper lubrication, or misalignment. To resolve this issue, the load on the guide rail should be reduced, and the guide rail and sliding block should be inspected, realigned if necessary, and lubricated with the appropriate grease.

3.Misalignment: This can be caused by improper installation or by wear over time. To resolve this issue, the guide rail and sliding block should be inspected and realigned if necessary.

4.Noisy operation: This can be caused by a lack of lubrication, misalignment, or excessive wear. To resolve this issue, the guide rail and sliding block should be lubricated with the appropriate grease, inspected and realigned if necessary.

5.Reduced accuracy: This can be caused by misalignment, binding, or excessive wear. To resolve this issue, the guide rail and sliding block should be inspected, realigned if necessary, lubricated with the appropriate grease, and checked for proper alignment.

## PRODUCT SPECIFICATIONS

### SBR LINEAR GUIDE RAIL

Rail Carriage Block(SBRxxUU)

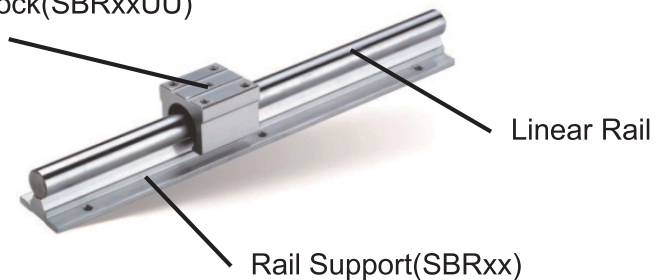

## Linear Rail

- Material:GCR15 ..... 45"
- Hardness:HRC62+2(45\*:HRC58)
- Surface Hard-thickness:0.8~2.5mm
- Surface roughness:0.8S~1.6S
- Straightness:80μm/1000mm
- Roundness:≤3.0μm(Rmax)



## Rail Carriage Block(SBRxxUU)

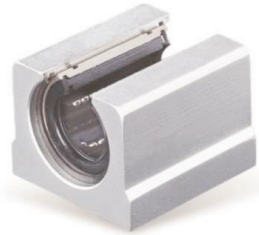
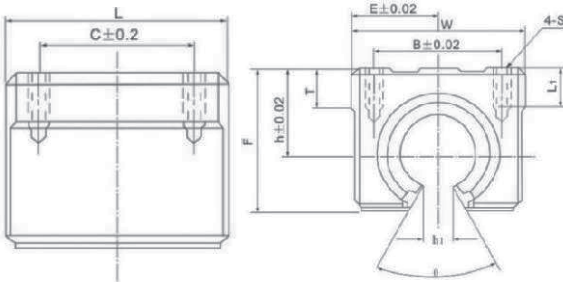

## Rail Support(SBRxx)

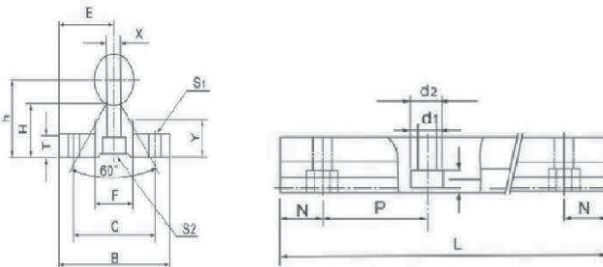

**SBR12-C 1000L**

Part name	Dimensions(mm)											
	h	E	W	L	F	h1	θ	B	C	S	L1	T
SBR12UU	17	20	40	39	27.6	6	80°	28	26	M5	10	7
Part name	Dimensions(mm)											
	Shaft Dimensions		E	h	B	H	T	F	X	Y	C	S1
SBR12	Φ12×1000L		15	22.5	32	16.5	4	12	6	12	22	Φ5

**SBR16-C 2000L,1500L,1200L,1000L,800L,600L,500L,400L,300L**

Part name	Dimensions(mm)											
	h	E	W	L	F	h1	θ	B	C	S	L1	T
SBR16UU	20	22.5	45	45	33	10	80°	32	30	M5	12	9
Part name	Dimensions(mm)											
	Shaft Dimensions		E	h	B	H	T	F	X	Y	C	S1
SBR16	Φ16×800L		20	25	40	17.8	5	18.5	8	11.7	30	Φ6

**SBR20-C 2200L,1800L,1500L,1200L,1000L,800L,650L,600L,300L**

Part name	Dimensions(mm)											
	h	E	W	L	F	h1	θ	B	C	S	L1	T
SBR20UU	23	24	48	50	39	10	60°	35	35	M6	12	11
Part name	Dimensions(mm)											
	Shaft Dimensions		E	h	B	H	T	F	X	Y	C	S1
SBR20	Φ20×1000L		22.5	27	45	17.7	5	19	8	10	30	Φ6



**SBR25-C 1200L**

Part name	Dimensions(mm)											
	h	E	W	L	F	h1	$\theta$	B	C	S	L1	T
SBR25UU	27	30	60	65	47	11.5	50°	40	40	M6	12	14
Part name	Dimensions(mm)											
	Shaft Dimensions		E	h	B	H	T	F	X	Y	C	S1
SBR25	Φ25×1200L		27.5	33	55	21	6	21.5	8	12	35	Φ6.5

# Specification table for ball screw set(SFUXX)

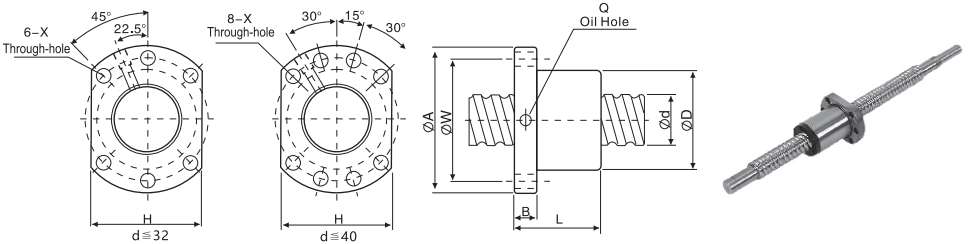

SFU1605-4 2000L,1700L,1500L,1050L,1000L,700L,650L,600L,350L

Part name	Dimensions(mm)														
	d	I	Da	D	A	B	L	W	X	H	Q	N	Ca	Coa	K
SFU1605-4	16	5	3.175	28	48	10	50	38	5.5	40	M6	4	780	1790	20

## SUPPORT UNIT BK

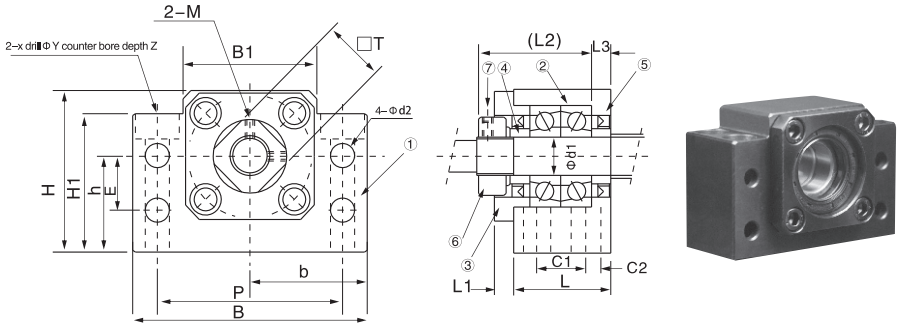

Part name	Shaft diameter d1	L	L1	L2	L3	B	H	b	h	B1	L1	E	P	C1	C2	C3	X	Y	Z	M	T
								±0.02	±0.02												
BK-12	12	25	5	29	5	60	43	30	25	35	32.5	18	46	13	6	5.5	6.5	10.8	6.5	M4	19

# SUPPORT UNIT BF

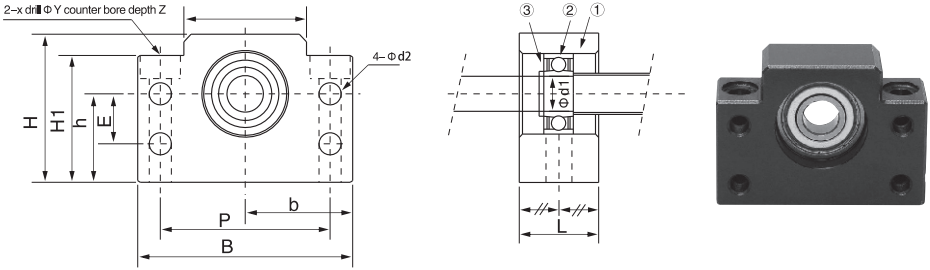

Part name	Shaft diameter d1	L	B	H	b	h	B1	H1	E	P	d2	X	Y	Z	Bearing	Snapping
					±0.02	±0.02										
BF-12	12	20	60	43	30	25	35	32.5	18	46	5.5	6.6	10.8	6.5	6000ZZ	S10

# BF series Elastic Coupling

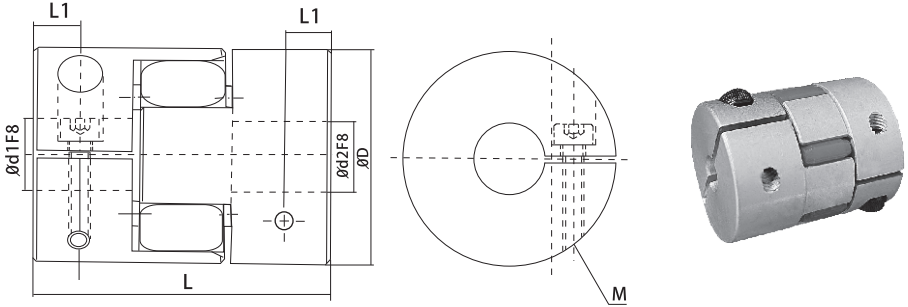

Part name	d1 Bore	d2 Bore	D	L	L1	M	Rated Torque (N.m)	Max. Torque	Eccentricity Error	Shaft Angel	Max. Rotational (rpm)	Rated
BF	5-10	5-10	25	34	5.5	M3	2N.m	35N.m	±0.2mm	≤1°	6500	In-phase Operate

# DSG1605

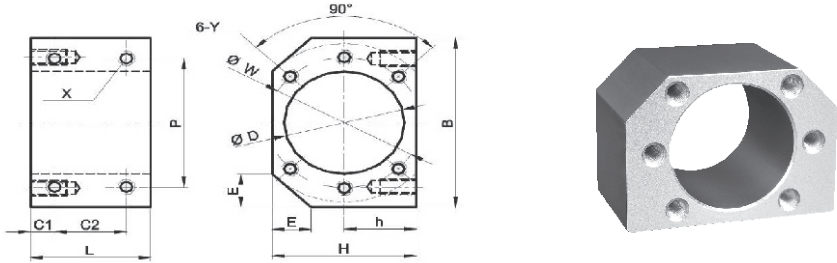

Part name	Screw model	D	B	H	h	E	L	C1	C2	P	X	W	Y
DSG 16 H	1605	28	52	40	20	12	40	8	24	40	M5	38	M5

## Dimensions for HGH Series Linear Guideways

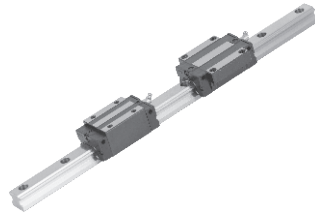
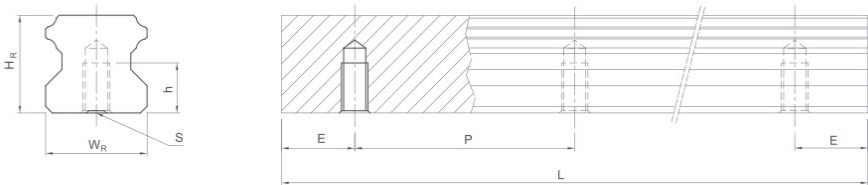

HGH15 1500L,1200L,300L  
 HGH20 2000L,1700L,1500L,1200L,1000L,700L,600L

Part name	Dimensions(mm)						Weight (kg/m)
	W <sub>R</sub>	H <sub>R</sub>	S	h	P	E	
HGH15	15	15	M5x0.8P	8	60	20	1.48
HGH20	20	17.5	M6x1P	10	60	20	2.29

# HGH-CA Series Linear Guide Slider Size Table

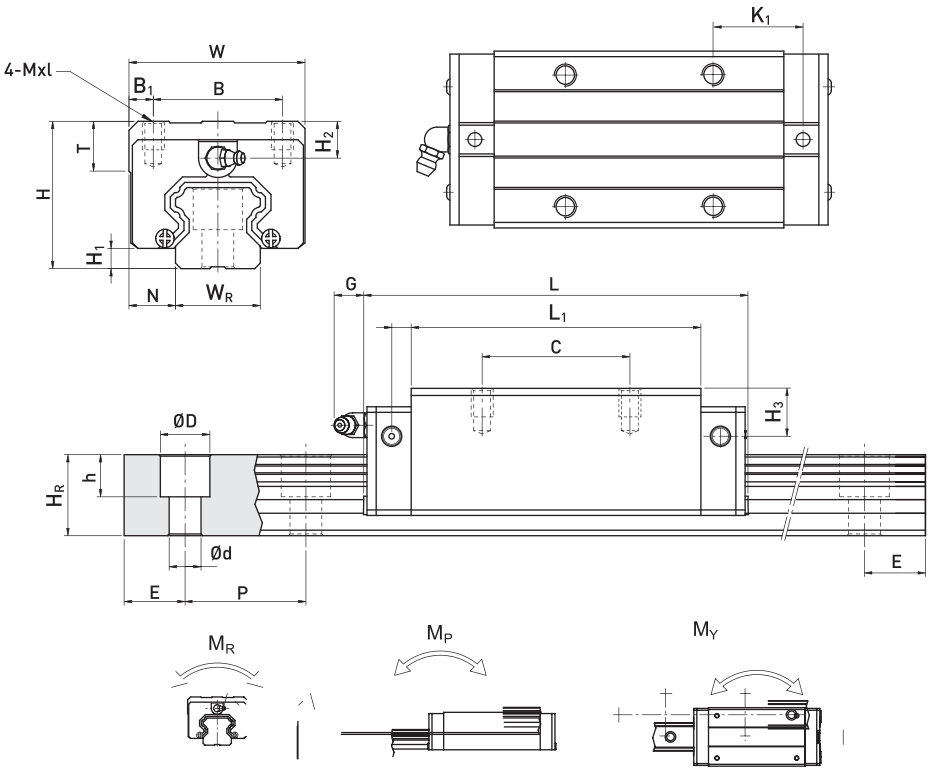

Part name	Dimensions of Assembly (mm)			Dimensions of Block (mm)										Dimensions of Rail (mm)						Mounting Bolt for Rail	Basic Dynamic Load Rating	Basic Static Load Rating			
	H	H <sub>1</sub>	N	W	B	B <sub>1</sub>	C	L <sub>1</sub>	L	K <sub>1</sub>	G	Mxl	T	H <sub>2</sub>	H <sub>3</sub>	W <sub>R</sub>	H <sub>R</sub>	D	h				d	P	e
HGH15CA	28	4.3	9.5	34	26	4	26	39.5	60.5	10	5.3	M4x5	6	7.95	7.7	15	15	7.5	5.3	4.5	60	20	M4x16	11.38	16.97
HGH20CA	30	4.6	12	44	32	6	36	50.5	76.7	12.25	12	M5x6	8	6	6	20	17.5	9.5	8.5	6	60	20	M5x16	17.75	27.76

## LINEAR SLIDE RAIL

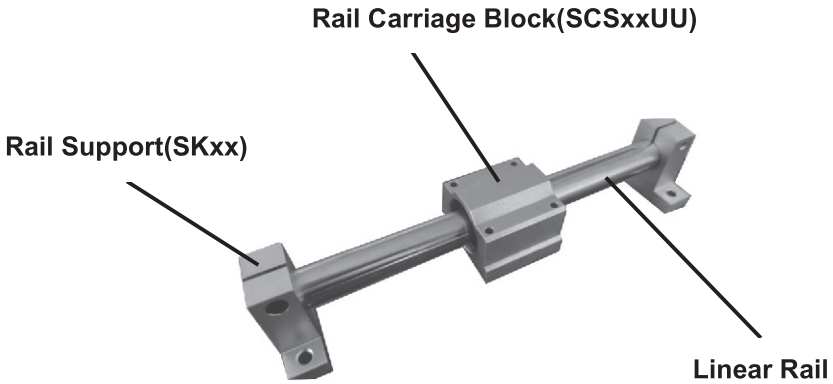

### Linear Rail

- Material:GCR15 ..... 45"
- Hardness:HRC62+2(45\*:HRC58)
- Surface hard-thickness:0.8~2.5mm
- Surface roughness:0.8S~1.6S
- Straightness:80 $\mu$ m/1000mm
- Roundness: $\leq$ 3.0 $\mu$ m(Rmax)



### Rail Carriage Block(SCSxxUU)

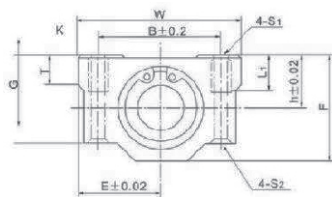
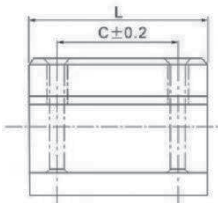

## Rail Support(SKxx)

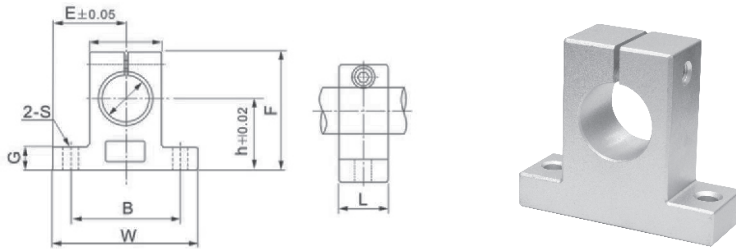

### SFC16-500L

Part name	Dimensions(mm)												
	T	h	E	W	L	F	G	B	C	K	S1	S2	L1
SCS16UU	9	19	25	50	44	38.5	32.5	36	3 4	7	M5	4.3	12
Part name	Dimensions(mm)												
	Shaf Dimensions			h	E	W	L	F	G	P	B	S	
SK16	Φ16×1000L			27	24	48	16	44	8	25	38	5.5	

### SFC16-1000L

Part name	Dimensions(mm)												
	T	h	E	W	L	F	G	B	C	K	S1	S2	L1
SCS16UU	9	19	25	50	44	38.5	32.5	36	3 4	7	M5	4.3	12
Part name	Dimensions(mm)												
	Shaf Dimensions			h	E	W	L	F	G	P	B	S	
SK16	Φ16×1000L			27	24	48	16	44	8	25	38	5.5	

## SFC20-1000L

Part name	Dimensions(mm)												
	T	h	E	W	L	F	G	B	C	K	S1	S2	L1
SCS20UU	11	21	27	54	50	41	35	40	40	7	M6	5.2	12
Part name	Dimensions(mm)												
	Shaf Dimensions	h	E	W	L	F	G	P	B	S			
SK20	Φ20×1000L	31	30	60	20	51	10	30	45	6.6			

## SFC20-1200L

Part name	Dimensions(mm)												
	T	h	E	W	L	F	G	B	C	K	S1	S2	L1
SCS20UU	11	21	27	54	50	41	35	40	40	7	M6	5.2	12
Part name	Dimensions(mm)												
	Shaf Dimensions	h	E	W	L	F	G	P	B	S			
SK20	Φ20×1200L	31	30	60	20	51	10	30	45	6.6			

**Manufacturer:** Shanghaimuxinmuyeyouxiangongsi

**Address:** Shuangchenglu 803nong11hao1602A-1609shi, baoshanqu, shanghai 200000 CN.

**Imported to AUS:** SIHAO PTY LTD, 1 ROKEVA STREETEASTWOOD NSW 2122 Australia

**Imported to USA:** Sanven Technology Ltd., Suite 250, 9166 Anaheim Place, Rancho Cucamonga, CA 91730

<b>EC</b>	<b>REP</b>
-----------	------------

E-CrossStu GmbH  
Mainzer Landstr.69, 60329 Frankfurt am Main.

<b>UK</b>	<b>REP</b>
-----------	------------

YH CONSULTING LIMITED.  
C/O YH Consulting Limited Office 147, Centurion House,  
London Road, Staines-upon-Thames, Surrey, TW18 4AX

**VEVOR<sup>®</sup>**

**TOUGH TOOLS, HALF PRICE**

**Technical Support and E-Warranty Certificate**

**[www.vevor.com/support](http://www.vevor.com/support)**

# VEVOR®

## TOUGH TOOLS, HALF PRICE

Support technique et Certificat de garantie électronique  
[www.vevor.com/support](http://www.vevor.com/support)

### GUIDE LINÉAIRE RAIL

Nous continuons à nous engager à fournir toi outils avec compétitif prix. "Sauvegarder Moitié", "Moitié Prix" ou n'importe lequel autre expressions similaires utilisé par nous seulement représente un estimation des économies que vous pourriez réaliser en achetant certain outils avec nous comparer d à le majeur haut marques et fait pas nécessairement signifie couvrir tout catégories d'outils offert par nous. Vous sont gentiment rappelez-vous de vérifier attentivement lorsque vous sont placement un commander avec nous si tu sont en fait, j'économise la moitié dans comparaison avec le haut majeur marques.

# VEVOR<sup>®</sup>

TOUGH TOOLS, HALF PRICE



SBR

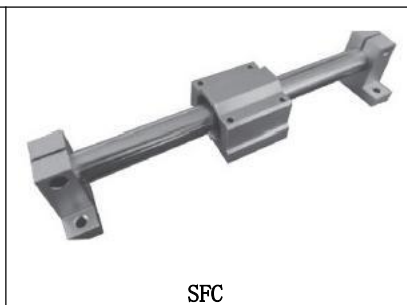

SFC



Université Simon  
Fraser



HGH

## NEED HELP?CONTACT US!

Have product questions?Need technical support?Please feel free to contact us:

Technical Support and E-Warranty Certificate [www.vevor.com/support](http://www.vevor.com/support)

Ce c'est l' instruction originale, s'il vous plaît lire tous manuel instructions soigneusement avant d'utiliser.V EVOR se réserve le droit de interprétation de notre manuel d'utilisation.L'apparence du produit sera sujet à le produit que vous avez reçu. Veuillez nous pardonner que nous ne le

ferons pas informer toi encore si il y en a technologie ou logiciel  
Mises à jour sur notre produit.



**WARNING:**

Lisez ce document avant en utilisant ce produit.Échec à faire donc peut résultat dans sérieux blessure.

**SAUVEGARDER CE MANUEL**

**Précautions**

1.Propre installation :Linéaire guide rails doit être installé correctement à assurer précis et lisse mouvement.Impropre installation peut cause m - alignement, reliure, ou excessif porter.

2.Charge capacité : assurez-vous de utiliser un guide linéaire rail avec un charger capacité que est suffisant pour le poids de la en mouvement partie.Surcharge du guide rail peut provoquer une usure excessive ou dommages permanents .

3. Entretien : Nettoyage régulier et lubrification de la guide rail et glissant bloc sont important pour maintenir bon fonctionnement et prolonger le service la vie de la guide rail.

4. Alignement : assurez-vous que le guide linéaire rail est correctement aligné et perpendiculaire au sens de déplacement pour réduire les frottements et l'usure.

5. Environnement conditions :Guidage linéaire rails devrait être protégé de températures extrêmes , humidité, poussière et autre environnemental conditions que peut affecter performance.

6. Protection contre impact : Guide linéaire les rails devraient être protégé de l'impact et d'autres sources de choc, car ceux-ci peuvent cause dommages à le rail ou glissement bloc.

## **IMPORTANT SAFETY INFORMATION**

7. Inspection : Régulière inspection du guide rail et coulissant bloc est il est important d' identifier et de résoudre tout problème ou usure avant ils devenir sérieux.

## Dépannage

1. Obligation ou coller: Ceci peut être causé par un désalignement, un mauvais fonctionnement de la lubrification, ou une usure excessive. Pour résoudre ce problème, le guide rail et le glissement du bloc devraient être

inspectés et réalignés si nécessaire, et lubrifiés avec la graisse appropriée.

2. Excessif porter: Ceci peut être causé par une surcharge, une inappropriée lubrification, ou un désalignement. Pour résoudre ce problème, la charge sur le guide rail devrait être réduite, et le guide rail et le coulissant le bloc devraient être inspectés, réalignés si nécessaire et lubrifiés avec la graisse appropriée.

3. Désalignement : Ceci peut être causé par une incorrecte installation ou un mauvais fonctionnement de la lubrification sur temps . Pour résoudre ce problème, le guide rail et le coulissant le bloc devraient être inspectés et réalignés si nécessaire.

4. Bruyant opération: Ceci peut être causé par un manque de lubrification, un désalignement ou une usure excessive. Pour résoudre ce problème, le guide rail et le glissement du bloc devraient être lubrifiés avec la graisse appropriée, inspectés et réalignés si nécessaire.

5. Réduit précision : Ceci peut être causé par un désalignement, une liaison ou un excessif porter. Pour résoudre ce problème, le guide rail et le glissement du bloc devraient être inspectés, réalignés si nécessaire, lubrifiés avec la graisse appropriée et à carreaux pour un alignement correct.

## PRODUCT SPECIFICATIONS

### SBR GUIDE LINÉAIRE RAIL

Rail Transport Bloc (SBRxxUU)



Rail linéaire

Rail Support (SBRxx)

## Linéaire Rail

- Matériau : GCR15.....45"
- Dureté : HRC62+2 (45\*:HRC58)
- Surface dure - épaisseur : 0,8 à 2,5 mm
- Rugosité de surface : 0,8 S ~ 1,6 S
- Rectitude : 80 µm/1000 mm
- Rondalité :  $\leq 3,0 \mu\text{m}$



(Rmax)

## Wagon de chemin de fer Bloc (SBRxxUU)

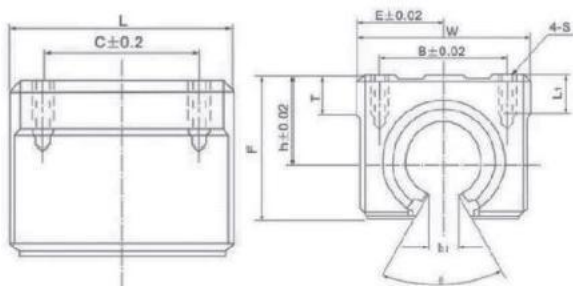

## Prise en charge ferroviaire (SBRxx)

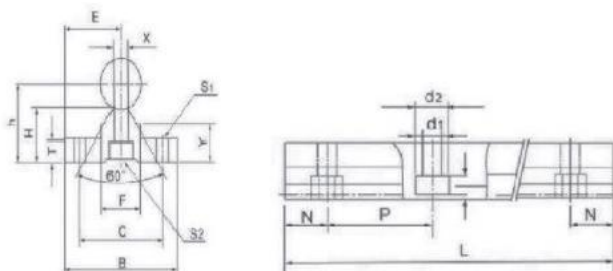

## SBR12-C 1000L

Partie nom	Dimensions (mm)											
	h	E	L	L	F	h1	θ	B	C	S	L1	T
SBR12UU	17	20	40	39	27.6	6	80°	28	26	M5	10	7
Partie nom	Dimensions (mm)											
	Arbre Dimensions		E	h	B	H	T	F	X	Y	C	S1
SBR12	Φ12×1000L		15	22,5	32	16,5	4	12	6	12	22	Φ5

## SBR16-C 2000L, 1500L, 1200L, 1000L, 800L, 600L, 500L, 400L, 300L

Partie nom	Dimensions (mm)											
	h	E	L	L	F	h1	θ	B	C	S	L1	T
SBR16UU	20	22,5	45	45	33	10	80°	32	30	M5	12	9
Partie nom	Dimensions (mm)											
	Arbre Dimensions		E	h	B	H	T	F	X	Y	C	S1
SBR16	Φ16×800L		20	25	40	17.8	5	18,5	8	11.7	30	Φ6

## SBR20-C 2200L, 1800L, 1500L, 1200L, 1000L, 800L, 650L, 600L, 300L

Partie nom	Dimensions (mm)											
	h	E	L	L	F	h1	θ	B	C	S	L1	T
SBR20UU	23	24	48	50	39	10	60°	35	35	M6	12	11
Partie nom	Dimensions (mm)											
	Arbre Dimensions		E	h	B	H	T	F	X	Y	C	S1
SBR20	Φ20×1000L		22,5	27	45	17.7	5	19	8	10	30	Φ6

## SBR25-C 1200L

Partie nom	Dimensions (mm)											
	h	E	L	L	F	h1	$\theta$	B	C	S	L1	$\tau$
SBR25UU	27	30	60	65	47	11.5	50°	40	40	M6	12	14
Partie nom	Dimensions (mm)											
	Arbre Dimensions		E	h	B	H	T	F	X	Y	C	S1
SBR25	$\Phi 25 \times 1200L$		27,5	33	55	21	6	21,5	8	12	35	$\Phi 6,5$

## Spécification tableau pour balle vis ensemble(SFU XX)

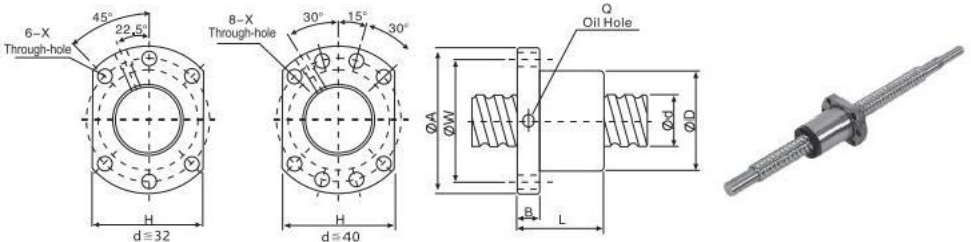

SFU1605-42000L, 1700L, 1500L, 1050L, 1000L, 700L, 650L, 600L, 350L

Partie nom	Dimensions (mm)														
	d	l	Oui	D	UN	B	L	L	X	H	Q	N	Califorie	Coa	K
SFU1605-4	16	5	3.175	28	48	10	50	38	5.5	40	M6	4	780	1790	20

## SOUTIEN UNITÉ BK

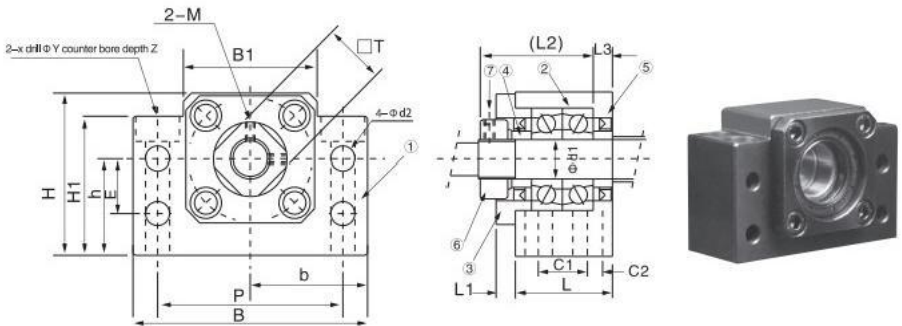

Partie nom	Arbre diamètre d1	L	L1	L2	L3	B	H	b		h	B1	L1	E	P.	C1	C2	C3	X	Ou i	Z	M.	T
								±0,02	±0,02													
BK-12	12	25	5	29	5	60	43	30	25	35	32,5	18	46	13	6	5.5	6.5	10.8	6.5	M4	19	



# SOUTIEN UNITÉ BF

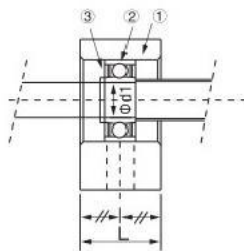
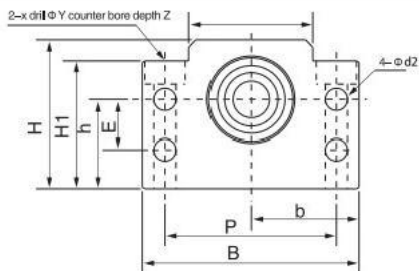

Partie nom	Arbre diamètre d1	L	B	H	b	h	B1	H1	E	P	d2	X	Y	Z	Palier	Anneau élastique
					$\pm 0,02$	$\pm 0,02$										
BF-12	12	20	60	43	30	25	35	32,5	18	46	5.5	6.6	10.8	6.5	6000ZZ	S10

## BF série Élastique Couplage

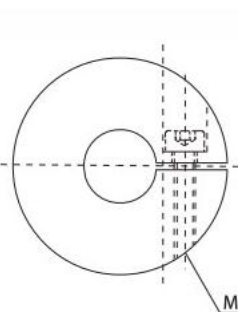
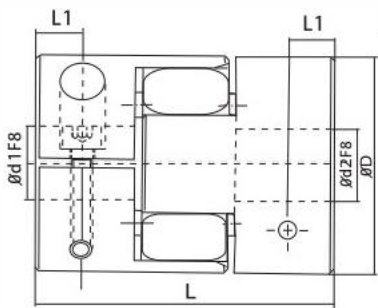

Partie nom	d1 Alésage	d2 Alésage	D	L	L1	M	Noté Couple (Nm)	Max. Couple	Excentricité y Erreur	Arbre Angle	Max. Rotationnelle (tr/min)	Noté
BF	5-10	5-10	25	34	5.5	M3	2 N.m	35 N.m	$\pm 0,2$ mm	$\leq 1^\circ$	6500	



## DSG1605

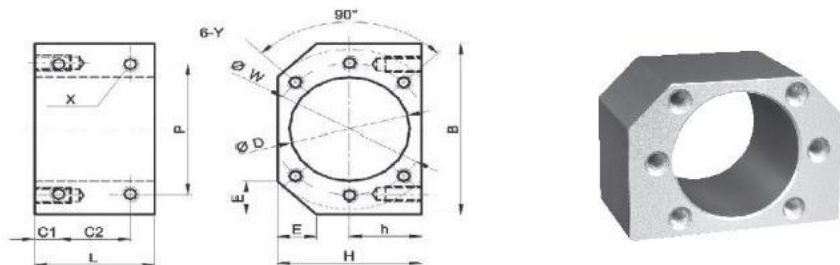

Partie nom	Vis modèle	D	B	H	h	E	L	C1	C2	P	X	L	Y
DSG 16 H	1605	28	52	40	20	12	40	8	24	40	M5	38	M5

## Dimensions de la série HGH Guidages linéaires

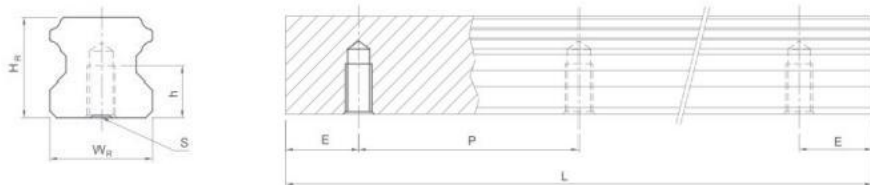

HGH151500L,1200L,300L

HGH202000L,1700L,1500L,1200L,1000L,700L,600L

Partie nom	Dimensions (mm)						Poids (kg/m)
	L	H	S	h	P	E	
HGH15	15	15	M5x0,8P	8	60	20	1.48
HGH20	20	17,5	M6x1P	10	60	20	2.29

# HGH-CA Séries Linéaire Guide    Curseur Taille Tableau

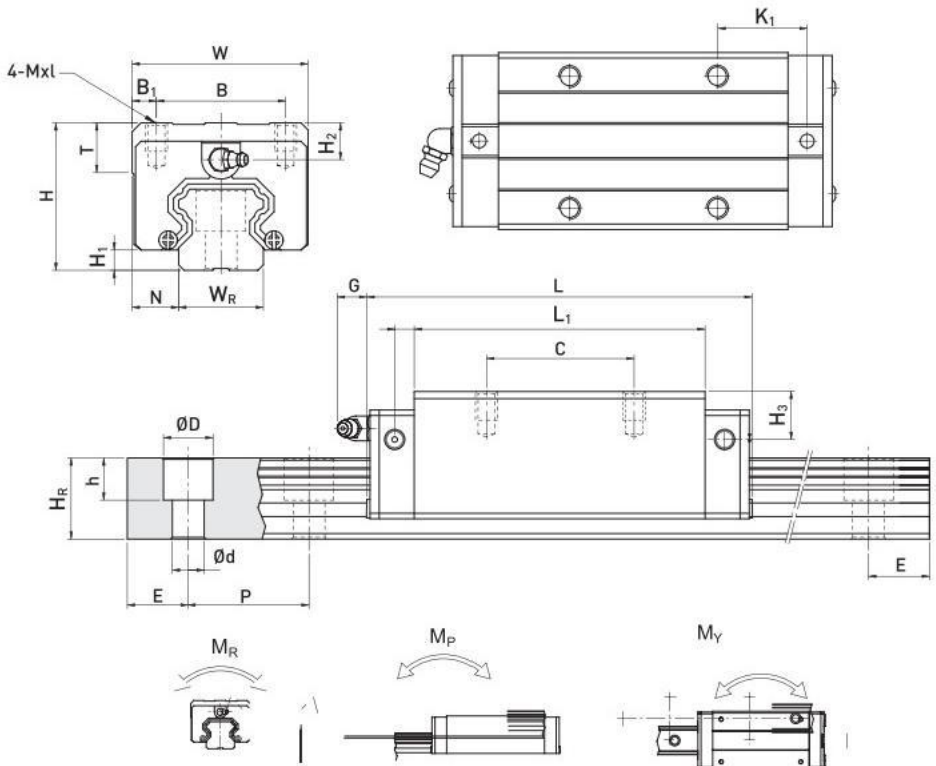

Partie nom	Dimensions de l'Assemblée (mm)			Dimensions de Bloc (mm)										Dimensions de Rail (mm)					Montage en Boîte pour Rail	Basiq ue D ynamiqu e Char ger Notati on	Basiq ue Statiq ue Char ger Notati on				
	H	H	N	L	B	B <sub>1</sub>	C	L	L	K	G	Mx1	T	H <sub>2</sub>	H <sub>3</sub>	L	H	D				h	d	P.	e
HGH15CA	28	4.3	9.5	34	26	4	26	39,5	60,5	10	5.3	M4x5	6	7,9	7.7	15	15	7.5	5.3	4.5	60	20	M4x16	11,38	16,97
HGH20CA	30	4.6	12	44	32	6	36	50,5	76,7	2,2	5	M5x6	8	6	6	20	17,5	9.5	8,5	6	60	20	M5x16	17,75	27,76



## GLISSIÈRE LINÉAIRE RAIL

### Wagon de chemin de fer Bloc (SCS xxUU)



### Linéaire Rail

- Matériau : GCR15.....45"
- Dureté : HRC62+2 (45\*:HRC58)
- Épaisseur de surface dure : 0,8 à 2,5 mm
- Rugosité de surface : 0,8 S ~ 1,6 S
- Rectitude : 80  $\mu$ m/1000 mm
- Rondalité :  $\leq 3,0 \mu$ m (Rmax)



### Wagon de chemin de fer Bloc (SCSxxUU)

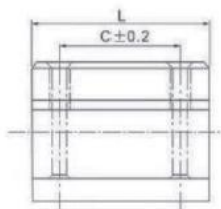

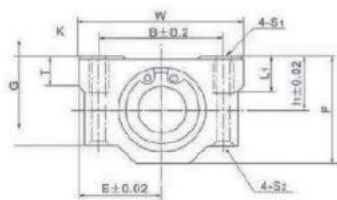

## Assistance ferroviaire (SKxx)

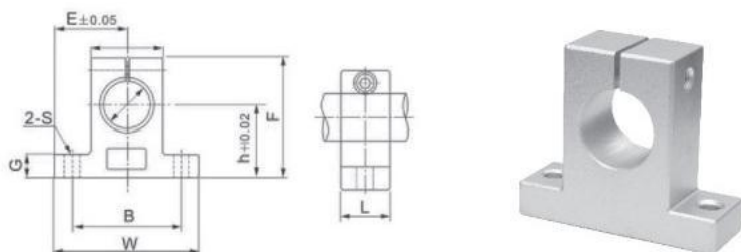

### SFC16-500L

Partie nom	Dimensions (mm)												
	T	h	E	L	L	F	G	B	C	K	S1	S2	L1
SCS16UU	9	19	25	50	44	38,5	32,5	36	$\frac{3}{4}$	7	M5	4.3	12
Partie nom	Dimensions (mm)												
	Arbre Dimensions			h	E	L	L	F	G	P	B	S	
SK16	φ 16×1000L			27	24	48	16	44	8	25	38	5.5	

### SFC16-1000L

Partie nom	Dimensions (mm)												
	T	h	E	L	L	F	G	B	C	K	S1	S2	L1
SCS16UU	9	19	25	50	44	38,5	32,5	36	$\frac{3}{4}$	7	M5	4.3	12
Partie nom	Dimensions (mm)												
	Arbre Dimensions			h	E	L	L	F	G	P	B	S	
SK16	φ 16×1000L			27	24	48	16	44	8	25	38	5.5	

**SFC20-1000L**

Part ie nom	Dimensions (mm)												
	T	h	E	L	L	F	G	B	C	K	S1	S2	L1
SCS20UU	11	21	27	54	50	41	35	40	40	7	M6	5.2	12
Part ie nom	Dimensions (mm)												
	Arbre Dimensions		h	E	L	L	F	G	P	B	S		
SK20	Φ 20×1000L		31	30	60	20	51	10	30	45	6.6		

**SFC20-1200L**

Part ie nom	Dimensions (mm)												
	T	h	E	L	L	F	G	B	C	K	S1	S2	L1
SCS20UU	11	21	27	54	50	41	35	40	40	7	M6	5.2	12
Part ie nom	Dimensions (mm)												
	Shaf Dimensions		h	E	W	L	F	G	P.	B	S		
SK20	Φ 20×1200L		31	30	60	20	51	10	30	45	6.6		

**Fabricant :** Shanghaimu xinmuyeyouxiangongsi

**Adresse:** Shuangchenglu 803nong11hao1602A-1609shi,baoshanqu, shanghai 200000 CN.

**Importé à AUS :** SIHAO PTYLTD, 1 ROKEVASTREETEASTWOOD NSW 2122 Australie

**Importé à États-Unis :** Sanven Technologie Ltd., Suite 250 9166 Anaheim Lieu, Rancho Cucamonga, CA91730

EC	REP
----	-----

E-CrossStu GmbH  
Mayence Rue Landstr. 69,60329 Francfort suis Principal.

UK	REP
----	-----

YH CONSULTING LIMITÉ.  
Avec l'aimable autorisation de YH Consultant Limité  
Bureau 147, Centurion Maison, Route de Londres,  
Staines-upon-Thames, Surrey, TW184AX

**VEVOR**<sup>®</sup>

**TOUGH TOOLS, HALF PRICE**

**Support technique et Certificat de garantie  
électronique [www.vevor.com/support](http://www.vevor.com/support)**

# VEVOR®

## TOUGH TOOLS, HALF PRICE

Technischer Support und E-Garantie-Zertifikat  
[www.vevor.com/support](http://www.vevor.com/support)

### LINEARFÜHRUNG SCHIENE

Wir sind weiterhin bestrebt, Du Werkzeuge mit wettbewerbsfähig Preis.  
"Speichern Halb", "Halb Preis" oder beliebig andere ähnliche Ausdrücke gebraucht von  
uns nur repräsentiert ein  
Schätzung der Einsparungen, die Sie durch den Kauf erzielen könnten bestimmt  
Werkzeuge mit uns Vergleiche d Zu Die wesentlich  
Spitze Marken Und tut nicht unbedingt bedeuten alles abdecken Kategorien von  
Werkzeugen angeboten von uns.Sie  
Sind freundlich Bitte überprüfen Sie sorgfältig, wenn Sie Sind Platzierung ein Bestellen  
mit uns wenn du Sind  
tatsächlich die Hälfte sparen In Vergleich mit Die Spitze wesentlich  
Marken.

# VEVOR®

TOUGH TOOLS, HALF PRICE



SBR

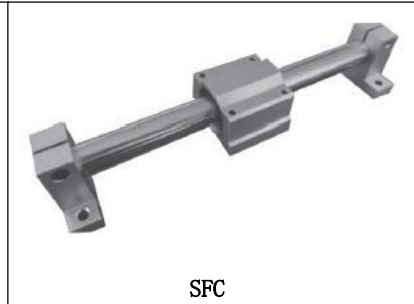

SFC

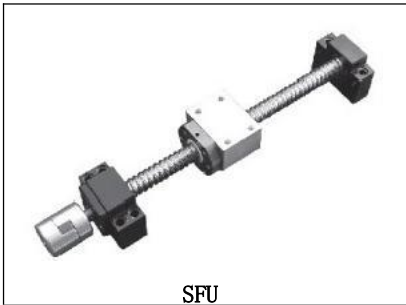

SFU



Wachstumshormon

## NEED HELP?CONTACT US!

Have product questions?Need technical support?Please feel free to contact us:

Technical Support and E-Warranty Certificate [www.vevor.com/support](http://www.vevor.com/support)

Das ist die Originalanleitung, bitte lesen alle Handbuch Anweisungen sorgfältig vor der Inbetriebnahme.V EVOR behält sich eine klare Interpretation von unser Benutzerhandbuch.Das Aussehen des Produkts soll sein Thema Zu Die Produkt, das Sie erhalten haben. Bitte verzeihen Sie uns, dass wir nicht in Form Du wieder Wenn es gibt irgendwelche Technologie oder Software Aktualisierung An unser Produkt.





**WARNING:**

Lesen Sie dieses Material, bevor Sie mit Das Produktfehler Zu Tun Also dürfen Ergebnis In ernst Verletzung.

**SPEICHERN DAS HANDBUCH**

**Vorsichtsmaßnahmen**

1.Richtig Installation :Linear Führung Schienen muss Sei installiert richtig Zu sicherstellen genau Und glatt Bewegung.Unsachgemäße Installation dürfen Ursache m istAusrichtung, Bindung oder übermäßig tragen.

2.Laden Kapazität: Achten Sie darauf, verwenden Sie eine Linearführung Schiene mit A laden Kapazität Das Ist ausreichend für das Gewicht der Umzug Teil.Überlastung der Führung Schiene dürfen übermäßigen Verschleiß verursachen oder Dauerhafter Schaden.

3.Wartung:Regelmäßige Reinigung Und Schmierung der Führung Schiene und Gleiten Block Sind wichtig für pflegen ordnungsgemäße Leistung und verlängern den Service Leben der Führung Schiene.

4.Ausrichtung: Stellen Sie sicher, dass die Linearführung Schiene Ist richtig ausgerichtet und senkrecht zur Fahrtrichtung, um Reibung und Verschleiß zu verringern.

5.Umwelt Bedingungen:Linearführung Schienen sollen Sei geschützt vor extreme Temperaturen, Feuchtigkeit, Staub und andere Umwelt Bedingungen Das dürfen beeinflussen Leistung.

6.Schutz vor Auswirkung: Linearführung Schienen sollten Sei geschützt vor Stößen und anderen Schockquellen, da diese Ursache Schäden an Die Schiene oder Gleiten Block.

## IMPORTANT SAFETY INFORMATION

---

7. Inspektion: Regelmäßig Inspektion des Leitfadens Schiene und Schiebe Block Ist wichtig, Probleme oder Verschleiß zu identifizieren und zu beheben , bevor Sie werden ernst.

## Fehlerbehebung

1. Verbindlichkeit oder kleben: Diese dürfen weil von Fehlausrichtung, Fehlbedienung Schmierung oder übermäßiger Verschleiß. lösen Sie dieses Problem, das Führung Schiene Und Gleiten Block sollen Sei inspiziert und neu ausgerichtet wenn nötig, und geschmiert mit dem geeignet Fett.

2. Übermäßig tragen: Diese dürfen Sei verursacht von Überlastung, unsachgemäße Schmierung oder Fehlausrichtung. lösen Das Problem, das laden An Die Führung Schiene sollen Sei reduziert, und der Führer Schiene und Schiebe Block sollte Sei geprüft, neu ausgerichtet Wenn und mit dem entsprechenden Fett geschmiert.

3. Fehlausrichtung : Dies dürfen weil von unsachgemäß Installation oder von tragen über Zeit . Zu lösen Sie dieses Problem, der Leitfaden Schiene und Schiebe Block sollte Sei inspiziert Und neu ausgerichtet, wenn notwendig.

4. Laut Bedienung: Diese dürfen weil von A Mangel von Schmierung, Fehlausrichtung oder übermäßiger Verschleiß. lösen Sie dieses Problem, das Führung Schiene Und gleiten Block sollen Sei geschmiert mit dem geeignet Fett, geprüft Und neu ausgerichtet Wenn notwendig.

5. Reduziert Genauigkeit: Diese dürfen Sei verursacht von Fehlausrichtung, Verklemmen oder übermäßig tragen. Zu lösen Sie dieses Problem, das Führung Schiene Und Gleiten Block sollen Sei geprüft, neu ausgerichtet Wenn ggf. geschmiert mit Die geeignet Fett und geprüft für richtige Ausrichtung.

## PRODUCT SPECIFICATIONS

### SBR LINEARFÜHRUNG SCHIENE

Schiene Wagen Blockieren (SBRxxUU)



## Linear Schiene

- Material: GCR15...45 Zoll
- Härte: HRC62+2 (45\*:HRC58)
- Oberflächenhart-Dicke: 0,8 ~ 2,5 mm
- Oberflächenrauheit: 0,8 S ~ 1,6 S
- Geradheit: 80 µm/1000 mm
- Rundheit:  $\leq 3,0 \mu\text{m}$  (Rmax)



## Schienenverkehr Blockieren (SBRxxUU)

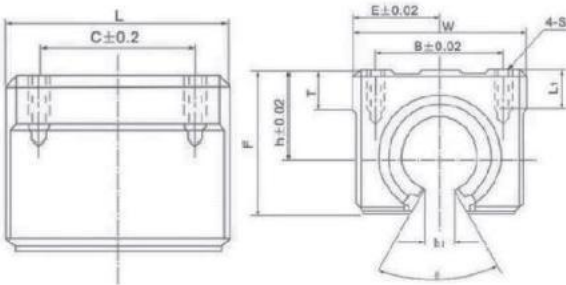

## Schienenunterstützung (SBRxx)

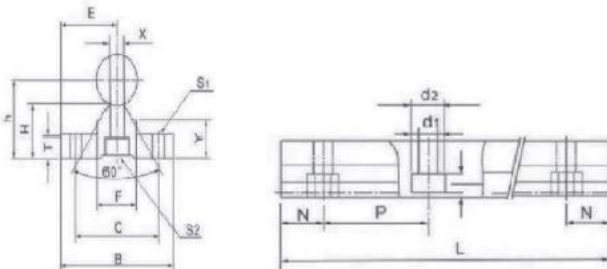

## SBR12-C 1000 Liter

Teil Name	Abmessungen (mm)											
	H	E	B	M	F	h1	θ	B	C	S	L1	T
SBR12UU	17	20	40	39	27,6	6	80°	28	26	BMW M5	10	7
Teil Name	Abmessungen (mm)											
	Welle Maße		E	H	B	H	T	F	X	Y	C	Staffel 11
SBR12	φ12×1000L		15	22,5	32	16,5	4	12	6	12	22	φ5

## SBR16-C 2000 I, 1500 I, 1200 I, 1000 I, 800 I, 600 I, 500 I, 400 I, 300 I

Teil Name	Abmessungen (mm)											
	H	E	B	M	F	h1	θ	B	C	S	L1	T
SBR16UU	20	22,5	45	45	33	10	80°	32	30	BMW M5	12	9
Teil Name	Abmessungen (mm)											
	Welle Maße		E	H	B	H	T	F	X	Y	C	Staffel 11
SBR16	φ16×800L		20	25	40	17,8	5	18,5	8	11,7	30	φ6

## SBR20-C 2200 I, 1800 I, 1500 I, 1200 I, 1000 I, 800 I, 650 I, 600 I, 300 I

Teil Name	Abmessungen (mm)											
	H	E	B	M	F	h1	θ	B	C	S	L1	T
SBR20UU	23	24	48	50	39	10	60°	35	35	M6	12	11
Teil Name	Abmessungen (mm)											
	Welle Maße		E	H	B	H	T	F	X	Y	C	Staffel 11
SBR20	φ20×1000L		22,5	27	45	17,7	5	19	8	10	30	φ6

## SBR25-C 1200L

Teil Name	Abmessungen (mm)											
	H	E	B	M	F	h1	$\theta$	B	C	S	L1	$\tau$
SBR25UU	27	30	60	65	47	11.5	50°	40	40	M6	12	14
Teil Name	Abmessungen (mm)											Staf fel 1
	Welle Maße		E	H	B	H	T	F	X	Y	C	
SBR25	$\Phi 25 \times 1200L$		27,5	33	55	21	6	21,5	8	12	35	$\Phi 6,5$

# Spezifikation Tisch für Ball schrauben Satz (SFU XX)

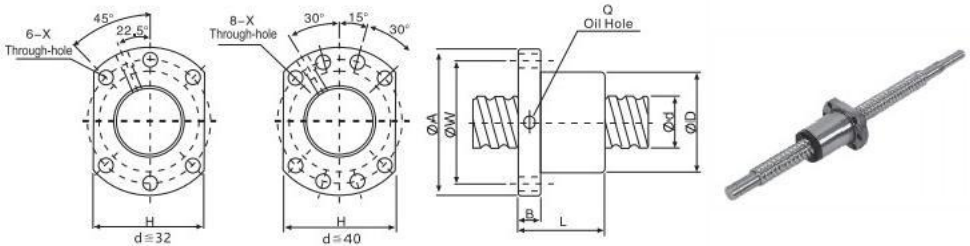

SFU1605-42000L, 1700L, 1500L, 1050L, 1000L, 700L, 650L, 600L, 350L

Teil Name	Abmessungen (mm)														
	D	I	Da	D	A	B	M	B	X	H	Q	N	Ca	Echtheitszertifika-t	K
SFU1605-4	16	5	3.175	28	48	10	50	38	5.5	40	M6	4	780	1790	20

## UNTERSTÜTZUNG EINHEIT BK

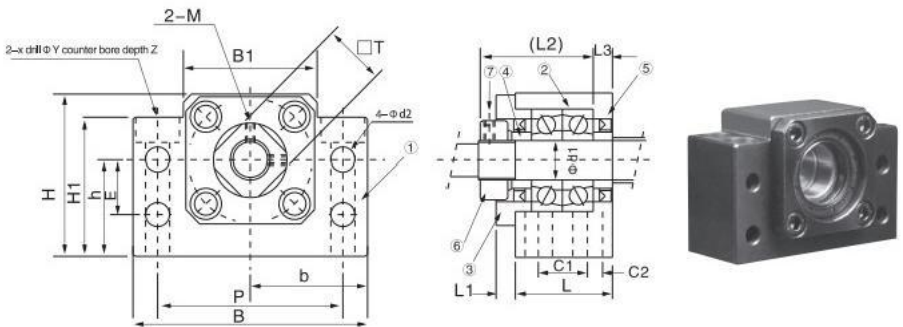

Teil Name	Welle Durchmesser n d1	L	L1	L2	L3	B	H	B	H	B1	L1	E	P	C1	C2	C3	X	Y	Z	M	T
		±0,02	±0,02																		
BK-12	12	25	5	29	5	60	43	30	25	35	32.5	18	46	13	6	5.5	6.5	10.8	6.5	M4	19



# UNTERSTÜTZUNG EINHEIT BF

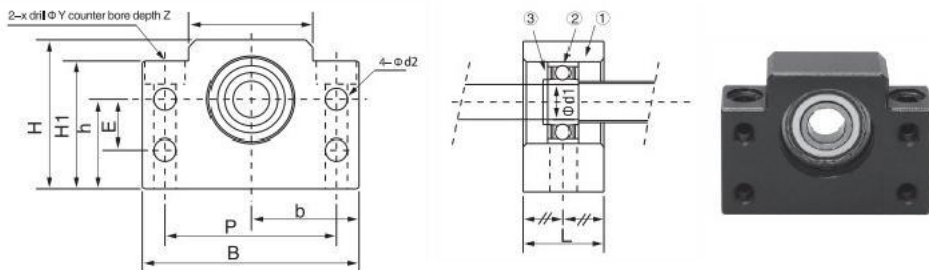

Teil Name	Welle Durchmesser d1	M	B	H	B	H	B1	H1	E	P	d2	X	Y	Z	Lager	Schnapping
					$\pm 0,02$	$\pm 0,02$										
BF-12	12	20	60	43	30	25	35	32,5	18	46	5.5	6.6	10.8	6.5	6000ZZ	Staffe 1 10

## BF Serie Elastisch Kupplung

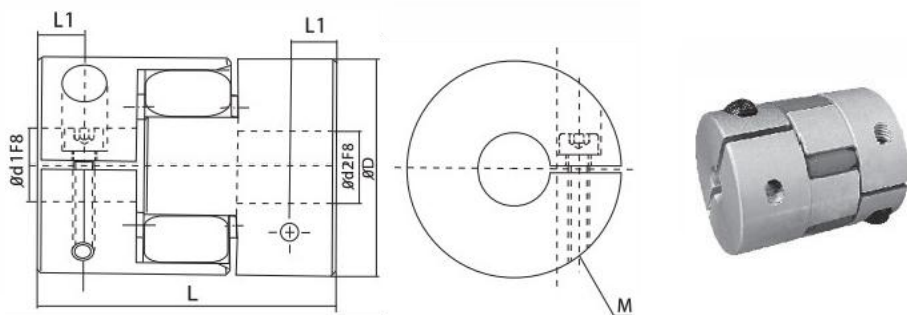

Teil Name	d1 Bohrung	d2 Bohrung	D	M	L1	M	Bewertet Drehmoment (Nm)	Max. Drehmoment	Exzentrizität Fehler	Welle Engel	Max. Rotations (U/min)	Bewertet
BF	5-10	5-10	25	34	5.5	BMW M3	2N. m	35N. m	$\pm 0,2$ mm	$\leq 1^\circ$	6500	



## DSG1605

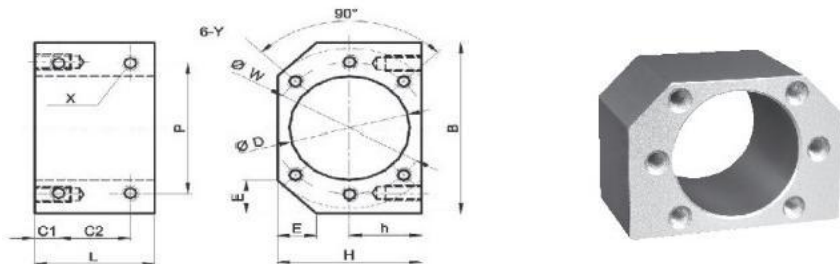

Teil Name	Schrauben Model l	D	B	H	H	E	M	C1	C2	P	X	B	Y
DSG 16 H	1605	28	52	40	20	12	40	8	24	40	BMW M5	38	BMW M5

## Abmessungen für die HGH-Serie Linearführungen

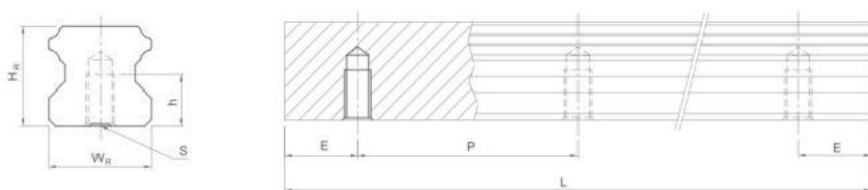

HGH151500L, 1200L, 300L

HGH202000L, 1700L, 1500L, 120 0L, 1000L, 700L, 600L

Teil Name	Abmessungen (mm)						Gewicht (kg/m)
	B	H	S	H	P	E	
HGH15	15	15	M5x0,8P	8	60	20	1,48
HGH20	20	17,5	M6x1P	10	60	20	2,29



# HGH-CA Serie Linear Führung Schieberegler Größe Tisch

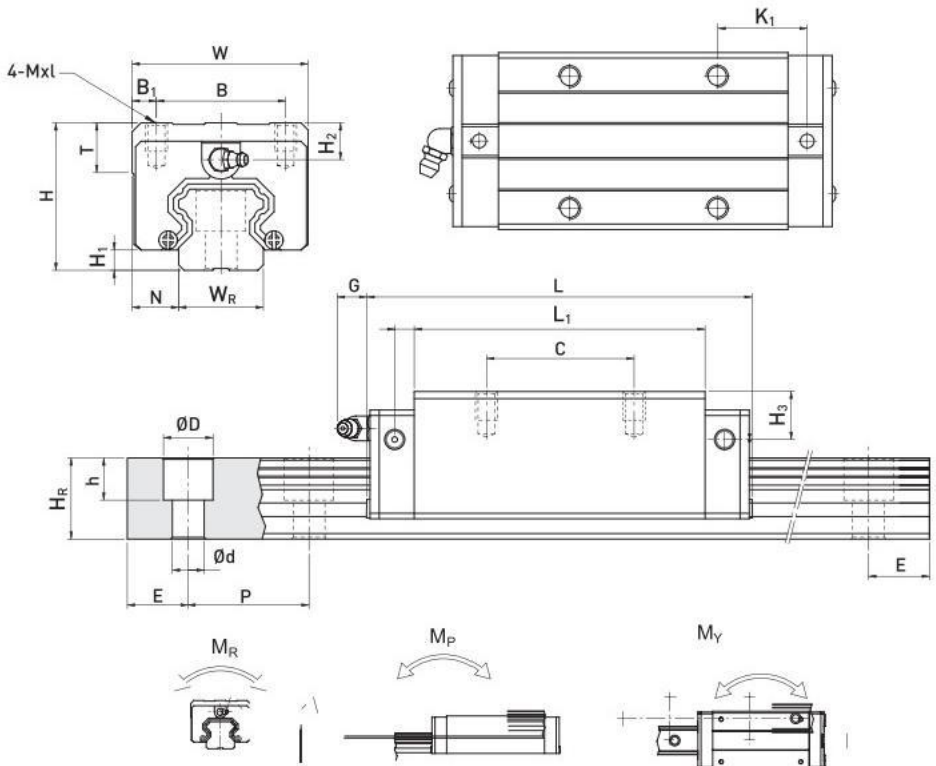

Teil Name	Maße der Versammlung (mm)			Maße von Block (mm)										Maße von Schiene (mm)					Montierung in g Besk für Rai	Basic Dynamisch Laden Ratte in g	Basic Statisch Laden Bewertungen				
	H	H	N	B	B	B <sub>1</sub>	C	M	M	K	G	Mx1	T	H <sub>2</sub>	H <sub>3</sub>	B	H	D				H	D	P	e
HGH15CA	28	4.3	9.5	34	26	4	26	39.5	60.5	10	5.3	M4x5	6	7.9	7.7	15	15	7.5	5.3	4.5	60	20	M4x16	11,38	16,97
HGH20CA	30	4.6	12	44	32	6	36	50.5	76.7	2.2	12	M5x6	8	6	6	20	17.9	9.5	8.5	6	60	20	M5x16	17,75	27,76



## LINEARSCHLITTEN SCHIENE

### Schienenverkehr Block (SCS xxUU)

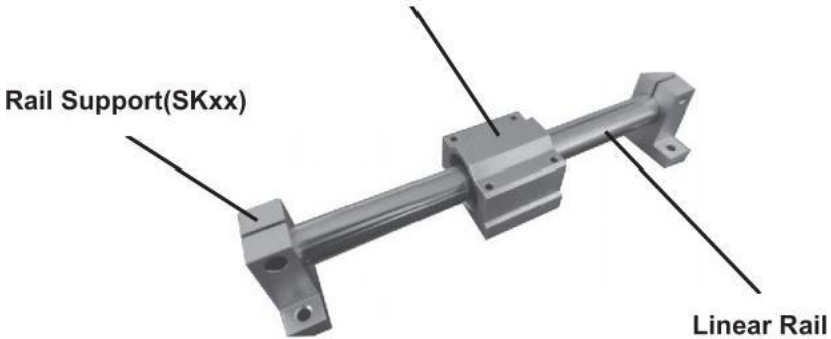

### Linear Schiene

- Material: GCR15...45 Zoll
- Härte: HRC62+2 (45\*:HRC58)
- Oberflächenhartschichtdicke: 0,8 ~ 2,5 mm
- Oberflächenrauheit: 0,8 S ~ 1,6 S
- Geradheit: 80  $\mu\text{m}/1000\text{ mm}$
- Rundheit:  $\leq 3,0\ \mu\text{m}$  (Rmax)



### Schienenverkehr Blockieren (SCSxxUU)

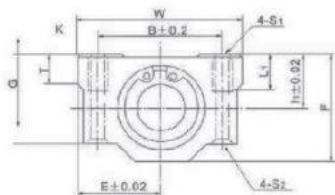
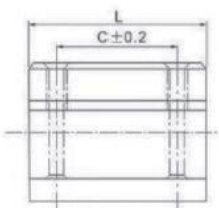

# Schienenunterstützung (SKxx)

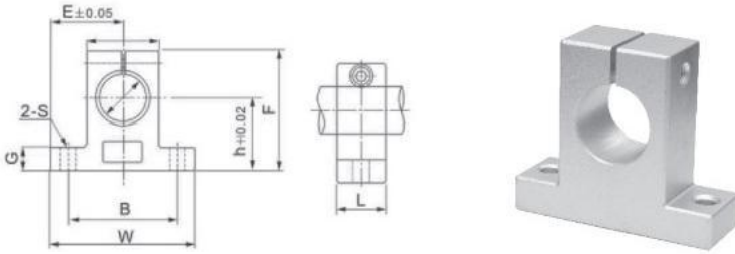

## SFC16-500L

Teil Name	Abmessungen (mm)												
	T	H	E	B	M	F	G	B	C	K	Staffe 1 1	Staffe 1 2	L1
SCS16UU	9	19	25	50	44	38,5	32,5	36	3 4	7	BMW M5	4.3	12
Teil Name	Abmessungen (mm)												
	Schaf Maße			H	E	B	M	F	G	P	B	S	
SK16	φ 16×1000L			27	24	48	16	44	8	25	38	5.5	

## SFC16-1000L

Teil Name	Abmessungen (mm)												
	T	H	E	B	M	F	G	B	C	K	Staffe 1 1	Staffe 1 2	L1
SCS16UU	9	19	25	50	44	38,5	32,5	36	3 4	7	BMW M5	4.3	12
Teil Name	Abmessungen (mm)												
	Schaf Maße			H	E	B	M	F	G	P	B	S	
SK16	φ 16×1000L			27	24	48	16	44	8	25	38	5.5	

## SFC20-1000L

Teil Name	Abmessungen (mm)												
	T	H	E	B	M	F	G	B	C	K	Staffe 1 1	Staffe 1 2	L1
SCS20UU	11	21	27	54	50	41	35	40	40	7	M6	5.2	12
Teil Name	Abmessungen (mm)												
	SchäF Maße		H	E	B	M	F	G	P	B	S		
SK20	Φ 20×1000L		31	30	60	20	51	10	30	45	6.6		

## SFC20-1200L

Teil Name	Abmessungen (mm)												
	T	H	E	B	M	F	G	B	C	K	Staffe 1 1	Staffe 1 2	L1
SCS20UU	11	21	27	54	50	41	35	40	40	7	M6	5.2	12
Teil Name	Abmessungen (mm)												
	SchäF Abmessungen		H	E	W	L	F	G	P	B	S		
SK20	Φ 20×1200L		31	30	60	20	51	10	30	45	6.6		

**Hersteller:** Shanghaimu xinmuyeyouxiangongsi

**Adresse:** Shuangchenglu 803nong11hao1602A-1609shi,baoshanqu,  
shanghai 200000 CN.

**Importiert Zu AUS:** SIHAO PTYLTD,1 ROKEVASTREETEASTWOOD  
NSW 2122 Australien

**Importiert Zu USA:** Sanven Technologie GmbH, Suite 250.9166 Anaheim  
Ort, Rancho Cucamonga, CA91730

EC	REP
----	-----

E-CrossStu GmbH  
Mainzer Landstr.69,60329 Frankfurt Bin Hauptsächlich.

UK	REP
----	-----

YH-BERATUNG BESCHRÄNKT.

C/O YH Beratung Beschränkt Büro 147,Zenturio Haus,  
London Road, Staines-upon-Thames, Surrey, TW184AX

**VEVOR<sup>®</sup>**

**TOUGH TOOLS, HALF PRICE**

**Technischer Support und E-Garantie-  
Zertifikat ate [www.vevor.com/support](http://www.vevor.com/support)**

# VEVOR®

TOUGH TOOLS, HALF PRICE

Supporto tecnico e Certificato di garanzia elettronica

[www.vevor.com/support](http://www.vevor.com/support)

## GUIDA LINEARE SBARRA

Continuiamo ad impegnarci a fornire Voi strumenti con competitivo prezzo.

"Salva Metà", "Metà Prezzo" o Qualunque altro espressioni simili usato di noi soltanto rappresenta UN

stima dei risparmi che potresti ottenere acquistando certo utensili con noi confrontare d A IL maggiore

superiore marche E fa non necessariamente significare coprire tutto categorie di strumenti offerto di noi.tu

Sono gentilmente ricordato di verificare attentamente quando si Sono collocamento UN ordina con noi se tu Sono

effettivamentersparmiandometà In confronto con IL superiore maggiore marchi.

# VEVOR<sup>®</sup>

TOUGH TOOLS, HALF PRICE



SBR

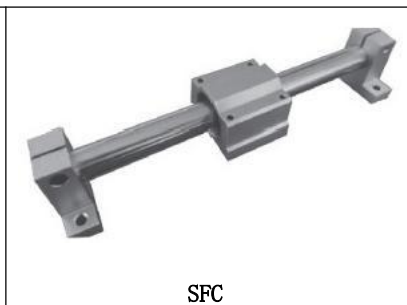

SFC



SFU



GH umano

## NEED HELP?CONTACT US!

Have product questions?Need technical support?Please feel free to contact us:

Technical Support and E-Warranty Certificate [www.vevor.com/support](http://www.vevor.com/support)

Questo è l'istruzione originale, per favore Leggere Tutto manuale istruzioni

attentamente prima di operare.V EVOR si riserva il diritto di interpretazione Di Nostro manuale utente.L'aspetto del prodotto sarà soggetto A IL

prodotto che hai ricevuto. Per favore perdonaci se non lo faremo in forma Voi Ancora Se ce ne sono tecnologia 0 software Aggiornamenti

SU Nostro prodotto.



**WARNING:**

Leggi questo materiale prima utilizzando Questo prodotto. Fallimento A  
Fare COSÌ Potere risultato In serio infortunio.

**SALVA QUESTO MANUALE**

**Precauzioni**

1. Corretto installazione n: Lineare guida rotaie dovere Essere installato correttamente A garantire accurato E liscio movimento. Improprio installazione Potere causa m è allineamento, vincolante, o eccessivo Indossare.

2. Caricare capacità: assicurati di usare un guida lineare rotaia con UN carico capacità Quello È sufficiente per il peso del muoversi parte. Sovraccaricare il guida sbarra Potere causare un'usura eccessiva o danni permanenti .

3. Manutenzione: pulizia regolare E lubrificazione del guida sbarra e scorrevole bloccare Sono importante per mantenere corretta esecuzione ed estensione del servizio vita del guida sbarra.

4. Allineamento: assicurarsi che l' guida lineare sbarra È correttamente allineato e perpendicolarmente alla direzione di marcia per ridurre l'attrito e l'usura.

5. Ambientale condizioni: Guida lineare rotaie Dovrebbe Essere protetto da temperature estreme , umidità, polvere e altro ambientale condizioni Quello Potere simulare prestazione.

6. Protezione da impatto: Guida lineare le rotaie dovrebbero Essere protetto da impatto e altre fonti di shock, poiché possono causa danno a IL sbarra O scorrevole bloccare.

## IMPORTANT SAFETY INFORMATION

7. Ispezione: Regolare ispezione della guida rotaia e scorrevole bloccare È importante identificare e risolvere eventuali problemi o usura prima Essi diventare serio.

## Risoluzione dei problemi

1. Vincolante O attaccamento:Questo Potere perché di disallineamento, funzionamento improprio lubrificazione, o usura eccessiva. Risolvi questo problema,il guida sbarra E scorrevole bloc c o Dovrebbe Essere ispezionato e riallineato se necessario, e lubrificato con il appropriato grasso.

2.Eccessivo indossare:Questo Potere Essere causato di sovraccarico,improprio lubrificazione, o disallineamento. risolvere Questo problema,il carico SU IL guida sbarra Dovrebbe Essere ridotto, e la guida rotaia e scorrevole il blocco dovrebbe Essere ispezionato, riallineato Se necessario e lubrificati con il grasso appropriato.

3. Disallineamento : questo Potere perché di improprio installazione O di Indossare Sopra tempo . A Risolvi questo problema, la guida rotaia e scorrevole il blocco dovrebbe Essere ispezionato E riallineato se necessario.

4. Rumoroso operazione:Questo Potere perché di UN mancanza Di lubrificazione, disallineamento o usura eccessiva. Risolvi questo problema,il guida sbarra E scivolare bloccare Dovrebbe Essere lubrificato con il appropriato grasso, ispezionato E riallineato Se necessario.

5.Ridotto precisione:Questo Potere Essere causato di disallineamento, legatura o eccessivo indossare. Risolvi questo problema,il guida sbarra E scorrevole bloccare Dovrebbe Essere ispezionato, riallineato Se necessario, lubrificato con IL appropriato grasso,e controllato per allineamento corretto.

## PRODUCT SPECIFICATIONS

### SBR GUIDA LINEARE SBARRA

Sbarra Trasporto Blocco (SBRxxUU)

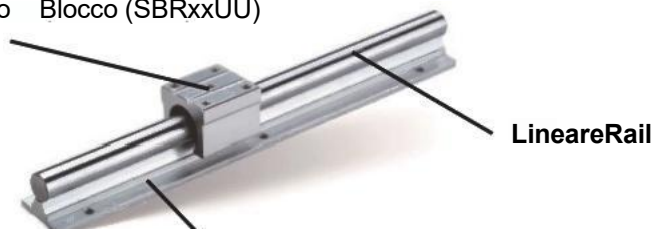

## Lineare Sbarra

- Materiale: GCR15.....45"
- Durezza: HRC62+2(45\*:HRC58)
- Superficie dura-spessore: 0,8~2,5 mm
- Rugosità superficiale: 0,8S~1,6S
- Rettilinearità: 80µm/1000mm
- Rotondità:  $\leq 3,0\mu\text{m}$  (Rmax)



## Carrozza ferroviaria Blocco (SBRxxUU)

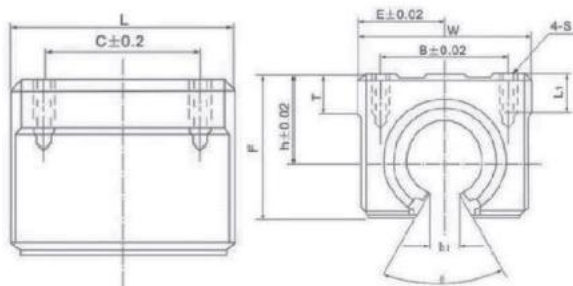

## Supporto ferroviario (SBRxx)

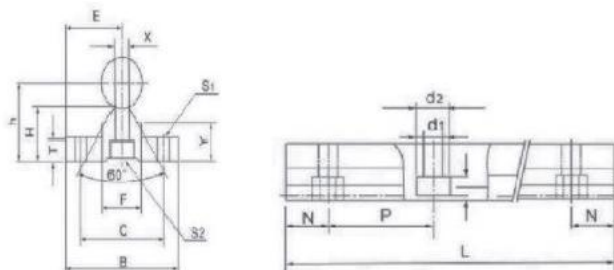

## Modello SBR12-C 1000L

Part e nome	Dimensioni (mm)											
	H	E	L'	L	F	h1	θ	B	C	S	L1	T
Modello SBR12UU	17	20	40	39	27.6	6	80°	28	26	La M5	10	7
Part e nome	Dimensioni (mm)											
	Lancia Dimensioni		E	H	B	H	T	F	X	E	C	S1
SBR12	Dimensioni: 12×1000L		15	22.5	32	16.5	4	12	6	12	22	φ5

## SBR16-C 2000L,1500L,1200L,1000L,800L,600L,500L,400L,300L

Part e nome	Dimensioni (mm)											
	H	E	L'	L	F	h1	θ	B	C	S	L1	T
Modello SBR16UU	20	22.5	45	45	33	10	80°	32	30	La M5	12	9
Part e nome	Dimensioni (mm)											
	Lancia Dimensioni		E	H	B	H	T	F	X	E	C	S1
SBR16	φ16×800L		20	25	40	17.8	5	18.5	8	11.7	30	φ6

## SBR20-C 2200L,1800L,1500L,1200L,1000L,800L,650L,600L,300L

Part e nome	Dimensioni (mm)											
	H	E	L'	L	F	h1	θ	B	C	S	L1	T
Modello SBR20UU	23	24	48	50	39	10	60°	35	35	La M6	12	11
Part e nome	Dimensioni (mm)											
	Lancia Dimensioni		E	H	B	H	T	F	X	E	C	S1
SBR20	φ20×1000L		22.5	27	45	17.7	5	19	8	10	30	φ6

## SBR25-C 1200L

Part e nome	Dimensioni (mm)											
	H	E	L'	L	F	h1	$\theta$	B	C	S	L1	$\tau$
Modello SBR25UU	27	30	60	65	47	11.5	50°	40	40	La M6	12	14
Part e nome	Dimensioni (mm)											
	Lancia Dimensioni	E	H	B	H	T	F	X	E	C	S1	
SBR25	Dimensioni: 25×1200L	27.5	33	55	21	6	21.5	8	12	35	$\Phi 6.5$	

# Specificazione tavolo per palla vite imposta(SFU XX)

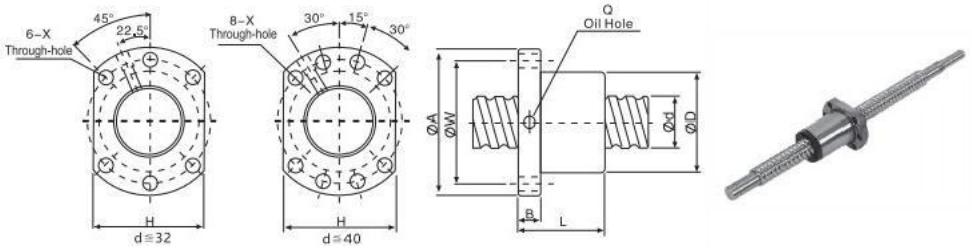

SFU1605-42000L,1700L,1500L,1050L,1000L,700L,650L ,600L,350L

Part e nome	Dimensioni (mm)														
	D	I	Da	D	UN	B	L	L'	X	H	Q	N	Ca	Cer tif ica to di aut ent ici tà	E
SFU1605-4	16	5	3.175	28	48	10	50	38	5.5	40	M6	4	780	1790	20

## SUPPORTO UNITÀ BK

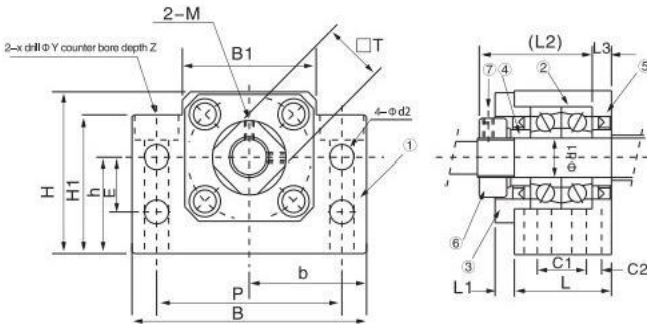

Part e	Lancia diametro n	1	L1	L2	L3	B	H	B		B1	L1	E	P	C1	C2	C3	X	Y	Z	M	T	
								±0,02	±0,02													



## SUPPORTO UNITÀ Ragazzo

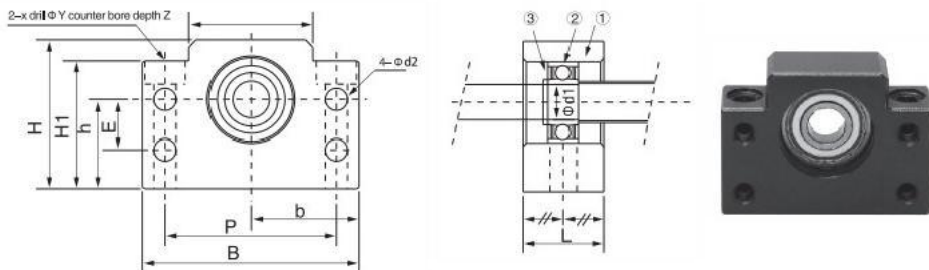

Part e nome	Lancia diametro el ill	L	B	H	B	H	B1	H1	E	P	e2	X	E	La	Cuscine tto	Anello a scatto
					$\pm 0,02$	$\pm 0,02$										
BF-12	12	20	60	43	30	25	35	32.5	18	46	5.5	6.6	10.8	6.5	6000ZZ	S10

## Ragazzo serie Elastico Accoppiamento

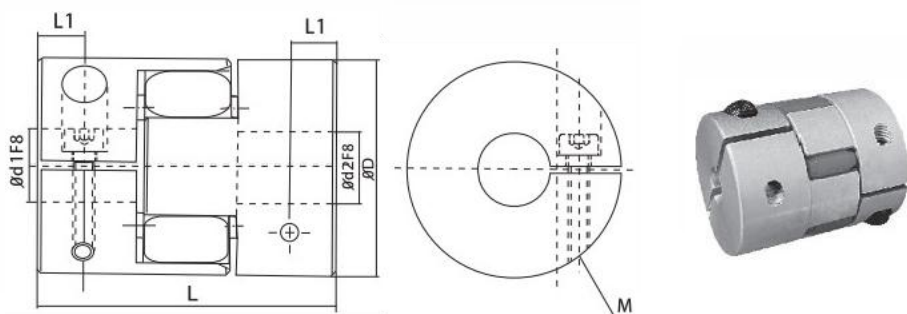

Part e nome	e1 ill Foro	e2 Foro	D	L	L1	M	Valut ato Coppia (Nm)	Massi mo Coppia	Ecce ntricità Errore	Lanci a Angelo	Massimo Rotazionale (giri al minuto)	Valuta to
Ragazzo	5-10	5-10	25	34	5.5	La M3	2N.m	35N • m	$\pm 0,2$ mm	$\leq 1^\circ$	6500	



## DSG1605

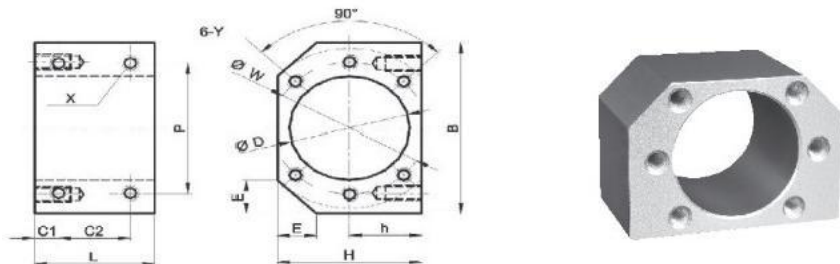

Part e nome	Vite modello	D	B	H	H	E	L	C1	C2	P	X	L'	E
DSG 16 H	1605	28	52	40	20	12	40	8	24	40	La M5	38	La M5

## Dimensioni per la serie HGH Guide lineari

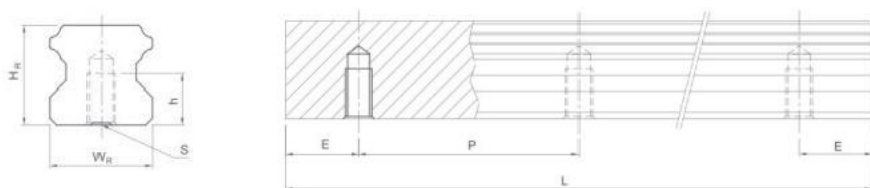

HGH151500L,1200L,300L

HGH202000L,1700L,1500L,1200L,1000L,700L,600L

Part e nome	Dimensioni (mm)						Peso (kg/m)
	L'	H	S	H	P	E	
HGH15	15	15	M5x0.8P	8	60	20	1.48
HGH20	20	17.5	M6x1P	10	60	20	2.29



# HGH-CA SerieLineare Guida cursore Misurare Tavolo

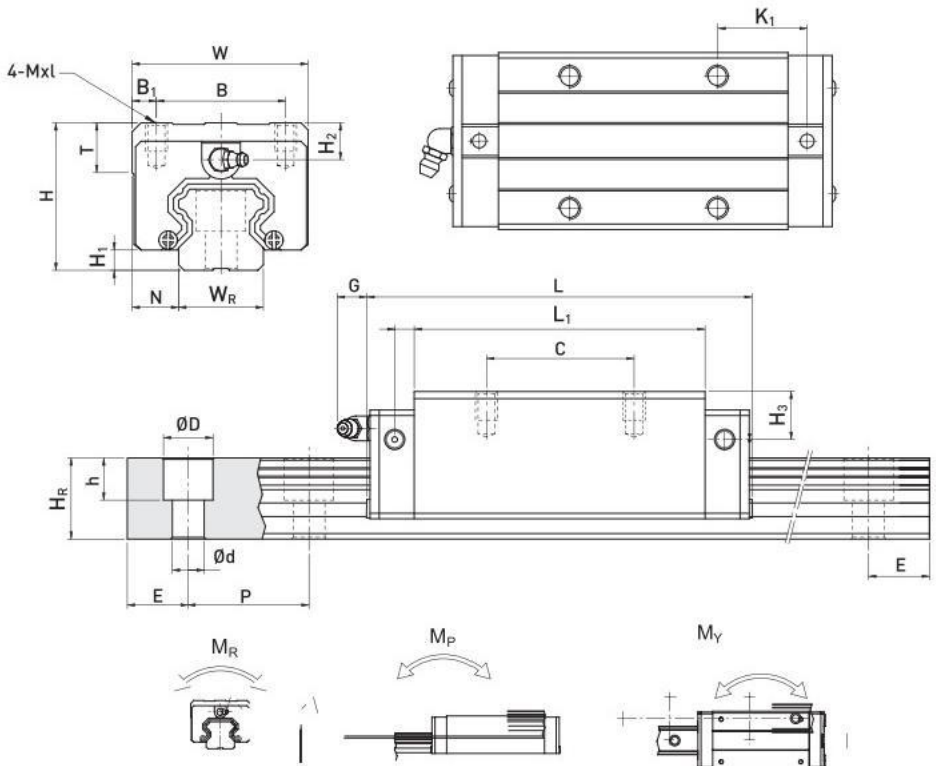

Part e nome	Dimensioni dell'Assemblea (mm)		Dimensioni Di Bloccare (mm)													Dimensioni Di Sbarra (mm)					Montare in g Acquistare per Lamia	Di base Dinamico o Carico Ratto in g	Di base Statico o Carico Valuta zione		
	H	H	N	L'	B	B1	C	L	L	E	G	Mx1	T	L <sub>2</sub>	L <sub>3</sub>	L'	H	D	H	D				P	e
HGH15CA	28	4.3	9.5	34	26	4	26	39.5	60.5	10	5.3	M4x5	6	7.95	7.7	15	15	7.5	5.3	4.5	60	20	M4x16	11.38	16.97
Modello HGH20CA	30	4.6	12	44	32	6	36	50.5	76.7	2.5	12	5x6	8	6	6	20	17.5	9.5	8.5	6	60	20	M5x16	17.75	27.76



## SCORREVOLE LINEARE SBARRA

### Carrozza ferroviaria Blocco (SCS xxUU)

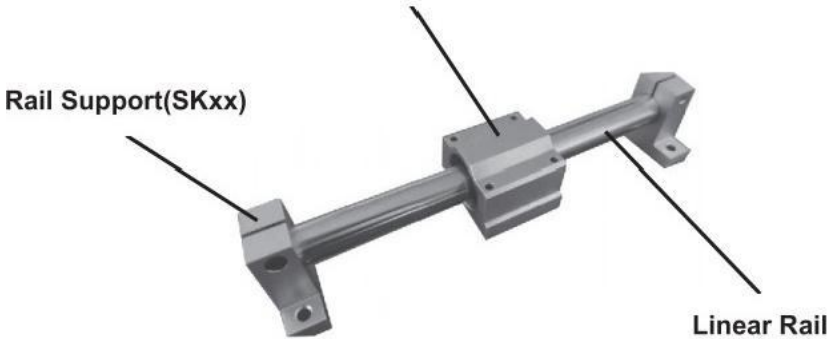

### Lineare Sbarra

- Materiale: GCR15.....45"
- Durezza: HRC62+2(45\*:HRC58)
- Spessore superficie dura: 0,8~2,5 mm
- Rugosità superficiale: 0,8S~1,6S
- Rettilineità: 80 $\mu$ m/1000mm
- Rotondità:  $\leq 3,0\mu$ m (Rmax)



### Carrozza ferroviaria Blocco (SCSxxUU)

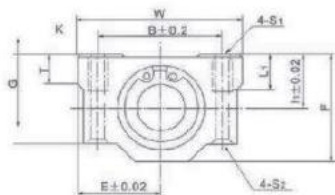
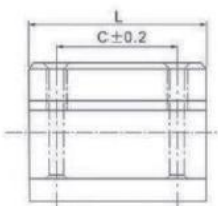

## Supporto ferroviario (SKxx)

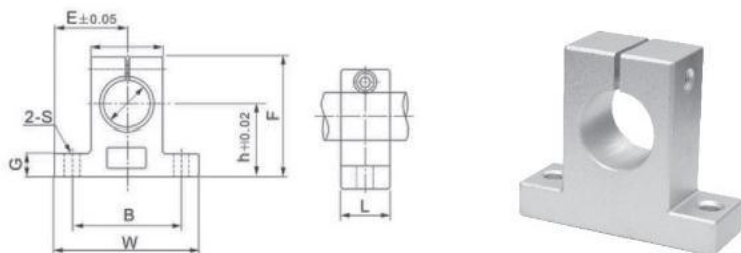

### Modello SFC16-500L

Part e nome	Dimensioni (mm)												
	T	H	E	L'	L	F	G	B	C	E	S1	S2	L1
SCS16UU	9	19	25	50	44	38.5	32.5	36	$\frac{3}{4}$	7	La M5	4.3	12
Part e nome	Dimensioni (mm)												
	Albero Dimensioni			H	E	L'	L	F	G	P	B	S	
SK16	Φ 16×1000L			27	24	48	16	44	8	25	38	5.5	

### Modello SFC16-1000L

Part e nome	Dimensioni (mm)												
	T	H	E	L'	L	F	G	B	C	E	S1	S2	L1
SCS16UU	9	19	25	50	44	38.5	32.5	36	$\frac{3}{4}$	7	La M5	4.3	12
Part e nome	Dimensioni (mm)												
	Albero Dimensioni			H	E	L'	L	F	G	P	B	S	
SK16	Φ 16×1000L			27	24	48	16	44	8	25	38	5.5	

### Modello SFC20-1000L

Part e nome	Dimensioni (mm)												
	T	H	E	L'	L	F	G	B	C	E	S1	S2	L1
SCS20UU	11	21	27	54	50	41	35	40	40	7	La M6	5.2	12
Part e nome	Dimensioni (mm)												
	Albero Dimensioni		H	E	L'	L	F	G	P	B	S		
SK20	Φ 20×1000L		31	30	60	20	51	10	30	45	6.6		

### Modello SFC20-1200L

Part e nome	Dimensioni (mm)												
	T	H	E	L'	L	F	G	B	C	E	S1	S2	L1
SCS20UU	11	21	27	54	50	41	35	40	40	7	La M6	5.2	12
Part e nome	Dimensioni (mm)												
	Shaf Dimensioni		H	E	W	l	F	G	P	B	S		
SK20	Φ 20×1200L		31	30	60	20	51	10	30	45	6.6		

**Produttore:** Shanghaimu xinmuyeyouxiangongsi

**Indirizzo:** Shuangchenglu 803nong11hao1602A-1609shi,baoshanqu,  
shanghai 200000 CN.

**Importato A AUS:** SIHAO PTYLTD, 1 ROKEVASTREETEASTWOOD NSW  
2122 Australia

**Importato A Stati Uniti:** Sanven Tecnologia Società a responsabilità  
limitata, Suite 250,9166 Aniaheim Luogo, Rancho Cucamonga, CA91730

EC	REP
----	-----

E-CrossStu GmbH  
Magonza Strada del paese 69,60329 Francoforte Sono  
Principale.

UK	REP
----	-----

CONSULENZA YH LIMITATO.

Per gentile concessione di YH Consulenza Limitato  
Ufficio 147, Centurione Casa, Strada di Londra,Staines-  
upon-Thames,Surrey, TW184AX

**VEVOR**®

**TOUGH TOOLS, HALF PRICE**

**Supporto tecnico e Certificato di garanzia  
elettronica [www.vevor.com/support](http://www.vevor.com/support)**

# VEVOR®

## TOUGH TOOLS, HALF PRICE

Soporte técnico y Certificado de garantía electrónica  
[www.vevor.com/support](http://www.vevor.com/support)

### GUÍA LINEAL CARRIL

Seguimos comprometidos a brindar tú herramientas con competitivo precio. "Ahorrar Mitad", "Mitad" Precio"o cualquier otro expresiones similares usado por a nosotros solo representa un Estimación de los ahorros que podría obtener al comprar cierto herramientas con a nosotros comparar d a el importante arriba marcas y hace no necesariamente significar cubrir todo Categorías de herramientas Ofrecido por Nosotros.Tu son amable Se le recuerda que debe verificar cuidadosamente cuando son colocación un Ordenar con a nosotros si usted son En realidad, ahorrando la mitad en comparación con el arriba importante marcas.

# VEVOR<sup>®</sup>

TOUGH TOOLS, HALF PRICE

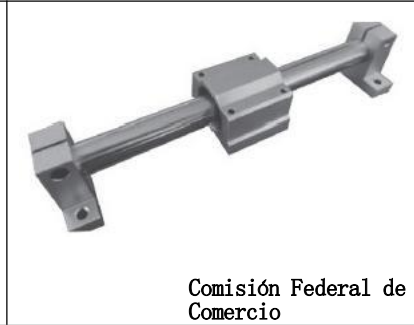

## NEED HELP?CONTACT US!

Have product questions?Need technical support?Please feel free to contact us:

Technical Support and E-Warranty Certificate [www.vevor.com/support](http://www.vevor.com/support)

Este ¿Es la instrucción original, por favor? leer todo manual instrucciones con cuidado antes de operar. EVOR se reserva un derecho de interpretación de nuestro Manual de usuario.La apariencia del producto Será sujeto a el

producto que recibiste. Por favor perdónanos si no podemos ayudarte.  
informar tú de nuevo si hay alguno tecnología o software  
actualizaciones en nuestro producto.

## IMPORTANT SAFETY INFORMATION



### WARNING:

Lea este material antes usando este Producto.Failure a hacer entonces poder resultado en grave lesión.

### AHORRAR ESTE MANUAL

#### Precauciones

- 1.Adecuado Instalación : Lineal guía rieles debe ser instalado adecuadamente a asegurar preciso y liso movimiento.impropio instalación poder causa m desalineación, vinculante,o excesivo tener puesto.
- 2.Carga Capacidad:Asegúrese de utilizar un guía lineal carril con a carga capacidad eso es suficiente para el peso de la moviéndose parte.Sobrecarga de la guía carril poder causar un desgaste excesivo o daño permanente .
3. Mantenimiento: Limpieza periódica. y lubricación del guía carril y deslizándose bloquear son importante para mantener desempeño adecuado y ampliar el servicio La vida de la guía carril.
4. Alineación: Asegúrese de que la guía lineal carril es adecuadamente alineado y perpendicular a la dirección de desplazamiento para reducir la fricción y el desgaste.
5. Medio ambiente Condiciones: Guía lineal rieles debería ser Protegido de temperaturas extremas , humedad, polvo y otro ambiental condiciones eso poder afectar actuación.
6. Protección contra Impacto: Guía lineal Los rieles deberían ser Protegido de impacto y otras fuentes de choque, ya que pueden causa daño a el carril o corredizo bloquear.

## IMPORTANT SAFETY INFORMATION

7. Inspección: Regular Inspección de la guía riel y corredera bloquear es Es importante identificar y abordar cualquier problema o desgaste antes ellos convertirse grave.

## Solución de problemas

1. Encuadernación o pegado: Esto puede ser por desalineación, funcionamiento incorrecto lubricación, o desgaste excesivo. Resuelve este problema, el guía carril y corredizo bloquear debería ser inspeccionado y realineado Si es necesario, y lubricado con el adecuado grasa.

2. Excesivo desgaste: este puede ser causado por sobrecarga, inadecuado lubricación, o Desalineación. resolver este problema, el carga en el guía carril debería ser reducido, y el guía riel y corredera El bloque debería ser inspeccionado, realineado si necesario y lubricado con la grasa adecuada.

3. Desalineación : Esta puede ser por incorrecto instalación o por tener puesto encima tiempo . A Resuelve este problema, la guía riel y corredera El bloque debería ser inspeccionado y realineado si necesario.

4. Ruidoso Operación: Esta puede ser por a falta de lubricación, desalineación o desgaste excesivo. Resuelve este problema, el guía carril y deslizante bloquear debería ser lubricado con el adecuado grasa, inspeccionada y realineado si necesario.

5. Reducido Precisión: Esta puede ser causado por desalineación, atascamiento o excesivo usar. para Resuelve este problema, el guía carril y corredizo bloquear debería ser inspeccionado, realineado si necesario, lubricado con el adecuado grasa, y comprobado para Alineación adecuada.

## PRODUCT SPECIFICATIONS

### SBR GUÍA LINEAL CARRIL

Carril Carro Bloque (SBRxxUU)

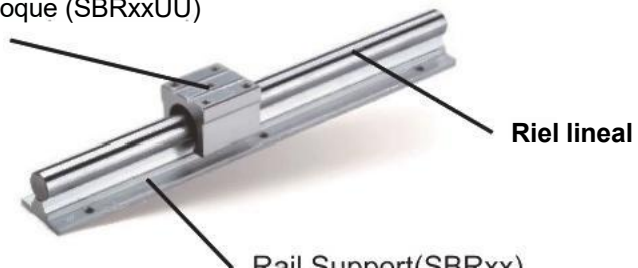

## Lineal Carril

- Material: GCR15.....45"
- Dureza:HRC62+2(45\*:HRC58)
- Superficie dura: espesor: 0,8 ~ 2,5 mm
- Rugosidad de la superficie: 0,8S ~ 1,6S
- Rectitud: 80  $\mu\text{m}/1000\text{ mm}$
- Redondez:  $\leq 3,0\ \mu\text{m}$  (Rmax)



## Vagón de ferrocarril Bloque (SBRxxUU)

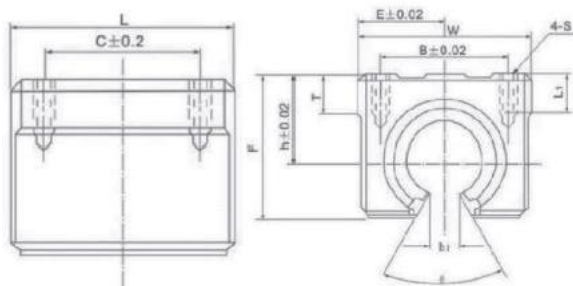

## Soporte ferroviario (SBRxx)

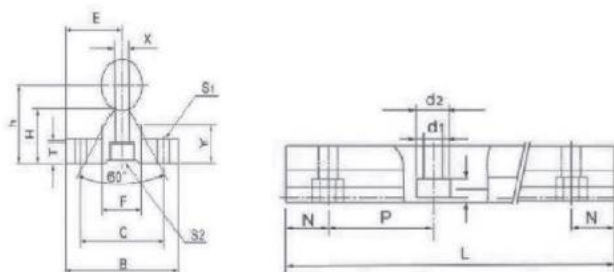

### SBR12-C 1000 litros

Part e nombre	Dimensiones (mm)											
	yo	mi	Yo	yo	F	h1	θ	B	do	S	L1	yo
SBR12UU	17	20	40	39	27.6	6	80°	28	26	M5	10	7
Part e nombre	Dimensiones (mm)											
	Eje Dimensiones		mi	yo	B	yo	yo	F	in cón gñ it a	Y	do	S1
SBR12	Φ12×1000L		15	22.5	32	16.5	4	12	6	12	22	Φ5

### SBR16-C 2000L,1500L,1200L,1000L,800L,600L,500L ,400L,300L

Part e nombre	Dimensiones (mm)											
	yo	mi	Yo	yo	F	h1	θ	B	do	S	L1	yo
SBR16UU	20	22.5	45	45	33	10	80°	32	30	M5	12	9
Part e nombre	Dimensiones (mm)											
	Eje Dimensiones		mi	yo	B	yo	yo	F	in cón gñ it a	Y	do	S1
SBR16	Φ16×800L		20	25	40	17.8	5	18.5	8	11.7	30	Φ6

### SBR20-C 2200L, 1800L, 1500L, 1200L, 1000L, 800L, 650L, 600L, 300L

Part e nombre	Dimensiones (mm)											
	yo	mi	Yo	yo	F	h1	θ	B	do	S	L1	yo
SBR20UU	23	24	48	50	39	10	60°	35	35	M6	12	11
Dimensiones (mm)												

Part e nomb re	Eje Dimensiones	mi	yo	B	yo	yo	F	in c ó gn it a	Y	do	S1
SBR20	$\phi 20 \times 1000L$	22.5	27	45	17.7	5	19	8	10	30	$\phi 6$

## SBR25-C 1200L

Part e nomb re	Dimensiones (mm)											
	yo	mi	Yo	yo	F	hl	θ	B	do	S	L1	yo
SBR25UU	27	30	60	65	47	11.5	50°	40	40	M6	12	14
Part e nomb re	Dimensiones (mm)											
	Eje Dimensiones		mi	yo	B	yo	yo	F	in c ó g n i t a	Y	do	S1
SBR25	Φ25×1200L		27.5	33	55	21	6	21.5	8	12	35	Φ6,5

# Especificación mesa para pelota tornillo conjunto(SFU XX)

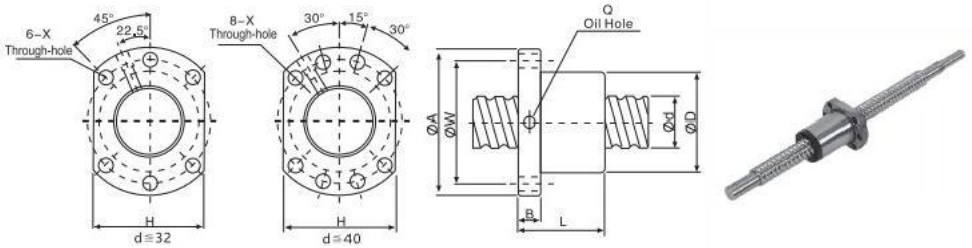

SFU1605-42000L,1700L,1500L,1050L,1000L,700L,650L ,600L,350L

Part e nombre	Dimensiones (mm)														
	d	l	Sf	D	A	B	yo	Yo	in c ó g n i t a	yo	Q	no r t e	Cal ifo r n i a	Coa	K
SFU1605-4	16	5	3.175	28	48	10	50	38	5.5	40	M6	4	780	1790	20

## APOYO UNIDAD bk

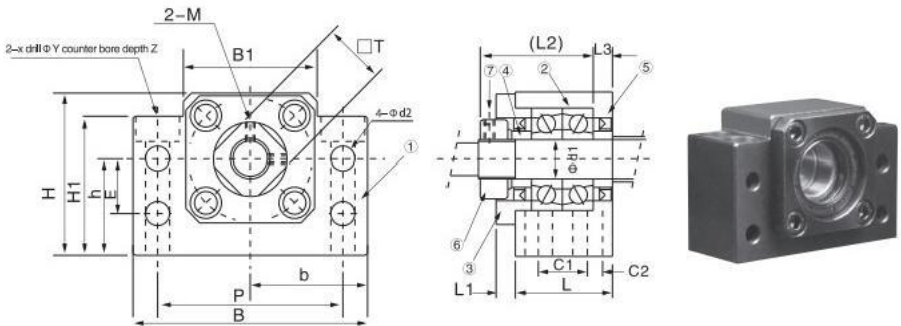

Part e nombre	Eje diámetro sustantivo, masculino	l	L1	L2	L3	B	h	b	h	B1	L1	mi	PA G	C1	C2	C3	in c ó g n i t a	Y	z	ME T R O	t
								±0,02	±0,02												

BK-12	12	25	5	29	5	60	43	30	25	35	32,5	18	46	13	6	5.5	6.5	10.8	6.5	M4	19
-------	----	----	---	----	---	----	----	----	----	----	------	----	----	----	---	-----	-----	------	-----	----	----

-7-

## APOYO UNIDAD BF

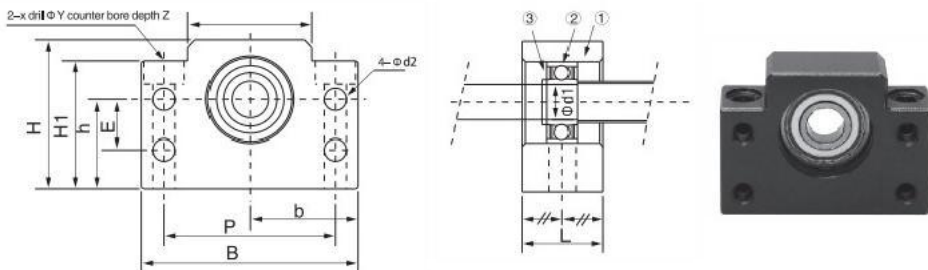

Parte nombre	Eje diámetro d1	yo	B	yo	b	yo	B1	H1	mi	PA G	d2	in cónica	Y	0	Cojinete	Anillo de seguridad
BF-12	12	20	60	43	30	25	35	32.5	18	46	5.5	6.6	10.8	6.5	6000ZZ	S10

## BF serie Elástico Enganche

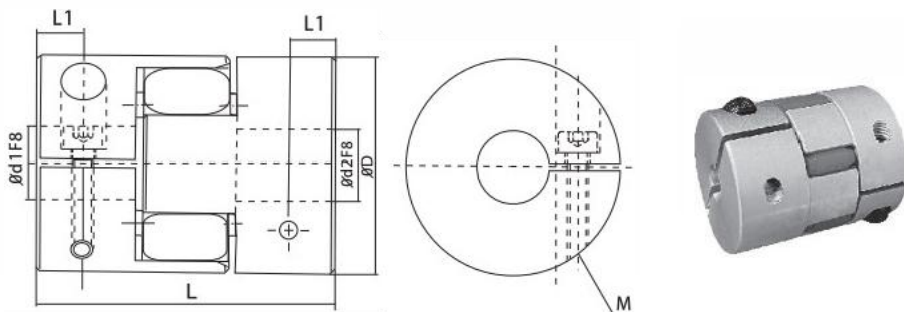

Parte nombre	d1 Aburrir	d2 Aburrir	D	yo	L1	ME TR O	Calificado Esfuerzo de torsión (Nuevo Méjico)	Máx. Esfuerzo de torsión	Excentricidad Error	Eje Ángel	Máx. Rotacional (revoluciones por minuto)	Calificado
BF	5-10	5-10	25	34	5.5	M3	2 N.m	35 N.m	±0,2 mm	≤1°	6500	



## DSG1605

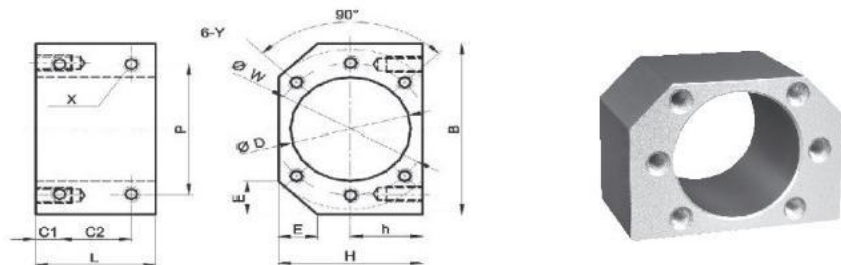

Part e nombre	Tornillo modelo	D	B	yo	yo	mi	yo	C1	C2	PAG	in c ó g n i t a	Yo	Y
DSG 16 yo	1605	28	52	40	20	12	40	8	24	40	M5	38	M5

## Dimensiones de la serie HGH Guías lineales

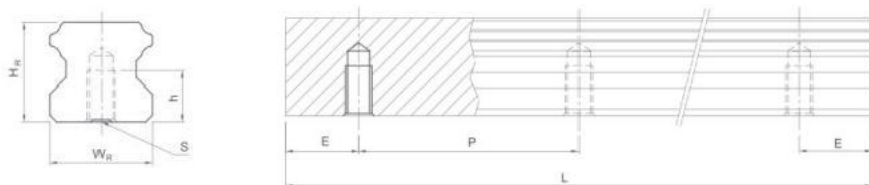

HGH151500L,1200L,300L

HGH202000L,1700L,1500L,1200L ,1000L,700L,600L

Part e nombre	Dimensiones (mm)						Peso
	Yo	yo	S	yo	PAG	mi	(kg/m <sup>3</sup> )
HGH15	15	15	M5x0,8P	8	60	20	1.48

HGH20	20	17.5	M6x1P	10	60	20	2.29
-------	----	------	-------	----	----	----	------

# HGH-CA Serie Lineal Guía Control deslizante Tamaño Mesa

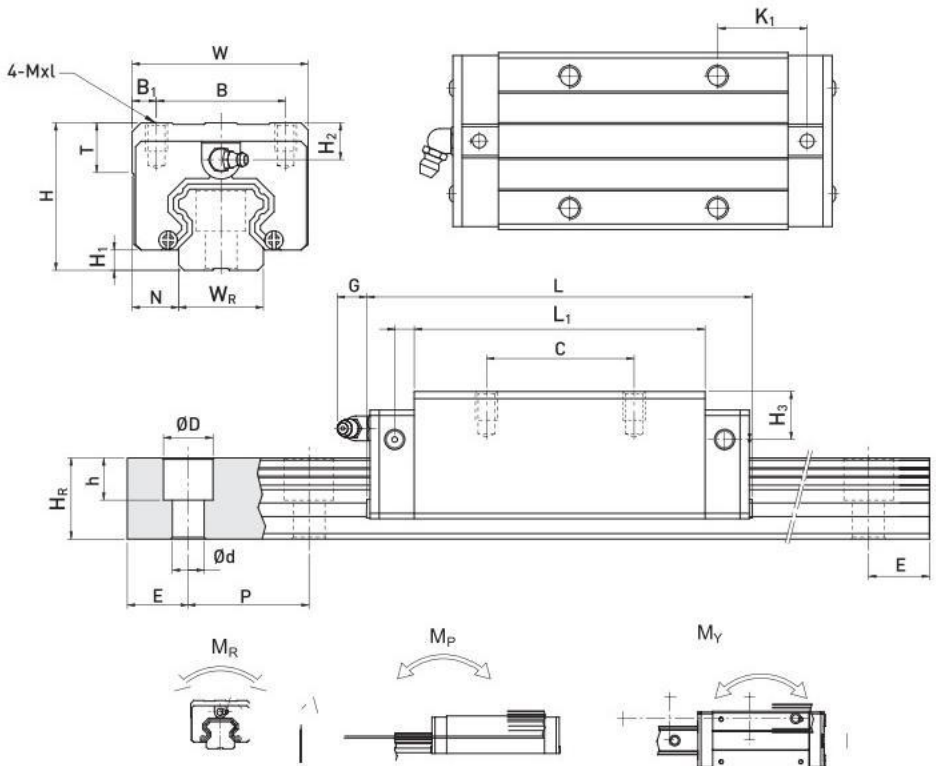

Parte nombre	Dimensiones de la Asamblea (mm)		Dimensiones de Bloquear (mm)													Dimensiones de Carril (mm)					Monte en B oit para Rai	Básico Dinámico Carga en g	Básico Estático Carga Clasificación		
	yo	yo	no	Yo	B	B <sub>1</sub>	do	yo	yo	K	GR	Mx1	yo	H <sub>2</sub>	H <sub>3</sub>	Y	yo	D	h	d				PA	mi
HGH15CA	28	4.3	9.5	34	26	4	26	39.5	60.5	10	5.3	M4x5	6	7.9	7.7	15	15	7.5	5.3	4.5	60	20	M4x16	11,38	16,97
HGH20CA	30	4.6	12	44	32	6	36	50.5	76.7	2.2	12	M5x6	8	6	6	20	17.5	9.5	8.5	6	60	20	M5x16	17,75	27,76



## DESLIZAMIENTO LINEAL CARRIL

### Vagón de ferrocarril Bloque (SCS xxUU)



### Lineal Carril

- Material: GCR15.....45"
- Dureza:HRC62+2(45\*:HRC58)
- Superficie dura: espesor: 0,8 ~ 2,5 mm ●Rugosidad de la superficie: 0,8S ~ 1,6S
- Rectitud: 80  $\mu$ m/1000 mm
- Redondez:  $\leq 3,0 \mu$ m (Rmax)



### Vagón de ferrocarril Bloque (SCSxxUU)

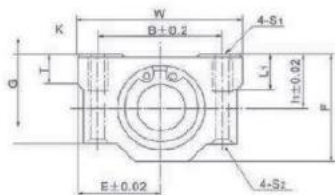
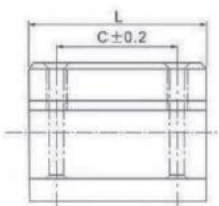

## Soporte ferroviario (SKxx)

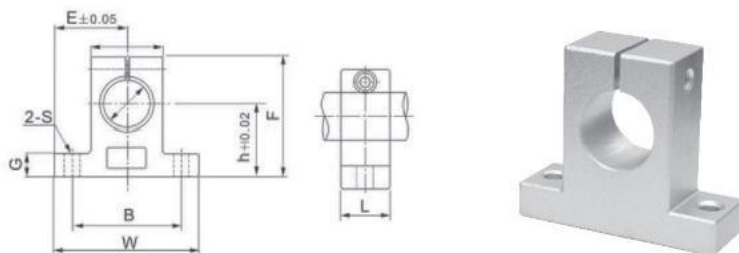

### SFC16-500L

Part e nomb re	Dimensiones (mm)												
	yo	yo	mi	Yo	yo	F	GRA MO	B	do	K	S1	S2	L1
SCS16UU	9	19	25	50	44	38.5	32.5	36	$\frac{3}{4}$	7	M5	4.3	12
Part e nomb re	Dimensiones (mm)												
	Eje Dimensiones		yo	mi	Yo	yo	F	GRA MO	PAG	B	S		
SK16	φ 16×1000L		27	24	48	16	44	8	25	38	5.5		

### SFC16-1000L

Part e nomb re	Dimensiones (mm)												
	yo	yo	mi	Yo	yo	F	GRA MO	B	do	K	S1	S2	L1
SCS16UU	9	19	25	50	44	38.5	32.5	36	$\frac{3}{4}$	7	M5	4.3	12
Part e nomb re	Dimensiones (mm)												
	Eje Dimensiones		yo	mi	Yo	yo	F	GRA MO	PAG	B	S		
SK16	φ 16×1000L		27	24	48	16	44	8	25	38	5.5		

### SFC20-1000L

Part e nomb re	Dimensiones (mm)												
	yo	yo	mi	Yo	yo	F	GRA MO	B	do	K	S1	S2	L1
SCS20UU	11	21	27	54	50	41	35	40	40	7	M6	5.2	12
Part e nomb re	Dimensiones (mm)												
	Eje Dimensiones		yo	mi	Yo	yo	F	GRA MO	PA G	B	S		
SK20	Φ20×1000L		31	30	60	20	51	10	30	45	6.6		

### SFC20-1200L

Part e nomb re	Dimensiones (mm)												
	yo	yo	mi	Yo	yo	F	GRA MO	B	do	K	S1	S2	L1
SCS20UU	11	21	27	54	50	41	35	40	40	7	M6	5.2	12
Part e nomb re	Dimensiones (mm)												
	shaf Dimensiones		h	mi	W.	l	F	GRA MO	PA G	B	S		
SK20	Φ20×1200L		31	30	60	20	51	10	30	45	6.6		

**Fabricante:** Shanghaimu xinmuyeyouxiangongsi

**DIRECCIÓN:** Shuangchenglu 803nong11hao1602A-1609shi,baoshanqu, shanghai 200000 CN.

**Importado a AUS:** SIHAO PTYLTD, 1 ROKEVASTREET, EASTWOOD, NUEVA GALES DEL SUR 2122 Australia

**Importado a Estados Unidos:** Sanven Tecnología Limitada., Suite 250,9166 Anaheim Lugar, Rancho Cucamonga, CA91730

EC	REP
----	-----

E-CrossStu GmbH  
Maguncia Calle del País 69,60329 Fráncfort soy  
Principal.

UK	REP
----	-----

CONSULTORÍA YH LIMITADO.  
Atención al cliente YH Consultante Limitado Oficina  
147,Centurión Casa, Carretera de Londres, Staines-  
upon-Thames, Surrey, TW184AX

**VEVOR<sup>®</sup>**

**TOUGH TOOLS, HALF PRICE**

**Soporte técnico y Certificado de garantía  
electrónica [www.vevor.com/support](http://www.vevor.com/support)**

# VEVOR®

## TOUGH TOOLS, HALF PRICE

Wsparcie techniczne i Certyfikat E-Gwarancji [www.vevor.com/support](http://www.vevor.com/support)

### PROWADNICA LINIOWA KOLEJ

Nadal jesteśmy zaangażowani w zapewnianie Ty narzędzia z konkurencyjny  
cena.

"Ratować Połowa", "Połowa Cena" lub każdy Inny podobne wyrażenia używany przez  
nas tylko reprezentuje jakiś  
szacunkowe oszczędności, jakie możesz uzyskać kupując niektóre narzędzia z nas  
porównaj do ten główny  
szczyt marki i robi nie koniecznie oznaczać pokryć wszystkie kategorie narzędzi  
oferowany przez nas. Ty  
Czy uprzejmie przypominałem, aby dokładnie sprawdzić, kiedy Czy umieszczanie jakiś  
zamów z nas jeśli ty Czy  
faktycznie oszczędzają W porównanie z ten szczyt główny marki.

# VEVOR®

TOUGH TOOLS, HALF PRICE



SBR

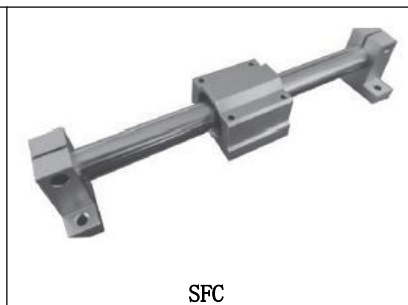

SFC



SFU



hormon wzrostu

## NEED HELP?CONTACT US!

Have product questions?Need technical support?Please feel free to contact us:

Technical Support and E-Warranty Certificate [www.vevor.com/support](http://www.vevor.com/support)

Ten to jest oryginalna instrukcja, proszę Czytać Wszystko podręcznik instrukcje przed rozpoczęciem użytkowania należy zachować ostrożność. V EVOR zastrzega sobie wyraźne interpretacja z nasz instrukcja obsługi.Wygląd produktu będzie temat Do ten produktu, który otrzymałeś. Przepraszamy, że nie będziemy mogli formalnie Ty Ponownie Jeśli są jakieś technologia Lub oprogramowanie

Aktualizacje NA nasz produkt.



### WARNING:

Przeczytaj ten materiał przed używając Ten Produkt. Błąd Do Do Więcej  
Móc wynik W poważny obrażenia.

## RATOWAĆ TEN PODRĘCZNIK

### Środki ostrożności

1. Właściwy instalacja :Liniowa przewodnik szyny musieć Być zainstalowany odpowiednio Do zapewnić dokładny I gładki ruch. Niewłaściwy instalacja Móc przyczyna niewspółosiowość , wiążący, lub nadmierny nosić.
2. Załaduj pojemność: Upewnij się, że użyj prowadnica liniowa szyna z A obciążenie pojemność To Jest wystarczający do udźwignięcia ciężaru poruszający część. Przeciążenie przewodnik kolej Móc powodować nadmierne zużycie lub trwałe uszkodzenie.
3. Konserwacja: Regularne czyszczenie I smarowanie z przewodnik kolej i ślizganie blok Czy ważne dla utrzymywać prawidłowe wykonanie i przedłużenie usługi życie przewodnik kolej.
4. Wyrównanie: Upewnij się, że prowadnica liniowa kolej Jest odpowiednio wyrównany i prostopadle do kierunku jazdy, aby zmniejszyć tarcie i zużycie.
5. Środowisko warunki: Prowadnica liniowa szyny powinien Być chroniony przed ekstremalne temperatury, wilgoć, kurz i Inny środowiskowy warunki To Móc oddziaływać wydajność.
6. Ochrona przed uderzenie: przewodnik liniowy szyny powinny Być chroniony przed uderzenia i inne źródła wstrząsów, ponieważ mogą one przyczyna uszkodzenie ten kolej Lub przesuwny blok.

## IMPORTANT SAFETY INFORMATION

---

7. Kontrola: Regularna kontrola przewodnika szyna i zjeżdżalnia blok Jest ważne jest, aby zidentyfikować i rozwiązać wszelkie problemy lub zużycie przed Oni stać się poważny.

## Rozwiązywanie problemów

1. Wiązanie Lub przyklejanie: To Móc bod przez rozbieżność, działanie impr smarowanie, lub nadmierne zużycie. Do rozwiąż to problem, ten przewodnik kolej I przesuwny blok powinien Być skontrolowano i wyrównany jeśli to konieczne, i nasmarowany odpowiedni smar.

2. Nadmierny nosić: To Móc Być spowodowany przez przeciążenie, niewłaściwe smarowanie, lub niezgodność. Do rozstrzygać Ten problem, ten obciążenie NA ten przewodnik kolej powinien Być zmniejszony, i przewodnik szyna i zjeżdżalnia blok powinien Być skontrolowano, ponownie ustawiono Jeśli konieczne i nasmarowane odpowiednim smarem.

3. Niewspółosiowość : To Móc bod przez niewłaściwy instalacja Lub przez nosić nad czas . Do rozwiąż to problem, przewodnik szyna i zjeżdżalnia blok powinien Być skontrolowany I wyrównany ponownie, jeśli niezbędny.

4. Hałaśliwy operacja: To Móc bod przez A brak z smarowanie, niewspółosiowość lub nadmierne zużycie. Do rozwiąż to problem, ten przewodnik kolej I ślizganie się blok powinien Być nasmarowany odpowiedni smar, sprawdzony I wyrównany Jeśli niezbędny.

5. Zredukowany dokładność: To Móc Być spowodowany przez niewspółosiowość, wiązanie lub nadmierny nosić. Do rozwiąż to problem, ten przewodnik kolej I przesuwny blok powinien Być skontrolowano, ponownie wyrównano Jeśli konieczne, smarowane ten odpowiedni smar i sprawdzony Do właściwe ustawienie.

## PRODUCT SPECIFICATIONS

### SBR PROWADNICA LINIOWA KOLEJ

Kolej Przewóz Blok (SBRxxUU)





## Liniowy Kolej

- Materiał: GCR15.....45"
- Twardość: HRC62+2(45\*:HRC58)
- Powierzchnia twarda - grubość:  
0,8~2,5 mm
- Chropowatość powierzchni: 0,8S~1,6S
- Prostoliniowość:

80µm/1000mm ●Okrągłość:

≤3,0 µm (Rmax)



## Wagon kolejowy Blok (SBRxxUU)

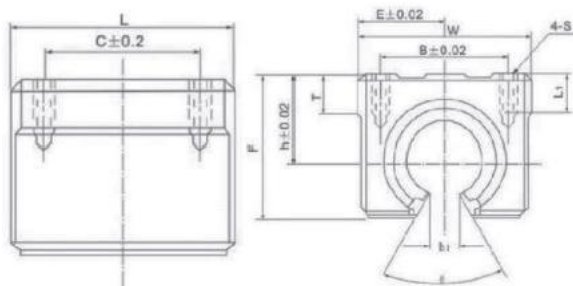

## Wsparcie kolei (SBRxx)

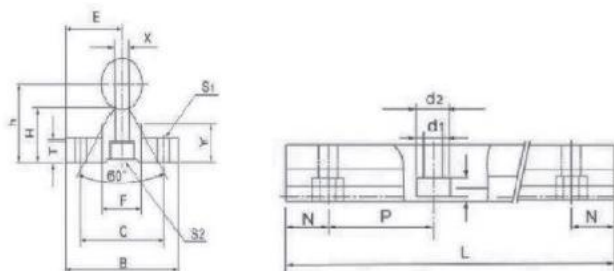

## SBR12-C 1000L

Część nazwa	Wymiary (mm)											
	H	mi	W	L	F	h1	θ	B	C	S	L1	T
SBR12UU	17	20	40	39	27.6	6	80°	28	26	M5	10	7
Część nazwa	Wymiary (mm)											
	Wał Wymiary		mi	H	B	H	T	F	X	Tak	C	S1
SBR12	Φ12×1000L		15	22,5	32	16,5	4	12	6	12	22	Φ5

## SBR16-C 2000L, 1500L, 1200L, 1000L, 800L, 600L, 500L, 400L, 300L

Część nazwa	Wymiary (mm)											
	H	mi	W	L	F	h1	θ	B	C	S	L1	T
SBR16UU	20	22,5	45	45	33	10	80°	32	30	M5	12	9
Część nazwa	Wymiary (mm)											
	Wał Wymiary		mi	H	B	H	T	F	X	Tak	C	S1
SBR16	Φ16×800L		20	25	40	17.8	5	18,5	8	11.7	30	Φ6

## SBR20-C 2200L, 1800L, 1500L, 1200L, 1000L, 800L, 600L, 500L, 300L

Część nazwa	Wymiary (mm)											
	H	mi	W	L	F	h1	θ	B	C	S	L1	T
SBR20UU	23	24	48	50	39	10	60°	35	35	M6	12	11
Część nazwa	Wymiary (mm)											
	Wał Wymiary		mi	H	B	H	T	F	X	Tak	C	S1

SBR20	$\phi 20 \times 1000L$	22, 5	27	45	17.7	5	19	8	10	30	$\phi 6$
-------	------------------------	-------	----	----	------	---	----	---	----	----	----------

## SBR25-C 1200L

Część nazwa	Wymiary (mm)											
	H	mi	W	L	F	h1	θ	B	C	S	L1	τ
SBR25UU	27	30	60	65	47	11.5	50°	40	40	M6	12	14
Część nazwa	Wymiary (mm)											
	Wał Wymiary		mi	H	B	H	T	F	X	Tak	C	S1
SBR25	Φ25×1200L		27,5	33	55	21	6	21,5	8	12	35	Φ6,5

## Specyfikacja tabela Do piłka śruba zestaw(SFU XX)

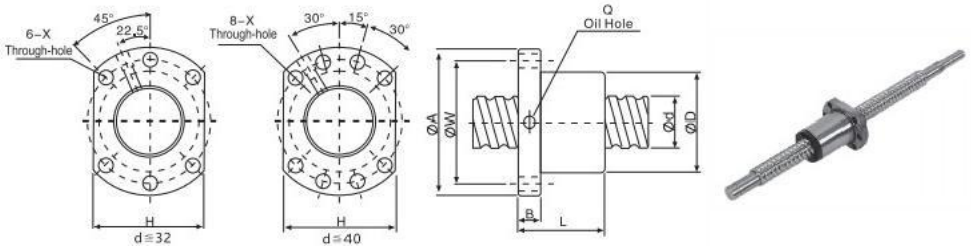

SFU1605-42000L, 1700L, 1500L, 1050L, 1000L, 700L, 650L, 600L, 350L

Część nazwa	Wymiary (mm)														
	D	I	Tak	D	A	B	L	W	X	H	Q	N	Ca	Coa	K
SFU1605-4	16	5	3.175	28	48	10	50	38	5.5	40	M6	4	780	1790	20

## WSPARCIE JEDNOSTKA BK

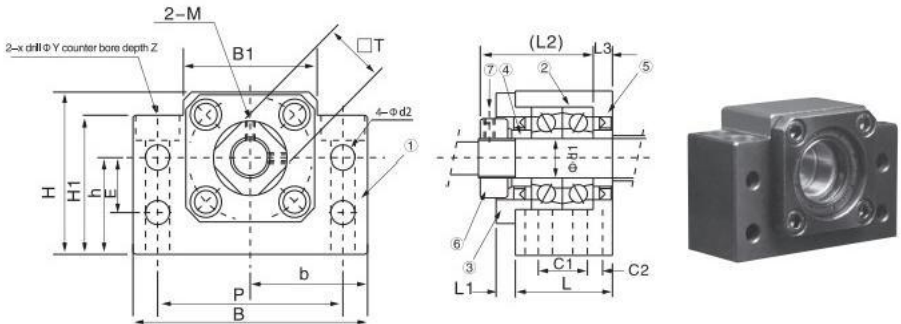

Część nazwa	Walec średnica rz d1	L	L1	L2	L3	B	H	B	H	B1	L1	mi	P	C1	C2	C3	X	Y	Z	M	T
								±0,02	±0,02												
BK-12	12	25	5	29	5	60	43	30	25	35	32,5	18	46	13	6	5.5	6,5	10.8	6,5	M4	19



## WSPARCIE JEDNOSTKA BF

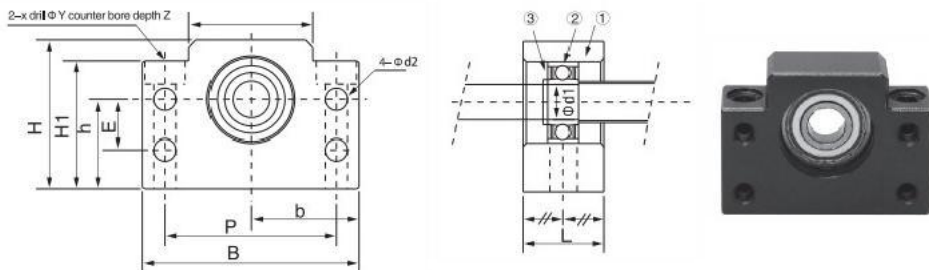

Część nazwa	Wał średnica d1	L	B	H	B	H	B1	H1	mi	P	d2	X	Tak	Z	Łożysko	Pierścienie zatraskowy
					$\pm 0,02$	$\pm 0,02$										
BF-12	12	20	60	43	30	25	35	32,5	18	46	5.5	6.6	10.8	6,5	6000ZZ	S10

## BF szereg Elastyczny Sprzęganie

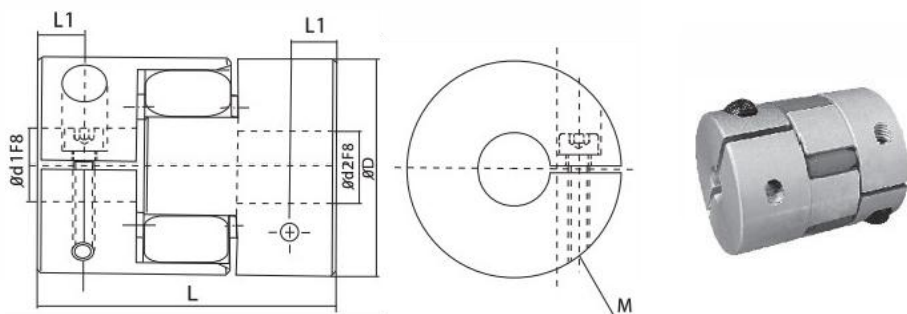

Część nazwa	d1 Nudz iarz	d2 Nudz iarz	D	L	L1	M	Oceni ony Moment obrotowy (Nm)	Maks. Moment obrotowy	Ekscentryczn ość Błąd	Wał Anioł	Maks. Rotacyjny (obr./mi n)	Oceni ony
BF	5-10	5-10	25	34	5.5	M3	2Nm	35Nm	$\pm 0,2$ mm	$\leq 1^\circ$	6500	



## DSG1605

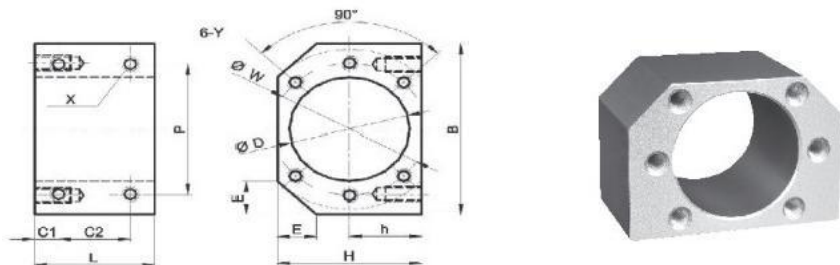

Część nazwa	Śruba model	D	B	H	H	mi	L	C1	C2	P	X	W	Tak
DSG 16 H	1605	28	52	40	20	12	40	8	24	40	M5	38	M5

## Wymiary dla serii HGH Prowadnice liniowe

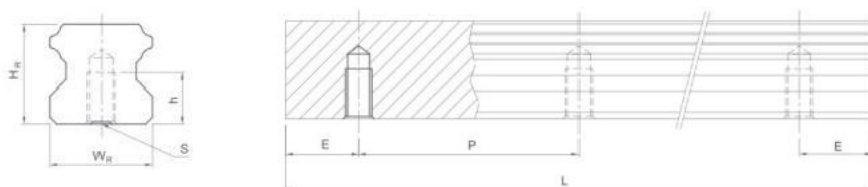

HGH151500L,1200L,300L

HGH202000L, 1700L, 1500L, 1200L , 1000L, 700L, 600L

Część nazwa	Wymiary (mm)						Waga
	W	H	S	H	P	mi	(kg/m3)
HGH15	15	15	M5x0,8P	8	60	20	1,48

HGH20	20	17,5	M6x1P	10	60	20	2.29
-------	----	------	-------	----	----	----	------

# HGH-CA Seria Liniowa Przewodnik Suwak Rozmiar Tabela

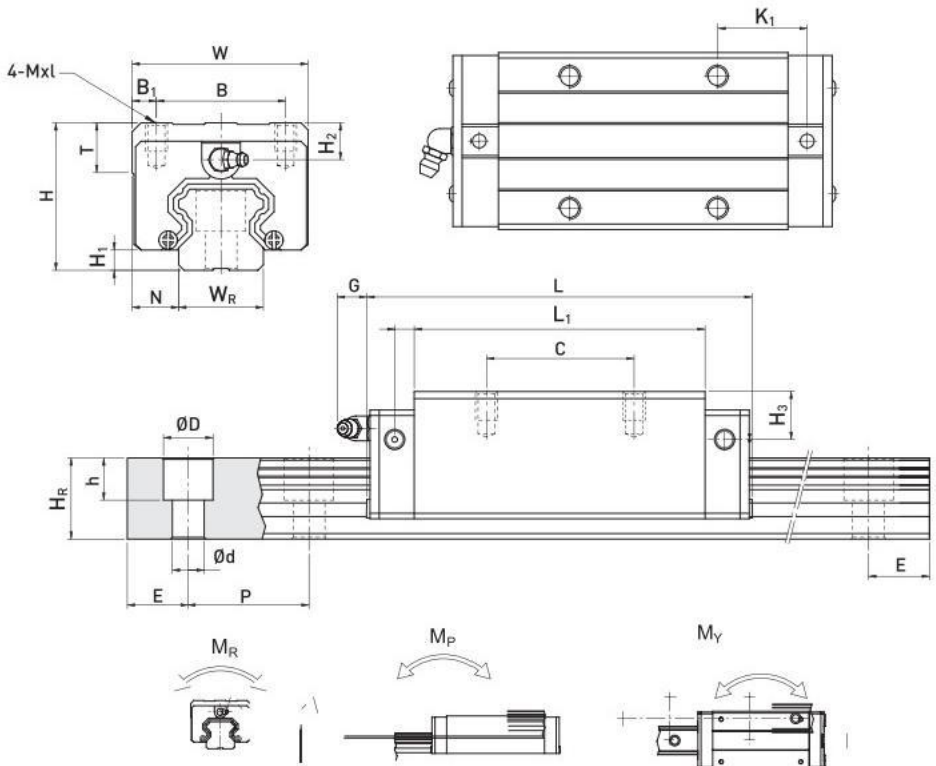

Część nazwa	Wymiary Zgromadzenia (mm)			Wymiary z Blok (mm)										Wymiary z Kolej										Mocowanie Boido Rai	Podstawowy Obciążenie Szczurwgramach	Podstawowy Statyczny Obciążenie Ocena
	H	H	N	W	B	B1	C	L	L	K	G	Mx1	T	H2	H3	W	H	D	H	D	P	mi	mm			
HGH15CA	28	4.3	9.5	34	26	4	26	39.5	60.5	10	5.3	M4x5	6	7.9	7.7	15	15	7.5	5.3	4.5	60	20	M4x16	11,38	16,97	
HGH20CA	30	4.6	12	44	32	6	36	50.5	72.2	12	5.3	M5x6	8	6	6	20	17.5	9.5	8.5	6	60	20	M5x16	17,75	27,76	



## SUWAK LINIOWY KOLEJ

### Wagon kolejowy Blok (SCS xxUU)



### Liniowy Kolej

- Materiał: GCR15.....45"
- Twardość: HRC62+2(45\*:HRC58)
- Twardość powierzchni - grubość: 0,8~2,5 mm •Chropowatość powierzchni: 0,8S~1,6S
- Prostoliniowość: 80 $\mu$ m/1000mm •Okrągłość:  $\leq 3,0 \mu$ m (Rmax)



### Wagon kolejowy Blok (SCSxxUU)

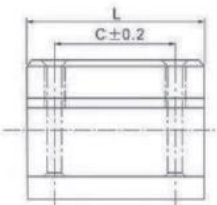

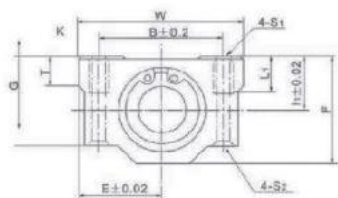

## Wsparcie kolejowe (SKxx)

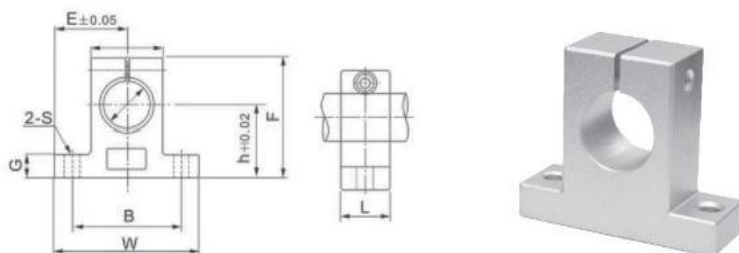

### SFC16-500L

Część śc nazwa	Wymiary (mm)												
	T	H	mi	W	L	F	G	B	C	K	S1	S2	L1
SCS16UU	9	19	25	50	44	38,5	32,5	36	3 4	7	M5	4.3	12
Część śc nazwa	Wymiary (mm)												
	Wał Wymiary			H	mi	W	L	F	G	P	B	S	
SK16	φ 16×1000L			27	24	48	16	44	8	25	38	5.5	

### SFC16-1000L

Część śc nazwa	Wymiary (mm)												
	T	H	mi	W	L	F	G	B	C	K	S1	S2	L1
SCS16UU	9	19	25	50	44	38,5	32,5	36	3 4	7	M5	4.3	12
Część śc nazwa	Wymiary (mm)												
	Wał Wymiary			H	mi	W	L	F	G	P	B	S	
SK16	φ 16×1000L			27	24	48	16	44	8	25	38	5.5	

## SFC20-1000L

Część nazwa	Wymiary (mm)												
	T	H	mi	W	L	F	G	B	C	K	S1	S2	L1
SCS20UU	11	21	27	54	50	41	35	40	40	7	M6	5.2	12
Część nazwa	Wymiary (mm)												
	Wał Wymiary		H	mi	W	L	F	G	P	B	S		
SK20	Φ20×1000L		31	30	60	20	51	10	30	45	6.6		

## SFC20-1200L

Część nazwa	Wymiary (mm)												
	T	H	mi	W	L	F	G	B	C	K	S1	S2	L1
SCS20UU	11	21	27	54	50	41	35	40	40	7	M6	5.2	12
Część nazwa	Wymiary (mm)												
	Shaf Wymiary		H	mi	W	L	F	G	P	B	S		
SK20	Φ20×1200L		31	30	60	20	51	10	30	45	6.6		

**Producent:** Shanghaimu xinmuyeyouxiangongsi

**Adres:** Shuangchenglu 803nong11hao1602A-1609shi,baoshanqu,  
szanghaj 200000 CN.

**Importowany Do AUS:** SIHAO PTYLTD, 1 ROKEVASTREETEASTWOOD  
NSW 2122 Australia

**Importowany Do Stany Zjednoczone:** Sanven Technologia Sp. z  
o.o., Suite 250, 9166 Anaheim Miejsce, Rancho Cucamonga, CA91730

EC	REP
----	-----

E-CrossStu GmbH  
Mainzer Droga krajowa 69, 60329 Frankfurt jestem  
Główny.

UK	REP
----	-----

KONSULTACJE YH OGRANICZONY.  
C/O YH Ordynacyjny Ograniczony Biuro 147, Centurion  
Dom, London Road, Staines-upon-Thames, Surrey,  
TW184AX

**VEVOR**<sup>®</sup>

**TOUGH TOOLS, HALF PRICE**

**Wsparcie techniczne i Certyfikat gwarancji  
elektronicznej [www.vevor.com/support](http://www.vevor.com/support)**

# VEVOR®

## TOUGH TOOLS, HALF PRICE

Technische ondersteuning en E-garantiecertificaat  
[www.vevor.com/support](http://www.vevor.com/support)

### LINEAIRE GELEIDING SPOOR

Wij blijven ons inzetten om Jij gereedschap met competitief prijs.  
"Redden Halve, halve Prijs" of elk ander soortgelijke uitdrukkingen gebruikt door ons  
alleen vertegenwoordigt een  
schatting van de besparingen die u kunt behalen door te kopen zeker hulpmiddelen met  
ons vergelijk d naar de belangrijk  
bovenkant merken En doet niet noodzakelijkerwijs bedoelen met alles bedekken  
categorieën van gereedschappen aangeboden door wij, jij  
Zijn vriendelijk herinnerd om zorgvuldig te controleren wanneer u Zijn plaatsen een  
bestellen met ons als jij Zijn  
eigenlijk de helft besparen in vergelijking met de bovenkant belangrijk  
merken.

# VEVOR<sup>®</sup>

TOUGH TOOLS, HALF PRICE



SBR

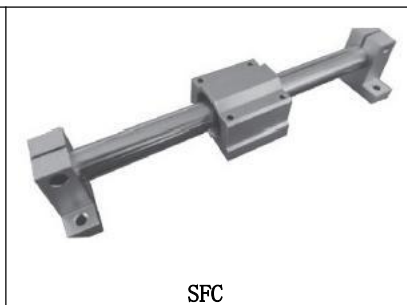

SFC



SFU



HGH

## NEED HELP?CONTACT US!

Have product questions?Need technical support?Please feel free to contact us:

Technical Support and E-Warranty Certificate [www.vevor.com/support](http://www.vevor.com/support)

Dit is de originele instructie, alstublieft lezen alle handmatig instructies

zorgvuldig voordat u gaat werken. VEVOR behoudt zich een duidelijk interpretatie van ons gebruiksaanwijzing. Het uiterlijk van het product zal zijn onderwerp naar de product dat u hebt ontvangen. Vergeef ons dat we niet zullen in vorm Jij opnieuw als er zijn er technologie of software bijgewerkt op ons

product.



### WARNING:

Lees dit materiaal voordat u gebruik makend van dit product. Failure naar  
Doen Dus kan resultaat in serieuze blessure.

### REDDEN DIT HANDMATIG

#### Voorzorgsmaatregelen

1. Juiste installatie: Lineaire gids rails moeten zijn geïnstalleerd op de juiste manier naar ervoor zorgen nauwkeurig En zacht beweging. Onjuist installatie kan oorzaak misalignment, bindend, of excessief dragen.
2. Laden capaciteit: Zorg ervoor dat gebruik een lineaire geleider spoor met A laden capaciteit Dat is voldoende voor het gewicht van de bewegende onderdeel. Overbelasting van de gids spoor kan overmatige slijtage veroorzaken of blijvende schade.
3. Onderhoud: Regelmatig schoonmaken En smering van de gids spoor en glijden blok Zijn belangrijk voor behouden goede uitvoering en verlenging van de service leven van de gids spoor.
4. Uitlijning: Zorg ervoor dat de lineaire geleider spoor is op de juiste manier uitgelijnd en loodrecht op de rijrichting om wrijving en slijtage te verminderen.
5. Milieu voorwaarden: Lineaire geleiding rails zou moeten zijn beschermd tegen extreme temperaturen, vocht, stof en andere milieu voorwaarden Dat kan beïnvloeden prestatie.
6. Bescherming tegen impact: Lineaire geleiding rails zouden moeten zijn beschermd tegen impact en andere bronnen van schok, omdat deze kunnen oorzaak schade aan de spoor of glijden blok.

## **IMPORTANT SAFETY INFORMATION**

7. Inspectie: Regelmatig inspectie van de gids rail en glijden blok is belangrijk om eventuele problemen of slijtage te identificeren en aan te pakken voordat u zij worden serieus.

## Probleemoplossing

1. Bindend of plakken: Dit kan omdat door verkeerde uitlijning, onjuiste smering, of overmatige slijtage. Om dit oplossen kwestie, de gids spoor En glijden blok zou moeten zijn

geïnspecteerd en opnieuw uitgelijnd indien nodig, en gesmeerd met de gepast vet.

2. Overmatig dragen: Dit kan zijn veroorzaakt door overbelasting, onjuist smering, of verkeerde uitlijning. Om oplossen dit kwestie, de laden op de gids spoor zou moeten zijn verminderd, en de gids rail en glijden blok zou moeten zijn geïnspecteerd, opnieuw uitgelijnd als indien nodig, en gesmeerd met het juiste vet.

3. Verkeerde uitlijning : Dit kan omdat door ongepast installatie of door dragen over tijd . Naar dit oplossen kwestie, de gids rail en glijden blok zou moeten zijn geïnspecteerd En opnieuw uitgelijnd als nodig.

4. Ruisachtig operatie: Dit kan omdat door A gebrek van smering, verkeerde uitlijning of overmatige slijtage. Om dit oplossen kwestie, de gids spoor En glijden blok zou moeten zijn gesmeerd met de gepast vet, geïnspecteerd En opnieuw uitgelijnd als nodig.

5. Verminderd nauwkeurigheid: Dit kan zijn veroorzaakt door verkeerde uitlijning, binding of excessief dragen. Om dit oplossen kwestie, de gids spoor En glijden blok zou moeten zijn geïnspecteerd, opnieuw uitgelijnd als noodzakelijk, gedocumenteerd met de gepast vet, en gecontroleerd voor juiste uitlijning.

## PRODUCT SPECIFICATIONS

### SBR LINEAIRE GELEIDING SPOOR

Spoor Koets Blok(SBRxxUU)





## Lineair Spoor

- Materiaal: GCR15.....45"
- Hardheid: HRC62+2(45\*:HRC58)
- OppervlakHarde dikte: 0,8~2,5 mm
- Oppervlakteruwheid: 0,8S~1,6S
- Rechtheid: 80 µm/1000 mm
- Rondheid:  $\leq 3,0 \mu\text{m}$  ( $R_{\text{max}}$ )



## Spoorwagon Blok(SBRxxUU)

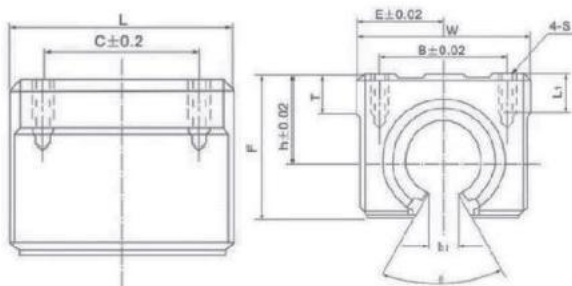

## Spoorondersteuning (SBRxx)

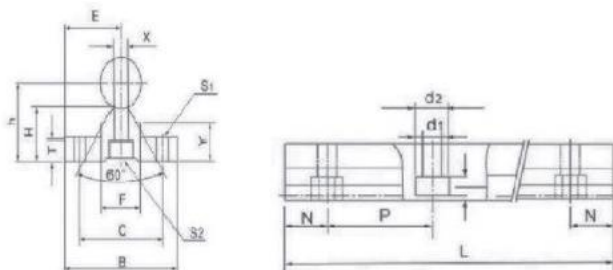

## SBR12-C 1000L

Deel naam	Afmetingen (mm)											
	H	Ik	W	Ik	F	h1	θ	B	C	S	L1	T
SBR12UU	17	20	40	39	27.6	6	80°	28	26	M5	10	7
Deel naam	Afmetingen (mm)											
	Schacht Afmetingen		Ik	H	B	H	T	F	X	Ik	C	S1
SBR12	φ12×1000L		15	22.5	32	16.5	4	12	6	12	22	φ5

## SBR16-C 2000L, 1500L, 1200L, 1000L, 800L, 600L, 500L, 400L, 300L

Deel naam	Afmetingen (mm)											
	H	Ik	W	Ik	F	h1	θ	B	C	S	L1	T
SBR16UU	20	22.5	45	45	33	10	80°	32	30	M5	12	9
Deel naam	Afmetingen (mm)											
	Schacht Afmetingen		Ik	H	B	H	T	F	X	Ik	C	S1
SBR16	φ16×800L		20	25	40	17.8	5	18.5	8	11.7	30	φ6

## SBR20-C 2200L, 1800L, 1500L, 1200L, 1000L, 800L, 650L, 600L, 300L

Deel naam	Afmetingen (mm)											
	H	Ik	W	Ik	F	h1	θ	B	C	S	L1	T
SBR20UU	23	24	48	50	39	10	60°	35	35	M6	12	11
Deel naam	Afmetingen (mm)											
	Schacht Afmetingen		Ik	H	B	H	T	F	X	Ik	C	S1
SBR20	φ20×1000L		22.5	27	45	17.7	5	19	8	10	30	φ6

## SBR25-C 1200L

Deel naam	Afmetingen (mm)											
	H	Ik	W	Ik	F	h1	$\theta$	B	C	S	L1	$\tau$
SBR25UU	27	30	60	65	47	11.5	50°	40	40	M6	12	14
Deel naam	Afmetingen (mm)											
	Schacht Afmetingen		Ik	H	B	H	T	F	X	Ik	C	S1
SBR25	Φ25×1200L		27.5	33	55	21	6	21.5	8	12	35	Φ6.5

# Specificatie tabel voor bal schroef instellen(SFU XX)

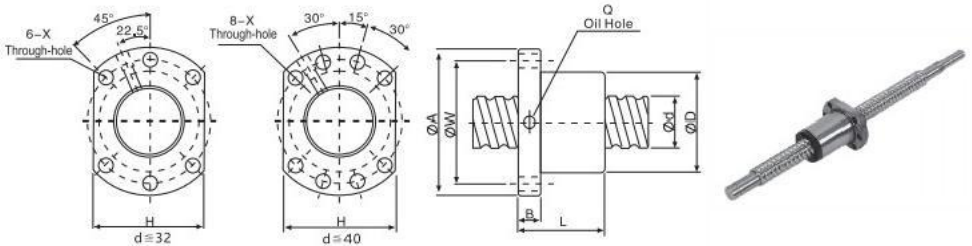

SFU1605-42000L,1700L,1500L,1050L,1000L,700L,650L ,600L,350L

Deel naam	Afmetingen (mm)														
	D	I	Ja	D	A	B	Ik	W	X	H	Q	N	Ca	Koa	Ik
SFU1605-4	16	5	3.175	28	48	10	50	38	5.5	40	M6	4	780	1790	20

## STEUN EENHEID BK

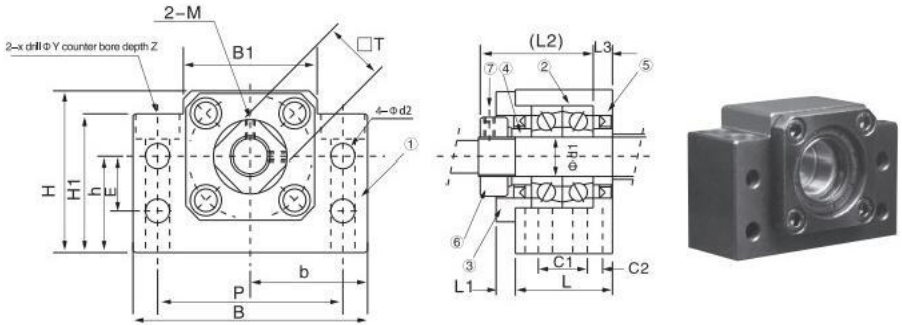

Deel naam	Schacht diameter d1	L	L1	L2	L3	B	H	B		B1	L1	E	P	C1	C2	C3	X	Y	Z	M	T
								±0,02	±0,02												
BK-12	12	25	5	29	5	60	43	30	25	35	32,5	18	46	13	6	5.5	6.5	10.8	6.5	M4	19



## STEUN EENHEID Vriendje

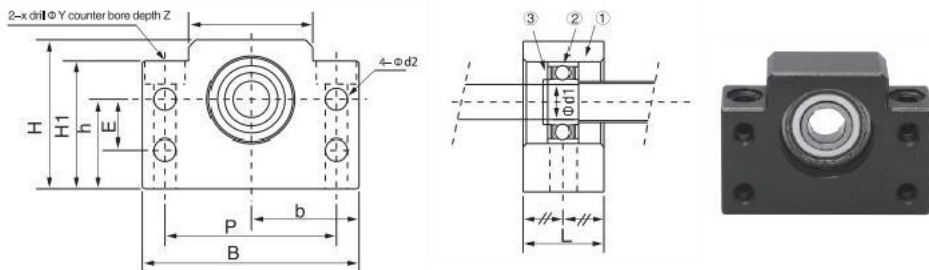

Deel naam	Schacht diameter d1	Ik	B	H	B	H	B1	H1	Ik	P	d2	X	Ik	Z	Handelswijze	Snapping
					$\pm 0,02$	$\pm 0,02$										
BF-12	12	20	60	43	30	25	35	32.5	18	46	5.5	6.6	10.8	6.5	6000ZZ	S10

## Vriendje serie Elastisch Koppeling

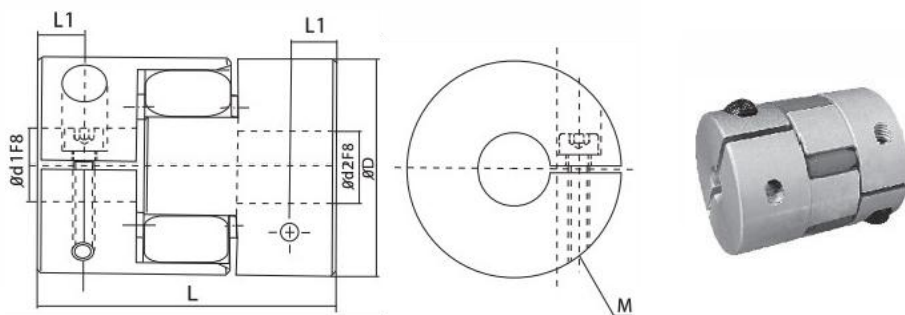

Deel naam	d1 Boren	d2 Boren	D	Ik	L1	M	Beoordeeld Koppel (Nm)	Maximaal. Koppel	Excentriciteit Fout	Schacht Engel	Maximale Rotatie (toerental)	Beoordeeld
Vriendje	5-10	5-10	25	34	5.5	M3	2Nm	35Nm	$\pm 0,2$ mm	$\leq 1^\circ$	6500	



## DSG1605

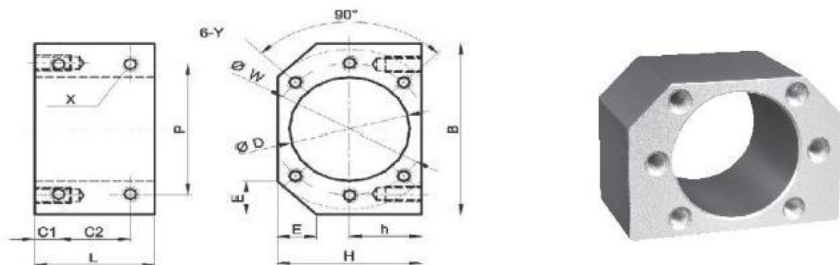

Deel naam	Schroef model	D	B	H	H	Ik	Ik	C1	C2	P	X	W	Ik
DSG 16 H	1605	28	52	40	20	12	40	8	24	40	M5	38	M5

## Afmetingen voor HGH-serie Lineaire geleiders

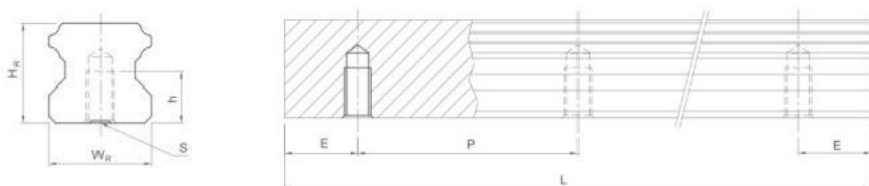

HGH151500L,1200L,300L

HGH202000L,1700L,1500L,1200L,1000L,700L,600L

Deel naam	Afmetingen (mm)						Gewicht (kg/m <sup>3</sup> )
	W	H	S	H	P	Ik	
HGH15	15	15	M5x0.8P	8	60	20	1.48
HGH20	20	17.5	M6x1P	10	60	20	2.29

# HGH-CA Serie Lineair Gids    Schuifregelaar Maat Tafel

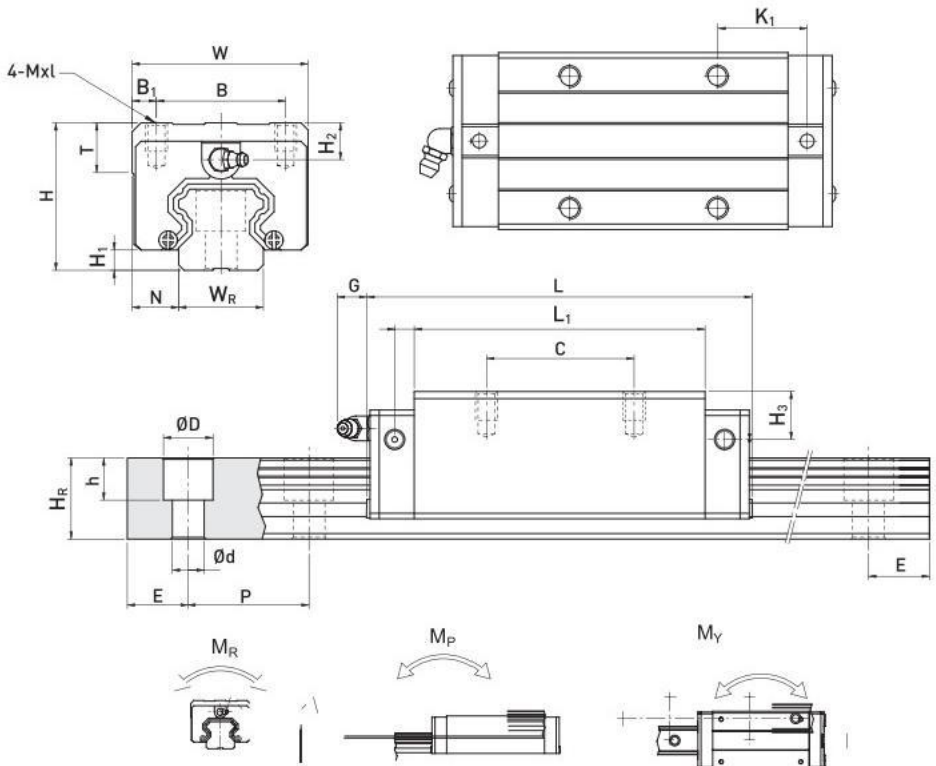

Deel naam	Afmetingen van Assemblage (mm)			Afmetingen van Blok (mm)										Afmetingen van Spoor (mm)					Monteren in g B oit voor Rai mm	Basis Dynamisch Laden Rat in g C (kN)	Basis Statisch Laden Beoordeling C. (kN)				
	H	H	N	W	B	B1	C	I	Ik	Ik	G	Mx1	T	H2	H3	W	H	D				H	D	P	e
HGH15CA	28	4.3	9.5	34	26	4	26	39.5	60.5	10	5.3	M4x5	6	7.9	7.7	15	15	7.5	5.3	4.5	60	20	M4x16	11.38	16.97
HGH20CA	30	4.6	12	44	32	6	36	50.5	72.2	12	M5x6	8	6	6	20	17.3	9.5	8.5	6	60	20	M5x16	17.75	27.76	



## LINEAIRE SCHUIF SPOOR

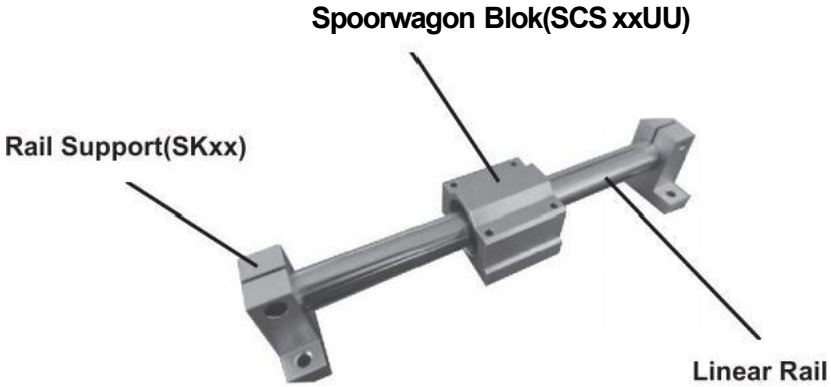

### Lineair Spoor

- Materiaal: GCR15.....45"
- Hardheid: HRC62+2(45\*:HRC58)
- Oppervlakteharde dikte: 0,8 ~ 2,5 mm
- Oppervlakteruwheid: 0,8S~1,6S
- Rechtheid: 80  $\mu\text{m}/1000\text{ mm}$
- Rondheid:  $\leq 3,0\ \mu\text{m}$  (Rmax)



### Spoorwagon Blok(SCSxxUU)

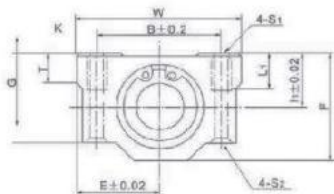
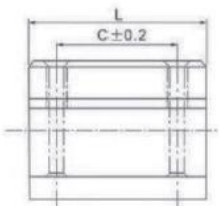

## Railondersteuning (SKxx)

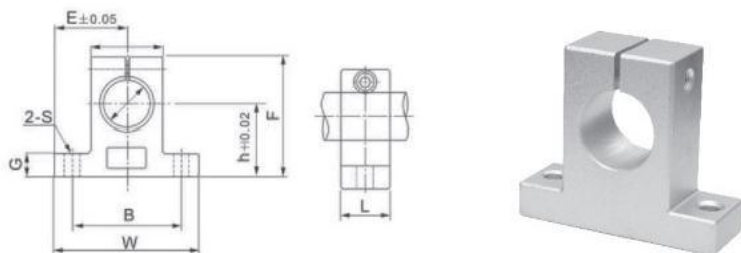

### SFC16-500L

Deel naam	Afmetingen (mm)												
	T	H	Ik	W	Ik	F	G	B	C	Ik	S1	S2	L1
SCS16UU	9	19	25	50	44	38.5	32.5	36	$\begin{matrix} 3 \\ 4 \end{matrix}$	7	M5	4.3	12
Deel naam	Afmetingen (mm)												
	Schacht Afmetingen			H	Ik	W	Ik	F	G	P	B	S	
SK16	φ 16×1000L			27	24	48	16	44	8	25	38	5.5	

### SFC16-1000L

Deel naam	Afmetingen (mm)												
	T	H	Ik	W	Ik	F	G	B	C	Ik	S1	S2	L1
SCS16UU	9	19	25	50	44	38.5	32.5	36	$\begin{matrix} 3 \\ 4 \end{matrix}$	7	M5	4.3	12
Deel naam	Afmetingen (mm)												
	Schacht Afmetingen			H	Ik	W	Ik	F	G	P	B	S	
SK16	φ 16×1000L			27	24	48	16	44	8	25	38	5.5	

**SFC20-1000L**

Deel naam	Afmetingen (mm)												
	T	H	Ik	W	Ik	F	G	B	C	Ik	S1	S2	L1
SCS20UU	11	21	27	54	50	41	35	40	40	7	M6	5.2	12
Deel naam	Afmetingen (mm)												
	Schacht Afmetingen	H	Ik	W	Ik	F	G	P	B	S			
SK20	Φ 20×1000L	31	30	60	20	51	10	30	45	6.6			

**SFC20-1200L**

Deel naam	Afmetingen (mm)												
	T	H	Ik	W	Ik	F	G	B	C	Ik	S1	S2	L1
SCS20UU	11	21	27	54	50	41	35	40	40	7	M6	5.2	12
Deel naam	Afmetingen (mm)												
	Schaf Afmetingen	H	E	W	L	F	G	P	B	S			
SK20	Φ 20×1200L	31	30	60	20	51	10	30	45	6.6			

**Fabrikant:** Shanghaimu xinmuyeyouxiangongsi

**Adres:** Shuangchenglu 803nong11hao1602A-1609shi,baoshanqu,  
shanghai 200000 CN.

**Geïmporteerd naar AUS:** SIHAO PTYLTD,1  
ROKEVASTREETEASTWOOD NSW 2122 Australië

**Geïmporteerd naar VS :** Sanven Technologie Ltd.,Suite 250,9166  
Anaheim Plaats, Rancho Cucamonga, CA91730

EC	REP
----	-----

E-CrossStu GmbH  
Mainzer Landstraat 69,60329 Frankfurt ben Voornaamst.

UK	REP
----	-----

YH-CONSULTING BEPERKT.  
C/O-YH Advies Beperkt Kantoor 147,Centurion Huis,  
Londen Road, Staines-upon-Thames, Surrey, TW184AX

**VEVOR**<sup>®</sup>

**TOUGH TOOLS, HALF PRICE**

**Technische ondersteuning en E-garantie  
certificaat ate [www.vevor.com/support](http://www.vevor.com/support)**

# VEVOR®

## TOUGH TOOLS, HALF PRICE

Teknisk support och E-garanticertifikat [www.vevor.com/support](http://www.vevor.com/support)

### LINJÄR GUIDE JÄRNVÄG

Vi fortsätter att vara engagerade i att tillhandahålla y ou verktyg med konkurrenskraftig pris.

"Spara Hälften", "Hälften Pris" eller några andra liknande uttryck begagnad av oss endast representerar en uppskattning av besparingar du kan dra nytta av att köpa viss verktyg med oss jämför d till de större bästa varumärken och gör inte nödvändigtvis menar att täcka alla kategorier av verktyg erbjuds av oss. Du är vänligt påminns om att noggrant kontrollera när du är placering en beställa med oss om du är faktiskt sparar hälften i jämförelse med de bästa större varumärken.

# VEVOR<sup>®</sup>

TOUGH TOOLS, HALF PRICE



SBR

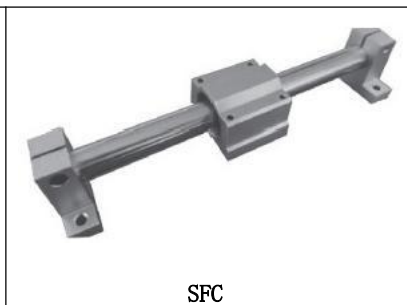

SFC



SFU



HGH

## NEED HELP?CONTACT US!

Have product questions?Need technical support?Please feel free to contact us:

Technical Support and E-Warranty Certificate [www.vevor.com/support](http://www.vevor.com/support)

Detta är den ursprungliga instruktionen, tack läsa alla manuell instruktioner noggrant före drift.V EVOR reserverar en klar tolkning av vår användarmanual. Produktens utseende ska vara ämne till de produkt du fått. Förlåt oss att vi inte kommer att göra det i form du igen om det finns några teknologi eller programvara uppdateringar o n vår produkt.





### WARNING:

Läs detta material innan använder detta produkt. Misslyckande re till do så burk resultat i allvarlig skada.

### SPARA DETTA MANUELL

#### Försiktighetsåtgärder

1. Riktigt installation :Linjär guide skenor måste vara installerat ordentligt till säkerställa exakt och jämna rörelse. Olämplig installation burk orsaka m inriktning, bindande, eller överdrivet bära.
2. Ladda kapacitet: Se till att använd a linjär styrning skena med a ladda kapacitet att är tillräckligt för vikten av flyttar del. Överbelastning av guide järnväg burk orsaka överdrivet slitage eller permanent skada.
3. Underhåll: Regelbunden rengöring och smörjning av guide järnväg och glidande blockera är viktigt att upprätthålla korrekt prestanda och utöka tjänsten livet av guide järnväg.
4. Alignment: Se till att linjär styrning järnväg är ordentligt inriktad och vinkelrätt mot färdriktningen för att minska friktion och slitage.
5. Miljömässigt villkor: Linjär guide skenor skall vara skyddas från extrema temperaturer, fukt, damm och andra miljö- villkor att burk påverka prestanda.
6. Skydd från impact: L inear guide skenor bör vara skyddas från påverkan och andra källor till chock, som dessa kan orsaka skada på de järnväg eller glidande blockera.

## **IMPORTANT SAFETY INFORMATION**

7. Inspektion: Regelbunden inspektion av guiden skena och glidande blockera är viktigt att identifiera och åtgärda eventuella problem eller slitage innan de bli allvarlig.

## Felsökning

1. Bindning eller sticker: Det här brukar därför av feljustering, imprecis smörjning, eller överdrivet slitage. To lösa detta frågan, den guide järnväg och glidande block skall vara

inspekterade och omriktat om det behövs, och smord med lämplig fett.

2. Överdriven slitage: Detta brukar vara orsakade av överbelastning, olämplig smörjning, eller feljustering. Till lösa detta frågan, den ladda på de guide järnväg skall vara nedsatt, och guiden skena och glidande block bör vara inspekterade, omjusterade om nödvändigt och smord med lämpligt fett.

3. Feljustering : Detta brukar därför av felaktig installation eller av bära över tid . Till lösa detta fråga, guiden skena och glidande block bör vara inspekterad och justerade om nödvändig.

4. Bullrigt operation: Detta brukar därför av a brist av smörjning, felinställning eller överdrivet slitage. To lösa detta frågan, den guide järnväg och glidning blockera skall vara smord med lämplig fett, besiktigad och omriktat om nödvändig.

5. Minskad noggrannhet: Detta brukar vara orsakade av feljustering, bindning , eller överdrivet wear. To lösa detta frågan, den guide järnväg en d glidande blockera skall vara inspekterade, omriktade om nödvändigt, jag smord med de lämplig fett och kontrollerade för korrekt inriktning.

## PRODUCT SPECIFICATIONS

### SBR LINJÄR GUIDE JÄRNVÄG

Järnväg Transport Block(SBRxxUU)

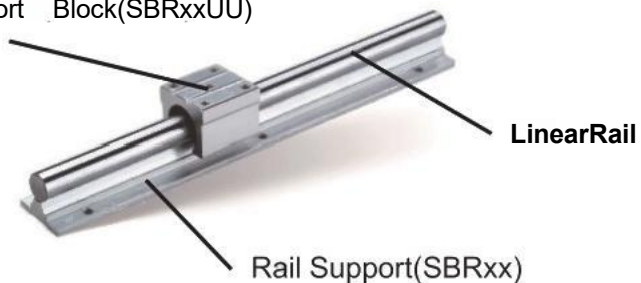

## Linjär Järnväg

- Material: GCR15.....45"
- Hårdhet: HRC62+2(45\*:HRC58)
- Ytan hård-tjocklek: 0,8 ~ 2,5 mm
- Ytjämnhet: 0,8S~1,6S
- Rakhet:80µm/1000mm
- Rundhet:≤3,0µm(Rmax)



## Järnvägsvagn Block(SBRxxUU)

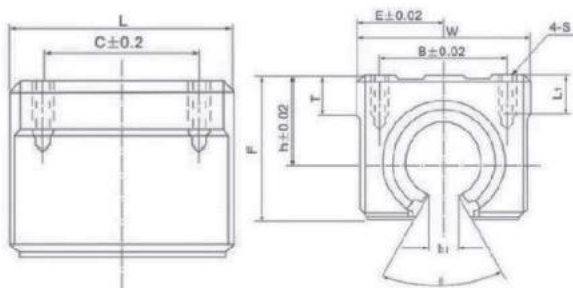

## Rail Support (SBRxx)

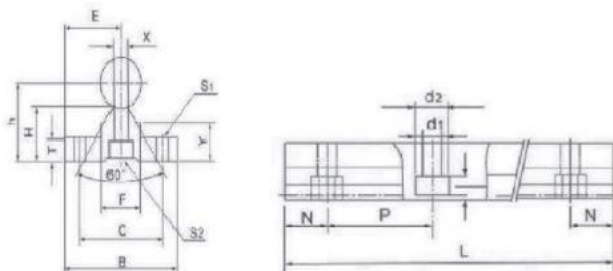

## SBR12-C 1000L

Del namn	Mått (mm)											
	h	E	W	L	F	h1	θ	B	C	S	L1	T
SBR12UU	17	20	40	39	27.6	6	80°	28	26	M5	10	7
Del namn	Mått (mm)											
	Axel Mått		E	h	B	H	T	F	X	Y	C	S1
SBR12	Φ12×1000L		15	22.5	32	16.5	4	12	6	12	22	Φ5

## SBR16-C 2000L,1500L,1200L,1000L,800L,600L,500L,400L,300L

Del namn	Mått (mm)											
	h	E	W	L	F	h1	θ	B	C	S	L1	T
SBR16UU	20	22.5	45	45	33	10	80°	32	30	M5	12	9
Del namn	Mått (mm)											
	Axel Mått		E	h	B	H	T	F	X	Y	C	S1
SBR16	Φ16×800L		20	25	40	17.8	5	18.5	8	11.7	30	Φ6

## SBR20-C 2200L,1800L,1500L,1200L,1000L,800L,650L,600L,300L

Del namn	Mått (mm)											
	h	E	W	L	F	h1	θ	B	C	S	L1	T
SBR20UU	23	24	48	50	39	10	60°	35	35	M6	12	11
Del namn	Mått (mm)											
	Axel Mått		E	h	B	H	T	F	X	Y	C	S1
SBR20	Φ20×1000L		22.5	27	45	17.7	5	19	8	10	30	Φ6

## SBR25-C 1200L

Del namn	Mått (mm)											
	h	E	W	L	F	h1	$\theta$	B	C	S	L1	$\tau$
SBR25UU	27	30	60	65	47	11.5	50°	40	40	M6	12	14
Del namn	Mått (mm)											
	Axel Mått		E	h	B	H	T	F	X	Y	C	S1
SBR25	Φ25×1200L		27.5	33	55	21	6	21.5	8	12	35	Φ6.5

## Specifikation tabell för boll skruva set (SFU XX)

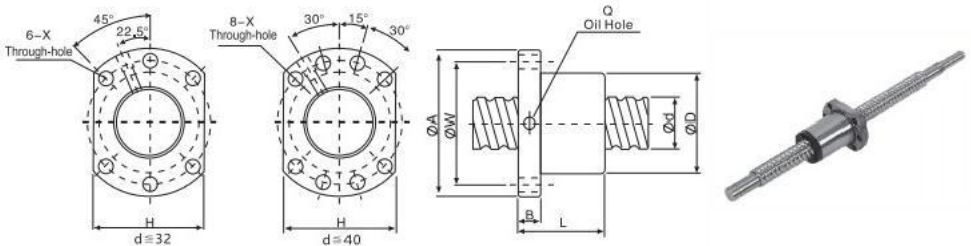

SFU1605-42000L,1700L,1500L,1050L,1000L,700L,650L ,600L,350L

Del namn	Mått (mm)														
	d	l	Ja	D	A	B	L	W	X	H	F	N	Ca	Coa	K
SFU1605-4	16	5	3,175	28	48	10	50	38	5.5	40	M6	4	780	1790	20

## STÖD ENHET BK

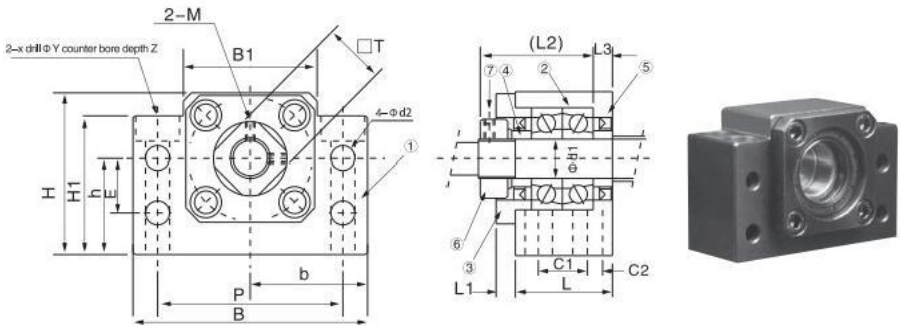

Del namn	Axel diameter d1	L	L1	L2	L3	B	H	b	h	B1	L1	E	P	C1	C2	C3	X	Y	Z	M	T
								±0,02	±0,02												
BK-12	12	25	5	29	5	60	43	30	25	35	32,5	18	46	13	6	5.5	6.5	10.8	6.5	M4	19



# STÖD ENHET BF

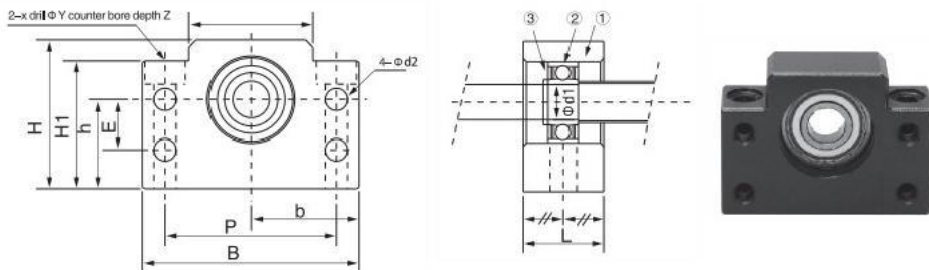

Delnamn	Axeldiameter d1	L	B	H	b	h	B1	H1	E	P	d2	X	Y	Z	Lager	Knäppning
					$\pm 0,02$	$\pm 0,02$										
BF-12	12	20	60	43	30	25	35	32,5	18	46	5.5	6.6	10.8	6.5	6000ZZ	S10

## BF serie Elastisk Koppling

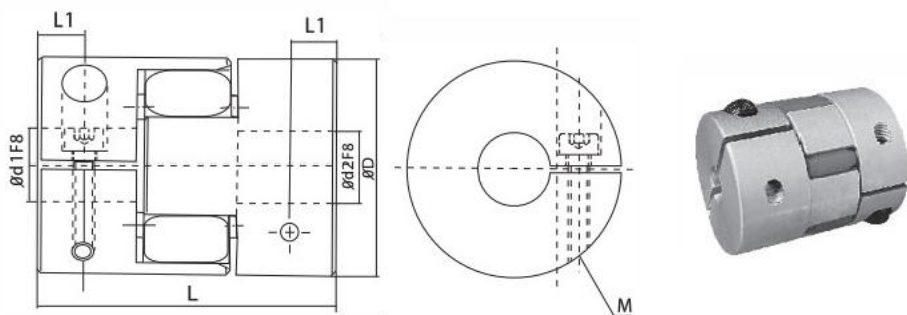

Delnamn	d1 Borr a	d2 Borr a	D	L	L1	M	Betygsatt Vridmo ment (Nm)	Max. Vridmo ment	Ecce ntricit y Fel	Axel Ängel	Max. Roterande (rpm)	Betygs att
BF	5-10	5-10	25	34	5.5	M3	2N.m	35N.m	$\pm 0,2$ mm	$\leq 1^\circ$	6500	



## DSG1605

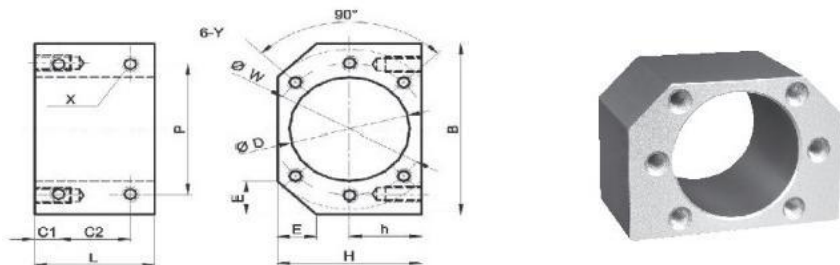

Del namn	Skruv a model l	D	B	H	h	E	L	C1	C2	P	X	W	Y
DSG 16 H	1605	28	52	40	20	12	40	8	24	40	M5	38	M5

## Mått för HGH-serien Linjära styrbanor

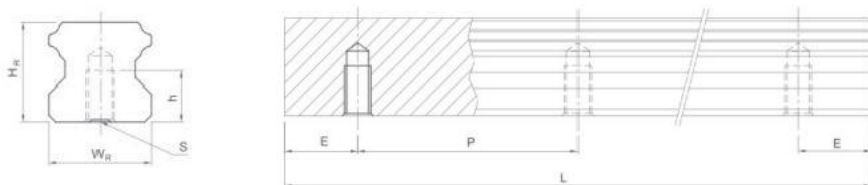

HGH151500L,1200L,300L

HGH202000L,1700L,1500L,1200L ,1000L,700L,600L

Del namn	Mått (mm)						Vikt (kg/m)
	W	H	S	h	P	E	
HGH15	15	15	M5x0,8P	8	60	20	1,48
HGH20	20	17.5	M6x1P	10	60	20	2,29

# HGH-CA Serie Linjär Guide Skjutreglage Storlek Tabell

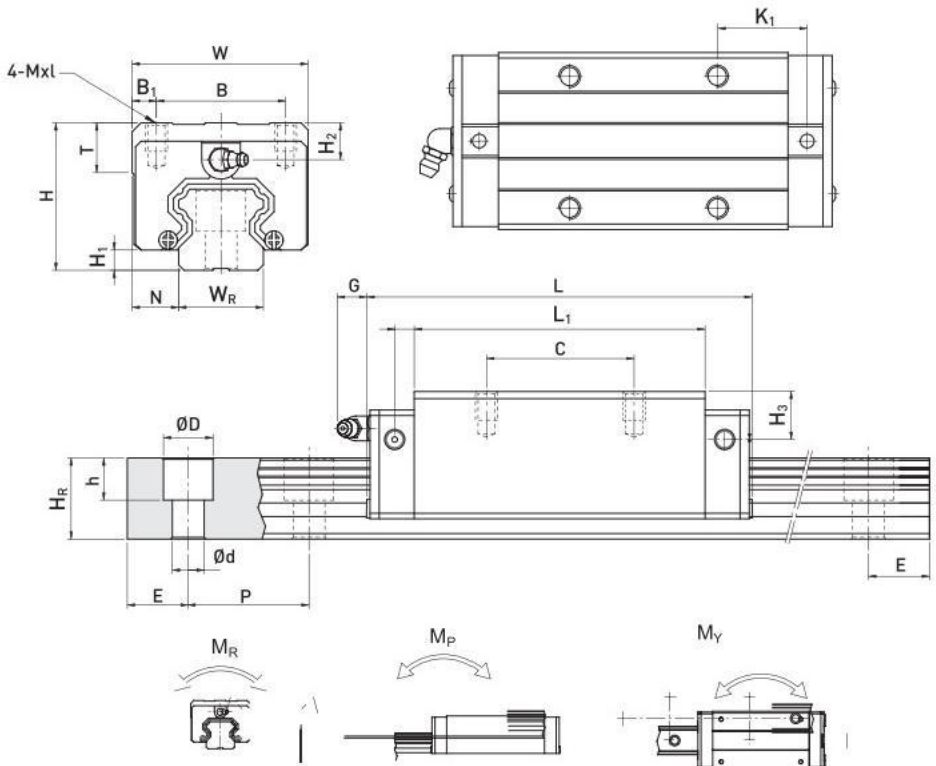

Delnamn	Mått av Assembly (mm)		Mått av Blockera (mm)													Mått av Järnväg (mm)						Monterings Rättig	Grundläggande Statiska Ladda Gradering	Grundläggande Statiska Ladda Gradering	
	H	H	N	W	B	B1	C	L	L	K	G	Mxl	T	H2	H3	W	H	D	h	d	P				e
HGH15CA	28	4.3	9.5	34	26	4	26	39.5	60.5	10	5.3	M4x5	6	7.9	7.7	15	15	7.5	5.3	4.5	60	20	M4x16	11,38	16,97
HGH20CA	30	4.6	12	44	32	6	36	50.5	76.7	2.2	12	M8x5	6	8	6	20	17.5	9.5	8.5	6	60	20	M5x16	17.75	27,76



## LINJÄR SLID JÄRNVÄG

### Järnvägsvagn Block (SCS xxUU)



### Linjär Järnväg

- Material: GCR15.....45"
- Hårdhet: HRC62+2(45\*:HRC58)
- Ytans hårda tjocklek: 0,8 ~ 2,5 mm
- Ytjämnhet: 0,8S~1,6S
- Rakhet:80µm/1000mm
- Rundhet:≤3,0µm(Rmax)



### Järnvägsvagn Block(SCSxxUU)

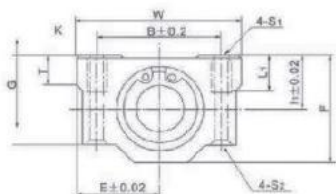
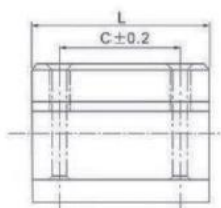

## Rail Support (SKxx)

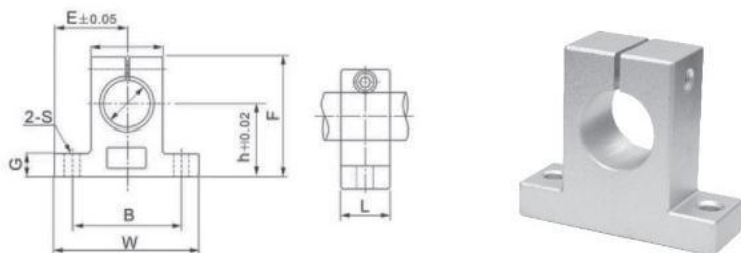

### SFC16-500L

Del namn	Mått (mm)												
	T	h	E	W	L	F	G	B	C	K	S1	S2	L1
SCS16UU	9	19	25	50	44	38,5	32,5	36	$\begin{matrix} 3 \\ 4 \end{matrix}$	7	M5	4.3	12
Del namn	Mått (mm)												
	Shaf Mått		h	E	W	L	F	G	P	B	S		
SK16	ϕ 16×1000L		27	24	48	16	44	8	25	38	5.5		

### SFC16-1000L

Del namn	Mått (mm)												
	T	h	E	W	L	F	G	B	C	K	S1	S2	L1
SCS16UU	9	19	25	50	44	38,5	32,5	36	$\begin{matrix} 3 \\ 4 \end{matrix}$	7	M5	4.3	12
Del namn	Mått (mm)												
	Shaf Mått		h	E	W	L	F	G	P	B	S		
SK16	ϕ 16×1000L		27	24	48	16	44	8	25	38	5.5		

**SFC20-1000L**

Del namn	Mått (mm)												
	T	h	E	W	L	F	G	B	C	K	S1	S2	L1
SCS20UU	11	21	27	54	50	41	35	40	40	7	M6	5.2	12
Del namn	Mått (mm)												
	Shaf Mått		h	E	W	L	F	G	P	B	S		
SK20	Φ 20×1000L		31	30	60	20	51	10	30	45	6.6		

**SFC20-1200L**

Del namn	Mått (mm)												
	T	h	E	W	L	F	G	B	C	K	S1	S2	L1
SCS20UU	11	21	27	54	50	41	35	40	40	7	M6	5.2	12
Del namn	Mått (mm)												
	Shaf Mått		h	E	W	L	F	G	P	B	S		
SK20	Φ 20×1200L		31	30	60	20	51	10	30	45	6.6		

**Tillverkare:** Shanghaimu xinmuyeyouxiangongsi

**Adress:** Shuangchenglu 803nong11hao1602A-1609shi,baoshanqu,  
shanghai 200000 CN.

**Importerad till AUS:** SIHAO PTYLTD,1 ROKEVASTREETEASTWOOD  
NSW 2122 Australien

**Importerad till USA:** Sanven Teknologi Ltd., svit 250,9166 Anaheim Place,  
Rancho Cucamonga, CA91730

EC	REP
----	-----

E-CrossStu GmbH  
Mainzer Landstr.69,60329 Frankfurt am Main.

UK	REP
----	-----

YH KONSULTAT BEGRÄNSAD.  
C/O YH Konsultverksamhet Begränsad Kontor 147,  
Centurion Hus, London Road, Staines-upon-Thames,  
Surrey, TW184AX

**VEVOR**<sup>®</sup>

**TOUGH TOOLS, HALF PRICE**

**Teknisk support och E-garanticertifikat åt  
[www.vevor.com/support](http://www.vevor.com/support)**