

Halogen Oven

User's manual

EN



SENCOR®

SMH 330

Prior to using this appliance, please read the user's manual thoroughly, even in cases, when one has already familiarised themselves with previous use of similar types of appliances. Only use the appliance in the manner described in this user manual. Keep the user's manual in a safe place where it can be easily retrieved for future use.

We recommend saving the original shipping cardboard box, packaging material, receipt and warranty card for the duration of warranty. In the case of transportation, pack the appliance using the original packaging materials only.

EN-1

CONTENTS

IMPORTANT SAFETY INSTRUCTIONS	3
DESCRIPTION OF THE HALOGEN OVEN	5
DESCRIPTION OF THE CONTROL UNIT.....	6
BASIC CHARACTERISTICS OF A HALOGEN OVEN	6
METHODS FOR COOKING FOOD IN A HALOGEN OVEN	7
TIPS FOR COOKING FOOD IN A HALOGEN OVEN.....	9
BEFORE FIRST USE	9
OPERATION OF THE HALOGEN OVEN.....	9
HALOGEN OVEN COOKING GUIDE.....	11
CLEANING AND MAINTENANCE.....	12
TECHNICAL SPECIFICATIONS	12
RECIPES	13
INSTRUCTIONS AND INFORMATION REGARDING THE DISPOSAL OF USED PACKAGING MATERIALS	17
DISPOSAL OF USED ELECTRICAL AND ELECTRONIC EQUIPMENT.....	17

IMPORTANT SAFETY INSTRUCTIONS

This appliance may be used by children 8 years of age and older and by persons with physical or mental impairments or by inexperienced persons if they are properly supervised or have been informed about how to use of the product in a safe manner and understand the potential dangers. Children must not play with the appliance. This appliance may be cleaned by children 8 years of age and older if they are properly supervised. Keep this appliance and the power cord out of reach of children younger than 8 years of age.

IMPORTANT SAFETY INSTRUCTIONS READ CAREFULLY AND STORE FOR FUTURE USE

- Before connecting the appliance to a power socket check that the voltage stated on the rating label of the appliances matches the electrical voltage in the socket.
- Only plug the appliance into a correctly grounded socket.



Attention:

This appliance is not designed to be controlled using a programmed device, external timer switch or remote control.

- This appliance is designed for home use. Do not use the product outdoors.
- Do not place the appliance on window sills or on unstable surfaces. Only place the appliance on a stable, even, dry surface.
- Do not place the appliance on an electric or gas stove or in its vicinity, do not place it in the vicinity of an open fire or an appliance that is a source of heat.
- This appliance is designed for processing food by cooking. Do not use it for other purposes.
- Only use the appliance with original accessories from the manufacturer.
- Before connecting this appliance to the socket outlet ensure that it is properly assembled.
- When the appliance is operating there needs to be sufficient area for air circulation above the appliance and around it. Do not use the appliance near flammable materials such as curtains, kitchen towels, wooden surfaces, etc.



Attention: Hot surface

When the appliance is operating the body and lid are heated up. Do not touch the hot surface. This could cause skin burns. For lifting and carrying the lid use the fold-down handle. To carry the bowl use the handles on the stand. To remove a hot rack from the bowl use the tongs supplied with this appliance.

- Do not pour cold water into the glass bowl when it is hot. This could damage it.
- Be very careful when handling the glass bowl containing hot liquid.
- Only place the lid on a heat resistant surface.
- Always disconnect the appliance from the power socket if you wish to remove the lid or if you will not be using it, before moving it and if you leave it without supervision. Allow the appliance and its accessories to cool down after you have finished using them.
- Do not rinse the lid with the control unit under running water or submerge it in water or another liquid.
- Ensure that the power cord does not come into contact with water or moisture.
- Do not place heavy items on the power cord. Make sure the power cord does not hang over the edge of a table, or that it does not touch a hot surface.
- Do not disconnect the appliance from the power socket by pulling on the power cord. This could damage the power cord or the power socket. Disconnect the cord from the power socket by gently pulling out the plug of the power cord.
- Do not use the appliance if its power cord or power plug is damaged or if it is not working correctly or if it is damaged. Any repair of the appliance or replacement of a damaged power cord may only be carried out by an authorised service centre or another similarly qualified person, as this will prevent causing a dangerous situation.

Halogen Oven

SMH 330

EN

DESCRIPTION OF THE HALOGEN OVEN

A

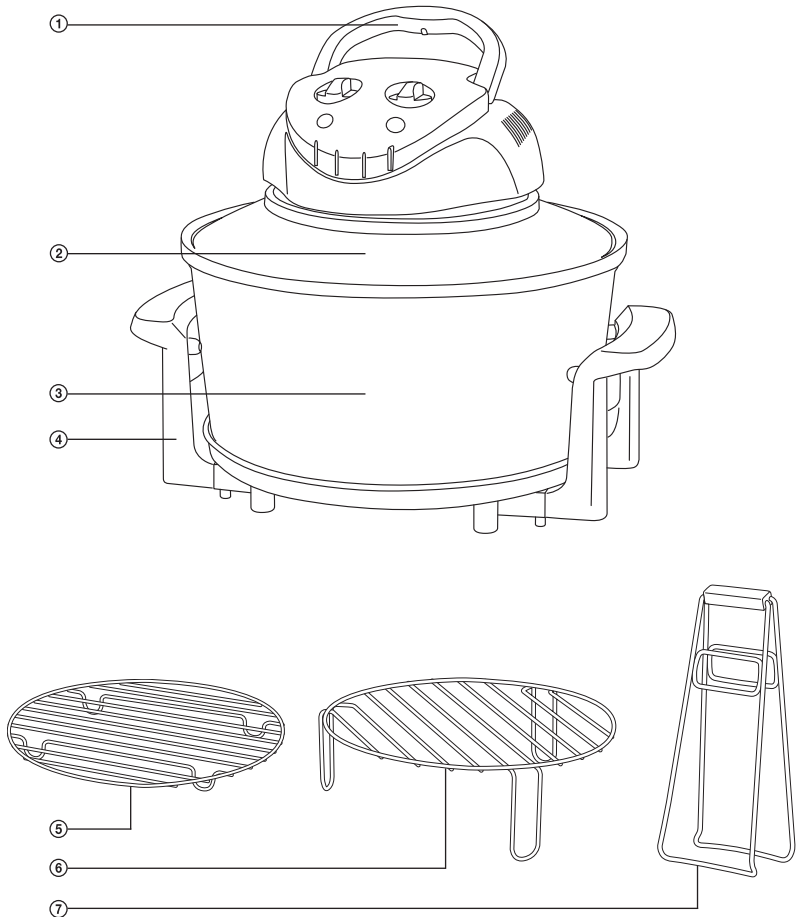

- ① Fold-down handle with a safety switch
- ② Lid with the control unit
- ③ Removable glass bowl
- ④ Stand with handles

- ⑤ Low rack
- ⑥ High rack
- ⑦ Tongs

EN-5

DESCRIPTION OF THE CONTROL UNIT

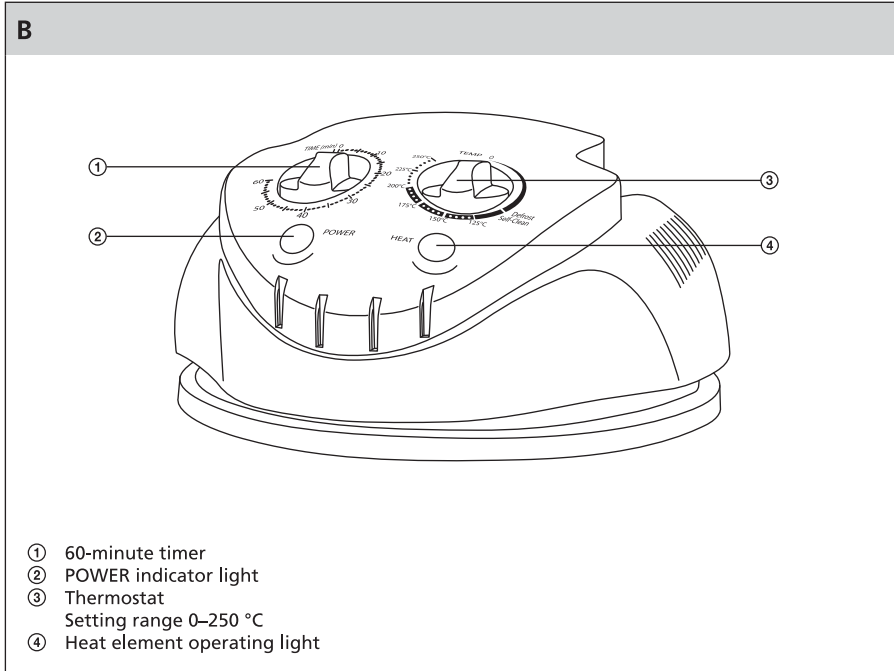

BASIC CHARACTERISTICS OF A HALOGEN OVEN

- It can be used to prepare food in several ways, such as baking, grilling, stewing, toasting and defrosting.
- Preparing meals is up to 40 % faster than in a standard oven.
- It has a lower power consumption than a standard oven.
- It makes it possible to prepare healthy meals using only a minimum amount of fat.
- Circulation of hot air ensures that the meal is baked evenly.
- Self-clean function for easy and quick cleaning.
- Its compact size makes it suitable also when travelling.

METHODS FOR COOKING FOOD IN A HALOGEN OVEN

Roasting meat

- Insert the rack into the bowl. Place the meat on the rack and only add enough water so that the bottom of the bowl is covered. The roasting time depends on the size of the meat and the desired degree to which it is to be roasted.
- Roasted breaded meat. Roll portioned pieces of chicken meat (breasts, wings or drumsticks) in flour, then egg and then breadcrumbs and then dip it for a short time in cooking vegetable oil. Allow excess oil to drip off. Place the rack inside the bowl and place the meat on to it. The recommended cooking time and temperature are described in the chapter Cooking Guide.

Baking French fries

- In this halogen oven you can prepare French fries that are just as tasty as those cooked in a deep fryer but much healthier without the need to fry them in oil. Dip the French fries for a short time in cooking vegetable oil. Allow excess oil to drip off. Place the rack inside the bowl and evenly spread the French fries over it. The recommended cooking time and temperature are described in the chapter Cooking Guide.

Baking cakes, biscuits and bread

- Place the low rack into the bowl. Place the dough into a round baking bowl (or baking pan). Place the bowl on the rack. A space of 2 to 3 cm must remain between the baking bowl and the walls of the oven bowl so that air is allowed to circulate sufficiently. You may cover the dough with aluminium foil. Make sure that the aluminium foil is properly secured to the sides of the baking bowl. Uncover the dough before it has finished baking to allow its surface to bake a little.
- Baking cakes, biscuits or bread in a halogen oven is faster than in a standard oven and so it is necessary to regularly check it while baking.

Grilling meat

- Place the rack inside the bowl and place the meat on to it. In the middle of the grilling time turn over the thicker slices or larger pieces of meat. Just the same as when roasting, the grilling time depends on the size of the meat and the desired degree to which it is to be cooked.

Stewing vegetables

- Together with the main meal you can also prepare vegetables in the steam at the same time. Use aluminium foil to make a bag. Insert the vegetables into the bag and add a few drops of water. To add flavour you can use herbs or spices. Close the bag and place it on the bottom of the glass bowl. Add a cup of water. The main meal is prepared on the rack.
- You can cook fish in the same way. Place the fish into a bag made from aluminium foil, add a little water, lemon juice, herbs or spices and vegetables depending on your taste. The fish will be stewed in its own juices.

Toasting

- In this halogen oven you can easily and quickly heat up older bread or rolls. Place the rack inside the bowl and place the bread or rolls on it. The heated bread or rolls will have a crispy crust and will be soft inside.
- If you want to make older biscuits crunchy again, allow them to heat up for a few minutes at maximum temperature and they will again taste as if they were fresh.

Defrosting meals

- Foods will be defrosted in this halogen oven more evenly than in a microwave oven. Set the thermostat to the Defrost position. Select the defrosting time as necessary and regularly check the condition of the food every 5 to 10 minutes.
- When cooking frozen ready meals (e.g. pizza) set the temperature 20 °C lower and the cooking time 30 to 50 % shorter than indicated by the manufacturer of the frozen food for a standard oven.

TIPS FOR COOKING FOOD IN A HALOGEN OVEN

- Before placing food on the rack, you can apply cooking oil using a spray bottle so that the food does not stick to the rack.
- Always spread the food on the rack in such a way that air in the bowl can circulate freely and that the food is evenly cooked.
- Regularly check the condition of the food by looking through the glass bowl.

BEFORE FIRST USE

- 1) Before first use take the halogen oven and its accessories out of the packaging material.
- 2) Rinse the glass bowl under running hot water and wipe dry and place it on the stand.
- 3) Place the lid on the bowl and connect the power cord to a power socket.
- 4) To remove any possible odours from manufacturing, set the thermostat to 250 °C and the timer to 5 minutes.



Note:

When first turned on there may be light smoke emitted. This is a completely normal event.

- 5) At the end of the set cooking time a sound is made and the heating element and fan will turn off. Disconnect the power cord from the el. power socket. Remove the lid and place it on a heat-resistant mat. Allow the appliance to cool down.

OPERATION OF THE HALOGEN OVEN

- 1) Place the glass bowl on the stand. Select the type of rack you wish to use and place it inside the glass bowl. In the chapter Cooking Guide you will find the recommended type of rack for the selected type of food.
- 2) Arrange the food on the rack. A space of 2–3 cm must remain between the food and the walls of the bowl so that air circulation inside the bowl is not impaired. Make sure that food is arranged evenly. Avoid arranging the food in layers. Otherwise only the top and bottom layer of the food will be cooked.
- 3) Cover the bowl using the lid with the control unit. Connect the power cord to the el. power socket.
- 4) To put the oven into operation set the thermostat and the timer. The chapter Cooking Guide describes the recommended cooking temperature and cooking time for selected food types.
- 5) The oven will reach the set temperature in a short time. The thermostat maintains the set temperature by switching the heating element on and off. This is indicated by the indicator light ④ switching on and off. Regularly check the condition of the food by looking through the glass bowl. If it is necessary to turn the food over during the cooking process, disconnect the power plug from the el. power socket. Remove the lid with the control unit and place it on a heat-resistant mat. Turn the food over. Return the lid and connect the power plug to the power socket.



Note:

If you do not disconnect the power plug from the el. power socket when you lift the fold-down handle, the safety switch will automatically be activated turning off the heating element.

The timer counts down the time even while the oven is disconnected from the el. power socket.



Warning:

Be very careful when removing the lid so that you do not get scolded by the escaping steam.

Halogen Oven

SMH 330

- 6) At the end of the set cooking time a sound is made and the heating element and fan will turn off. Disconnect the power plug from the el. power socket. Remove the lid with the control unit and place it on a heat-resistant mat. Remove the food and allow the oven to cool down before moving or cleaning it.

**Note:**

If you wish to stop the operation of the appliance earlier, set the thermostat and the timer to position 0.

Halogen Oven

SMH 330

EN

HALOGEN OVEN COOKING GUIDE

TYPE OF FOOD	COOKING TIME	SETTING THE TEMPERATURE	TYPE OF RACK
Poultry <ul style="list-style-type: none">• Whole chicken• Chicken pieces• Turkey• Duck	35–40 min 15–20 min 60–90 min 50–60 min	200 °C 200 °C 200 °C 200 °C	Low High Low Low
Beef Roast beef (1,5 kg) <ul style="list-style-type: none">• Rare• Medium rare• Well done Steak <ul style="list-style-type: none">• Medium rare	35–40 min 45–50 min 55–60 min 8–10 min	175 °C 175 °C 175 °C 250 °C	Low Low Low High
Mutton Lamb roast (2 kg) <ul style="list-style-type: none">• Medium rare• Well done	60–70 min 80–90 min	200 °C 200 °C	Low Low
Smoked goods <ul style="list-style-type: none">• Sausages	10 min	200 °C	Low
Eggs <ul style="list-style-type: none">• Hard-boiled• Soft-boiled• Omelette	6–7 min 4–5 min 10–12 min	200 °C 200 °C 175 °C	Low Low Low
Cake <ul style="list-style-type: none">• Without filling• With filling	20–25 min 35–40 min	200 °C 175 °C	Low Low
Danish pastry <ul style="list-style-type: none">• Without filling• With filling	10–12 min 25–30 min	200 °C 175 °C	High Low
Pastry from yeast dough <ul style="list-style-type: none">• Loaf of bread• Bread rolls	15–20 min 15–20 min	175 °C 175 °C	Low Low
Frozen goods <ul style="list-style-type: none">• Pizza	10 min	200 °C	High
Seafood <ul style="list-style-type: none">• Fish• Prawns• Clams• Lobster	7–10 min 8–10 min 3–5 min 12–15 min	200 °C 200 °C 160 °C 175 °C	High High Low Low
Vegetables <ul style="list-style-type: none">• Baked potatoes (cut into quarters)• French fries	20–35 min 12–15 min	250 °C 200 °C	Low High



Note:

The above cooking times are only a reference.

CLEANING AND MAINTENANCE

- Before cleaning the appliance disconnect it from the el. power socket and allow it to cool down.
- Wash the glass bowl in a solution of warm water and kitchen detergent. Then rinse with clean water and wipe dry. To remove baked on food remains use a nylon brush.
- Clean the lid and the fan cover using a soft sponge moistened in a solution of warm water and neutral kitchen detergent. After applying the kitchen detergent wipe the lid and the fan cover using a lightly damp cloth and dry thoroughly.
- Do not submerge the lid under water or any other liquid and ensure that water or any other liquid do not enter the lid or the control unit.
- To clean any part of this appliance do not use steel wool, abrasive cleaning products or solvents.

Self-clean function

- Thanks to this function baked on food remains are removed from the glass bowl. This makes cleaning the glass bowl easier and faster.
- Fill the bowl up to about 4 cm with a solution of water and neutral kitchen detergent. If you used the rack for cooking, you can leave it in the bowl. Place the lid with the control unit on the bowl. Connect the power cord to the el. power socket.
- Turn the thermostat to the "self-clean" position and set the timer to 10 minutes. The halogen oven will commence the self cleaning programme. As the hot air circulates inside the bowl, baked on food remains are released from the wall of the bowl.
- After the self cleaning programme has finished, disconnect the appliance from the el. power socket and remove the lid with the control unit. Rinse out the bowl with clean water to remove all detergent and food remains. It will be necessary to finish washing the rack with a nylon brush.



Note:

If not all the food remains have been removed from the wall of the bowl you can restart the self-clean programme for a further 2 to 3 minutes.

TECHNICAL SPECIFICATIONS

Nominal voltage range.....	220–240 V
Nominal frequency.....	50/60 Hz
Rated power input.....	1200–1400 W
Volume.....	12 l

We reserve the right to change text and technical specifications.

RECIPES CONTENTS

CROISSANTS.....	14
BREAD ROLLS.....	14
BAKED BACON	14
BEEF SIRLOIN WELLINGTON.....	14
FILLED VEAL BREAST	15
CHICKEN WINGS BAKED IN HONEY	15
ROAST CHICKEN	15
BAKED VEGETABLES.....	16
POTATOES BAKED IN ALUMINIUM FOIL	16
CAULIFLOWER AU GRATIN	16

Croissants

Heating up to make crisp 3 to 4 pcs

Set the thermostat to 125 °C and allow the oven to preheat for a few minutes. It takes 3 to 6 minutes to heat them up. If you wish the heat up and make crisp frozen croissants, it will be necessary to extend the time to 6 to 10 minutes.

Bread rolls

Making bread rolls from the previous day crisp again

Lightly dampen the bread rolls using a silicone brush. Place them on the high rack and bake for approximately 5 to 10 minutes at a temperature of 125 °C. The heated bread rolls will taste as if they were freshly baked.

Baked bacon

Rashes of English bacon

Spread the bacon rashes on the high rack and set the thermostat to 230 °C. Bake the bacon rashes for approximately 6 to 8 minutes or until they are baked to your taste.

Beef sirloin Wellington

700 g of beef sirloin, 4 tablespoons of olive oil, 1 onion, 1 bread roll, 3 tablespoons of butter, 350 g minced chicken meat, 2 eggs, 1 yolk, 4 tablespoons of whipping cream, salt, pepper, 1 tablespoon of Worcester sauce, half a teaspoon of ground sweet paprika, 1 pack of Danish pastry dough

Wash the sirloin, clean it and lightly cover with oil. In a deep pan fry it on oil for approximately 15 minutes. Take the meat out and allow it to cool down. Cut the bread roll into slices and dip into tepid water. Press out excess water. Peel the onion, finely dice and sauté on butter. Add the bread roll, the minced meat, 2 eggs and the cream. Mix and season with salt, pepper, ground paprika and Worcester sauce.

Then salt, pepper and wrap the cooled down meat in the prepared meat mixture. Place the meat in a cool location. Spread the Danish pastry dough and wrap the cool meat into it. Place the meat wrapped in the Danish pastry dough onto baking paper so that the joint in the dough points downwards. Wipe the dough with whipped yolk. Move the meat together with the baking paper on to the low rack and bake in the preheated oven at 200 °C for approximately 10 minutes, until the dough rises. Then lower the temperature to 160 °C and bake for a further 50 minutes.

Once the meat cools down, cut it into slices and serve with a vegetable side dish.

Filled veal breast

1.5 kg of veal breast, 2 tablespoons of butter, salt

Stuffing:

1 tablespoon of butter, ½ a cup of finely diced onion, 1 tablespoon of lemon juice, 1 teaspoon of grated lemon peel, 1 cup of mushroom slices, 2 cups of diced white bread, 1 whipped egg, salt and pepper according to taste

First prepare the stuffing. On a preheated pan melt some butter. Sauté the onion on the butter and add the lemon juice, grated lemon peel and mushrooms. Fry on mild heat for 3 to 4 minutes. Place this mixture into a larger bowl. Add the diced white bread and whipped egg. Flavour with salt and pepper and stir everything together well.

Wash the meat under running water and dry using a wiping cloth. Using a sharp knife cut a pocket into the meat. Salt the meat inside and out. Fill the pocket with the prepared stuffing. Use toothpicks to close the pocket opening. Smear butter on the surface of the pocket and place the pocket on the low rack. Preheat the oven and bake the meat for 20 minutes at a temperature of 160 °C. After 20 minutes turn the pocket over and smear it with butter. Bake for another 40 minutes until the meat becomes tender.

Cut the pocket into slices and serve with the baked juices.

Chicken wings baked in honey

1 kg chicken wings, 2 tablespoons of honey, 2 tablespoons of tomato paste

Marinade:

3 tablespoons of lemon juice, 3 tablespoons of soy sauce, 1 teaspoon of ground ginger

Wash the wings under running water, dry using a wiping cloth and place in the bowl. Prepare the marinade by mixing the lemon juice, soy sauce and ginger. Pour the marinade over the wings and leave them in the marinade for 3 to 4 hours, turning them over every once in a while. Remove 2 tablespoons of the marinade and mix it with the honey and the tomato paste.

Place the wings on the high rack and bake for 10 minutes at a temperature of 160 °C. After 10 minutes take the wings out and smear with the mixture of the marinade, honey and tomato paste. Put the wings back on the rack and bake for another 5 minutes. Take them out again and smear with the mixture. Put them back and bake for another 5 minutes.

Roast chicken

1 whole chicken without offals, 1 small onion, 1 tablespoon of butter, ½ a cup of mushrooms, 1½ cups of diced bread rolls, 1 teaspoon of grated lemon peel, 1 tablespoon of chopped chives, 1 tablespoon of dried marjoram, 1 whipped egg, 1½ cups of chicken broth (or chicken bouillon), a pinch of nutmeg, garlic, salt and pepper for taste.

Wash the chicken under running water and dry using a wiping cloth. Peel the onion and chop it fine. Heat the butter on a pan and sauté the onion on it. Add mushrooms and fry for approximately 1 minute. Allow it to cool down and mix in bread roll cubes, chives, lemon peel, marjoram, nutmeg, whipped egg and flavour with salt and pepper. Fill the chicken with this mixture and close the opening using toothpicks. Smear the chicken with butter and salt and place on the low rack. Bake for 20 minutes at a temperature of 160 °C. Then turn the chicken over, smear with butter and bake for another 20 minutes or until is baked to a golden brown colour.

Juice:

Take the baking juice from the bottom of the bowl. Add a tablespoon of fine flour, heat it up on mild heat and mix until smooth. Slowly add 1½ cups of chicken broth (or chicken bouillon). Cook for a short time on mild heat. Flavour with salt and pepper.

Baked vegetables

Choose some vegetables, cut into same size cubes, add 2 to 3 tablespoons of cooking vegetable oil, garlic and flavour with salt and pepper

Wash the vegetables and peel if necessary. Cut the vegetables up into same size cubes and place in the bowl. Add 2 to 3 tablespoons of vegetable oil and garlic and flavour with salt and pepper. Mix everything well. Preheat the oven. Arrange the vegetables on the high rack and bake for 30 to 45 minutes at a temperature of 180 °C. Leave a space between the individual vegetable pieces so that air circulation is not impeded. The actual cooking time depends on the type of vegetables and the size of the pieces.

Potatoes baked in aluminium foil

Medium-sized potatoes (2 pcs per person), butter, garlic, salt and pepper for flavouring

Wash and clean the potatoes. Place them on the aluminium foil. Smear with butter and crushed garlic and flavour with salt and pepper. Wrap each potato independently into the aluminium foil.



Tip:

Potatoes prepared in this way can be baked together with the meat.

Place the potatoes on the high rack and bake for approximately 45 minutes at a temperature of 190 °C. To check that the potatoes are soft, pierce them with a fork. If necessary extend the baking time. Serve with sour cream poured over them, sprinkled with chives or grated cheese.

Cauliflower au gratin

1 medium-sized cauliflower, 60 g of butter, 2 tablespoons of fine flour, 250 g of cream, 150 g of grated cheddar cheese, salt and pepper for flavouring

Wash, clean and divide the cauliflower into larger florets. Boil the florets for a short time in salty water so that they are not too soft. Let them drip off after taking them out.

Heat up $\frac{2}{3}$ of the butter on a pan. Add flour and mix until smooth. Add the cream and the grated cheese (leave 2 tablespoons for sprinkling) and cook at mild heat for 1 minute. Flavour with salt and pepper.

Place the cauliflower florets into a baking dish and pour the prepared sauce over them. Sprinkle the top with the remaining cheese and add pieces of butter. Bake in the oven preheated to 150 °C for approximately 15 to 20 minutes or until the surface is a golden brown colour.

INSTRUCTIONS AND INFORMATION REGARDING THE DISPOSAL OF USED PACKAGING MATERIALS

Dispose of packaging material at a public waste disposal site.

DISPOSAL OF USED ELECTRICAL AND ELECTRONIC EQUIPMENT



The meaning of the symbol on the product, its accessory or packaging indicates that this product shall not be treated as household waste. Please, dispose of this product at your applicable collection point for the recycling of electrical & electronic equipment waste. Alternatively in some states of the European Union or other European states you may return your products to your local retailer when buying an equivalent new product. The correct disposal of this product will help save valuable natural resources and help in preventing the potential negative impact on the environment and human health, which could be caused as a result of improper liquidation of waste. Please ask your local authorities or the nearest waste collection centre for further details. The improper disposal of this type of waste may fall subject to national regulations for fines.

For business entities in the European Union

If you wish to dispose of an electrical or electronic device, request the necessary information from your seller or supplier.

Disposal in other countries outside the European Union

If you wish to dispose of this product, request the necessary information about the correct disposal method from local government departments or from your seller.



This product meets all the basic EU regulation requirements that relate to it.

Halogen Oven

SMH 330