



## 1/2 TON JACK TRANSMISSION

ITEM: 56027



### OWNER'S MANUAL AND SAFETY INSTRUCTIONS

SAVE THIS MANUAL: KEEP THIS MANUAL FOR SAFETY WARNINGS, PRECAUTIONS, ASSEMBLY, OPERATING, INSPECTION, MAINTENANCE AND CLEANING PROCEDURES. WRITE THE PRODUCT'S SERIAL NUMBER ON THE BACK OF THE MANUAL NEAR THE ASSEMBLY DIAGRAM (OR MONTH AND YEAR OF PURCHASE IF PRODUCT HAS NO NUMBER).

FOR QUESTIONS PLEASE CALL OUR CUSTOMER SUPPORT: (909) 628 4900 MON-FRI 9AM TO 3PM PST





## GENERAL SAFETY WARNINGS

Read all safety warnings and instructions. Failure to follow the warnings and instructions may result in electric shock, fire and/or serious injury. Save all warnings and instructions for future reference.

## SAFETY

---

The warnings, precautions, and instructions discussed in this instruction manual cannot cover all possible conditions and situations that may occur. It must be understood by the operator that common sense and caution are factors which cannot be built into this product, but must be supplied by the operator. Read carefully and understand all ASSEMBLY AND OPERATION INSTRUCTIONS before operating. Failure to follow the safety rules and other basic safety precautions may result in serious personal injury.

- **Read and understand all instructions.** Failure to follow all instructions may result in serious injury or property damage.
- **DO NOT** allow persons to operate or assemble the product until they have read this manual and have developed a thorough understanding of how it works.
- Store idle equipment. When not in use, tools must be stored in a dry location to inhibit rust. ALWAYS lock up tools and keep out of the reach of children.
- **Inspect the work area before each use.** Keep work area clean, dry, free of clutter, and well-lit. Cluttered, wet, or dark work areas can result in injury. Using the product in confined work areas may put you dangerously close to cutting tools and rotating parts.
- **Dress properly. DO NOT** wear loose clothing, dangling objects, or jewellery. Keep your hair, clothing and gloves away from moving parts. Loose clothes, jewellery, or long hair can be caught in moving parts.
- **Check for damaged parts before each use.** Carefully check that the product will operate properly and perform its intended function. Replace damaged or worn parts immediately. Never operate the product with a damaged part.
- **Keep children and bystanders away from the work area while operating the tool. DO NOT** allow children to handle the product.
- Stay alert, watch what you are doing, and use common sense when operating the tool. **DO NOT** use the tool while you are tired or under the influence of drugs, alcohol, or medication.
- **DO NOT overreach.** Keep proper footing and balance at all times.
- **Wear the proper personal protective equipment when necessary.** Use ANSI Z87.1 compliant safety goggles (not safety glasses) with side shields, or when needed, a face shield.
- **DO NOT** operate the tool if under the influence of drugs or alcohol. read the warning labels to determine if your judgement. If there is any doubt, **DO NOT** operate the tool.
- Use the right tool for the job. **DO NOT** attempt to force a small tool to do the work of a larger tool. **DO NOT** modify this tool or use the tool for a purpose it was not intended.
- **Maintain tools with care.** Keep tools sharp and clean for better performance. Follow instructions for lubricating and changing accessories. The handles must be kept clean, dry and free of oil and grease.

# IMPORTANT SAFETY INFORMATION

- When servicing, use only identical replacement parts.
- **DO NOT** overload this equipment. Know the weight of the item being lifted.
- Place the jack correctly. Only use this tool on a surface that is stable, level, clean and dry and capable of sustaining the load.
- Stabilize the load. Ensure that the load remains stable at all times. **DO NOT** move the load while it is on the jack.
- When lifting a vehicle, apply the emergency break and block all the wheels.
- Stabilize the load. Ensure that the load remains stable at all times. **DO NOT** move the load while it is on the jack.
- Observe work area conditions. **DO NOT** use machines or power tools in damp or wet locations.
- **DO NOT** force the tool. It will do the job better and safer at the rate for which it was intended. **DO NOT** use inappropriate attachments in an attempt to exceed the tools capacity.

 **SAVE THESE WARNINGS**

# PARTS DIAGRAM

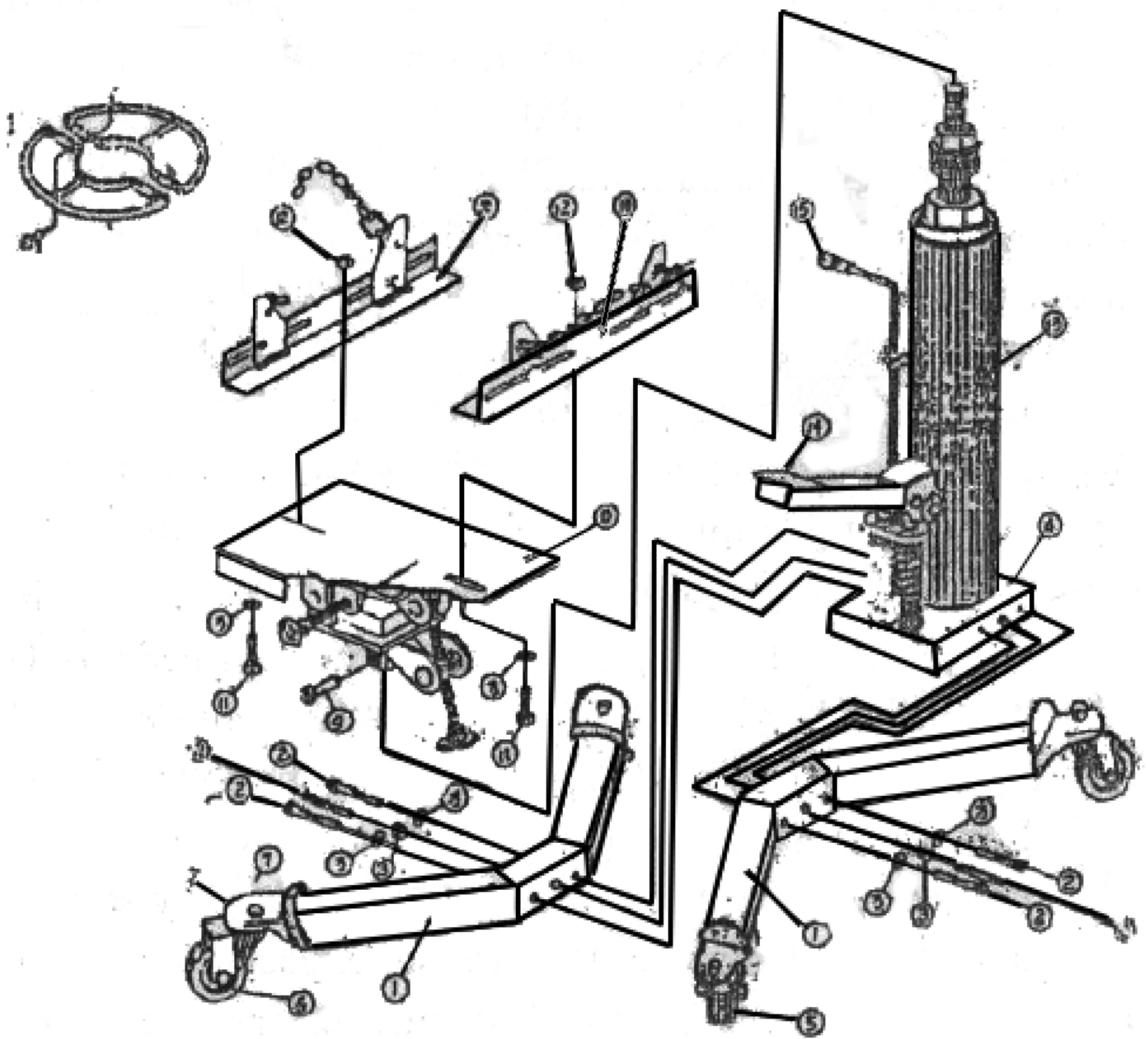

## PARTS LIST

- |                    |                         |                       |
|--------------------|-------------------------|-----------------------|
| 1. Wheel Stand x2  | 7. Nut M12 x4           | 13. Nut (M10) x6      |
| 2. Bolt (12*65) x6 | 8. Aadle Unit x1        | 14. Air Vent Valve x1 |
| 3. Washer x6       | 9. Round Handle Assy x1 | 15. Foot Pedal x1     |
| 4. Power Unit x1   | 10. Bolt (M8*16) x1     | 16. Release Handle x1 |
| 5. Castor Wheel x4 | 11. Cramp x2            | 17. Washer x6         |
| 6. Washer x4       | 12. Bolt (M10*25) x6    |                       |

## PARTS LIST

For transportation, the jack is separated into three components. When used for the first time, assemble according to the NO. I drawing.

1. Wheel stand: Connect the two wheel stands CD with the power unit by inserting the in six-angled bole (2) (M12:X70) . and washer into the proper hole on the power unit and tighten the screw. Assembling four castor wheels together with spring washer on the four feet of the wheel stand CD and tighten the nuts.
2. Make the first part of piston onto the hole of the saddle unit at the proper position tighten the Screw (M8)
3. Fasten the two cramps with bolt (II) (M12x25) and washer to the Nut (12) (M12) on the saddle unit and colsen the screw, the distance between the two cramps can be adjusted if needed.
4. Change the air vent valve (13) with a hole in the centre instead of the one without a bole.

## OPERATION

### 1. Raising the saddle

Tighten the release valve handle (15) by turning in a clockwise direction and operate the foot pedal (14) if by hand, place the handle in the foot operated handle sleeve, operate the handle up and town.

### 2. Lowering the saddle

For safety, turn the release valve handle very slowly in counter-clockwise. Be sure not exceed 25 mm per second. If it lowers too fast, turn the release valve handle clockwise.

## TAKE NOTE

1. Be sure not exceed the rated capacity 0.5T.
2. Be sure to load firmly on centre of the Transmission jack. If not, adjust the handle to close it.
3. After. putting the load on it, use safety chain.
4. When lifting the load □t, use sa□ety chain.
5. There must be enough oil in the cylinder so that the cylinder can operated regularly.
6. When remove the transmission jack, the saddle must be at the lowest position.
7. Keep the removal parts oiled, to avoid rusted.

# DISCLAIMER

## PLEASE READ THE FOLLOWING CAREFULLY

THE MANUFACTURER AND/OR DISTRIBUTOR HAS PROVIDED THE PARTS LIST AND ASSEMBLY DIAGRAM IN THIS MANUAL AS A REFERENCE TOOL ONLY. NEITHER THE MANUFACTURER OR DISTRIBUTOR MAKES ANY REPRESENTATION OR WARRANTY OF ANY KIND TO THE BUYER THAT HE OR SHE IS QUALIFIED TO MAKE ANY REPAIRS TO THE PRODUCT, OR THAT HE OR SHE IS QUALIFIED TO REPLACE ANY PARTS OF THE PRODUCT. IN FACT, THE MANUFACTURER AND/OR DISTRIBUTOR EXPRESSLY STATES THAT ALL REPAIRS AND PARTS REPLACEMENTS SHOULD BE UNDERTAKEN BY CERTIFIED AND LICENSED TECHNICIANS, AND NOT BY THE BUYER. THE BUYER ASSUMES ALL RISK AND LIABILITY ARISING OUT OF HIS OR HER REPAIRS TO THE ORIGINAL PRODUCT OR REPLACEMENT PARTS THERETO, OR ARISING OUT OF HIS OR HER INSTALLATION OF REPLACEMENT PARTS THERETO.

**Record Product's Serial Number Here:** \_\_\_\_\_

**Note:** If product has no serial number, record month and year of purchase instead.

**Note:** Some parts are listed and shown for illustration purposes only and are not available individually as replacement parts.



**SAVE THESE INSTRUCTIONS.**

### Questions, issues or missing parts?

Before returning to your retailer, our customer service team is here to help.



Call Us: 909.628.4900

Email Us: [info@starktoolsusa.com](mailto:info@starktoolsusa.com)

Hours of Operation: 9am - 3pm PST Monday - Friday

PRODUCT MADE IN CHINA