

Electric Heat Pump Water Heater

Compress 3000 DW F00

HP 270-2E 0 F00V/S...



BOSCH

Installation instructions



Please read the installation instructions before installing the appliance!
Please read the operating instructions before commissioning the appliance!



Please observe the safety instructions in the operating instructions!
The installation location must meet the requirements for sufficient ventilation!



Installation must only be carried out by an authorised contractor!

Index	
1	Key to symbols and safety instructions 3
1.1	Key to symbols 3
1.2	Safety information 3
2	Standard delivery 6
3	Appliance details 7
3.1	Overview 7
3.2	Features and safety devices 7
3.3	Specification tables 9
3.4	Storing and transportation 10
3.4.1	Transport using a forklift 10
3.5	Operational principle (brief overview of modes) 12
3.6	Dimensions 14
3.7	Clearances 15
4	Installation instructions 16
4.1	Tools required 16
4.2	Location requirements 16
4.3	Secure the appliance 17
4.4	Water piping 17
4.4.1	Inlet - Outlet connections 17
4.4.2	Condensate Drain Tubes (not supplied with the appliance) 17
4.4.3	PTR Valve (supplied with the appliance) .. 18
4.4.4	Temperature mixing device (not supplied with the appliance) 19
4.4.5	Pressure limiting valve (not supplied with the appliance) 19
4.4.6	Expansion control valve (not supplied with the appliance) 19
4.5	Electric requirements 19
4.6	Installation with connectivity to Bosch photovoltaic systems 20
4.7	Installation configurations 21
4.7.1	Ecological ambient heat recovery 21
4.8	Insulation blanket 21
4.9	Fill the water storage tank 22
4.9.1	Water characteristics 23
4.10	Installation checklist 23
4.11	What to expect from a "normal startup" ... 25
4.12	Off-peak compatibility 25
4.13	Demand response 25
5	Appliance status information 26
5.1	Safety warnings 26
5.2	Working display 27
5.3	Operation programs 27
5.4	Setting the domestic hot water temperature . 27
5.5	Main menu 28
5.6	"Prog" submenu - Operating programs ... 28
5.6.1	"Manual" operating mode 28
5.6.2	"P1", "P2" and "P3" operating modes 28
5.6.3	"Hol" mode 28
5.6.4	"OFF" operating mode 29
5.7	"Set" submenu - Settings 29
5.7.1	Date - Setting the temperature unit, date, time and day of the week 29
5.7.2	Prog - Timetable operating programing ... 30
5.7.3	„Leg“ function - automatic thermal disinfection 33
5.7.4	„PLUS“ - enhanced comfort function 34
5.7.5	„HEA“ - heating by electrical assistance .. 35
5.7.6	„Purg“ function - purge 35
5.7.7	“PHot” - photovoltaic 35
5.7.8	„Fset“ function - factory resetting 37
5.8	„Info“ - information 38
5.9	„Sft“ - software version 38
5.10	One shot boost and auto boost at negative temperatures 39
5.11	Troubleshooting 40
5.12	Factory configurations 40
5.13	Controls 41
6	Maintenance and repair 42
6.1	Periodic Inspection 42
6.2	Temperature and pressure relief valve (PTR Valve) 42
6.3	Flushing tank 42
6.4	Draining the Water Heater 42
6.5	Vacation and Extended Shutdown 43
6.6	Clearing the Condensation Drain Tubes .. 43
6.7	Refrigerant circuit 43
6.8	Anode Rod servicing 43
6.9	Checking/replacing the magnesium anode 43
6.10	Service menu 44
7	Display 47
7.1	Fault display 47
7.2	Displays 47
8	Electrical diagram 49

9 Environmental protection 50

10 Warranty details 51

1 Key to symbols and safety instructions

1.1 Key to symbols

Warnings



Warnings in this document are identified by a warning triangle printed against a grey background.

Keywords at the start of a warning indicate the type and seriousness of the ensuing risk if measures to prevent the risk are not taken.

The following keywords are defined and can be used in this document:

- **NOTICE** indicates a situation that could result in damage to property or equipment.
- **CAUTION** indicates a situation that could result in minor to medium injury.
- **WARNING** indicates a situation that could result in severe injury or death.
- **DANGER** indicates a situation that will result in severe injury or death.

Important information



This symbol indicates important information where there is no risk to people or property.

Additional symbols

Symbol	Explanation
▶	Step in an action sequence
→	Cross-reference to another part of the document
•	List entry
–	List entry (second level)

Table 1

1.2 Safety information

„Water“ safety warnings



WARNING:

This water heater is not suitable for pool heating.



WARNING:

The appliance should be located in an area where leakage of the heater or connections will not result in damage to the area adjacent to the appliance or to lower floors of the structure. When such locations cannot be avoided, it is recommended that a suitable drain pan, adequately drained, be installed under the appliance.



WARNING:

If a water heater is installed in a closed water supply system, such as one having a backflow preventer in the cold water supply line, means shall be provided to control thermal expansion. Contact the water supplier or local plumber on how to control this situation.



WARNING:

Precautions must be taken prior to manually operating the relief valve to avoid contact with hot water coming out of the relief valve and to prevent water damage.



WARNING:

If a relief valve discharges periodically, this may be due to thermal expansion in a closed water supply system. Contact the water supplier or local plumber on how to correct this situation. Do not plug the relief valve.



WARNING:

The temperature pressure relief valve should be checked for performance every six months or replaced at intervals not exceeding 3 years, or more frequently in areas where there is a high incidence of water deposits.

Refrigerant

- ▶ Please observe the relevant environmental regulations when using and reusing refrigerant. Do not allow refrigerant to be discharged into the environment. Use the refrigerant R134a. It is non-flammable and does not have a destructive impact on the ozone layer.
- ▶ Before working on parts of the refrigerant circuit, remove the refrigerant to ensure work safety.

Use HFC-134a and PAG-OIL for maintenance purposes. It contains fluorinated greenhouse gas and is rated with a greenhouse potential of 1300 in the Kyoto Protocol.

„Electric“ safety warnings



WARNING:

This water heater contains electronic equipment and 500V insulation tests must only be conducted between active and earth and between neutral and earth. **An active to neutral test WILL damage the electronics.**



WARNING:

All electrical work and fixed wiring must be carried out by a qualified person and in accordance with the Wiring Rules AS/NZS 3000 and local authority requirements.



DANGER:

Shock hazard: line voltage is present. Before servicing the water heater, please cut the power supply. Failure to do so could result in severe personal injury or death.



CAUTION:

Label all wires prior to disconnection when servicing controls. Wiring errors can result in improper and dangerous operation. Verify proper operation after servicing.



WARNING:

Do not turn power off to the appliance if cold weather is expected as components may be damaged by freezing. If power needs to be turned off or power failure occurs and freezing conditions are expected, water should be drained from the appliance.

„General“ safety warnings

Do not store or use gasoline or other flammable, combustible or corrosive vapors and liquids in the vicinity of this or any other appliance.



WARNING:

Do not operate this system before reading the manual.



WARNING:

This appliance must be installed, commissioned and serviced by an authorised person in accordance with all applicable local rules and regulations.



WARNING:

Keep appliance area clear and free from combustible materials, gasoline and other flammable vapors and liquids.

For your safety



WARNING:

The power supply to the appliance must not be activated until the system is filled with water.



WARNING:

To meet the requirements of the National Plumbing Standard, the appliance runs a weekly legionella disinfection cycle automatically.



WARNING:

Water temperatures over 50 °C can cause severe scalds. Local regulations and/or the requirements of AS/NZS 3500.4 must be considered regarding the temperature limitations of hot water used primarily for personal hygiene.

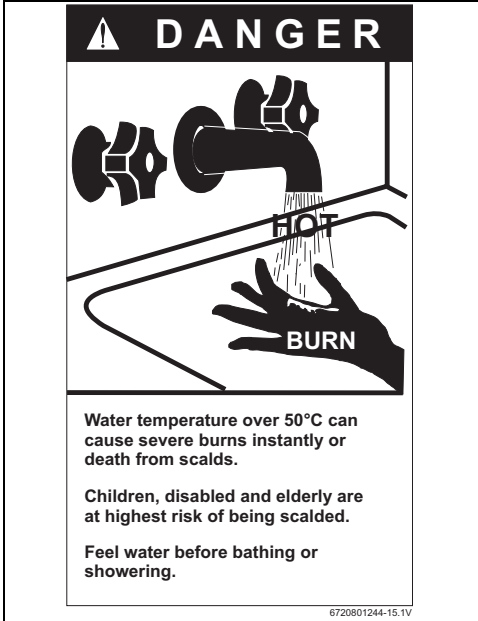

Fig. 1

To prevent serious injury, unit damage or damage to other property, please use the unit properly. Read this manual carefully and understand the following information correctly.



WARNING:

This appliance is not intended for use by persons, including children, with reduced physical, sensory or mental capabilities, or lack of experience and knowledge, unless they have been given supervision or instruction concerning use of the appliance by a person responsible for their safety.



WARNING:

Installation requirements are described in chapter 4. The water heater must be installed by an authorised person and the installation must comply with Standards AS/ NZS 3500.4, AS/NZS 3000 and all local codes and regulatory authority requirements. In New Zealand, the installation must conform with Clause G12 of the New Zealand Building Code.



WARNING:

A wrong operation may lead to death or serious injury to people.

High temperature water increases the risk of scald injury

This water heater can heat up water to temperatures which can cause scalding. Always feel the water temperature before use, either before having a shower or when filling a bath tub to ensure it will not cause scald injuries.

We recommend, and it may also be required by regulations that an approved temperature limiting device is fitted into the hot water pipe connected to sanitary outlets (i.e. bathroom and ensuite). This will keep the water temperature below 50 °C at these outlets. The risk of scald injury will be reduced and still allow hotter water to the kitchen and laundry.

Notice to Victorian Customers from the Victorian Plumbing Industry Commission.

This water heater must be installed by a licensed person as required by the Victorian Building Act 1993. Only a licensed professional will give you a Compliance Certificate, showing that the work complies with all the relevant standards. Only a licensed person will have insurance protecting their workmanship.

Make sure you use a licensed person to install this water heater and ask for your Compliance Certificate.

Every care has been taken to ensure accuracy in preparing this document.



No liability can be accepted for any consequences, which may arise as a result of its application.

2 Standard delivery

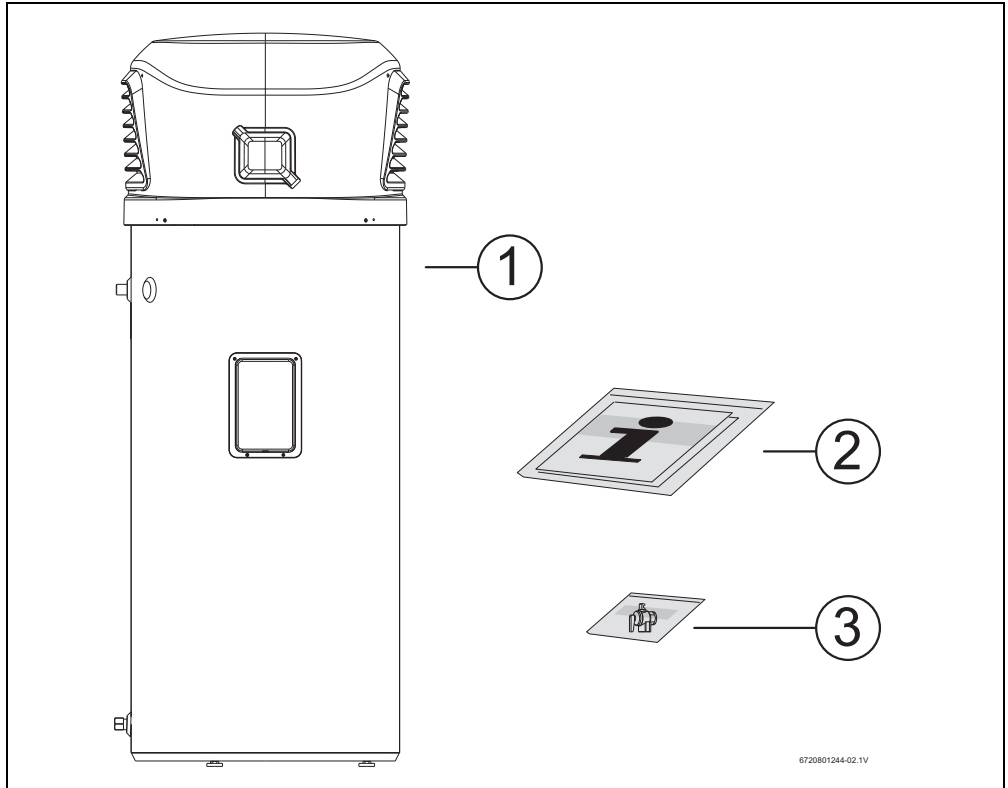

Fig. 2

- [1] Heat pump
- [2] Set of printed documents for the appliance
- [3] PTR valve (located)

3 Appliance details

3.1 Overview

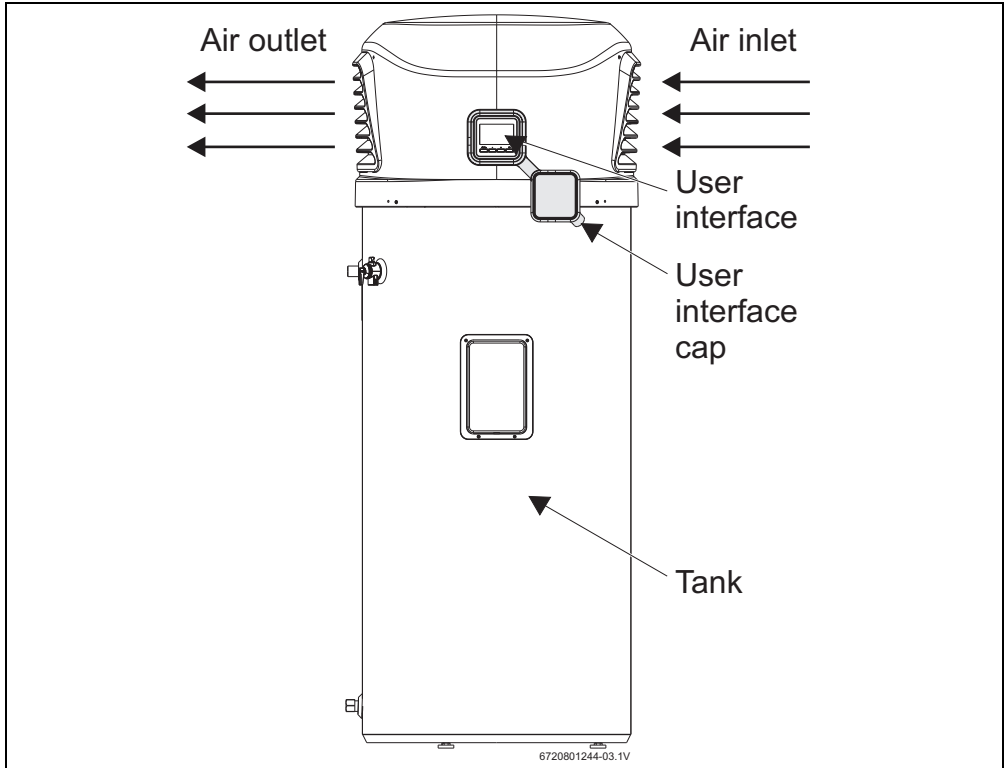

Fig. 3 Appliance overview

3.2 Features and safety devices

Easy to operate and environmentally friendly

The heat pump has user interface with easy use menu keys for programming. The heat pump is also environmentally friendly as it transfers heat from the surrounding area into the water.

Heating capacity

The unit absorbs ambient energy and releases the heat into the water stored in the tank. If the ambient temperature is low, the heating capacity of the heat pump will be reduced, but you can still rely on the electric element for backup: the electrical element will automatically turn on below 0 °C to assist the heat pump module.

Thermal Cut Out (TCOs)

The water heater is equipped with one thermal cut-out (TCO) located near the heating element. If for any reason the water temperature becomes excessively high, the thermal cut-out (TCO) cuts the power circuit to the heating element. Once activated, the TCO must be reset manually. Resetting of the temperature limiting control must be done by a qualified service technician.



CAUTION:

The cause of the high temperature condition must be investigated by a qualified service technician and corrective actions must be taken before placing the water heater in service again.

Defrosting

During the heating, when the air temperature is between $-7\text{ }^{\circ}\text{C}$ and $10\text{ }^{\circ}\text{C}$ frost may be formed at the evaporator, thus blocking the air flow and reducing the heat transfer efficiency.

To avoid this occurring, the appliance will automatically defrost the evaporator by injecting hot refrigerant gas into the evaporator circuit via a bypass valve. The control of this functionality relies on the temperature readings of the air and fins sensors.

The defrost cycles last typically between 5 and 15 minutes and their frequency depends on the environmental conditions (air temperature and relative humidity).

During the defrost cycles only the compressor runs. After the evaporator defrost is concluded the unit returns to normal operation.

In case the air flow is restraint, for instance due to high wind intensity at the air outlet, the frequency of defrost cycles might increase.

Working condition

The appliance is designed to operate with best efficiency when the air temperature is between $-7\text{ }^{\circ}\text{C}$ and $+40\text{ }^{\circ}\text{C}$.

Care should be taken to feed the unit only with potable water (→ section 4.9.1). Do not use untreated water from lakes, rivers or groundwater!

Overheating protection

In case the water temperature near the electrical heating element reaches $84\pm 4\text{ }^{\circ}\text{C}$ the power to the electrical element is cut off by a thermostat mounted together with the electrical heater and will require a manual reset.

Water temperature and pressure protection

The unit is supplied with a PTR valve for your safety (supplied accessory). If the tank pressure reaches 1000kPa or the temperature reaches $99\text{ }^{\circ}\text{C}$, the PTR valve will open automatically to allow the pressure or temperature to decrease to safe values.

The warranty can become void if relief valves or other safety devices are tampered with or if the installation is not in accordance with the instructions in this manual.

Mains Pressure

This water heater is designed for direct connection to mains water supply. In case the mains supply pressure exceeds 800kPa, a pressure limiting valve must be installed (→section 4.4.4). A minimum water supply pressure of 200kPa is required to assure the effective operation of this water heater.

3.3 Specification tables

Model		HP 270-2E 0 FOOV/S	
Running ambient air temp.		°C	-7 °C/+40 °C
Outlet Water Temp.		°C	setpoint ± 1 °C
Minimum Inlet Water Temp.		°C	3 °C
Maximum Inlet Water Temp.		°C	70 °C
Power supply		Ph-V-Hz	1ph / 230V-240V / 50 Hz
IP rating		IP	X4
Storage size		l	270
Water heating (HP cycle) ¹⁾	Heating capacity	kW	1.5
	Max. input	kW	0.6
	Max. current	A	2.6
Water heating (Full mode) ¹⁾	Heating capacity	kW	3.15
	Max. input	kW	2.25
	Max. current	A	9.8
COP ²⁾			3.3
Unit	Dimension (D×H)	mm	705 x 1840
	Packing (W×H×D)	mm	730 x 2004 x 730
	Net/gross weight	kg	113/128
Sound pressure level at 2 m		dB (A)	43
Refrigerant type/Mass		kg	R134a / 0.375
Max. refrigerant circuit pressure		kPa	2700
PTR valve setting ³⁾		kPa	1000
Throttling type		Thermal expansion valve	
System protection		High pressure limiter, Temperature limiter	
Compressor	Model	WHP01900	
	Type	Rotary	
	Brand	Highly	
	Input	W	700
Fan motor	Model	W1G230EB	
	Brand	EBM Papst	
	Input	W	28
	Speed	r/min	1500
Water connections	Water inlet	¾ BSP inch	
	Water outlet	¾ BSP inch	
	Max. water working pressure	kPa	1000
	PTR valve joint	½ BSP inch	
	Max inlet pressure	kPa	800
	Heat exchanger	Double wall plate heat exchanger	
Electric heating element	Rated power input at 230 V	kW	1.65
	Rated current at 230 V	A	7.2

Table 2

- 1) Air at 15 °C and voltage supply 230V
- 2) According to EN255-3 by using air at 20 °C, water inlet at 15 °C and factory settings
- 3) PTR valve power capacity: 10 kW

Operating ambient air temperature range:

Operating ambient temperature range of the heat pump cycle:
-7/ +40 °C.



The appliance can operate beyond the normal temperature range by using the electrical heater only.

The hot water recover rate is dependent on the ambient air temperature around the heat pump. The heat pump will produce more hot water in a warmer ambient air temperature.

The table below shows heat up times at different air temperatures.

Air Temp [°C]	Humidity [%]	Water inlet [°C]	Set Point [°C]	Heating Up time	Heat Up time w/ PLUS	COP N235	Water available at 40°C [dm ³]
-5	–	10	56	11h45± 0h20	11h45± 0h20		
1	90	10	56	17h30± 0h20	9h00± 1h00		335± 20
9	87	10	56	11h00± 0h20	7h00± 1h00	3.0	
15	70	15	56	8h00± 0h20	8h00± 0h20	3.3	
20	60	15	56	7h15± 0h15	7h15± 0h15		
32	60	15	56	5h15± 0h15	5h15± 0h15		

Table 3

3.4 Storing and transportation

As a rule, the unit is to be stored and/or transported in its original packaging, in upright position.

For transport over short distances (<500km), and provided that original packaging is kept and due care is taken, horizontal transportation is permitted. Nevertheless, an inclination angle of up to 90° must be ensured, for compressor lifetime assurance.

Both during transport and storage, ambient temperatures between -20 °C and +60 °C are permissible.



In case the unit has been horizontally transported to place, it must be positioned upright at least one hour before it can be turned on for the first time.

3.4.1 Transport using a forklift

When transported by a forklift, the unit must remain mounted in the base. The lifting rate should be kept to a minimum. Due to its top-heaviness, the unit must be secured to avoid tipping over. To prevent any damage, the unit must be placed on a level surface!

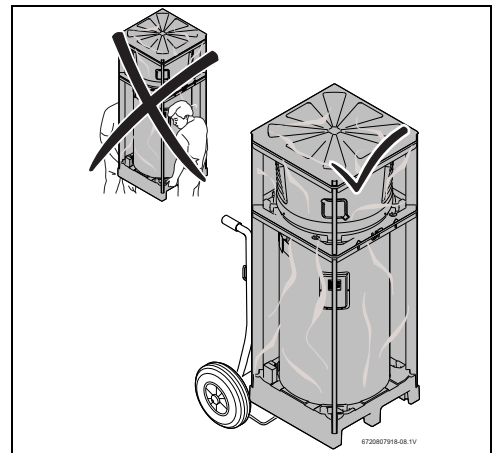

Fig. 4

**WARNING:**

Heat pumps are heavy and bulky. Australian States and Territories have a Principal Occupational Health and Safety (OH&S) Act which contains requirements relating to the handling of large, bulky or awkward items. Persons installing this heat pump system must be aware of their responsibilities and be adequately trained and qualified in accordance with local OH&S requirements.



WARNING: Transport damage!

- ▶ To avoid transport damage, wait until the appliance is at the installation location to remove the protective packaging.
- ▶ Use straps to prevent the appliance from becoming scratched.
- ▶ Use suitable means of transport to bring the appliance to the installation location (special car, pallet truck, etc).

3.5 Operational principle (brief overview of modes)

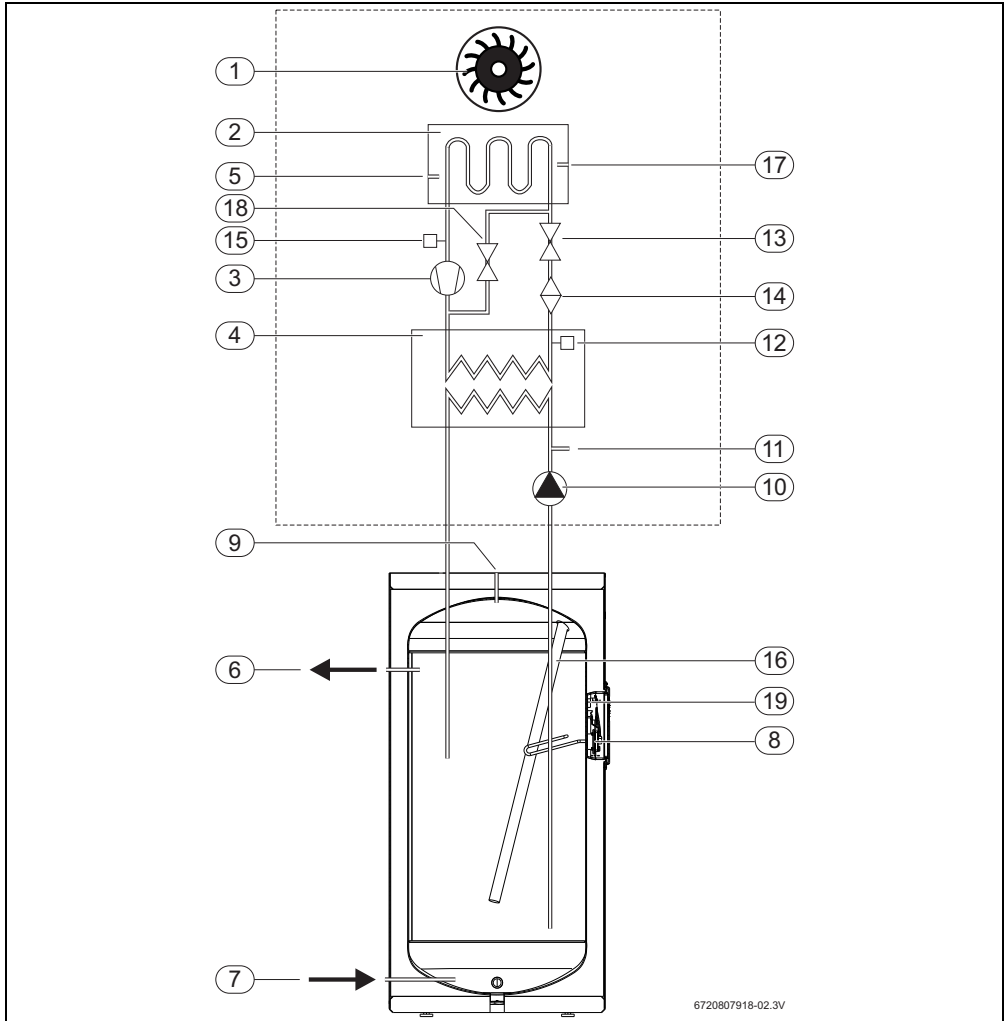

6720807918-02.3V

Fig. 5

- | | |
|--|--|
| [1] Air fan | [11] NTC temperature sensor (bottom of storage tank) |
| [2] Evaporator | [12] High-pressure pressure switch |
| [3] Compressor | [13] Expansion valve |
| [4] Condenser (gas/water heat exchanger) | [14] Filter dryer |
| [5] NTC temperature sensor (air inlet) | [15] Low-pressure pressure switch |
| [6] Hot water outlet | [16] Magnesium anode |
| [7] Cold water inlet | [17] Temperature sensor at the evaporator fins |
| [8] Electric heating element | [18] Solenoid Valve |
| [9] NTC temperature sensor (top of storage tank) | [19] Thermal Cut Out (TCO) |
| [10] DHW circulation pump | |

System basic theory

The refrigerant circuit is a closed system in which the refrigerant R134a circulates as a heat transfer medium.

The evaporator transfers the heat from the air to the refrigerant circuit, and the refrigerant evaporates into a gas.

The compressor compresses the refrigerant R134a, thus increasing its temperature.

Then, the heat is transferred via a heat exchanger, also referred to as a condenser, to the storage water tank. The refrigerant R134a condenses in the process.

R134a flows through the expansion valve in a liquid state with decreasing pressure, thus completing the cycle by being routed back to the evaporator.

Brief overview of the appliance operation

Between 0 °C and 40 °C air temperature the appliance only uses the economical heat pump cycle.

However, it is possible to manually turn on the electrical heater together with the heat pump when the air is above 0 °C (One shot boost). Once the set point is reached the boost is automatically switched off.

Between -7 °C and 0 °C the appliance automatically switches on the electrical heater together with heat pump cycle.

When the appliance has conditions to activate both electric and compressor "FULL" is displayed at the HMI, alternating with the top tank temperature.

When compressor and electrical heater are operating together, the upper part of the tank will rise much faster than the lower part, thus boosting the recovering time for the next hot water load. Hence, with "FULL" active, if the top temperature gets near the set point and the bottom is still rather at low temperature, the appliance, will automatically switch off the electrical heater and continues the heating with the heat pump cycle only but "FULL" will remain being displayed.

After the electrical heater is switched off, it is normal that the top temperature start to decrease slowly. Therefore, while rising the bottom temperature by only using the heat pump cycle and until the top temperature start to increase to set point, the electrical heater will be switched on as many times as required to keep the top near the set point.

Outside the air ambient range temperature, the unit operates by only using the electrical heater.

3.6 Dimensions

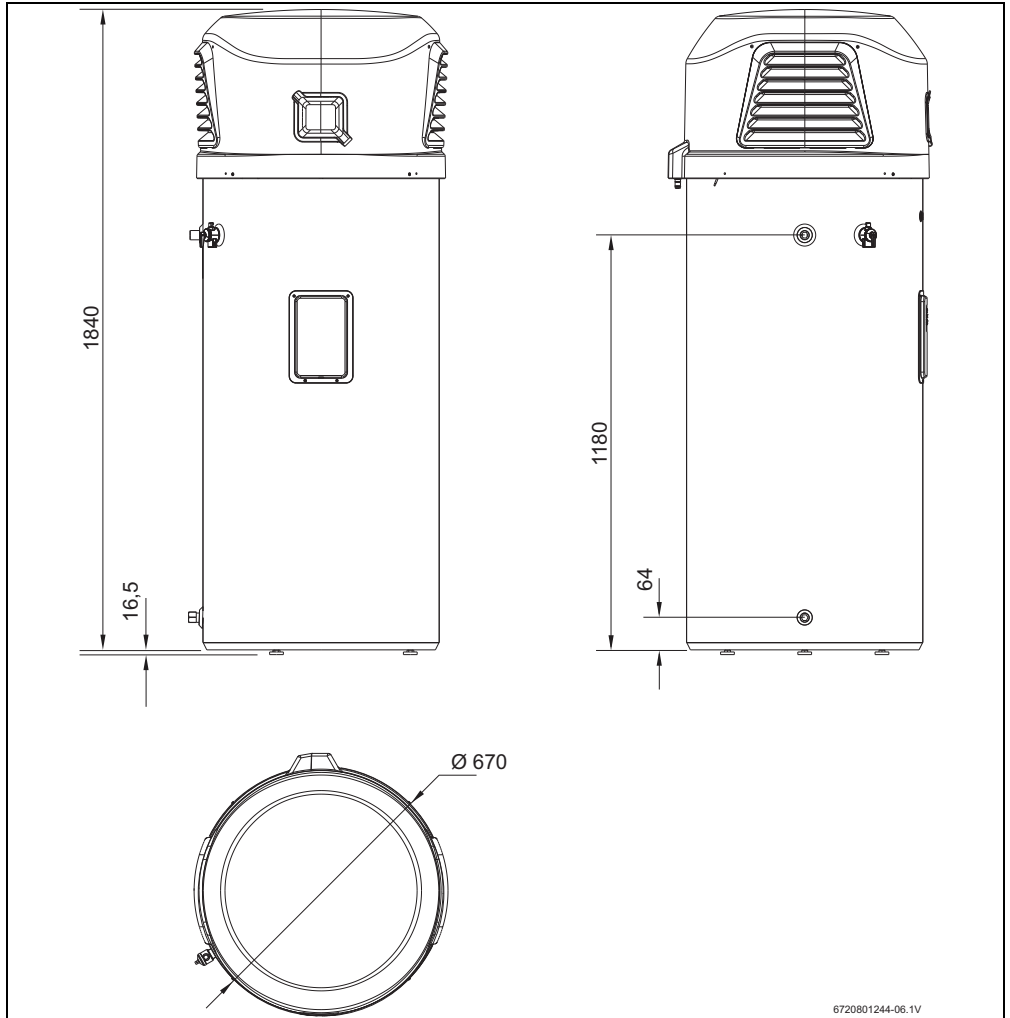

Fig. 6 Dimensions (in mm)

3.7 Clearances

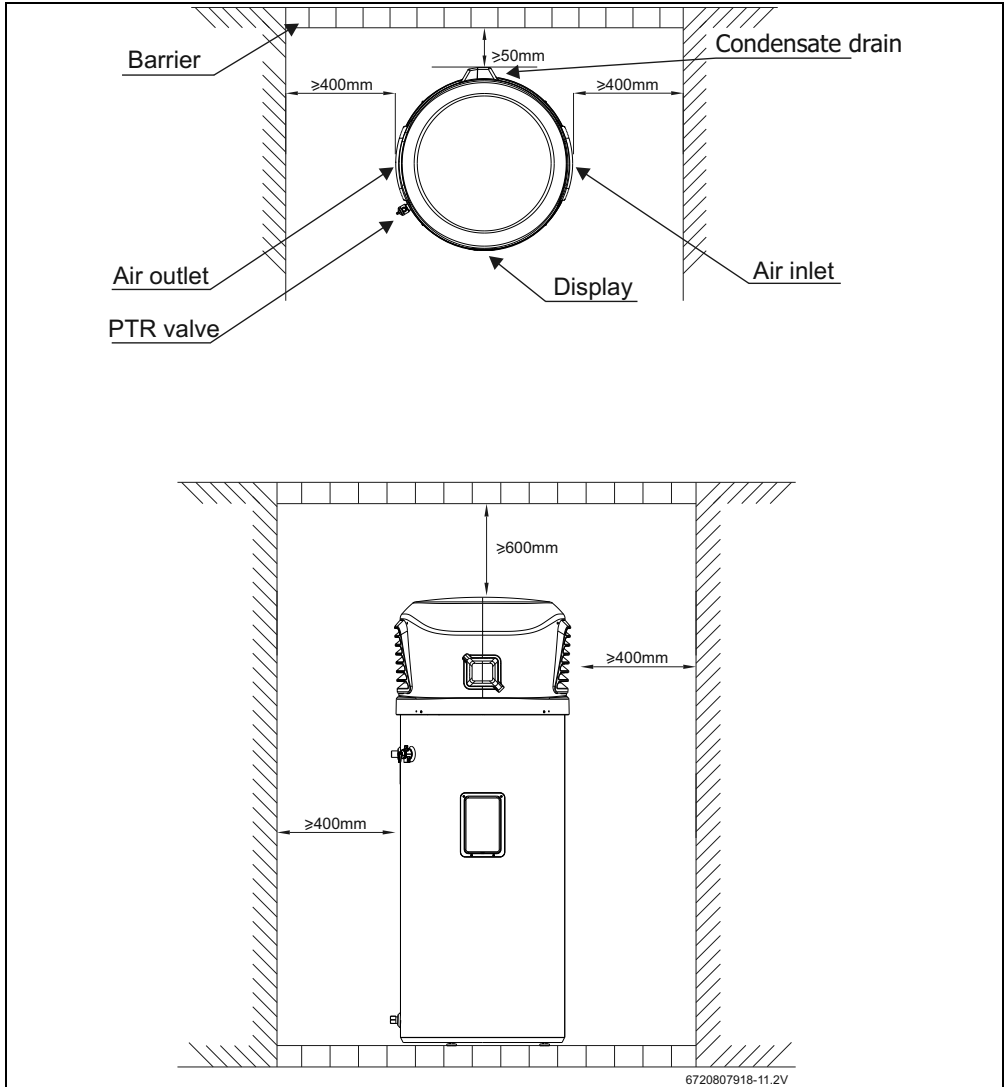

Fig. 7

**DANGER:**

The Temperature and Pressure relief valve delivered with the unit must be installed and must not be sealed or blocked. Failing to do so will result in a dangerous situation (→section 4.4.3).

4 Installation instructions

The manufacturer's warranty does not cover any damage or defect caused by improper installation, attachment or use of any type of accessories (other than those listed in this user manual) with this water heater. The use of unauthorized energy-saving devices may shorten the life of the water heater and may endanger life and cause property damage.

The manufacturer disclaims any responsibility for such loss or injury resulting from the use of such unauthorized devices.

4.1 Tools required

- Wrenches $\frac{3}{4}$ ", 10mm and 13mm.
- Philips screwdriver

4.2 Location requirements

Locate the water heater in a clean area as near as possible to the area of biggest hot water demand. Long uninsulated hot water lines can waste energy and water.

Note: Because this unit draws in ambient air to heat the water, when using the unit indoors, the room must be at least 3m x 3m x 2,5m (22,5 m³) or larger, and preferably vented. If the room is smaller, there must be a louvered door with minimum 500cm² venting area.

Place the water heater in such a way that clearance for proper servicing is considered (→section 3.7), namely for top cover removal, PTR valve access and anode rod removal and installation.

Remember you may need to remove the entire unit later for servicing.

The water heater and water lines should be protected from freezing temperatures and highly corrosive atmospheres.



CAUTION:

The water heater should not be located in an area where leakage of the tank or connection will result in damage to the area adjacent to it or to lower floors of the structure. In places where installation in such areas cannot be avoided, it is recommended that a suitable catch pan, adequately drained, be installed under the water heater (Fig. 8).



WARNING:

This water heater SHOULD NOT be installed in an area with a corrosive atmosphere where chemicals or flammable liquids are stored or where aerosol propellants are released. When using outdoors, because of natural air movement in a room or other enclosed space, these corrosive/flammable vapours can be carried from where they are being used or stored. Any electric arc drawn within the water heater's electronic controls can ignite these vapours causing an explosion or fire, which may result in severe burns or death to those in range, as well as property damage.

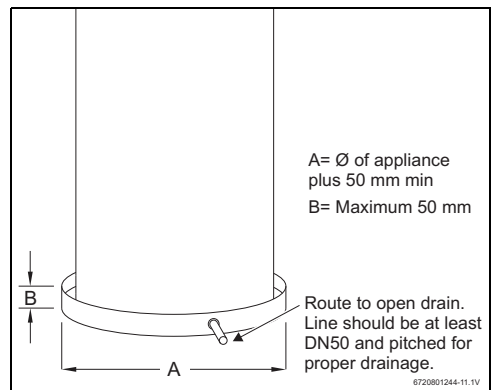

Fig. 8 Water heater support as specified in AS3500.4

NOTE: Auxiliary catch pan MUST conform to local codes. Catch Pan Kits are available from the store where the water heater was purchased, a builder store or any water heater distributor.

Recommendation

Even if this unit runs at very low noise levels, it is advisable to install it away from any living area windows.

- Check council laws for specific localized rules in relation to location requirements for this appliance.

Outdoor installation

This unit was designed both for outdoor and indoor installation. Proper clearances must be observed.

Local installation regulations

The installation must comply with the requirements of AS/NZS 3500.4 and AS/NZS 3000 standards and all additional local codes and regulatory authority requirements.

In New Zealand, the installation must comply with Clause G12 of the New Zealand Building Code.

All packaging materials must be removed from the water heater prior to its installation.

Required clearances

There must be a 60 cm vertical clearance, a 40 cm minimum clearance in front of the inlet/outlet grilles and 5 cm clearance from the back of the appliance (where the drain is) to any object (→ Fig. 7). This will ensure a proper air flow through the appliance and facilitate the service any time is needed.

Appliance orientation

In case of possible direct exposure to strong wind:

- ▶ Face the air outlet to the most protected area.

The direct incidence of strong wind in the outlet grille during long periods may affect the performance of the heat pump increasing the heating times and the frequency of defrost cycles. The use of the noise reduction mode is not recommended in case of moderate or strong wind.

Condensate drain

The unit has a condensate drain, therefore a drain must be available in close proximity to the unit. The drain must be no higher than 90 cm above the ground. Discharge point must comply with AS/NZS 3500.4.

If no drain is available, then a common condensate pump with a capacity no less than 4 liters/day must be purchased from a local builder and supply store and installed.

4.3 Secure the appliance

- ▶ Adjust the height of the adjustable feet to correctly align the appliance at the installation location.



To ensure faultless operation, the unit must be installed vertically, with a tilt no more than 1°, preferable in the direction of the condensate drain in order to favor the condensates drainage.



WARNING: Damage to external tank casing!
▶ Do not tilt more than 20° without packaging.

4.4 Water piping



WARNING:

All plumbing work must be carried out by a qualified professional and in accordance with the Plumbing Standard AS/NZS 3500.4 and local authority requirements.

4.4.1 Inlet - Outlet connections

Installation of the water inlet or outlet pipes: The water inlet and outlet thread are ¾ BSP (internal thread). Pipes must be heat-resistant, durable, and UV resistant (when doing outdoor installation).

Installation of the pipe for PTR valve: The specification of the valve connecting thread is ½ BSP (internal thread).



WARNING:

Care should be taken not to touch the pipe work as it may be hot.

All pipe work should be insulated with proper insulating material (weatherproof and UV resistant if exposed) to optimize energy efficiency. Water piping sizing should be performed in accordance with AS/NZS 3500.4.



CAUTION:

The temperature and pressure-relieve valve must be installed according to local code. Not doing so will cause damage to the appliance and damage to other property.

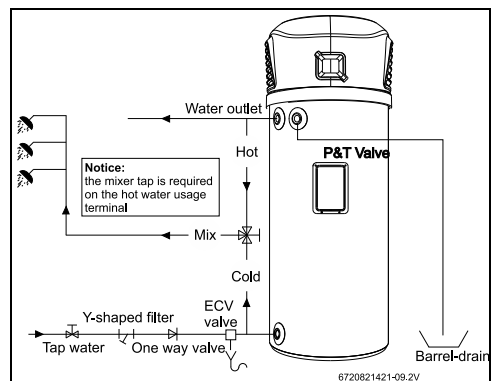

Fig. 9 Typical installation

4.4.2 Condensate Drain Tubes (not supplied with the appliance)

This unit has an integrated condensation tray. The water collected in the tray drains out of the tube coming off the back of the unit. It is important that a hose is attached to the drain port at the back of the unit.

- ▶ Attach one end of the condensate drain pipe (15mm inner diameter recommended) to the drain port at the back of the unit.
- ▶ Direct the other end to a drain in the floor or no higher than 8 cm above the ground in an outdoor installation. If such drain is unavailable, a condensate drain pump (not provided) must be purchased and installed.

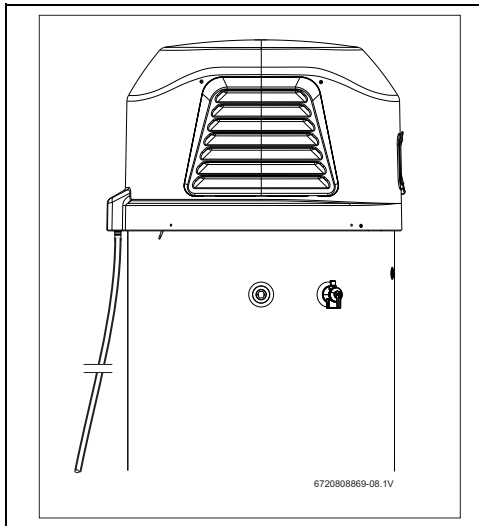

Fig. 10

4.4.3 PTR Valve (supplied with the appliance)

A temperature and pressure-relief valve is supplied and must be installed in the tank port marked for this purpose. No valve or accessory of any type should be installed between the relief valve and the tank. Please observe local codes for the correct installation of relief valves.



WARNING:

The pressure rating of the relief valve must not exceed 1000 kPa, the maximum working pressure of the water heater as marked on the rating plate.



WARNING:

Relief valve easing gear should be operated AT LEAST ONCE EVERY SIX MONTHS. If water does not discharge freely when the lever is operated, the valve should be checked by an authorized agent.



WARNING:

The relief valve and relief valve drain pipe must not be sealed or blocked. Small amounts of water may leak from relief valve during heating cycles.



WARNING:

Relief valves should be checked every six months, or replaced at intervals not exceeding 3 years or more frequently in areas where there is a high incidence of water deposits.



WARNING:

The function of the temperature and pressure relief valve once installed on this water heater is to discharge high temperature water under certain conditions. Therefore it is strongly recommended that the pipe work connected to the relief valve is able to withstand water temperatures exceeding 99 °C. Failure to follow this recommendation may result in a dangerous situation.

The kW rating of the relief valve must be higher than 6kW, to ensure that is always above the maximum output power of the water heater when operating with both electrical heater and heat pump and air at 40 °C. The supplied PTR valve complies with this by having a power capacity of 10kW.



WARNING:

Never block or seal the outlet of the PTR valve or it's drain for any reason. The warranty will be void if the relief valve or other safety devices are tampered with or if the installation is not in accordance with this manual.

Connect the outlet of the relief valve to a suitable open drain so that the discharge water cannot contact any electrical parts, persons or animals and to eliminate any other possible risks.

A drain line from a relief valve must comply with the requirements of AS/NZS 3500.4.



WARNING:

To reduce the risk of excessive pressures and temperatures in this water heater, install temperature and pressure protective equipment required by local codes and no less than a combination temperature and pressure relief valve certified by a nationally recognized testing laboratory that maintains periodic inspection of production of listed equipment or materials, as meeting the requirements of AS/NZS 3500.4, AS/NZS 3000 and all local codes and regulatory authority requirements.

Always use a valve of the same rated pressure and temperature as the PTR Valve supplied with the unit.

4.4.4 Temperature mixing device (not supplied with the appliance)



WARNING:

This water heater can heat water to temperatures which can cause scalding.

Bosch recommends the installation of a temperature limiting device between the water heater and the hot water outlets in a bathroom or similar usage point, in order to reduce the risk of scalding.

Additionally, a certified plumber may have the legal obligation to ensure the water heater installation meets the hot water delivery requirements listed in AS/NZS 3500.4.

4.4.5 Pressure limiting valve (not supplied with the appliance)

In installations where the mains water supply pressure exceeds that specified for this product (listed in chapter 3), an approved pressure limiting valve is required and must be fitted.

If the water heater is supplied with low pressure water, below the minimum working pressure specified for this product (listed in chapter 3), then a pressure pump should be installed in order to minimize the forming of air traps in the hydraulic circuit.

4.4.6 Expansion control valve (not supplied with the appliance)

Local regulations, a saturation index greater than +0.4 or in corrosive water areas where there are sufficient quantities of silica dissolved in the water may require the installation of an expansion control valve (ECV) in the cold water line, being the last valve installed prior to the water heater.

4.5 Electric requirements



CAUTION:

Do not incorrectly connect electrical connections. 230-240V AC must be applied to L and N wires as shown in Fig. 11. Failure to do so will VOID the warranty and can result in irreversible damage to the appliance.

Power requirements

Check the markings on the rating plate of the water heater to be certain the available power supply corresponds to the water heater requirements.

This water heater must be directly connected to a 230V-240V AC, 50Hz mains power supply. When connected off grid, please make sure a 230V-240V AC 50Hz true sine wave power supply is available.

Do not connect this unit to inverters providing square sine waves.

Electrical connections



WARNING:

All electrical work and fixed wiring must be carried out by a qualified professional and in accordance with the Wiring Rules AS/NZS 3000 and local authority requirements.

The water heater must be installed on its own circuit with a breaker switch installed directly at the switchboard.

- ▶ Remove the top cover.
- ▶ Route the power supply cord through the orifice next to the drain port.
- ▶ Open the electric connection box.
- ▶ Connect the power supply wires and earth tab directly to the provided terminal block, ensuring there are no unnecessary excess wire loops inside the electric connection box.
- ▶ Close connection box and place in dedicated slot in the module base.

► Close the electric connection box.

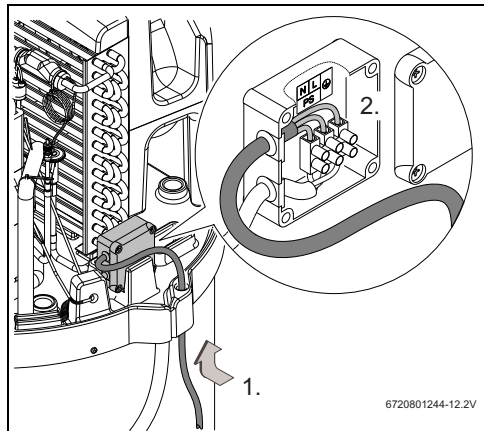

Fig. 11



Required 15A installation to be available in place.

The appliance must be power for the first time during the purge procedure after the tank was filled with water (→section 4.9)



WARNING:
Proper ground connection is essential.

The presence of water in the piping and water heater does not provide sufficient conduction for a ground. Non metallic piping, dielectric unions, flexible connectors, etc., can cause the water heater to be electrically isolated.

Electrical test requirements



WARNING:
This water heater contains electronic equipment and 500V insulation tests must only be conducted between active and earth and between neutral and earth. An active to neutral test WILL damage the electronics.

AS/NZS 3000:2000, clause "Results" (6.3.3.3.2) states:
"The value of 1 MOhm may be reduced to 0.01 MO for sheathed heating elements"

This water heater has been tested to AS/NZS 3350.1:2002 clause 16 "Leakage current and electric strength" and passed the requirements of this Standard. Therefore, this water heater

complies with the conditions stated in AS/NZS 3000:2000 clause 6.3.3.3.2 (b).

4.6 Installation with connectivity to photovoltaic systems



Only approved contractors may install the appliance, establish the electrical connections, and commission the equipment.



DANGER: Risk of electric shock!

► Isolate the appliance from the power supply using the switch board, disconnector or another electrical protection device before carrying out any work on electrical parts.



DANGER: Electric shock!

The capacitor must discharge after the appliance has been switched off.

► Wait at least 5 minutes.



DANGER: Risk of electric shock!

To ensure compliance with all safety requirements, defective power cables may only be replaced by an approved contractor.

- ▶ Open the PV connection accessory and connect the terminal strips tagged with PV+ and PV- to the inverter of your photovoltaic system.



An 1.5mm² core wire should be used to connect the PV connection accessory to the PV inverter.

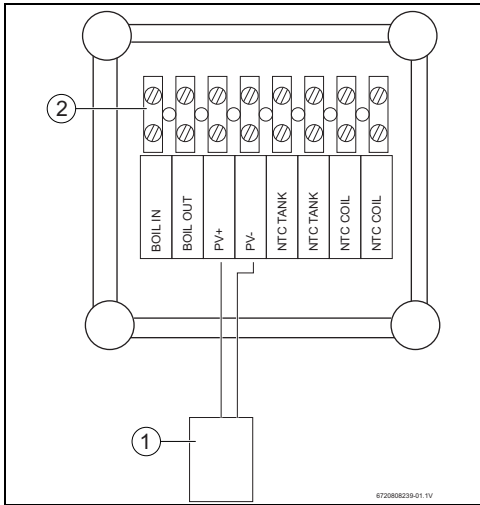

Fig. 12

- [1] ON/OFF volt-free contact for solar inverter or external demand
 - [2] Terminal strip
- ▶ Remove the top cover.
 - ▶ Route the signal cable through the orifice near the drain port, together with the power cable.

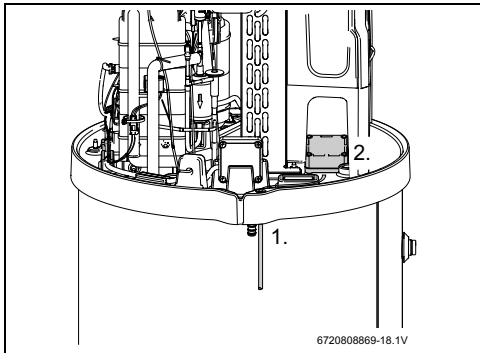

Fig. 13

- ▶ Place the PV connection accessory below the EPS volute.
- ▶ Route the communication cable below the EPS volute.
- ▶ Remove the protection cover of the HMI.
- ▶ Connect the communication cable to the dedicated port at the HMI.

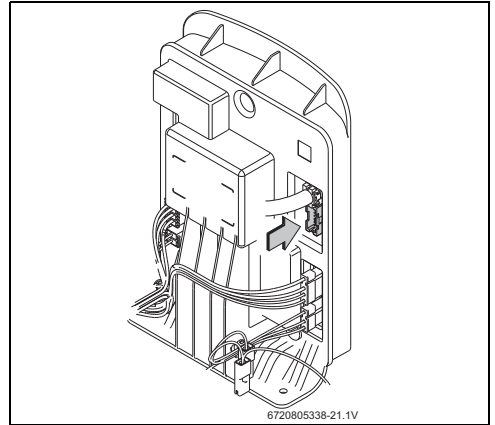

Fig. 14

- ▶ Put back the HMI protection cover on its position.
- ▶ Place back the top cover.

4.7 Installation configurations

4.7.1 Ecological ambient heat recovery

Even on cold days, heat is drawn from surrounding ambient air. The heat pump will operate at temperatures between a minimum of -7 °C and maximum of 40 °C. The electrical element will operate together with the heap pump cycle when the air falls below 0°C. The electrical element will operate only by its own when air temperature is below -7 °C or higher than 40 °C and heating is required. The efficiency of the water heater increases as the surrounding ambient air temperature increases.

Automatic safety controls are fitted to the water heater to provide safe and efficient operation.



CAUTION:

- ▶ Choose the right path to move the unit.
- ▶ Only move the unit in its original packaging.
- ▶ If the unit is installed in a metal building, proper insulation and compliance with the relevant technical standards of electrical equipment is to be provided.

4.8 Insulation blanket

If local codes require external application of thermal insulation blankets kits, the manufacturer's instructions included with the kit must be carefully followed.

Application of any external insulation, blankets, or water pipe insulation to this water heater will require careful attention to the following:

- Do not cover the temperature and pressure-relief valve.
- Do not cover access panels to the heating elements.
- Do not cover the operating or warning labels attached to the water heater or attempt to relocate them to the exterior of the insulation blanket.
- Do not block the air inlets/outlets and the top cover.
- Do not cover water heater control unit.

4.9 Fill the water storage tank

CAUTION: Damage to the appliance!

- ▶ Prior to commissioning the appliance, fill the storage tank with water and purge tank through hot water piping and fixtures.

Adjust the purge valve in order to facilitate the coupling to a draining hose and minimize any water splash to other components including the EPP base.

- ▶ Rotate the gray head (Fig. 16, [3]) of the purge valve clockwise (tightening) to adjust it.

- ▶ Open hot water outlet (Fig. 5, [6]) and one or more hot water taps.
- ▶ Open storage tank cold water inlet (Fig. 5, [8]). Storage tank filling starts.
- ▶ Close hot water taps only when water flow is free of air pockets.
- ▶ With the cold water inlet open and the hot water taps closed, open the purge valve (at least one complete rotation, Fig. 16 [1]) until water drops out through the purge valve outlet.
- ▶ Close the valve after a few moments, once the water flow is smooth without air bubbling.
- ▶ Connect the appliance to the power supply via fixed wiring installation, including earth conductor (→ section 4.5).

- ▶ Rotate circulation pump speed selector to position „III“ (Fig. 15)

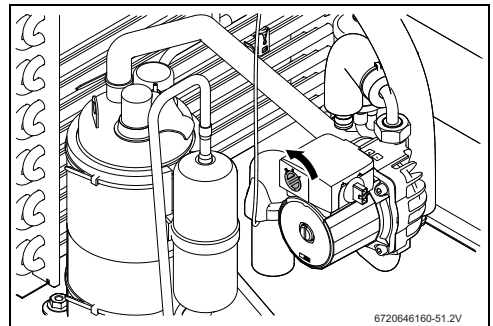

Fig. 15 Circulation pump

- ▶ Activate „Purg“ function (→ page 36, section 5.7.6).

Make sure that the appliance is in "manual" mode before activating the „Purg“. "man" must be written on the display. If "auto" is displayed:

- ▶ Select "man" mode (→ page 29, section 5.6).

CAUTION: Risk of scalding!

- ▶ Ensure that draining water from the purge valve presents no risk to people or property.

- ▶ Open purge valve (at least one complete rotation, Fig. 16, [1]) until water drops out through the purge valve outlet. Ensure that water drains correctly.

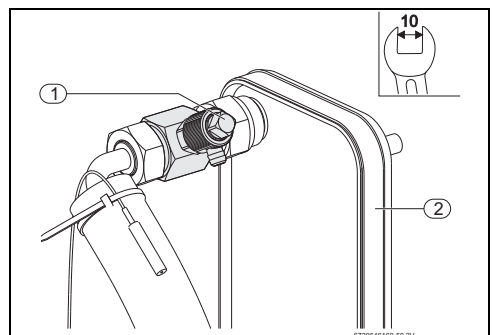

Fig. 16 Purge valve

- [1] Purge valve
- [2] Condenser (gas/water heat exchanger)

- ▶ Close purge valve.
- ▶ Open the purge screw of the circulation pump and leave it opened until the water leaks uniformly without visible air bubbles.

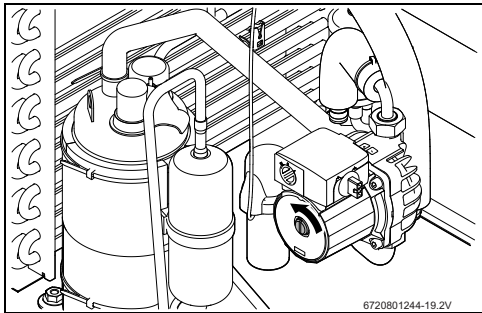

Fig. 17 Circulation pump purge screw

- ▶ Close the circulation pump purge screw.
- ▶ Wait for about 5 minutes until „Purg“ mode goes off. The number of minutes remaining are displayed.



During the 5min the „Purg“ function lasts, open the purge valve for a few seconds several times. This will release some air excess from the water loop.

- ▶ Rotate circulation pump speed selector to position „I“.
- Filling and purge procedures are now completed.

If, after a few minutes of operation (up to 20-30 minutes), display shows „E09“, you should:

- ▶ Reset the appliance (→ page 41, paragraph „Resetting the system“).
- ▶ Activate „Purg“ function (→ page 36, section 5.7.6) and repeat the subsequent purge steps described above.

4.9.1 Water characteristics

Usage of water with unsuitable characteristics can result in shortened product life.

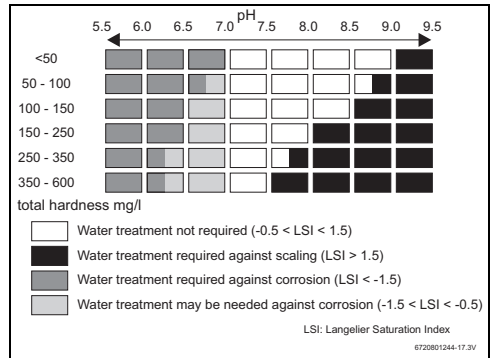

Fig. 18 Water treatment vs water characteristics

Please note that the Langelier saturation Index depends on the water temperature and the above information considers two extremes: 10 °C and 70 °C.

While corrosion is higher at low water temperature, scaling is more important at higher water temperature.

In case of water hardness above 600 mg/l, the Langelier saturation index must be determined to evaluate the necessity for water treatment.

Please require help from your technical assistance.

To ensure that the sacrificial anode works properly, the water conductivity must be within the limits of Tab. 4. In case not, treatment is required. Always ensure the water characteristics described in Fig. 18 when applying water treatment targeting the water conductivity

Water conductivity for sacrificial anodes

130 µS/cm - 1500 µS/cm

Table 4 Water conductivity



Enamelled tanks must not be used with completely desalted, distilled or de-ionised potable water.

4.10 Installation checklist

1. Tank location

- Is the room size less than 3 m x 3 m x 2,5 m (22,5 m³)? If yes, louvered door or similar ventilation is needed with minimum 500cm² venting area.
- Clearances according to figure 7 (section 3.7, page 16).
- Front of unit is free and clear.
- Is the water heater leveled? If not, adjust the adjustable feet, or add shims under the base of the unit.
- Are fixing straps (if required) in place?

2. Plumbing connections

- No leaks after filling the tank with water, either when water is flowing or is stationary.

3. Condensate lines are in place

- Condensate drain pipe connected to drain connection, and directed into a floor drain or a condensate pump

4. Temperature and pressure-relief valve is working and drain line completed per local code.**5. Electrical connections**

- Electrical connections are properly isolated

6. Water filling and purge procedure

- Water filling and purge procedure done according to section 4.9.

7. Sensors location

- Are the sensors at their correct place (Fig. 19, [A - fins temperature], [B - top tank temperature], [C - air temperature] and [D - bottom tank temperature])?

If not:

- ▶ Locate the sensors according to Fig. 19.

8. Verify control panel displays the water temperature inside the tank.**9. Top cover in place.****WARNING:**

The power supply to the appliance must not be activated until the system is filled with water.

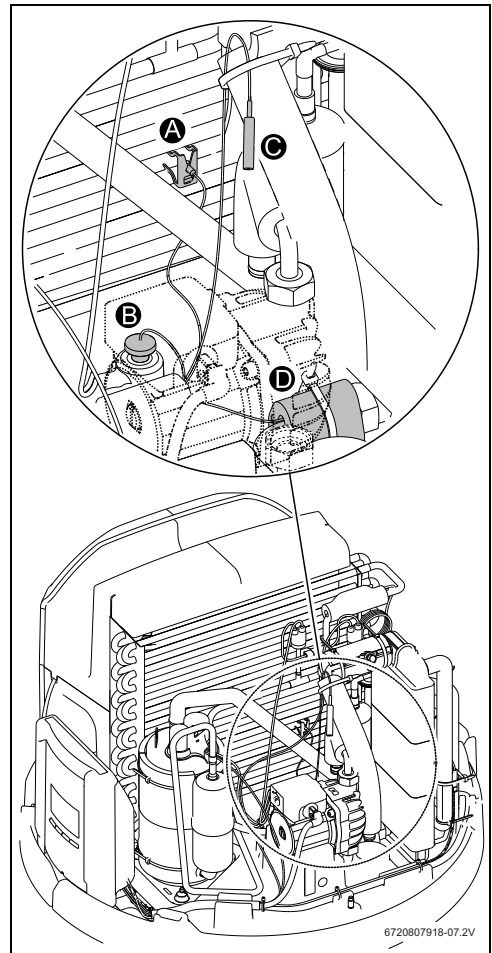

Fig. 19 Sensor positioning

4.11 What to expect from a “normal startup”

After the unit has been installed, with all electrical and water connections secured and checked, the unit should be filled with water and purged (→ section 4.9). The appliance will perform according to table 5 after purge function has been selected. In case the appliance is unplugged from mains and switched on again, the display will remain inactive for a few moments and the normal startup will be according to table 6.

Elapsed time	HPWH actions
0 to 5 minutes	Unit is silent. Water pump runs to complete the purge procedure.
5 to 7 minutes	Fan starts operating
7 minutes and beyond	Compressor in operation

Table 5 Normal startup when purge procedure is selected

Elapsed time	HPWH actions
0 to 2 minutes	Unit is silent. Water pump runs during the first minute.
2 to 4 minutes	Fan starts operating
4 minutes and beyond	Compressor in operation

Table 6 Normal startup when the appliance is switched on after have been unplugged from mains.



If the ambient temperature is outside of the range $-7\text{ °C} / +40\text{ °C}$, the appliance will not be able to run by using the heat pump cycle. The electric element will be used until the ambient air temperature returns to the operating range, therefore, the unit will not follow the startup described in tables 5 and 6.

4.12 Off-peak compatibility

The appliance is technically compatible to be connected to a fix line for off-peak tariff. However, the off-peak must be wisely used.

Off-peak periods of less than 16 hours might not ensure the re-heating, depending on the hot water demand and on the temperature of the air and inlet water. Ensure that your off-peak periods are suitable for your needs.

The weekly LEG mode requires additionally 6 to 8 hours. Therefore once a week this additional period must be ensured

to complete the thermal disinfection. It is recommended to program the LEG to be done when extended off-peak periods are available, typically weekends.

To optimize the comfort and maximize the savings, it is recommended the use of a power commutator between the normal line and the off peak line together with a programmed working period (→section 5.7.2). The best strategy will depend up on the hot water needs and ambient conditions.

In case time of use tariffs are available, it is recommended to use the programmed working periods (→section 5.7.2) to take full advantage of them.

In case of a temporary suspension on the water supply during a off-peak period the appliance may get unpurged and stop working during its restart. An error message will be displayed and the appliance will remain blocked. To minimize the possible inconveniences from a suppression on the water supply service, always check the appliance after such incident occurred.



NOTICE: Damage to the appliance!

Never use the off-peak in case the appliance is set to OFF mode and temperatures around 0 °C or below are expected: the anti-freeze mechanism will not be ensure!

4.13 Demand response

In a near future electrical energy management is foreseen to use communication with the electrical appliances to minimize grid load peaks and increase electrical energy distribution efficiency. This communication, named demand response, will be based in signals sent through the grid to which the electrical appliances are required to react accordingly. The end user is expected to benefit from lower tariffs when using appliances demand response capable.

The Compress 3000 is technically demand response ready. The Compress 3000 is technically prepared to what is expected to be known as Demand Response Modes 1 and 4 (DRM1 and DRM4). Under DRM1 the appliance is automatically switched ON or OFF according to the grid signal. Under DRM4 the appliance will automatically increase the set point to 66 °C (10% higher than the highest set point possible to be set) when the respective signal is sent through the grid. The interface between the grid and the appliance requires a Demand Response Enabling Device (DRED) and a BOSCH accessory. The availability of this feature and accessories requires regulation approval and release by the government authorities.

5 Appliance status information

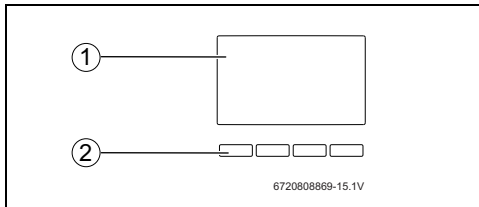

Fig. 20 Control panel

- [1] Display
- [2] Selection keys

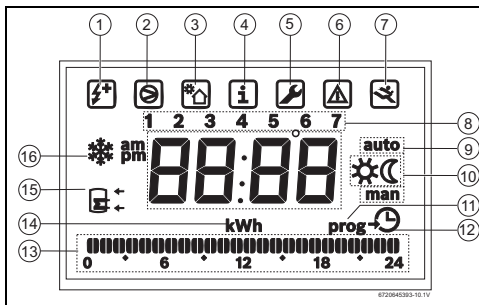

Fig. 21 Display

- [1] Electric heater ON/OFF indicator
- [2] Heat pump cycle ON/OFF indicator
- [3] Photovoltaic communication ON/OFF indicator
- [4] Information
- [5] Parameter adjustment entry
- [6] Error indicator
- [7] „Service“ menu entry
- [8] Days of the week
- [9] „auto/man“ functioning
- [10] Active/inactive periods indicator
- [11] „Prog“ menu entry
- [12] Clock adjustment
- [13] Timetable
- [14] Energy consumption unit
- [15] Storage tank sensor positions
- [16] „anti-freeze“ function

5.1 Safety warnings



WARNING:

If the hot water system is not used for two weeks or more, flammable hydrogen gas may accumulate in the water heater. To dissipate this gas safely, it is recommended that a non-electrically operated hot tap be fully opened for 2 minutes. During this procedure, smoking, open flames or operating electric appliances should be avoided.



DANGER:

Do not store or use gasoline or other flammable vapors and liquids, such as adhesives or paint thinner, in the vicinity of this or any other appliance. If such flammables must be used, open doors and windows for ventilation.



CAUTION: Turn off power to water heater if it has been subjected to overheating, fire, flood or physical damage.



CAUTION:

Do not turn on water heater unless it is filled with water.



CAUTION:

Do not turn on water heater if cold water supply shut-off valve is closed.



WARNING:

If there's any difficulty in understanding or following the Operating Instructions or the Care and Cleaning section, it is recommended to have a qualified person or serviceman performing the work.



Flammable vapours may be drawn by air currents from surrounding areas to the water heater.

5.2 Working display

Visible display symbol

Appliance allowed to operated (according to selected operation program).

A square around the electric element symbol and/or around the compressor symbol indicates if they are switched on.

Fig. 22 shows the display when only the compressor is operating.

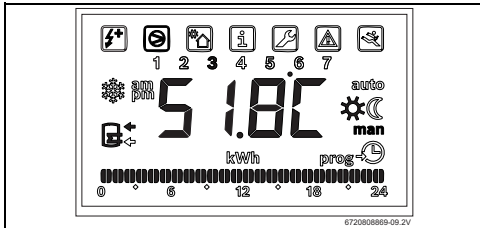

Fig. 22 Device operating

Visible display symbol

Appliance outside operating time period (according to selected operation program).

Fig. 23 shows the display when the appliance is inactive (inhibit to operate according to the selected program mode).

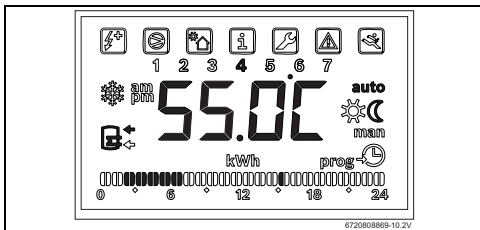

Fig. 23 Device inactive

5.3 Operation programs

Visible display symbol „auto“

Operating periods in accordance with defined programming (P1, P2 or P3).

Visible display symbol „man“

Permanent operation (24 h/7 days) without defined programming.

5.4 Setting the domestic hot water temperature



The water temperature is set to 56 °C at the factory.

- ▶ Press the "+" or "-" button to set the desired value between 30 °C and 60 °C.

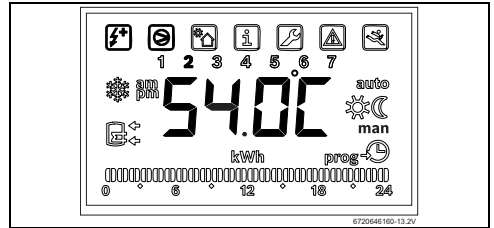

Fig. 24 Setting the temperature

- ▶ Press the "ok" button to confirm the setting.



The set value flashes until the setting is confirmed.

If the setting is not confirmed within 10 seconds, the previously set value is retained.



Once the temperature has been set, the display indicates the water temperature in the tank.



DANGER: Scalding!

A hot water scald potential exists if the water temperature is set above 50 °C. Children, disabled, and elderly people are at higher risk of being scalded.

- ▶ Always feel water temperature before bathing or showering.

Time/Temperature Relationship in Scalds

Tempera- ture	Time to produce a serious burn	
	Aged persons/ children under 5 years	Adults
50 °C	2-1/2 minutes	More than 5 minutes
52 °C	Less than 1 minute	1-1/2 to 2 minutes
55 °C	About 15 seconds	About 30 seconds
57 °C	About 5 seconds	About 10 seconds
60 °C	About 2-1/2 seconds	Less than 5 seconds
62 °C	About 1-1/2 second	Less than 3 seconds
65 °C	About 1 second	About 1-1/2 seconds
68 °C	Less than 1 second	About 1 second

Table 7

5.5 Main menu

Calling up the main menu

- ▶ Press and hold the "Menu" button for max. 3 seconds.

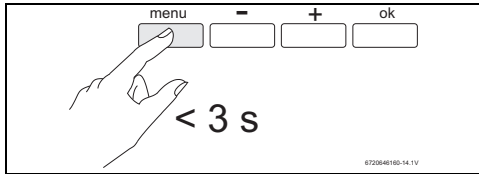

Fig. 25 Calling up the main menu

Once you have called up the main menu, you can select the following menus/submenus:

- **Prog - Operating programs**
 - Manual
 - P1
 - P2
 - P3
 - Hol
 - Off
 - **Set - Settings**
 - Date
 - Prog - programming of the operating times
 - Leg - thermal legionella disinfection
 - Plus - enhanced comfort function
 - Hea - heating by electric assistance
 - Purg - purge
 - Phot - photovoltaic
 - Fset - factory settings
 - **Info - Information**
 - **Sft - Software version**
- ▶ Use the "+" or "-" button to select the required menu.
▶ Confirm by pressing "ok".



To switch to the previous menu:

- ▶ Press the "Menu" button.
- or-
- ▶ Do not press any buttons for 15 seconds.

5.6 "Prog" submenu - Operating programs

You can set 6 different operating times in the "Prog" submenu.

- Manual
- P1
- P2
- P3
- Hol
- Off

5.6.1 "Manual" operating mode

Selecting this operating mode puts the appliance into continuous operation in order to keep the temperature at the set value for a longer period of time.

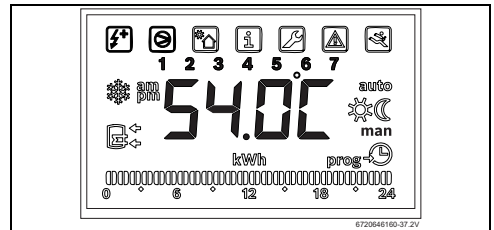

Fig. 26 "Manual" operating mode

5.6.2 "P1", "P2" and "P3" operating modes

"P1" operating mode

Selecting this menu causes the appliance to run according to the factory-set operating times (→ "P1" operating mode, page 29).

"P2" and "P3" operating modes

Selecting this menu causes the appliance to run according to the user-set operating times (→ "P2" and "P3" operating modes, page 32).

5.6.3 "Hol" mode

In this operating mode, the appliance is switched off 12 hours after the mode has been set and is switched back on two days before the end of the set holiday. If necessary, the electric booster heater is switched on during the set holiday period to provide "freeze protection".



Once the appliance is switched back on, the "Leg" function (→ section 5.7.3) is executed automatically.

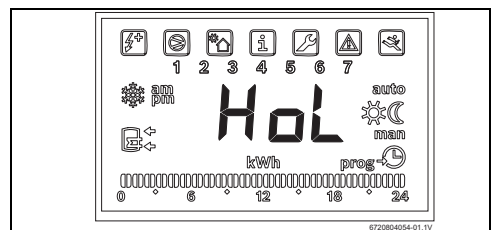

Fig. 27 "Hol" operating mode

Switching on the "Hol" function

- ▶ Call up the "Hol" function.

- ▶ Press "ok".
The current month flashes on the display.
- ▶ Use the "+" and "-" buttons to set the month in which the holiday ends.
- ▶ Press "ok".
The current day flashes on the display.
- ▶ Use the "+" and "-" buttons to set the day on which the holiday ends.
- ▶ Press "ok".
The "Hol" function is active.



In "Hol" mode, the appliance still operates for 12 hours.

The "Hol" operating mode can be set for a maximum of 4 months.

- ▶ Check that the date is correct (→section 5.7.1).
- ▶ The appliance must be connected to the mains power supply for correctly run the Holiday mode.

Deactivating the "Hol" function manually

To deactivate the "Hol" operating mode before the set date:

- ▶ Call up the "Prog" menu.
- ▶ Press "ok"
- ▶ Select "man" (manual mode).
The heat pump will start operating and will initiate a legionella disinfection.



In case of manual "Hol" deactivation do not use hot water before the legionella disinfection is completed, unless the last disinfection has occurred less than 7 days ago.

Tank freeze protection

The electric booster heater starts up when the water temperature in the tank falls below 5 °C and switches off again when the temperature reaches 8 °C.

5.6.4 "OFF" operating mode

In this operating mode, the appliance is switched off. If necessary, the electric booster heater is switched on by itself for the tank anti-freeze protection function.

The legionella disinfection cycle is ensured once per week according to the schedule, to ensure that the appliance is ready to be safely used immediately after being set back to any of the normal operation modes.



In "OFF" mode the anti-freeze and weekly LEG functions are assured.

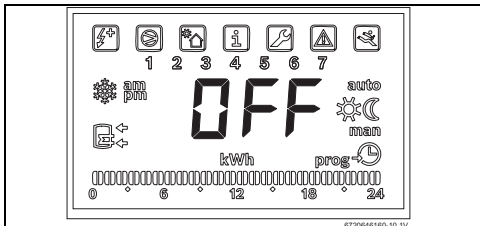

Fig. 28 "OFF" operating mode

5.7 "Set" submenu - Settings

You can set various parameters in the "Set" submenu:

- Date
- Prog - timetable operating programming
- Leg - legionella
- Plus - enhanced comfort function
- Hea - heating by electric assistance
- Purg - purge
- Phot - photovoltaic
- Fset - factory settings

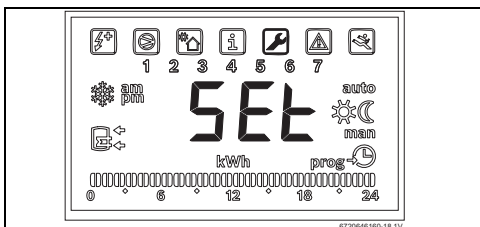

Fig. 29 "Set" function

5.7.1 Date - Setting the temperature unit, date, time and day of the week

Setting the temperature unit

On the 1st use, the user must select the temperature unit.

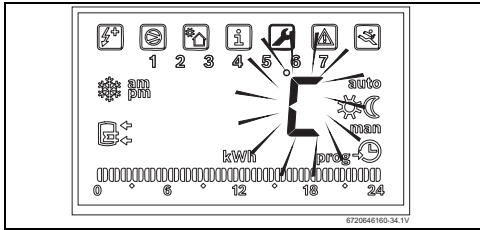

Fig. 30 Selecting the temperature units

- ▶ Press the „+“ or „-“ key to select the temperature unit.
- ▶ Confirm the selection by using the „ok“ key.
The year flashes on the display.

Setting the date

- ▶ Set the year by using the „+“ or „-“ key.
- ▶ Confirm by pressing „ok“.
The month flashes on the display.
- ▶ Set the month using the „+“ or „-“ key.
- ▶ Confirm by pressing „ok“.
The date is set and the day flashes on the display.

Setting day of the week and the time



Days 1,2,3,4, and 5 corresponds to Monday, Tuesday, Wednesday, Thursday and Friday, respectively. Days 6 and 7 corresponds to Saturday and Sunday, respectively.

- ▶ Set the day of the week using the „+“ or „-“ key.
- ▶ Confirm by pressing „ok“.
The hour flashes on the display.

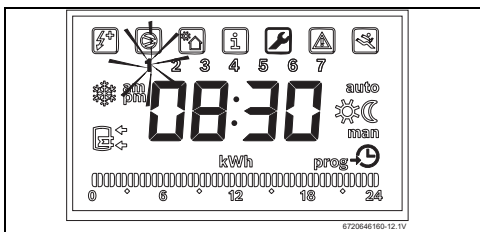

Fig. 31 Setting the day of the week



The „am/pm“ selection is only valid if „F“ is selected as temperature units.
If set to °C, time will be displayed in the 24 hour format.

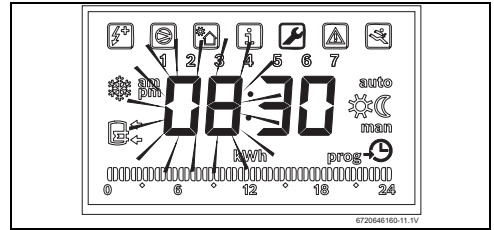

Fig. 32 Setting the time

- ▶ Set the hour by using the „+“ or „-“ key.
- ▶ Confirm by pressing „ok“.
Display shows the minute digits flashing.
- ▶ Set the minutes by using „+“ or „-“ key.
- ▶ Confirm by pressing „ok“.

5.7.2 Prog - Timetable operating programming

In the "Prog" submenu, you can set the operation period for the heat pump.

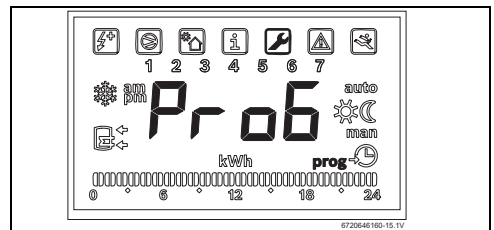

Fig. 33 "Prog" function

The following menus can be called up in the "Prog" submenu:

- "P1" operating time (days 1 to 5)
- "P1" operating time (days 6 and 7)
- "P2" operating time (days 1 to 5)
- "P2" operating time (days 6 and 7)
- "P3" operating time (days 1 to 5)
- "P3" operating time (days 6 and 7)
- "SIL" operating time (days 1 to 5)
- "SIL" operating time (days 6 and 7)

"P1" operating time

The heat pump only goes into operation during the operating times set at the factory. These cannot be changed:

Days 1 - 5: [00:00 → 06:00] and [16:00 → 19:00]

Days 6 - 7: [02:00 → 08:00]

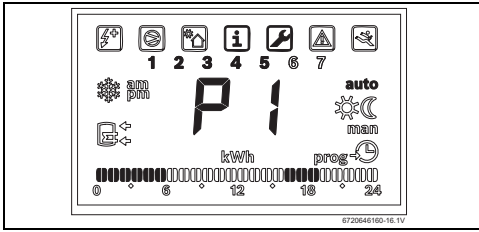

Fig. 34 "P1" operating time

"P2" and "P3" operating times

The heat pump runs according to the operating times set by the user.

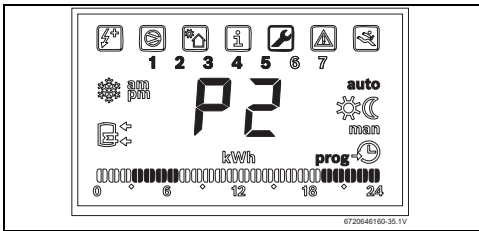

Fig. 35 "P2" and "P3" operating times

Setting the operating times for "P2" and "P3"

4 operating times are set for each function:

- 2 operating times for days 1 to 5
- 2 operating times for days 6 and 7

Setting the operating times

- ▶ Call up function "P2" or "P3" (→ section 5.6).
- ▶ Press "ok".
The start of the first operating time flashes.

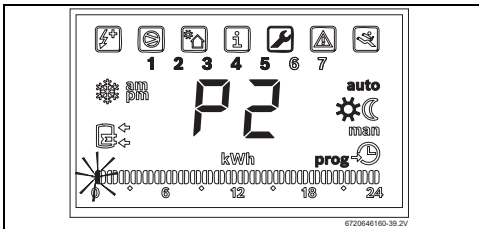

Fig. 36 Start of the first operating time

- ▶ Set the start of the operating time by using the "+" and "-" buttons.
- ▶ Press "ok".
The end of the first operating time flashes.
- ▶ Set the run time by using the "+" and "-" buttons.

- ▶ Press "ok".
The start of the second operating time flashes.

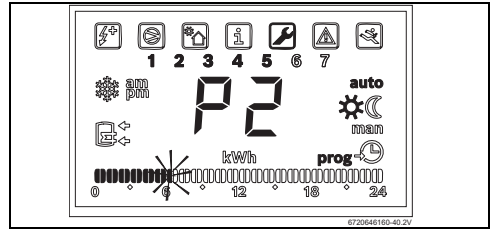

Fig. 37 Start of the second operating time



If the start of the second operating time is set so that it is within the first operating time, the first operating time ends automatically when the second operating time starts.

- ▶ Set the start of the second operating time by using the "+" and "-" buttons.
- ▶ Press "ok".
The end of the second operating time flashes.
- ▶ Set the run time by using the "+" and "-" buttons.
- ▶ Press "ok".
The operating time for days 1 to 5 is saved.

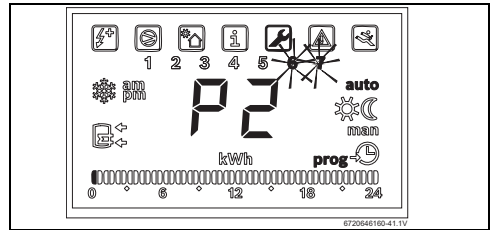

Fig. 38 Start of the first operating time for days 6 and 7

- ▶ Repeat the steps above for the operating times for days 6 and 7.
Once you have set the second operating time for days 6 and 7, the process of setting the operating times is complete.

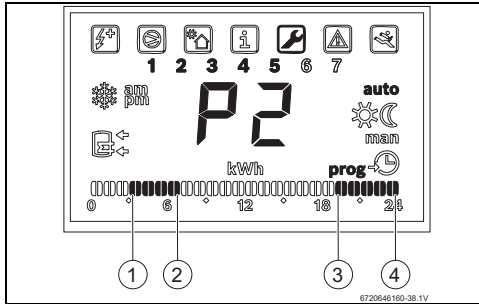

Fig. 39 Setting operating times

- [1] Start of the first operating time
- [2] End of the first operating time
- [3] Start of the second operating time
- [4] End of the second operating time

Deleting the operating time

- ▶ Set the start and end of the operating time to the same time.
The operating time is deleted.

If you do not wish to set a second operating time:

- ▶ Set the start and end of the second operating time to the same time.
The display will show "----".

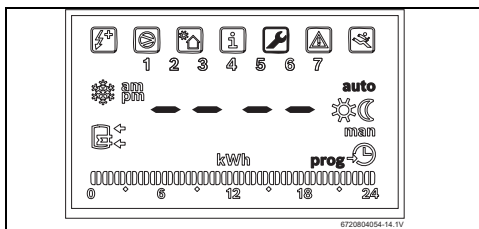

Fig. 40

"☀" symbol is displayed

During appliance operating time.

"☾" symbol is displayed

Outside of appliance operating time.

Noise reduction mode programming - „Sil“ function

i Setting a lower speed will decrease the appliance efficiency marginally. Activate the lower speed only in situations where lower noise levels are to be achieved.



In cases of moderate/strong wind it is highly recommended to **DO NOT** use the noise reduction mode, unless the air outlet of the appliance is not directly exposed to the wind. Direct and moderate/strong wind on the air outlet grille may result in an abnormal operation of the appliance and consequent larger heating times.

The „Sil“ function allows the selection of the ventilator speed in order to get lower noise levels.

The device is factory set with the highest fan speed activated.

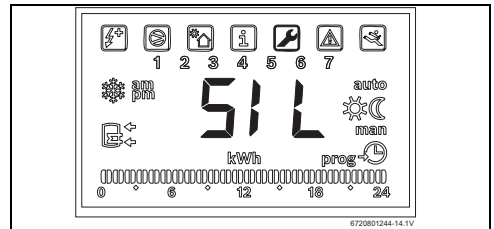

Fig. 41 „Sil“ function

Setting the noise reduction mode periods

2 noise reduction mode periods will be set in each of the programming steps:

- 2 periods for days „1 to 5“ and 2 periods for days 6 and 7
 - Start of 1st period
 - End of 1st period
 - Start of 2nd period
 - End of 2nd period

Programming of noise reduction mode periods

- ▶ Access the „Sil“ function.
- ▶ Press „ok“.
A bar flashes at the start schedule of the 1st noise reduction mode period and "☀" is shown.
- ▶ Use the „+“ and „-“ keys to set the noise reduction mode start schedule.
- ▶ Press „ok“.
The flashing bar shows now the stop schedule of the 1st period and "☾" is shown.
- ▶ Use the „+“ and „-“ keys to set the noise reduction mode duration.
- ▶ Press „ok“.
The flashing bar shows the start schedule for the 2nd noise reduction mode period and "☀" is shown.
- ▶ Use the „+“ and „-“ keys to set the noise reduction mode start schedule of the 2nd period.

- ▶ Press „ok“.
The flashing bar shows now the noise reduction mode stop schedule for the 2nd period and "☾" is shown.
- ▶ Use the „+“ and „-“ keys to set the noise reduction mode duration.
- ▶ Press „ok“.
The noise reduction mode periods for days „1 to 5“ are now set.
- ▶ Repeat the above described operations to set the noise reduction mode periods for days „6 and 7“.
Completed definition of the 2nd noise reduction mode period for days „6 and 7“ concludes the noise reduction mode programming.
After programming, the display, in the "Prog" sub-menu, shows SIL with the time bars indicating the periods when the noise reduction mode will be activated.

Select only one day period

- ▶ Select the first period according to the previously mentioned.
- ▶ Use "+" and "-" keys to set the the start and finish time to the same period.
The display shows "----".
- ▶ Press „ok“ to confirm.

Switching off the noise reduction mode period

- ▶ Access the „Sil“ function.
- ▶ Press „ok“.
Display shows the start schedule of the 1st noise reduction mode period flashing.
- ▶ Use the „+“ and „-“ keys to set the noise reduction mode start and finish time to the same period.
The display shows "----".
Repeat for 2nd noise reduction mode period, in case is set.
- ▶ Press „ok“ to confirm.
- ▶ Press „ok“ again and hold it for more than 3s until "Prog" and "☀" goes off.
The first element of the time bar blinks.
- ▶ Press "menu" to go out of the SIL mode submenu (no blinking).
The SIL menu will show no time bar.

5.7.3 „Leg“ function - automatic thermal disinfection

The „Leg“ function allows for the thermal disinfection process. The bacteria elimination process will be performed automatically once a week.

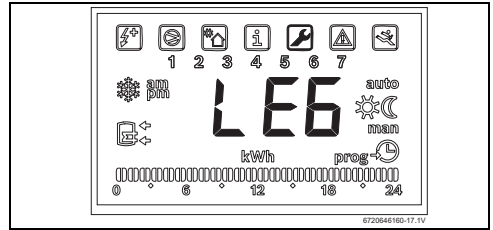

Fig. 42 „Leg“ function



Activation of the disinfection mode temporarily replaces any defined programming.



DANGER: Beware of burns!

Hot water can cause serious burns.

- ▶ During thermal disinfection the temperature may rise up to 72 °C at the top of the tank.
- ▶ Warn all users of the danger of burns and the need to perform thermal disinfection.



The disinfection process will run until stored water tank temperature at the bottom reaches more than 60 °C for at least 35 minutes.

Weekday programming of the "Leg" function

- ▶ Select "auto" by using "+" and "-" keys.
- ▶ Press „ok“.
„Leg“ function activated and day of the week for the disinfection flashing.

Define the day of the week for disinfection.

- ▶ Select the day, by using the „+“ and „-“ keys.
- ▶ Press „ok“.

Define the time to start disinfection

- ▶ Select the time, by using the „+“ and „-“ keys.
- ▶ Press „ok“.

Upon reaching a temperature of 60 °C at the bottom part of the tank for more than 35 minutes, the appliance returns to normal operation according with the previous settings.



In case a programmed period (P1, P2 or P3) is selected, the auto-activation of the LEG mode will be postponed to the next activation of the selected programmed period. The finalization of the thermal disinfection will have priority over the end of the programmed period, i.e., in case the programmed period is too short to allow the conclusion of the LEG mode, the appliance will be forced to operate until the thermal disinfection is concluded.

Manual activation of the „Leg“ function

- ▶ Access the „Leg“ function and press „ok“.
- ▶ Select "**man**" by using "+" and "-" keys.
- ▶ Press „ok“.
„Leg“ function activated.

Upon reaching a temperature of 60 °C at the bottom part of the tank for more than 35 minutes, the device returns to the previously selected mode.



The disinfection cycle manually activated will not inhibit the automatically scheduled disinfection cycle.



The legionella disinfection may take additional 6 to 8 hours to be conclude after the regular heating assured by the heat pump cycle. To draw off hot water from the tank during the last stage of the legionella disinfection may extend the process. In case 24 hours have passed since the legionella process has been activated, the appliance will turn on the auto-boost to speed it up. Therefore, to maximize the appliance efficiency, it is recommended to always program the legionella to a period where no hot water consumption is expected for a longer period of time combined with low energy tariffs: for instance, program the start of the legionella cycle to the end of the afternoon allowing the appliance to recover during the evening and conclude the disinfection during dawn.



In situations where high consumption of hot water are combined with shorter periods of no consumption, the water speed selector should be adjust to position "III" (see section 4.9) in order to minimize the probability of not having the disinfection process concluded in due time (less than 48h after starting).



During the final period of the legionella control cycle, when the electrical element ensures the disinfection, the appliance will remain silent while flashing LEG on the display screen. Furthermore, to increase the energy savings and ensure that the water is not overheated, the electrical element works intermittently. Hence, there are periods when the electrical heater remains off but the unit is still performing the legionella disinfection.



After the LEG cycle has concluded, it is possible that the appliance will starts operating even though the temperature displayed is above the selected set point. This is an advanced comfort feature incorporated in to the appliance to heat up only the lower part of the tank (if required). Therefore, this feature ensures a quick temperature recovery for the lower half of the storage tank when hot water is tapped after a legionella disinfection cycle and the top of the tank remains around the set point.

5.7.4 „PLUS“ - enhanced comfort function

The "PLUS" is a comfort function which is factory set to be active but can be deactivated.

This function enables the appliance to automatically switch on the electrical heater together with the heat pump cycle when the air temperature is below 10 °C, the water temperature at the bottom is cold, and a rapid temperature decrease at the top of the tank is detected. Hence, by activating the auto boost, the appliance will initiate a fast recover at the top of the tank to face a potential lack of hot water. Once a hot water buffer is created at the top, the appliance will proceed the recover by using the heat pump cycle only.

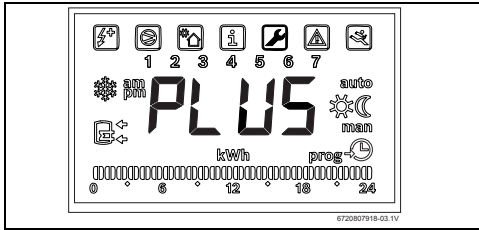

Fig. 43 „PLUS“ function

To deactivate/activate the „PLUS“ function

- ▶ Access „PLUS“ function and press „ok“.
- ▶ Use "+" and "-" keys to select "on" or "off" and press "ok" to confirm selection.
- ▶ Press "menu" to exit.
"PLUS" is displayed.

5.7.5 „HEA“ - heating by electrical assistance

The „HEA“ function is only available in case of malfunctioning of the heat pump cycle and requires technical assistance guidance.

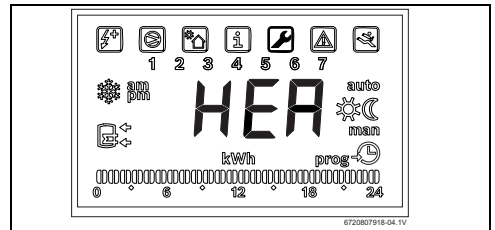

Fig. 44 „HEA“ function

5.7.6 „Purg“ function - purge

„Purg“ function is an auxiliary feature for the system purging process.

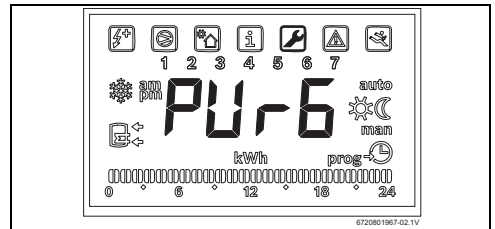

Fig. 45 „Purg“ function

To activate „Purg“ function

- ▶ Access „Purg“ function and press „ok“. The circulation pump will start functioning and the timetable is displayed below "Purg". After 5 minutes the appliance returns to the normal operation according to the settings previously selected.



During the period the "Purg" function is active, the display shows the remaining time (minutes) until the procedure is completed.

5.7.7 “PHot” - photovoltaic

The "PHot" function allows the appliance to communicate with a photovoltaic system to maximise energy savings. By enabling the function, the appliance will operate mostly when the photovoltaic energy is available, depending on the comfort and override settings (see paragraphs ""PHCF" - Photovoltaic comfort function" and ""PHor" - Priority of the photovoltaic system").

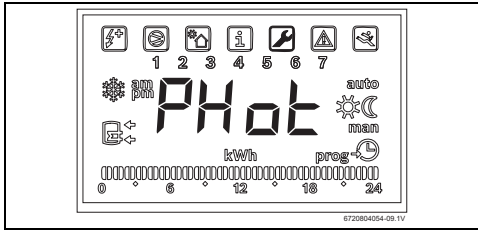

Fig. 46



This function should only be used if the PV communication accessory has been correctly installed and connected to the photovoltaic inverter (→section 4.6). By enabling this function without being connected to a photo-voltaic system will cause the heat pump to under perform or even malfunction.



Legionella cycle will always have priority over the photovoltaic function: regardless of the availability of photovoltaic energy, the legionella cycle will always be performed.

Switching the communication with the photovoltaic system on/off

- ▶ Access „PHot“ function and press „ok“.
"Set" is displayed.
- ▶ Press „ok“.
- ▶ Use "+" and "-" to switch to "on" or "off".
- ▶ Press „ok“.
"Set" is displayed.



If the photovoltaic system is switched to ("on"), the display shows the Photovoltaic communication ON/OFF indicator.

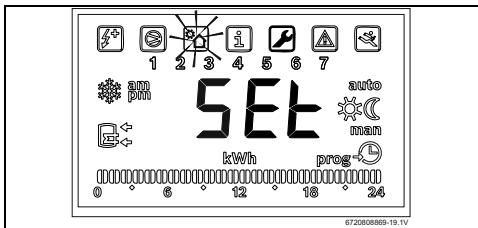

Fig. 47

"PHor" - Priority of the photovoltaic system

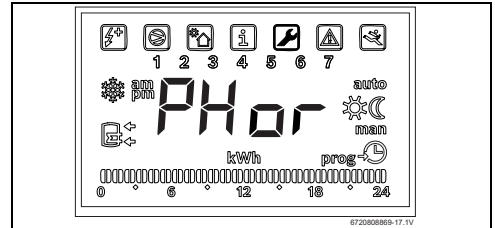

Fig. 48

This parameter defines whether the photovoltaic system should take priority during the operation times "P1", "P2" or "P3" which might have being set.

- ▶ Access "PHot" sub-menu.
- ▶ Use "+" and "-" keys to find the "PHor" sub-menu.
- ▶ Press "ok".
- ▶ Use "+" and "-" to set the photovoltaic priority to "ON" or "OFF":
 - "ON": When photovoltaic energy is available the appliance will always switch on, overriding any enabled "P1", "P2" or "P3" settings.
The Photovoltaic function will have priority over "P1", "P2" and "P3" programs
 - "OFF": The appliance will only operate at the programmed times defined in "P1", "P2" or "P3", regardless the availability of the photovoltaic energy. Programs "P1", "P2" and "P3" have priority over the photovoltaic function.



When the appliance is operating with photovoltaic energy, "SySt" flashes on the display.

- ▶ Press "ok" to confirm selection.
"PHor" is displayed

"PHCF" - Photovoltaic comfort function

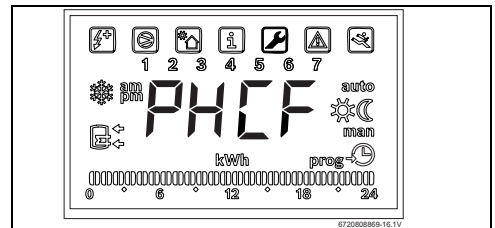

Fig. 49

This function ensures a minimum water temperature of 40 °C inside the tank. When the Photovoltaic comfort function is

enabled the appliance checks the bottom temperature every time the top temperature drops 1 °C. If the bottom temperature is below 40 °C the appliance re-heats the water until the bottom temperature reaches 40 °C or the set point is achieved.

Instead of enabling this comfort function it is possible to define a start condition (to be used when there is no photovoltaic energy) to a value between 15 °C and TSet- 5 °C. The appliance will start to operate when the top temperature drops below the set value, regardless of the availability of energy generated by the photovoltaic system.

When "on" is selected the minimum water temperature of 40 °C is ensured for all water in the tank, regardless of the availability of energy generated by the photovoltaic system. However, by selecting a temperature between 15 °C and TSet-5 °C, the appliance does not check the bottom temperature. Instead it starts the operation when the top sensor registers a temperature below the set value, regardless the bottom temperature. This approach can compromise the comfort of the user but will maximise the savings from the photovoltaic system.

- ▶ Access "PHot" sub-menu.
- ▶ Use "+" and "-" keys to find the "PHCF" sub-menu.
- ▶ Press "ok".
- ▶ Use "+" and "-" to switch the comfort function "on" or to select a temperature between 15 °C and TSet-5 °C.



Selection is not circular and after TSet-5 °C there is an "on" option.

- ▶ Press "ok" to confirm selection.
"PHCF" is displayed

Defining the inverter contact type

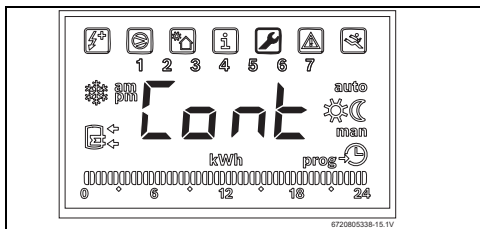

Fig. 50

- ▶ Use "+" and "-" to find the "Cont" sub-menu"
- ▶ Press „ok“.
- ▶ Use "+" and "-" to set the inverter type as "no" or "nC".
 - "no": Normally open
 - "nC": Normally closed

- ▶ Press „ok“ to confirm selection.
The inverter is defined and "Cont" is displayed.
"PHot" settings are now concluded.

5.7.8 „Fset“ function - factory resetting

„Fset“ function can be used to restore the original factory settings.

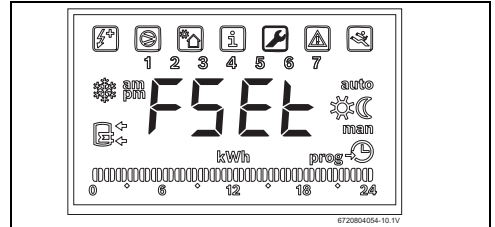

Fig. 51 „Fset“ function

To restore the original factory settings

- ▶ Access „Fset“ function and press „ok“.
"rset" is displayed.
- ▶ Press „ok“.
After 10 seconds the default settings are restored (→ section 5.12).

5.8 „Info“ - information

The „Info“ sub-menu displays the cumulative consumption.

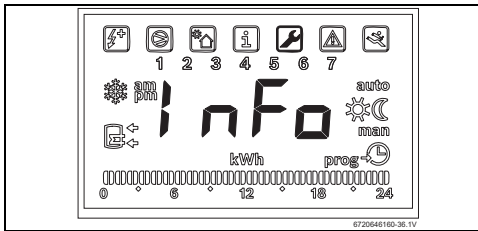

Fig. 52 „Info“ function

Displaying the consumption

- ▶ Access the „Info“ function and press „ok“.
The cumulative consumption in kWh is displayed.
Counter automatically resets to “000” once the value reaches 1193 kWh.

„reset“ consumption

Display showing the cumulative consumption.

- ▶ Press „-“.
„del“ indication is displayed.

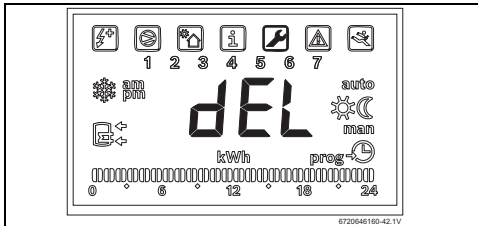

Fig. 53 „del“ function

- ▶ Press „ok“.
The meter restarts the count.

5.9 „Sft“ - software version

The „Sft“ sub-menu allows the visualization of the current software version.

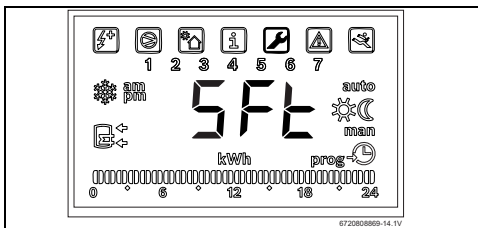

Fig. 54 „Sft“ function

Displaying the software version

- ▶ Access the „Sft“ sub-menu and press „ok“.
- ▶ Press “+” and “-” keys to navigate between 4 characters and 4 digits.
The software version is identified by 4 characters followed by 4 digits (Ex: HPAF 0836).

5.10 One shot boost and auto boost at negative temperatures

In order to guarantee faster recovering times when the air temperature is low and the thermal power of the heat pump cycle decreases, the appliance is equipped with two boost functions:

- auto-boost
- one shot boost



The appliance efficiency decreases when boost is active, as part of the heating is ensured by the backup electric heater. For this reason, the auto boost is limited to very low air temperatures and the one shot boost is recommended to be used only when large loads of hot water were drawn and a faster recovering time is required to fulfill the next hot water needs.

Note that, between 0 °C and 15 °C air temperature when the boost is active the heat pump cycle ensures only 1/3 to 1/2 of the heating.

For higher air ambient temperatures the fraction of the heating ensured by the heat pump cycle increases due to the higher thermal power.

Auto-boost function

The auto-boost function switches on the electric heater together with the heat pump cycle when the air temperatures drops below 0 °C.

As soon as the air temperature rises above 0 °C the electric element is switched off and the heating is ensured by the heat pump cycle alone.

Below 0 °C air temperature, when the auto-boost is on, typically only one third of the heating is provided by the heat pump cycle.

The auto-boost is switched on as well, when the LEG disinfection is not finalized in 24h.

One shot boost function

The one shot boost needs to be manually activated and is automatically deactivated once the water reaches the set point.

Activation and deactivation of the one shot boost function

- ▶ Press and hold the "+" and "-" buttons together for more than 3 seconds to activate or deactivate the one shot boost.

When the auto-boost function or the one shot boost function is active, "FULL" is displayed on the HMI, alternating with the to tank temperature.

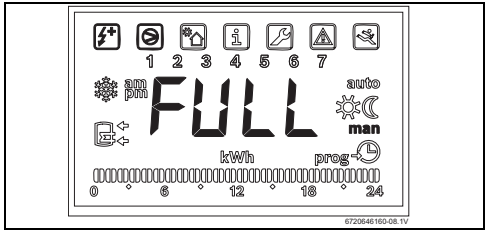

Fig. 55 Auto-boost or one shot boost active



When the boost was activated automatically (air temperature below 0 °C, activated by PLUS function, LEG cycle running for more than 24h) it can not be manually deactivated.

5.11 Troubleshooting

This device is equipped with a troubleshooting function. Error indication is performed by means of a code (Table 8, page 48) corresponding to the error indication symbol in the digital display (Fig. 21, [6]). In most cases, the device will only return to normal functioning following elimination of the cause of the malfunction and resetting of the device.

To identify the malfunction, see chapter 7.

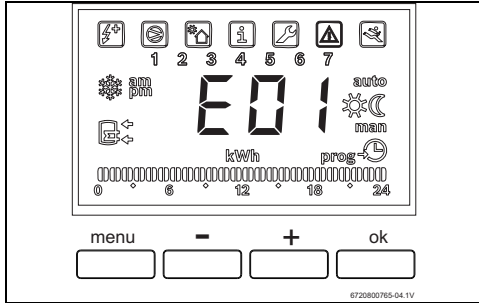

Fig. 56 Error code

Resetting the system

- ▶ Press the „ok“ key and hold it down for more than 3 seconds.

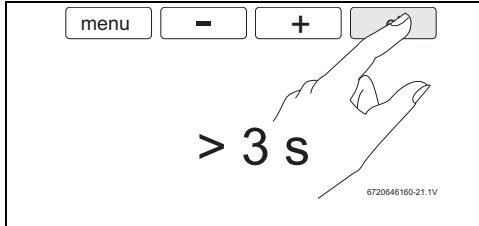

Fig. 57 Resetting the system

5.12 Factory configurations

Upon setting the temperature units and timetable, the device will operate according to the factory set values:

- Manual functioning: „manual“ (→ section 5.3)
- Set point: 56 °C
- Legionella: Week day 6 and Time 00:00
- PLUS: ON
- Noise reduction mode: Disable

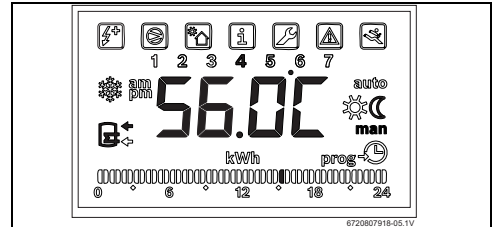

Fig. 58 Initial menu

5.13 Controls

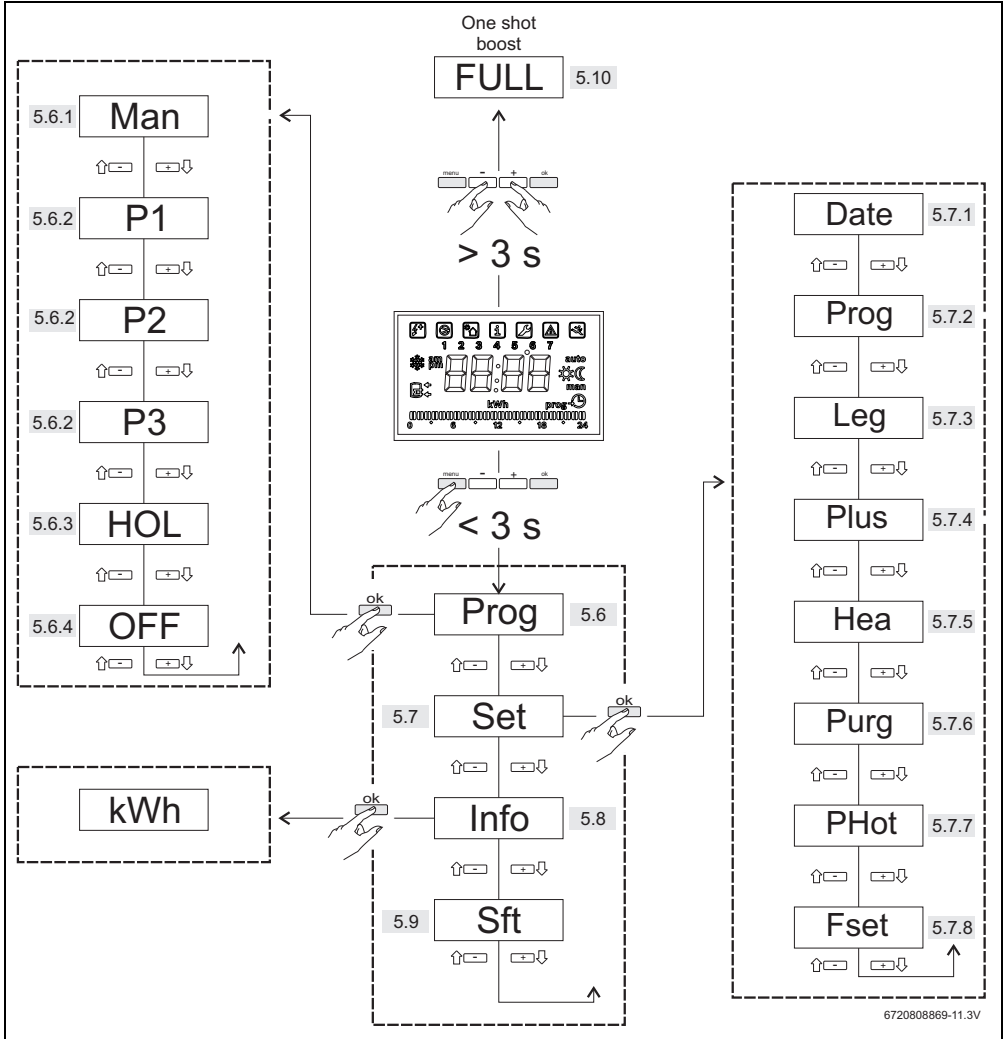

Fig. 59



6 Maintenance and repair



WARNING:

The water heater should be serviced by a qualified professional and in accordance with the Plumbing Standard AS/NZS 3500.4 and local authority requirements.



WARNING:

Before manually operating the relief valve, make certain no one will be exposed to the danger of coming in contact with the hot water released by the valve. The water may be hot enough to create a scald hazard. The water should be released into a suitable drain to prevent injury or property damage.



It is part of normal operation for the Temperature and Pressure Relief valve to discharge periodically. This is due to thermal expansion in a closed water system. If this discharge becomes excessive and runs continuously, contact plumbing contractor. Do not plug the relief valve outlet.

Properly maintained, your water heater will provide years of dependable trouble-free and economic service.

It is suggested that a routine preventive maintenance program is established and strictly followed by the user.

6.1 Periodic Inspection

It is recommended that a periodic inspection of the operating controls, heating elements and wiring should be made by service personnel qualified in electric appliance repair.

Most electrical appliances, even when new, make some sound when in operation. If the hissing or singing sound level increases excessively, the electric heating element may require cleaning. Contact a qualified installer or service agent.

Additionally it is also recommended that the evaporator and refrigeration circuit are checked every two years for dust and residues. In dusty environments it may be necessary to have the appliance checked and cleaned on a more regular basis.

6.2 Temperature and pressure relief valve (PTR Valve)

At least every 6 months:

- ▶ Lift and release the lever handle on the temperature and pressure-relief valve, to make certain the valve operates freely.

Allow several liters to flush through the discharge line to an open drain.

Never replace the PTR Valve with one which has a higher pressure rating than is specified for your water heater.

If the valve does not discharge water when the release lever is opened or does not seal properly when release lever is closed, replacement by an authorised person must be arranged without delay.

The PTR Valve is not serviceable.



DANGER:

Before manually operating the relief valve, make certain no one will be exposed to the hot water released by the valve. The water drained from the tank may be hot enough to present a scald hazard and should be directed to a suitable drain to prevent injury or damage.

6.3 Flushing tank

A water heater's tank can act as a settling basin for solids suspended in the water. It is therefore not uncommon for hard water deposits to accumulate in the bottom of the tank.

It is advisable to periodically flush the tank of these deposits by draining and then refilling the unit (see section 6.4).

6.4 Draining the Water Heater



CAUTION:

Shut off power to the water heater before draining water.



CAUTION: Risk of scalding!

Check the appliance's DHW temperature before opening the safety valve.

- ▶ Wait until the water temperature has dropped enough to prevent burns and other damage.



Large volumes of water will drain from the cold water inlet (>270 liters).

- ▶ Ensure proper drainage of water.

- ▶ Close cold water supply.
- ▶ Open a hot water tap (preferably one installed at the same level as the appliance) to relieve pressure and wait until flow substantially decreases.
The pressure can also be released by manually opening the PTR valve after ensuring all safety conditions are met to avoid any scald hazard (→section 6.2)
- ▶ After ensuring a proper drainage solution, remove cold water inlet connection and wait until water is drained.

6.5 Vacation and Extended Shutdown

If the water heater is to remain idle for an extended period of time, the power and water to the appliance should be turned off to conserve energy and prevent the build up of dangerous hydrogen gas.

The water heater and piping should be drained if they might be subjected to freezing temperatures. After a long shutdown period, the water heater's operation and controls should be checked by qualified service personnel. Make certain the water heater is completely filled again before placing it in operation.



Note: refer to the Hydrogen Gas Caution in the Operating Instructions (→section 5.1).

6.6 Clearing the Condensation Drain Tubes

The condensate drain is located at the back of the water heater. If blocked, water will spill down the outside of the unit.

- ▶ Remove the condensate drain pipe.
- ▶ Clear any debris and reattach.
- ▶ Periodically inspect the drain line and clear any debris that may have collected in the line.
- ▶ See Installation Instructions for more information.

6.7 Refrigerant circuit



NOTICE: Refrigerant leak!

- ▶ Repairs to the refrigerant circuit (e.g. to the compressor, condenser, evaporator, expansion vessel) may only be carried out by an authorised contractor.

6.8 Anode Rod servicing

A water heater anode rod is the most important safeguard any storage tank has against corrosion and premature failure. Inspecting the anode rod is therefore very important. Sacrificial anodes are designed to deteriorate overtime. Most water heating industry professionals recommend inspecting the anode yearly.

Homes with salty or softened water supplies should consider more frequent inspection. When in doubt consult a local water heating professional.

- ▶ Arrange for an authorised person to inspect the anode and replace it if required.

6.9 Checking/replacing the magnesium anode



The appliance is protected against corrosion by an internal magnesium anode.



WARNING: Damage to the appliance!

The magnesium anode must be installed before commissioning the appliance.



WARNING: Damage to the appliance!

Appliances operated without this protection are excluded from our warranty.

- ▶ Check the magnesium anode yearly and replace it if required.

The internal wall of the DHW storage tank is coated with a double glass lining. The coating is designed for normal quality water (section 4.9.1, page 24). When using more corrosive water, the warranty only applies if additional safety measures (i.e. dielectric joints) have been taken, and the magnesium anode is checked more frequently.

To check the protective anode:

- ▶ Isolate the appliance from the power supply.
- ▶ Isolate appliance from water supply.
- ▶ Open a hot water tap (preferable one install at the same level as the appliance) to relieve pressure and wait until flow substantially decreases.

The pressure can be released as well by manually open the PTR valve after ensuring all safety conditions to avoid any scald hazard (→section 6.2)

- ▶ Remove the anode rod protective cap.

- ▶ Remove the anode rod.

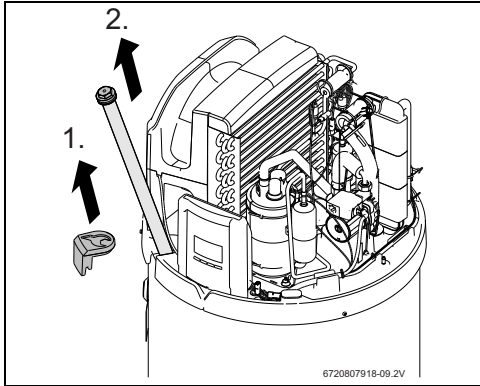

Fig. 60 Check state of magnesium anode

- ▶ Visually inspect and replace it if necessary.
- ▶ Refill tank and purge the system (→section 4.9).

6.10 Service menu



This menu is meant to assist the contractor and may be used by the contractor only.

Calling up the service menu

- ▶ Press and hold "menu" and "ok" simultaneously for 3 seconds.

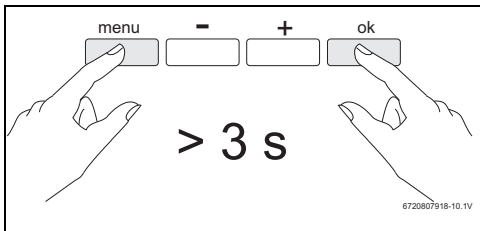

Fig. 61 „Service“ menu

When the service icon "  " appears, the service functions can be accessed.

- ▶ Use "+" or "-" key to select the required menu.
- ▶ Confirm by pressing "ok".

"0d" function

The "0d" function can be used to check the water temperature set value.

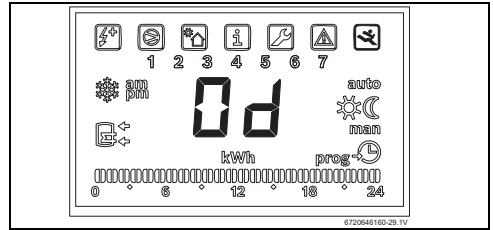

Fig. 62 DHW outlet temperature

"1d" function

The "1d" function can be used to check the temperature at the top part of the storage tank.

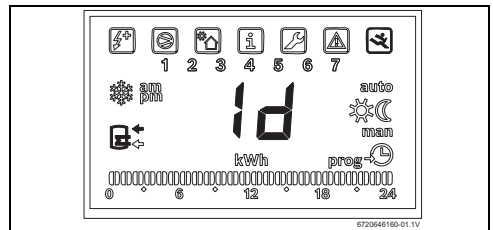

Fig. 63 Temperature at the top part of the storage tank

"2d" function

The "2d" function can be used to check the temperature of the water entering the module and coming from the bottom of the tank.



The value displayed only corresponds to the bottom temperature if the water pump is working; when the compressor is ON; during all the LEG cycle; or when the "Purg" function is active. Otherwise the value shown corresponds to the temperature of the stagnated water inside the piping at the module.

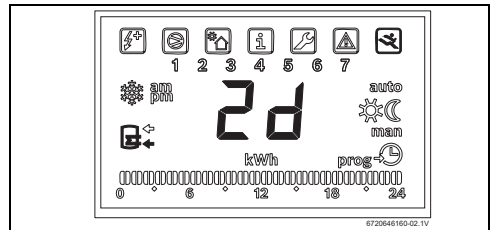

Fig. 64 Temperature at the bottom part of the storage tank

"3d" function

The "3d" function can be used to check the ambient air temperature.

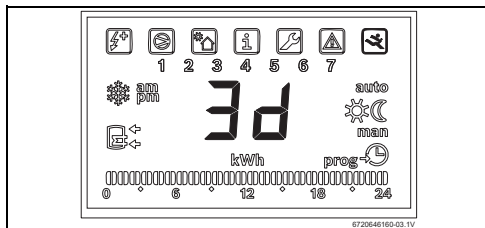

Fig. 65 Ambient air temperature

"4d" function

The "4d" function can be used to check the evaporator fins temperature.

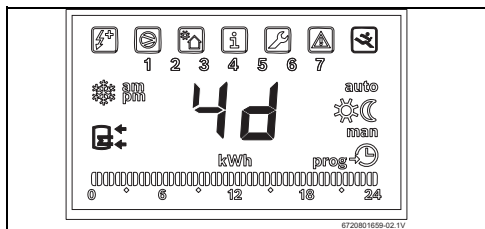

Fig. 66 Evaporator fins temperature

"5d" function

The "5d" function can be used to check the current consumption of the appliance.

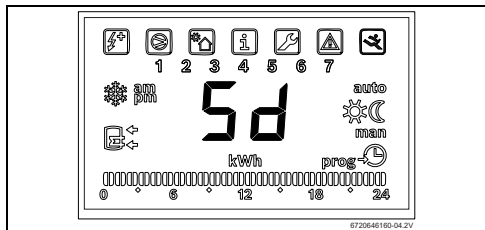

Fig. 67 Current consumption of the appliance

"6d" function

Suppressed.

"7d" function

The "7d" function is not used.

"8d" function

The "8d" function can be used to check the number of gas defrosts performed.

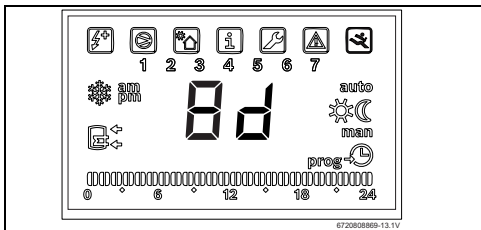

Fig. 68 Number of gas defrost cycles

Functions "1F" to "10F"

The functions "1F" to "10F" can be used to display the last 10 faults that occurred.

- "1F" - last fault
- "2F" - second to last fault
-
- "10F" - tenth to last fault

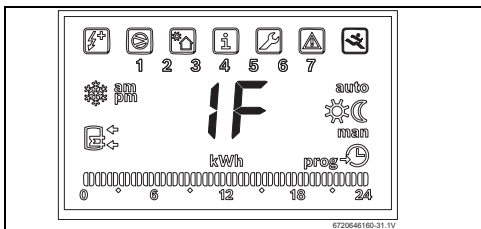

Fig. 69 Last fault

"EE" function

The "EE" function can be used to delete the fault history.

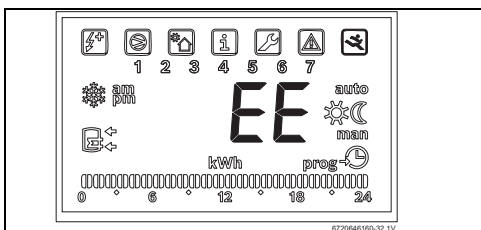

Fig. 70 Deleting the service history



7 Display

7.1 Fault display

Installation, maintenance and repairs may only be carried out by an authorised contractor. The following table lists the fault codes.

Display	Description	Solution
E01	Fault in the top storage tank temperature sensor	▶ Notify authorised contractor
E02	Fault in the bottom storage tank temperature sensor	▶ Notify authorised contractor
E03	Fault in the temperature sensor at the air inlet	▶ Notify authorised contractor
E05	Fault in the temperature sensor at the evaporator fins	▶ Notify authorised contractor
E09	Incorrect system purging Water pump blocked (water not recirculating) Hydraulic circuit blocked (water not recirculating) System unpurged due to water shortage	▶ Notify authorised contractor ▶ Reset the system
E10	Heating element faulty Fault in the high limit safety cut-out	▶ Notify authorised contractor
E11	Fault in the fan Leak in refrigerant circuit Fault in the compressor Fault in the expansion valve Fault in the dry filter	▶ Reset the system and notify authorised contractor
E13	Fault in the positioning of top storage tank temperature sensor	▶ Notify authorised contractor
E14	Fault in the fan Air flow blockage	▶ Notify authorised contractor

Table 8 Fault codes

7.2 Displays

Display	Description	Note
E04	Temperature in storage tank $\geq 80^{\circ}\text{C}$	▶ Isolate electrical connection ▶ Notify authorised contractor
E06	Hold down setting keys longer than 30 seconds	▶ Release keys

Table 9 Display indications

Display	Description	Note
LEG	Thermal disinfection process running	When temperature reaches and holds 60 °C for 35 mins, the appliance goes back to the mode previously selected.
HOT	Temperature of inlet air ≥ 40 °C	Occurs when air inlet is higher than 40 °C or lower than -7 °C, respectively. The appliance will automatically switches off the heat pump cycle and operates with the electrical heater if heating is required.
COLD	Temperature of the inlet air ≤ -7 °C	
LFLO	Appliance may be with low air flow which will transform into an E14 if conditions persist for 24 hours	► Notify authorised contractor

Table 9 Display indications

8 Electrical diagram

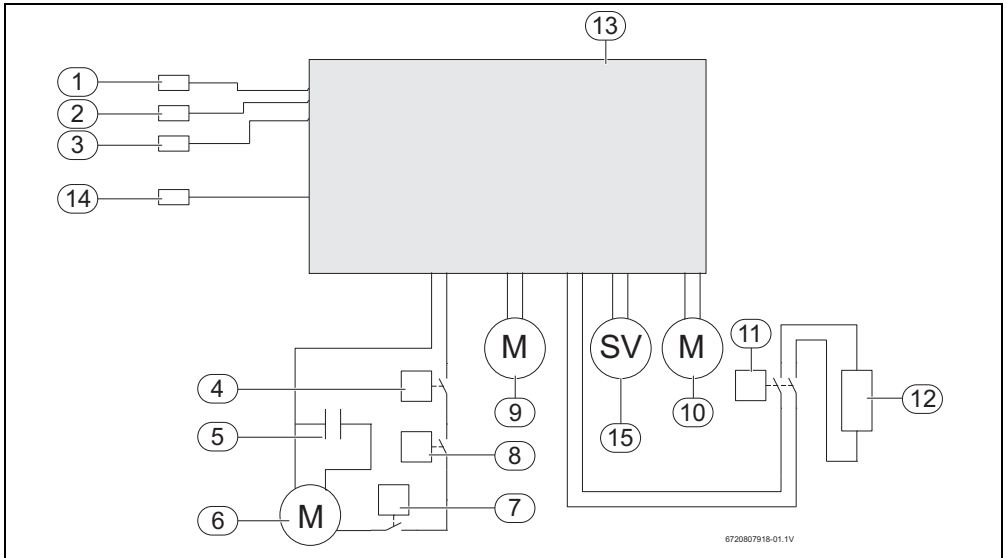

Fig. 72

- [1] Temperature sensor for air inlet
- [2] Storage tank temperature sensor for DHW
- [3] Storage tank temperature sensor for cold water
- [4] High-pressure pressure switch
- [5] Compressor startup capacitor
- [6] Compressor
- [7] Compressor thermal protector
- [8] Low-pressure pressure switch
- [9] DHW circulation pump
- [10] Air fan
- [11] Heating element thermal cut-out
- [12] Heating element
- [13] Control unit
- [14] Temperature sensor at evaporator fins
- [15] Solenoid valve

9 Environmental protection

Environmental protection is a basic company strategy of Bosch. The quality of our products, profitability and environmental protection are equal-ranking goals for us. Laws and regulations concerning environmental protection are strictly observed. We use the best possible technology and materials, under economic considerations, to protect the environment.

Packaging

We participate in the recycling program of the respective country to ensure optimal recycling. All of our packaging materials are environmental-friendly and can be recycled.

Old appliances

Old appliances contain valuable materials that should be recycled. The assemblies can be easily detached and synthetic materials are marked accordingly. The assemblies can therefore be sorted out and passed on for recycling or disposal.

At the end of the service life of this appliance and prior to its environmental disposal, a person qualified to work with refrigerant circuits must recover the refrigerant from within the sealed system.

**WARNING:**

The refrigerant must not be vented to the atmosphere.

10 Warranty details

Robert Bosch (Australia) Pty Ltd Thermotechnology Division

Voluntary Repair or Replacement Warranty for Bosch Heat Pump

All Bosch products are carefully checked, tested and certified to Australian and New Zealand standards.



Important Note: Mandatory Australian Consumer Law statement

If you have purchased your product in Australia, you should be aware that: This warranty is provided in addition to other rights and remedies held by a consumer at law. Our goods come with guarantees that cannot be excluded under the Australian Consumer Law. You are entitled to a replacement or refund for a major failure and for compensation for any other reasonably foreseeable loss or damage. You are also entitled to have the goods repaired or replaced if the goods fail to be of acceptable quality and the failure does not amount to a major failure.



Important Note: New Zealand law

If you have purchased your product in New Zealand, you should be aware that: This warranty is supplemental to any other rights and remedies you have under the Consumer Guarantees Act 1993 NZ, unless your purchase is made for commercial purposes, in which case Bosch excludes all consumer guarantees implied in the Consumer Guarantees Act 1993 NZ in respect of your product.

1. Warranty

Bosch warrants, at its option, to repair or replace your water heater or relevant part thereof (Product) if such Product are faulty or defective in manufacture or materials during the warranty period specified below.

The warranty period commences on the date of purchase. If the date of original purchase cannot be determined, then the warranty period will commence six (6) months after the date of manufacture stamped on the Product. Bosch may require evidence to verify the date of purchase.

This warranty only covers repair or replacement of defective Product (including labour costs where indicated). It does not cover:

- any costs incurred by the end user in normal or scheduled maintenance of the Product; or
- subject to any law to the contrary, any damage to property, personal injury, direct or indirect loss, consequential losses or other expenses arising from breach of this warranty. Any end user concerned with this exclusion should consider the "Important Note: Mandatory Australian Consumer Law statement" above.

2. Warranty periods & coverage

Bosch will provide warranty service for Product purchased and installed in Australia and New Zealand as follows:

Components	The period after purchase within which the fault must appear	What Bosch will do (see below for definitions)
Domestic Use (see below for definition)		
All components	Year 1 to 2	Parts & Labour
Water tank	Year 2 to 5	Parts only
Commercial Use (see below for definition)		
All components	Year 1 to 1	Parts & Labour
Water tank	Year 1 to 1	Parts only

Table 10

"Parts & Labour" means free of charge repair and/or replacement, including labour.

"Parts only" means a replacement heat exchanger, free of charge. All installation and repair labour costs are the responsibility of the owner.

"Domestic use" warranty period applies to Product installed to supply hot water for use by individuals in domestic dwellings. For Product used for all other uses, the commercial use warranty period will apply. This includes, without limitation, installations such as centralised or bulk hot systems, hotels, sporting complexes, caravan parks, laundry facilities, restaurants and cafes.

For "Parts only" warranty, the end user will be charged for service call costs and service technician fees in effecting the replacement.

For valid claims within "Parts & Labour" warranty periods, the end user will not be charged for costs associated with making a warranty claim, including service call costs, any service technician fees or the cost of replacement parts and freight, provided that:

- the Product is located within the usual operating area of an authorised service technician; and
- the Product has been installed according to the installation instructions so as to provide adequate service access.

If the Product is not located within the usual operating area of an authorised service technician, the end user will be required to pay the service call costs associated with a service call under this voluntary warranty.

Notwithstanding the above, if the Product has not been installed in accordance with the installation instructions in regards to access, or has been otherwise installed in location where service access is difficult, the end user will be required to pay charges associated with the difficult access. This includes, but is not limited to, the removal of walls or doors to gain access and the use of specialised equipment to move the Product or components to safe working levels. Where the Product cannot be safely accessed, Bosch may refuse to service the Product under this voluntary warranty.

For invalid claims under this voluntary warranty, the end user will be liable for the costs of making the warranty claim including any service call costs.

3. Warranty exclusions

This voluntary warranty is subject to the following conditions:

- The Product must have been installed and correctly commissioned by an authorised and licensed installer in compliance with applicable Australian Plumbing and Gas Standards. Proof may be required of correct commissioning of the Product (such as certificate of compliance). Claims for failures due to incorrect installation or commissioning are not covered under this voluntary warranty and may be rejected by Bosch.
- Where a Product or part thereof is replaced or repaired under this voluntary warranty, the balance of the original voluntary warranty will apply. The replacement Product or part does not carry a new voluntary warranty.
- The Product must have its original serial numbers and rating labels intact.
- The warranty does not extend to any Product that have been completely or partially disassembled.
- These warranty terms cannot be amended except in writing by an authorised officer of Bosch.
- The warranty only applies to Product installed for an end user in Australia or New Zealand and purchased from Bosch or from a reseller where the Product have been originally sold by Bosch.
- Any claim made under this voluntary warranty meets the requirements set out below in the "How to Make a Warranty Claim" section.

4. Warranty Exclusions

This warranty will not apply to a defect or fault to the extent to which it arises:

- due to storage, handling or installation of the Product otherwise than in accordance with instructions provided for the Product by Bosch or without reasonable care, including installation of a Product which is of inappropriate size or type for the intended purpose;
- due to operation, use or maintenance of the Product otherwise than in accordance with instructions provided for the Product by Bosch or without reasonable care, including use of the Product with faulty or unsuitable plumbing, water pressure, power or gas supply;
- due to accidental damage or use of the Product for a purpose or in environmental conditions for which the Product were not designed or sold, or use of the products outside the specified or normal operating ranges for such Product;
- as a result of changes which occur in the condition or operational qualities of the Product due to climate or other environmental influence, foreign material contamination or water entry or as a result of exposure to excessive heat or solvents or because of use of non-potable water or bore water in the Product or damage as result of an Act of Nature including but not limited to storms, fires, floods and lightning strikes;
- from normal wear and tear or when replacement or repair of parts would be part of normal maintenance or service of the Product or where the damage is only to surface coating, varnish or enamel;
- as a result of repairs, alterations or modifications to the Product which have been performed by a person who is not suitably qualified and experienced to perform works on the Product; or
- from the use of any spare parts not manufactured, sold or approved by Bosch in connection with the repair or replacement of Product.

This voluntary warranty does not apply to damage that has been caused by continued use of a Product after it is known, or would have been known with regular servicing, it is defective.

Failure to service Product in accordance with recommendations in instruction manuals for Product may result in a warranty claim under this voluntary warranty being rejected by Bosch. Bosch alerts end users that instruction manuals for Product contain specific recommendations for servicing and safety checks to be carried out on Product.

5. Wrong Deliveries and Transit Damage

Wrong deliveries, incorrect or damaged packing and transit damage claims are not warranty claims. Such cases should be

directed to Bosch's Customer Service line in Australia on ph: 1300 307 037 or in New Zealand on ph: 0800 543 352.

6. How to Make a Warranty Claim

If a Product fails within the warranty period, the end user must stop using the Product and make a claim as soon as possible, in any event before the end of the Warranty Period (see Deadlines for Submitting Warranty Claims below).

To make a warranty claim under this voluntary warranty, call the Bosch Customer Contact Centre (in Australia on ph: 1300 307 037 or in New Zealand on ph: 0800 543 352). Please be ready to provide the model and serial number, date of installation, purchase details and a full description of the problem. Alternatively, for claims in Australia, you can post details of your claim to Robert Bosch (Aust) Pty Ltd, Attn TT Warranty Department, Locked Bag 66, Clayton Sth, Victoria, 3169. Claims received by post will take longer to process and we encourage you to call. Bosch may refer you to one of its Bosch Warranty Authorised Service Dealers.

Proof of purchase and purchase date, as well as proof of installation and proper commissioning by a licensed installer, may be required by Bosch or an authorised service technician.

All warranty service calls will be conducted by an authorised service technician during normal business hours. Bosch will not accept claims under this voluntary warranty for attendance and repair of the Product by third parties not authorised by Bosch.

7. Deadlines for Submitting Warranty Claims

Bosch aims to rectify genuine quality problems as a priority. This is generally achieved by investigating why defective products have failed and by introducing immediate corrective action measures to prevent re-occurring warranty failures. It is therefore critical that all warranty claims are promptly submitted to Bosch as soon as the product fails, and in any event before the end of the warranty period.

8. Product Liability and Product Safety

Bosch should be informed immediately about any potential product safety concerns within and outside the warranty period. Bosch is well aware of its product liability and product safety obligations and responsibilities. It is our aim to ensure appropriate product safety standards are met in order to avoid injury, loss and damage caused by defects in any Product.

9. Privacy

Bosch is required to seek personal information from an end user who seeks to make a claim under this warranty.

Such personal information may be used by Bosch and/or any authorised service technician (who is authorised to process warranty claims and/or carry out warranty repairs on behalf of Bosch) for the purpose of processing such warranty claim and

also for the provision of customer support and further information about Bosch's products and services (**Purpose**).

If an end user does not wish to provide Bosch and/or its authorised service technician with personal information, Bosch may be unable to process the end user's warranty claim or to provide the end user with additional customer support, services and information.

Bosch is committed to protecting the privacy of personal information and will act in compliance with applicable privacy laws, including the National Privacy Principles under the Australian Privacy Act 1988 (Cth) (as amended) and New Zealand's Information Privacy Principles described in the Privacy Act 1993 (NZ).

Bosch takes security measures in order to protect any personal information collected in the warranty claim process against manipulation, loss, destruction, access by unauthorized persons or unauthorized disclosure.

Bosch will not disclose any personal information to third parties other than for the Purpose or except as required by law.

An end user has the right to access the personal information Bosch or its authorised service technician hold about them. The end user can request to see, change or modify the personal information held about them, or withdraw consent for its usage, by contacting Bosch at the Bosch Contact Details below.

10. Bosch Contact Details

This warranty is offered by Robert Bosch (Australia) Pty Ltd (ACN 004 315 628) of 1555 Centre Road, Clayton, Victoria 3168. Please call the Customer Contact Centre on 1300 30 70 37 in Australia or 0800 543 352 in New Zealand if you have any queries in relation to this warranty or contact us using the online form at www.bosch-climate.com.au.

Notes



6720809948

Robert Bosch (Australia) Pty Ltd
Thermotechnology Division
1555 Centre Road
Clayton Victoria 3168

Australia
Phone: 1300 30 70 37
Fax: 1300 30 70 38
www.bosch-climate.com.au

New Zealand
Phone: 0800 54 33 52
Fax: 0800 54 33 55
www.bosch-climate.co.nz