

VEVOR[®]

TOUGH TOOLS, HALF PRICE

Technical Support and E-Warranty Certificate www.vevor.com/support

LIVESTOCK TRIMMING STAND

USER MANUAL

We continue to be committed to provide you tools with competitive price.

"Save Half", "Half Price" or any other similar expressions used by us only represents an estimate of savings you might benefit from buying certain tools with us compared to the major top brands and does not necessarily mean to cover all categories of tools offered by us. You are kindly reminded to verify carefully when you are placing an order with us if you are actually saving half in comparison with the top major brands.

VEVOR[®]

TOUGH TOOLS, HALF PRICE

LIVESTOCK TRIMMING STAND

SCJ002-W /SCJ003-W /SCJ002-B /SCJ003-B



NEED HELP? CONTACT US!

Have product questions? Need technical support? Please feel free to contact us:

Technical Support and E-Warranty Certificate
www.vevor.com/support

This is the original instruction, please read all manual instructions carefully before operating. VEVOR reserves a clear interpretation of our user manual. The appearance of the product shall be subject to the product you received. Please forgive us that we won't inform you again if there are any technology or software updates on our product.

Safety precautions

WARNING:

Read this instructions before using this product. Failure to do so can result in serious injury. the basic precautions should always be followed,including the following:

1. The livestock trimming stand may not be used or stored in hazardous areas. It is not allowed to use the appliance in hazardous locations.
2. The livestock trimming stand must be checked to ensure that it is in proper working order and is operating safely prior to use. Otherwise,the appliance must not be used.
3. Use as intended only. The Livestock Trimming Stand needs to be placed on level ground for use. If necessary, the four feet can be secured with ground nails.
4. The operator must use the livestock trimming stand properly. He must consider the local conditions and must pay attention to third parties,in particular children,when working with the livestock trimming stand.
5. This livestock trimming stand is not intended for use by persons (including children) with reduced physical,sensory or mental abilities or lacking experience and/or knowledge,unless they are super- vised by a person responsible for their safety or are instructed by these persons on the use of the device. Children should be supervised,to ensure that they do not play with the livestock trimming stand.

SAVE THESE INSTRUCTIONS

Product List

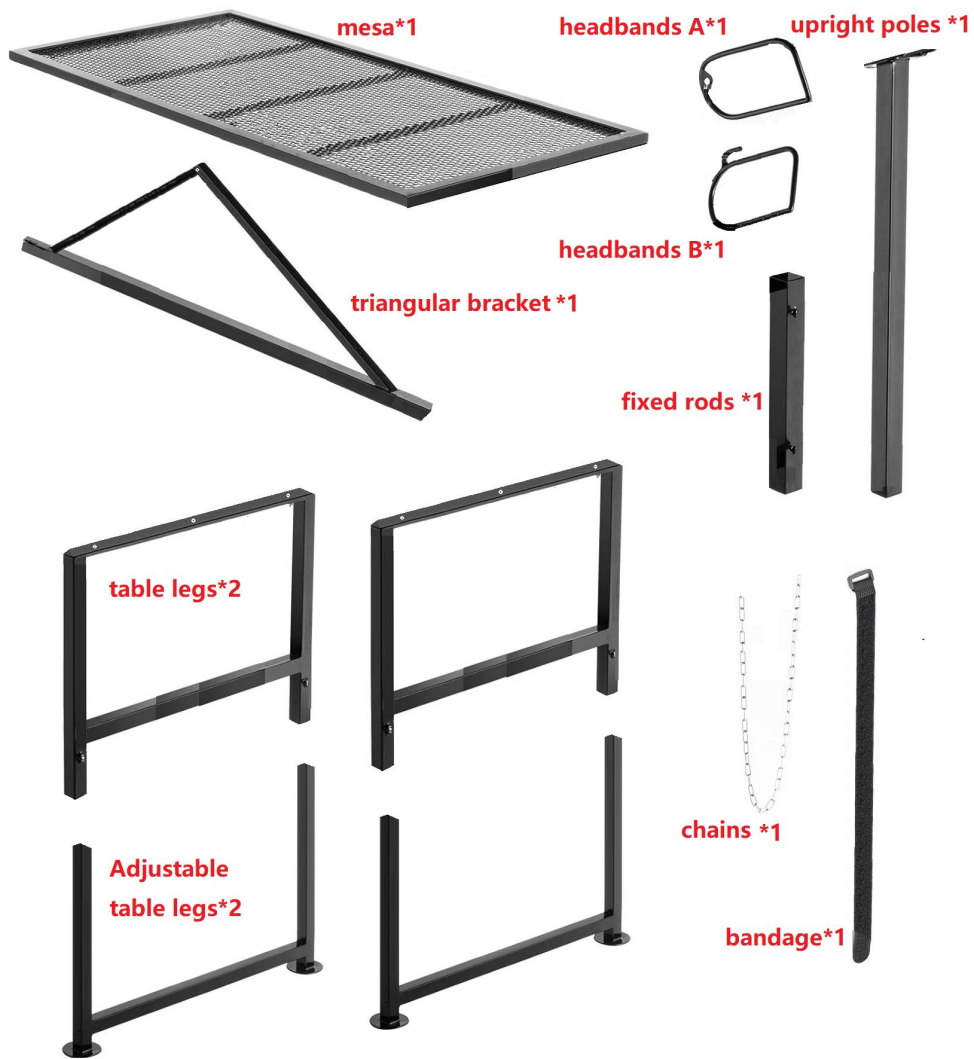



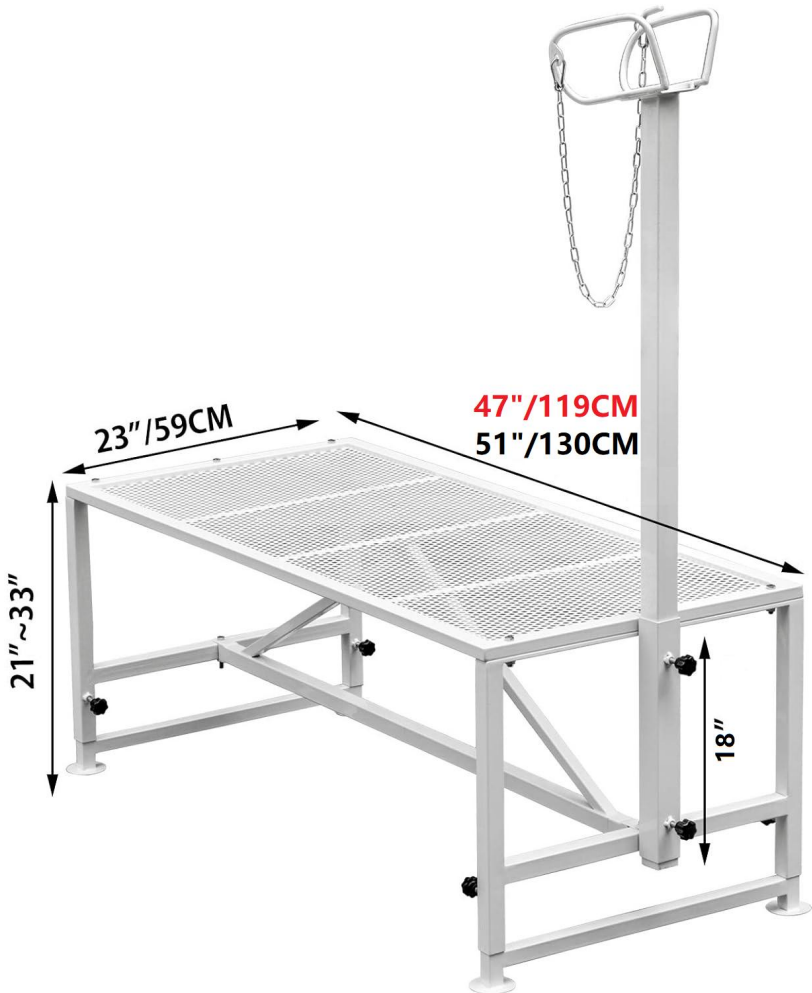

Product Description

Model	Colour	Table size	Adjustable height of the countertop	The upright rod adjusts the height	weight capacity
SCJ002-W	white	47*23inch	I 21in/533mm;	18in/457mm	500lbs
SCJ003-W	white	51*23inch	II 25in/635mm;		
SCJ002-B	black	47*23inch	III 29in/736mm;		
SCJ003-B	black	51*23inch	IV 33in/838mm;		

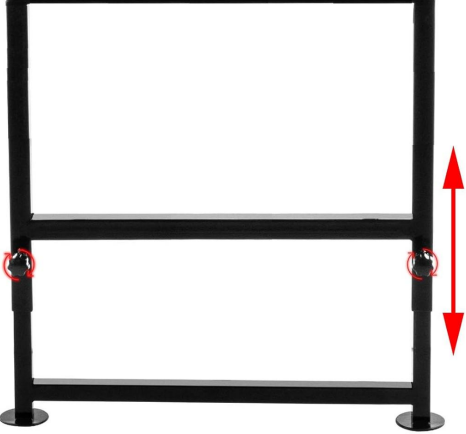
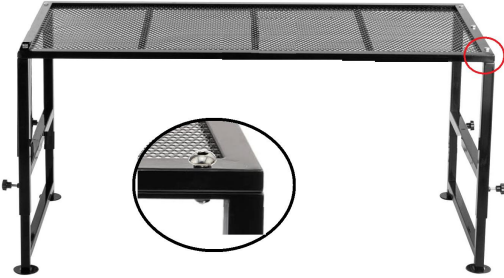

Installation Steps

Parts	Explanatory Chart	Explain
<p>table legs *2</p> <p>adjustable table legs *2</p> <p>plastic knobs *2</p>		<ol style="list-style-type: none"> 1. Insert the adjustable table leg into the table leg. 2. Secure the table leg with a plastic knob.
<p>M8x35 *5</p> <p>gasket *5</p> <p>M8 *5</p>		<ol style="list-style-type: none"> 1. Support the countertop with assembled table legs. 2. Thread 5 M8x35 holes through the table top, attach small spacers, and secure them with nuts.

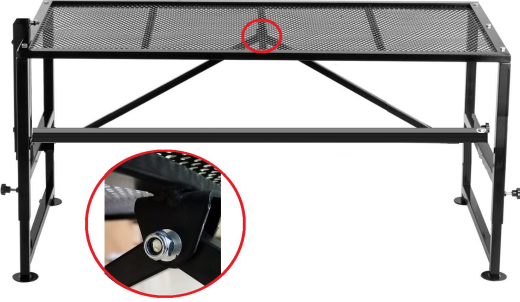
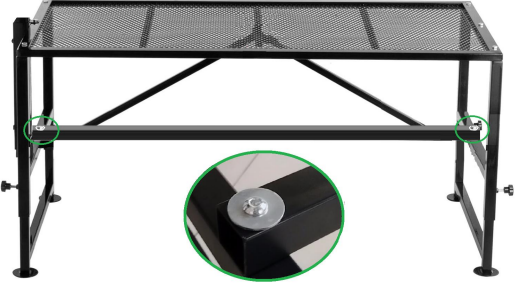
<p>fixed rods *1</p> <p>M8x35 *1</p> <p>gasket *1</p> <p>M8 *1</p>		<ol style="list-style-type: none"> 1. Jam the countertop with fixed rods and align the holes. 2. Thread 1 M8x35 through the hole of the fixed rods, attach the small spacer, and secure it with a nut.
<p>triangular bracket *1</p> <p>M8x35 *1</p> <p>gasket *1</p> <p>M8 *1</p>		<p>Thread 1 M8x35 screw through the middle hole of the triangle bracket and secure with spacers and nuts.</p>
<p>M8x70 *2</p> <p>big gasket *2</p> <p>M8 *2</p> <p>gasket *2</p>		<p>Thread 2 M8x70 screws through the large spacer, then through the holes on both sides of the triangle bracket and secure with the spacer and nut.</p>

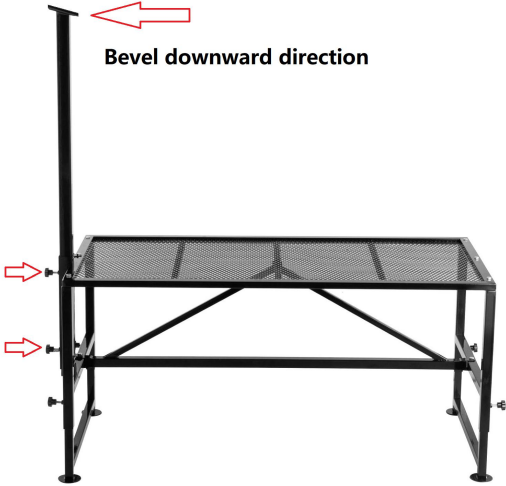
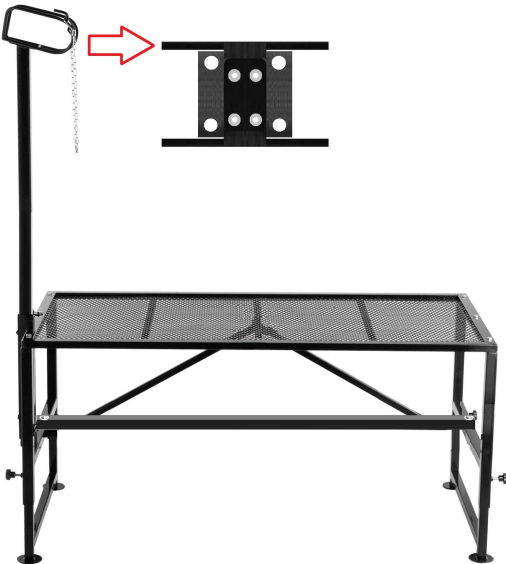
<p>upright poles *1</p> <p>plastic knobs *2</p>		<ol style="list-style-type: none"> 1. Insert the upright poles into the fixed rods square hole in the downward direction of the bevel. 2. Secure the upright poles with 2 plastic knobs.
<p>headbands A *1</p> <p>headbands B *1</p> <p>M6x20 *4</p> <p>M6 *4</p>		<ol style="list-style-type: none"> 1. Put the headbands B first. 2. Then put the headbands A. 3. Fix the headbands with 4 M6x20 screws. 4. Tighten the locking screws with 4 M6 nuts.

Product Usage

The height of the table corresponding to the four bolt hole gears.

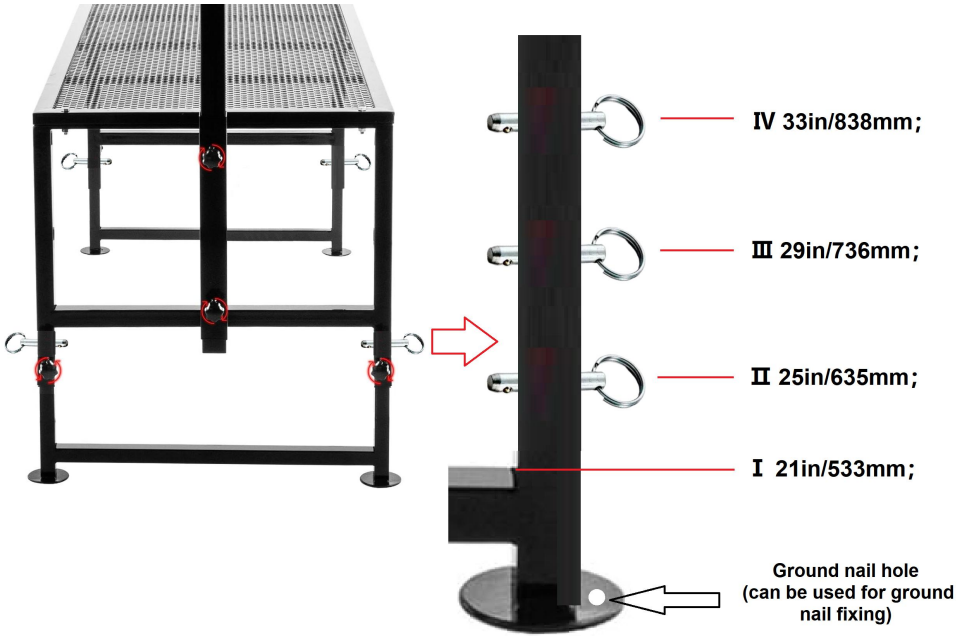

Manufacturer: Shanghaimuxinmuyeyouxiangongsi

Address: Baoshanqu Shuangchenglu 803long 11hao 1602A-1609shi
Shanghai

Imported to AUS: SIHAO PTY LTD, 1 ROKEVA STREETEASTWOOD
NSW 2122 Australia

Imported to USA: Sanven Technology Ltd., Suite 250, 9166 Anaheim
Place, Rancho Cucamonga, CA 91730

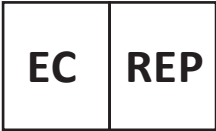

SHUNSHUN GmbH
Römeräcker 9 Z2021,76351
Linkenheim-Hochstetten,Germany
euvertreter@gmail.com
+49 1727041930



Pooledas Group Ltd
Unit 5 Albert Edward House, The
Pavilions Preston, United Kingdom
pooledas123@gmail.com
Tel: 01772418127

Made In China

VEVOR[®]

TOUGH TOOLS, HALF PRICE

Technical Support and E-Warranty Certificate

www.vevor.com/support

VEVOR[®]

TOUGH TOOLS, HALF PRICE

Techniczny Certyfikat wsparcia i e-gwarancji www.vevor.com/support

STANOWISKO DO PRZYCINANIA BYDŁA

INSTRUKCJA OBSŁUGI

We continue to be committed to provide you tools with competitive price.

"Save Half", "Half Price" or any other similar expressions used by us only represents an estimate of savings you might benefit from buying certain tools with us compared to the major top brands and does not necessarily mean to cover all categories of tools offered by us. You are kindly reminded to verify carefully when you are placing an order with us if you are actually saving half in comparison with the top major brands.

VEVOR®

TOUGH TOOLS, HALF PRICE

LIVESTOCK TRIMMING STAND

SCJ002-W /SCJ003-W /SCJ002-B /SCJ003-B



NEED HELP? CONTACT US!

Have product questions? Need technical support? Please feel free to contact us:

Technical Support and E-Warranty Certificate
www.vevor.com/support

This is the original instruction, please read all manual instructions carefully before operating. VEVOR reserves a clear interpretation of our user manual. The appearance of the product shall be subject to the product you received. Please forgive us that we won't inform you again if there are any technology or software updates on our product.

Środki ostrożności

OSTRZEŻENIE:

Przeczytaj tę instrukcję przed użyciem tego produktu. Niezastosowanie się do tego może spowodować poważne obrażenia. należy zawsze przestrzegać podstawowych środków ostrożności , w tym:

6. Stanowisko do przycinania bydła nie wolno używać ani przechowywać w obszarach niebezpiecznych. Nie wolno używać urządzenia w miejscach niebezpiecznych.
7. Stanowisko do przycinania bydła przed użyciem należy sprawdzić, czy jest w dobrym stanie i czy działa bezpiecznie. W przeciwnym razie nie wolno używać urządzenia.
8. Używaj wyłącznie zgodnie z przeznaczeniem. Przed użyciem stojak do przycinania zwierząt gospodarskich należy ustawić na równym podłożu. W razie potrzeby cztery nóżki można zabezpieczyć szlifowanymi gwoździami.
9. Operator musi korzystać ze stanowiska do przycinania zwierząt gospodarskich odpowiednio. Podczas pracy ze stanowiskiem do strzyżenia zwierząt gospodarskich musi on wziąć pod uwagę lokalne warunki i zwracać uwagę na osoby trzecie , w szczególności na dzieci .
10. To stanowisko do przycinania bydła nie jest przeznaczony do użytku przez osoby (w tym dzieci) o ograniczonych zdolnościach fizycznych , sensorycznych lub umysłowych lub nieposiadające doświadczenia i/lub wiedzy , chyba że znajdują się pod nadzorem osoby odpowiedzialnej za ich bezpieczeństwo lub zostaną przez te osoby poinstruowane w zakresie obsługi urządzenia. Dzieci powinny być nadzorowane , aby mieć pewność, że nie bawią się stanowiskiem do przycinania bydła .

ZACHOWAJ TE INSTRUKCJE

Lista produktów

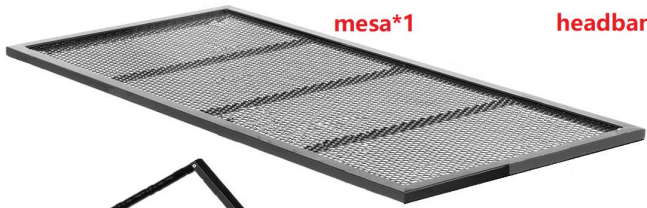

mesa*1

headbands A*1

upright poles *1



headbands B*1



fixed rods *1



triangular bracket *1



table legs*2



Adjustable table legs*2



chains *1



bandage*1

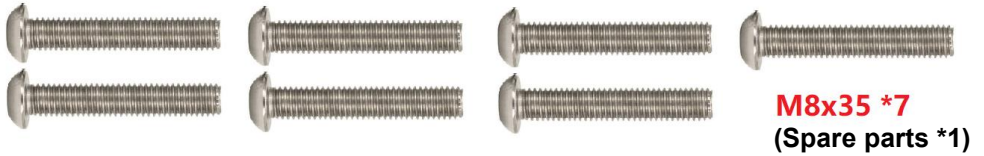

Opis produktu

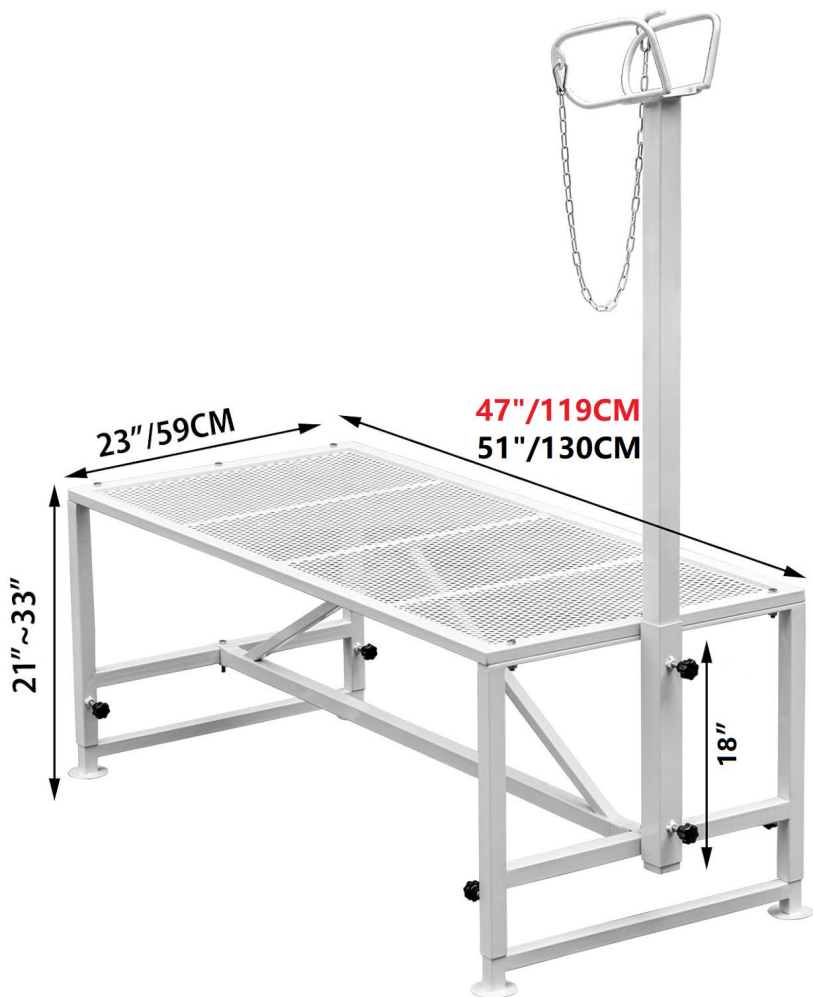

Model	Kolor	Rozmiar tabeli	Regulowana wysokość blatu	Pionowy drażek reguluje wysokość	udźwig
SCJ002-W	biały	47*23 cale	I 21 cali/533 mm; II 25 cali/635 mm; III 29 cali/736 mm; IV 33 cale/838 mm;	18 cali/457 mm	500 funtów
SCJ003-W	biały	51*23 cale			
SCJ002-B	czarny	47*23 cale			
SCJ003-B	czarny	51*23 cale			

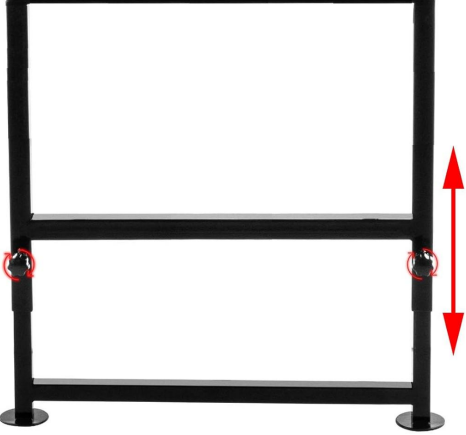
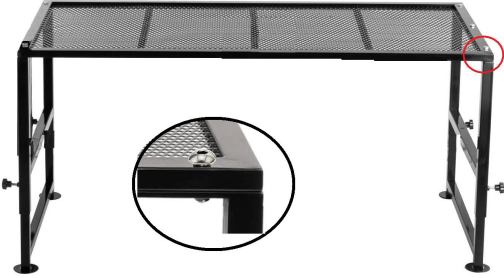

Kroki instalacji

Części _	Wykres wyjaśniający	Wyjaśnić _
----------	---------------------	------------

<p>nogi do stołu *2</p> <p>regulowane nogi stołu *2</p> <p>plastikowe gałki *2</p>		<p>3. Włóż regulowaną nogę stołu do nogi stołu.</p> <p>4. Zabezpiecz nogę stołu plastikową gałką.</p>
<p>M8x35 *5</p> <p>uszczelka *5</p> <p>M8*5</p>		<p>3. Podeprzyj blat za pomocą zmontowanych nóg stołu.</p> <p>4. Przewlec 5 otworów M8x35 przez blat stołu, przymocuj małe elementy dystansowe i zabezpiecz je nakrętkami.</p>

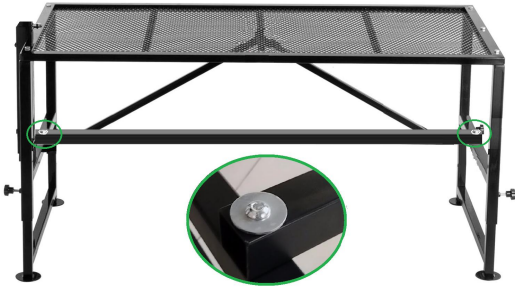
<p>stałe pręty *1</p> <p>M8x35 *1</p> <p>uszczelka *1</p> <p>M8*1</p>		<p>3. Zablokuj blat za pomocą stałych prętów i wyrównaj otwory.</p> <p>4. Przewlec 1 M8x35 przez otwór w prętach stałych, zamocuj małą podkładkę i zabezpiecz ją nakrętką.</p>
<p>wspornik trójkątny *1</p> <p>M8x35 *1</p> <p>uszczelka *1</p> <p>M8*1</p>		<p>Wkręć 1 śrubę M8x35 przez środkowy otwór wspornika trójkątnego i zabezpiecz przekładkami i nakrętkami.</p>
<p>M8x70 *2</p> <p>duża uszczelka *2</p> <p>M8*2</p> <p>uszczelka *2</p>		<p>Przewlec 2 śruby M8x70 przez dużą przekładkę, następnie przez otwory po obu stronach wspornika trójkątnego i zabezpiecz przekładką i nakrętką.</p>

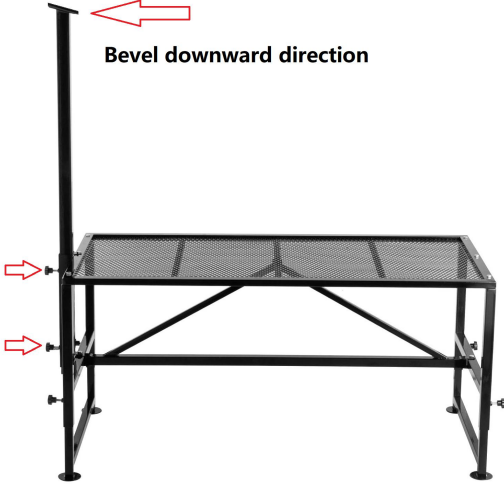
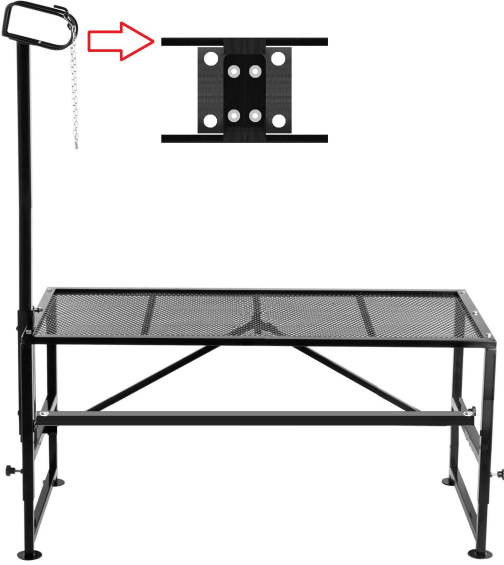
<p>słupki pionowe *1</p> <p>plastikowe gałki *2</p>		<p>3. Włóż pionowe słupki do kwadratowych otworów stałych prętów w kierunku skosu w dół.</p> <p>4. Zabezpiecz słupki pionowe za pomocą 2 plastikowych pokręteł.</p>
<p>opaski na głowę A *1</p> <p>opaski na głowę B *1</p> <p>M6x20 *4</p> <p>M6*4</p>		<p>5. Najpierw załóż opaski B.</p> <p>6. Następnie załóż opaski A.</p> <p>7. Przymocuj opaski za pomocą 4 śrub M6x20.</p> <p>8. Dokręć śruby zabezpieczające za pomocą 4 nakrętek M6.</p>

Użycie produktu

Wysokość stołu odpowiadająca czterem otworom na śruby koła zębate.

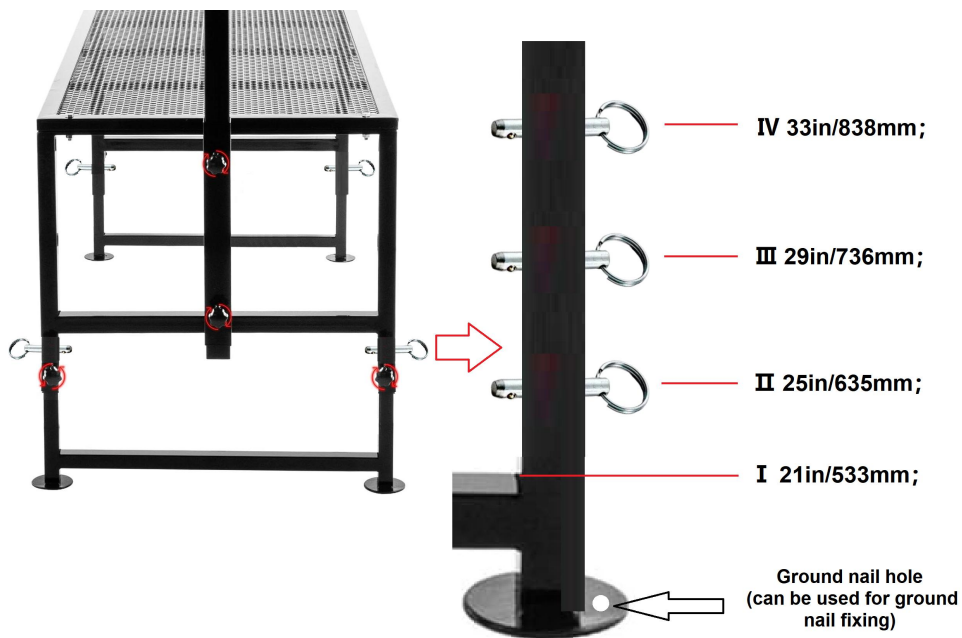

Producent: Shanghaimuxinmuyeyouxiangongsi

Adres: Baoshanqu Shuangchenglu 803long 11hao 1602A-1609shi
Szanghaj

Import do AUS: SIHAO PTY LTD, 1 ROKEVA STREETEASTWOOD NSW
2122 Australia

Import do USA: Sanven Technology Ltd., Suite 250, 9166 Anaheim Place,
Rancho Cucamonga, CA 91730



SHUNSHUN GmbH
Römeräcker 9 Z2021,76351
Linkenheim-Hochstetten, Germany
euvertreter@gmail.com
+49 1727041930



Pooledas Group Ltd
Unit 5 Albert Edward House, The
Pavilions Preston, United Kingdom
pooledas123@gmail.com
Tel: 01772418127

Wyprodukowano w Chinach

VEVOR[®]

TOUGH TOOLS, HALF PRICE

Techniczny Certyfikat wsparcia i e-gwarancji

www.vevor.com/support

VEVOR[®]

TOUGH TOOLS, HALF PRICE

Technisch Support- und E-Garantie-Zertifikat www.vevor.com/support

VIEHTRIMMSTAND

BENUTZERHANDBUCH

We continue to be committed to provide you tools with competitive price.

"Save Half", "Half Price" or any other similar expressions used by us only represents an estimate of savings you might benefit from buying certain tools with us compared to the major top brands and does not necessarily mean to cover all categories of tools offered by us. You are kindly reminded to verify carefully when you are placing an order with us if you are actually saving half in comparison with the top major brands.

VEVOR®

TOUGH TOOLS, HALF PRICE

LIVESTOCK TRIMMING STAND

SCJ002-W /SCJ003-W /SCJ002-B /SCJ003-B



NEED HELP? CONTACT US!

Have product questions? Need technical support? Please feel free to contact us:

Technical Support and E-Warranty Certificate
www.vevor.com/support

This is the original instruction, please read all manual instructions carefully before operating. VEVOR reserves a clear interpretation of our user manual. The appearance of the product shall be subject to the product you received. Please forgive us that we won't inform you again if there are any technology or software updates on our product.

Sicherheitsvorkehrungen

WARNUNG:

Lesen Sie diese Anweisungen, bevor Sie dieses Produkt verwenden.

Andernfalls kann es zu schweren Verletzungen kommen. Die grundlegenden Vorsichtsmaßnahmen sollten immer befolgt werden , einschließlich der folgenden:

11. Der Viehtrimmstand dürfen nicht in explosionsgefährdeten Bereichen verwendet oder gelagert werden. Es ist nicht gestattet, das Gerät in explosionsgefährdeten Bereichen zu verwenden.

12. Der Viehtrimmstand Vor der Verwendung muss überprüft werden, ob es ordnungsgemäß funktioniert und sicher funktioniert. Andernfalls darf das Gerät nicht verwendet werden.

13. Nur bestimmungsgemäß verwenden. Der Viehtrimmstand muss zur Verwendung auf einem ebenen Boden aufgestellt werden. Bei Bedarf können die vier Füße mit Erdnägeln befestigt werden.

14. Viehtrimmstand benutzen richtig. Er hat die örtlichen Gegebenheiten zu berücksichtigen und bei der Arbeit am Viehschneidestand Rücksicht auf Dritte , insbesondere Kinder , zu nehmen .

15. Dieser Viehtrimmstand ist nicht für den Gebrauch durch Personen (einschließlich Kinder) mit eingeschränkten körperlichen , sensorischen oder geistigen Fähigkeiten oder mangels Erfahrung und/oder mangels Wissen bestimmt , es sei denn, sie werden durch eine für ihre Sicherheit zuständige Person beaufsichtigt oder erhalten von dieser Person Anweisungen zum Gebrauch das Gerät. Kinder sollten beaufsichtigt werden , um sicherzustellen, dass sie nicht mit dem Viehtrimmstand spielen .

ANLEITUNG AUFBEWAHREN

Produktliste

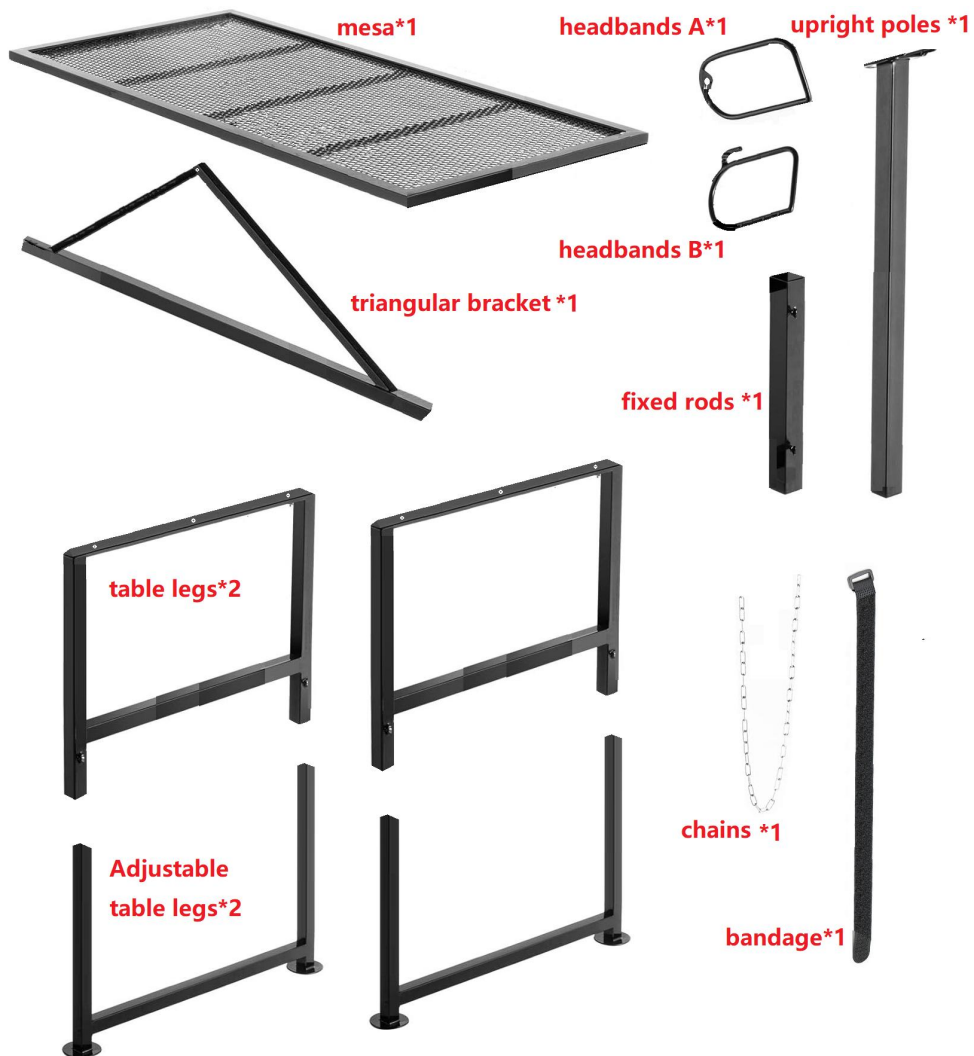

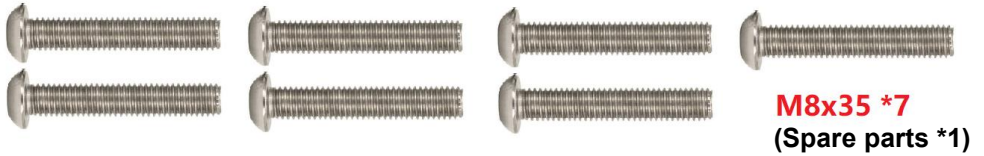

Produktbeschreibung

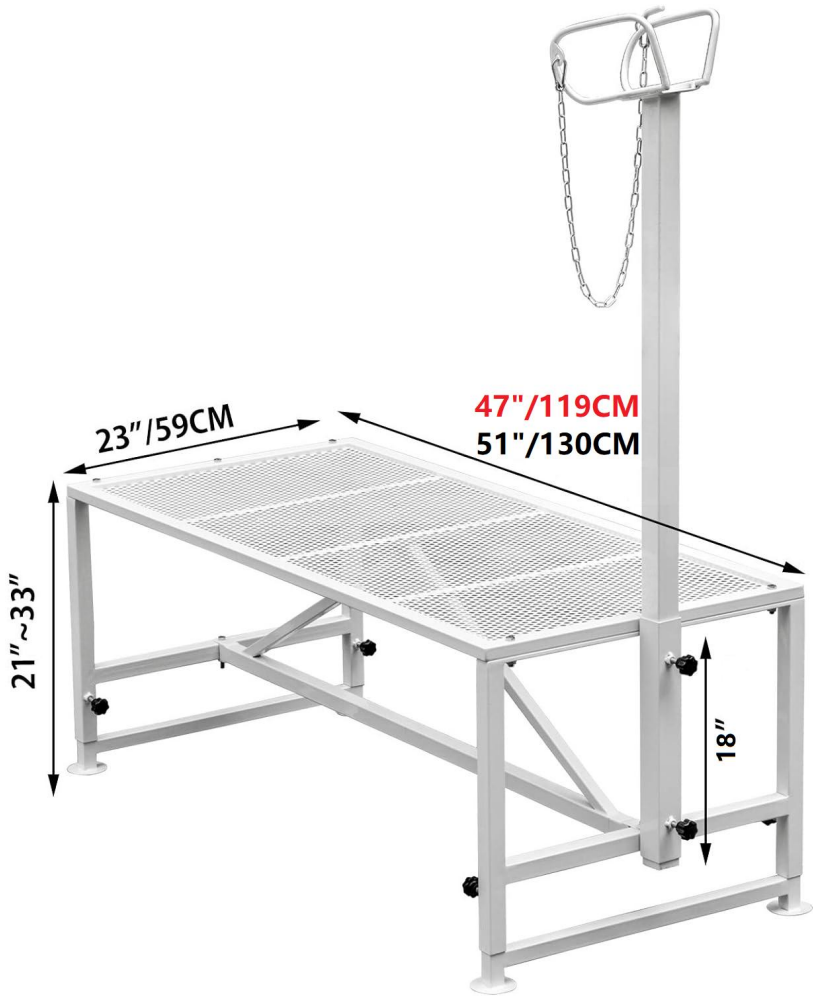

Modell	Farbe	Tischgröße	Höhenverstellbare Arbeitsplatte	Die aufrechte Stange verstellt die Höhe	Gewichtskapazität
SCJ002-W	Weiß	47 * 23 Zoll	I 21 Zoll/533 mm;	18 Zoll/457 mm	500 Pfund
SCJ003-W	Weiß	51*23 Zoll	II 25 Zoll/635 mm;		
SCJ002-B	Schwarz	47 * 23 Zoll	III 29 Zoll/736 mm;		
SCJ003-B	Schwarz	51*23 Zoll	IV 33 Zoll/838 mm;		

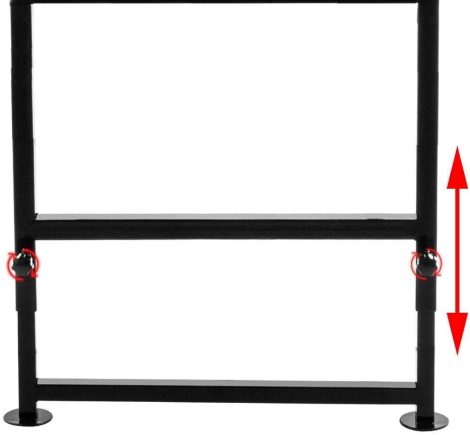
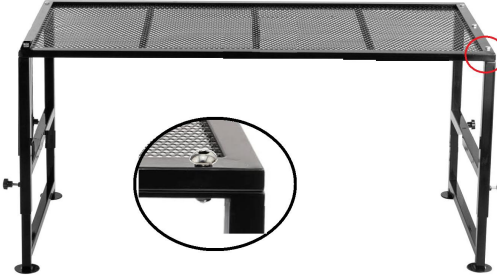

Installationsschritte

Teile _	Erläuterndes Diagramm	Erklären _
---------	-----------------------	------------

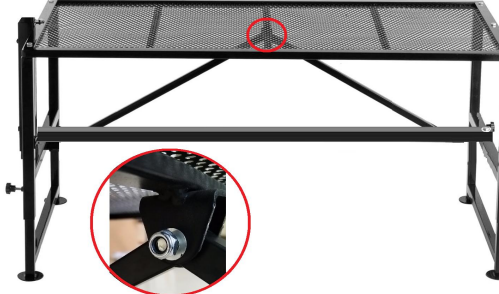
<p>Tischbeine *2</p> <p>verstellbare Tischbeine *2</p> <p>Kunststoffknöpfe *2</p>		<p>5. Stecken Sie das verstellbare Tischbein in das Tischbein.</p> <p>6. Befestigen Sie das Tischbein mit einem Kunststoffknopf.</p>
<p>M8x35 *5</p> <p>Dichtung *5</p> <p>M8 *5</p>		<p>5. Stützen Sie die Arbeitsplatte mit montierten Tischbeinen.</p> <p>6. Schrauben Sie 5 M8x35-Löcher durch die Tischplatte, bringen Sie kleine Abstandshalter an und befestigen Sie diese mit Muttern.</p>

<p>feste Stangen *1</p> <p>M8x35 *1</p> <p>Dichtung *1</p> <p>M8 *1</p>		<p>5. Klemmen Sie die Arbeitsplatte mit festen Stangen fest und richten Sie die Löcher aus.</p> <p>6. Fädeln Sie 1 M8x35 durch das Loch der festen Stangen, bringen Sie das kleine Distanzstück an und sichern Sie es mit einer Mutter.</p>
<p>Dreieckige Halterung *1</p> <p>M8x35 *1</p> <p>Dichtung *1</p> <p>M8 *1</p>		<p>Führen Sie eine M8x35-Schraube durch das mittlere Loch der Dreieckshalterung und befestigen Sie sie mit Distanzstücken und Muttern.</p>
<p>M8x70 *2</p> <p>große Dichtung *2</p> <p>M8 *2</p> <p>Dichtung *2</p>		<p>Führen Sie zwei M8x70-Schrauben durch den großen Abstandshalter, dann durch die Löcher auf beiden Seiten der Dreieckshalterung und befestigen Sie sie mit dem</p>

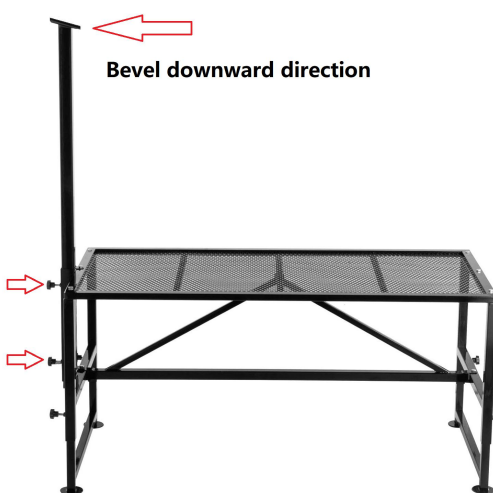
		Abstandshalter und der Mutter.
<p>aufrechte Stangen *1</p> <p>Kunststoffknöpfe *2</p>		<p>5. Führen Sie die aufrechten Stangen in der Abwärtsrichtung der Abschrägung in das quadratische Loch der festen Stangen ein.</p> <p>6. Sichern Sie die aufrechten Stangen mit 2 Kunststoffknöpfen.</p>

Stirnbänder A *1		9. Legen Sie zuerst die Stirnbänder B.
Stirnbänder B *1		10. Dann legen Sie die Stirnbänder A.
M6x20 *4		11. Befestigen Sie die Stirnbänder mit 4 Schrauben M6x20.
M6 *4		12. Ziehen Sie die Sicherungsschrauben mit 4 M6-Muttern fest.

Produktnutzung

Die Höhe des Tisches entspricht den vier Schraubenlöchern
 Getriebe.

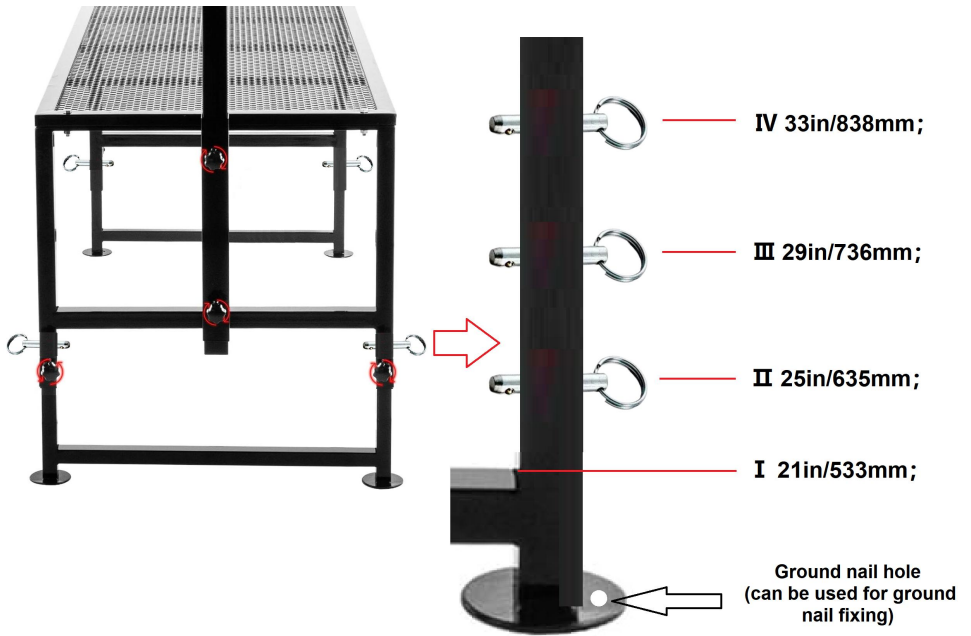

Hersteller: Shanghaimuxinmuyeyouxiangongsi

Adresse: Baoshanqu Shuangchenglu 803long 11hao 1602A-1609shi
Shanghai

Importiert nach AUS: SIHAO PTY LTD, 1 ROKEVA STREETEASTWOOD
NSW 2122 Australien

In die USA importiert: Sanven Technology Ltd., Suite 250, 9166 Anaheim
Place, Rancho Cucamonga, CA 91730

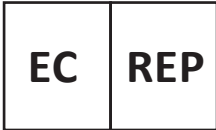

SHUNSHUN GmbH
Römeräcker 9 Z2021,76351
Linkenheim-Hochstetten, Germany
euvertreter@gmail.com
+49 1727041930



Pooledas Group Ltd
Unit 5 Albert Edward House, The
Pavilions Preston, United Kingdom
pooledas123@gmail.com
Tel: 01772418127

In China hergestellt

VEVOR[®]

TOUGH TOOLS, HALF PRICE

Technisch Support- und E-Garantiezertifikat

www.vevor.com/support

VEVOR[®]

TOUGH TOOLS, HALF PRICE

Technique Assistance et certificat de garantie électronique

www.vevor.com/support

SUPPORT DE PARAGE DU BÉTAIL

MANUEL DE L'UTILISATEUR

We continue to be committed to provide you tools with competitive price.

"Save Half", "Half Price" or any other similar expressions used by us only represents an estimate of savings you might benefit from buying certain tools with us compared to the major top brands and does not necessarily mean to cover all categories of tools offered by us. You are kindly reminded to verify carefully when you are placing an order with us if you are actually saving half in comparison with the top major brands.

VEVOR®

TOUGH TOOLS, HALF PRICE

LIVESTOCK TRIMMING STAND

SCJ002-W /SCJ003-W /SCJ002-B /SCJ003-B



NEED HELP? CONTACT US!

Have product questions? Need technical support? Please feel free to contact us:

Technical Support and E-Warranty Certificate
www.vevor.com/support

This is the original instruction, please read all manual instructions carefully before operating. VEVOR reserves a clear interpretation of our user manual. The appearance of the product shall be subject to the product you received. Please forgive us that we won't inform you again if there are any technology or software updates on our product.

Précautions de sécurité

AVERTISSEMENT:

Lisez ces instructions avant d'utiliser ce produit. Ne pas le faire peut entraîner des blessures graves. Les précautions de base doivent toujours être suivies, notamment les suivantes :

16. Le stand de parage du bétail ne peut pas être utilisé ou stocké dans des zones dangereuses. Il est interdit d'utiliser l'appareil dans des endroits dangereux.

17. Le stand de parage du bétail doit être vérifié pour s'assurer qu'il est en bon état de fonctionnement et qu'il fonctionne en toute sécurité avant utilisation. Dans le cas contraire, l'appareil ne doit pas être utilisé.

18. Utiliser uniquement comme prévu. Le support de parage du bétail doit être placé sur un sol plat pour être utilisé. Si nécessaire, les quatre pieds peuvent être fixés avec des clous de sol.

19. L'opérateur doit utiliser le support de parage du bétail correctement. Il doit tenir compte des conditions locales et faire attention aux tiers, en particulier aux enfants, lorsqu'il travaille avec le stand de parage du bétail.

20. Ce support de parage de bétail n'est pas destiné à être utilisé par des personnes (y compris des enfants) ayant des capacités physiques, sensorielles ou mentales réduites ou manquant d'expérience et/ou de connaissances, à moins qu'elles ne soient supervisées par une personne responsable de leur sécurité ou qu'elles ne soient instruites par ces personnes sur l'utilisation de le dispositif. Les enfants doivent être surveillés pour s'assurer qu'ils ne jouent pas avec le support de parage du bétail.

CONSERVEZ CES INSTRUCTIONS

Liste de produits

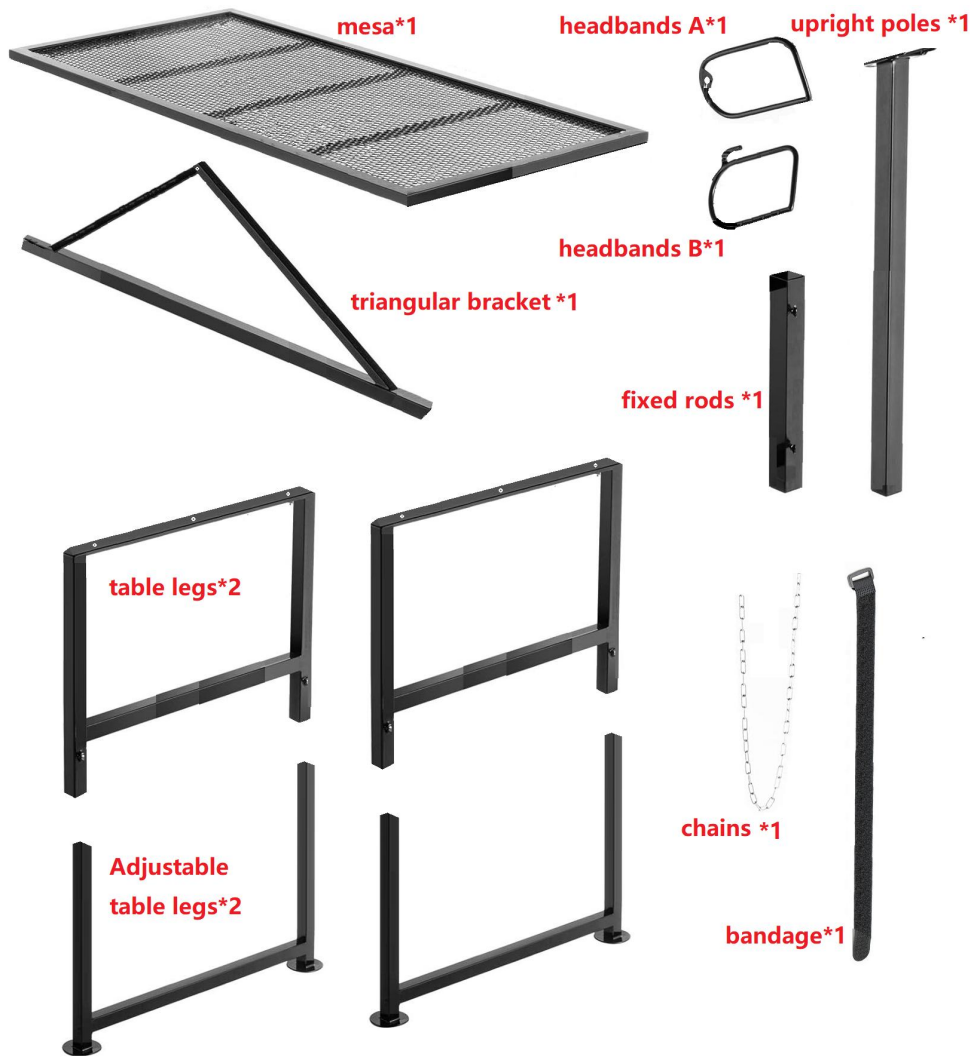





Description du produit

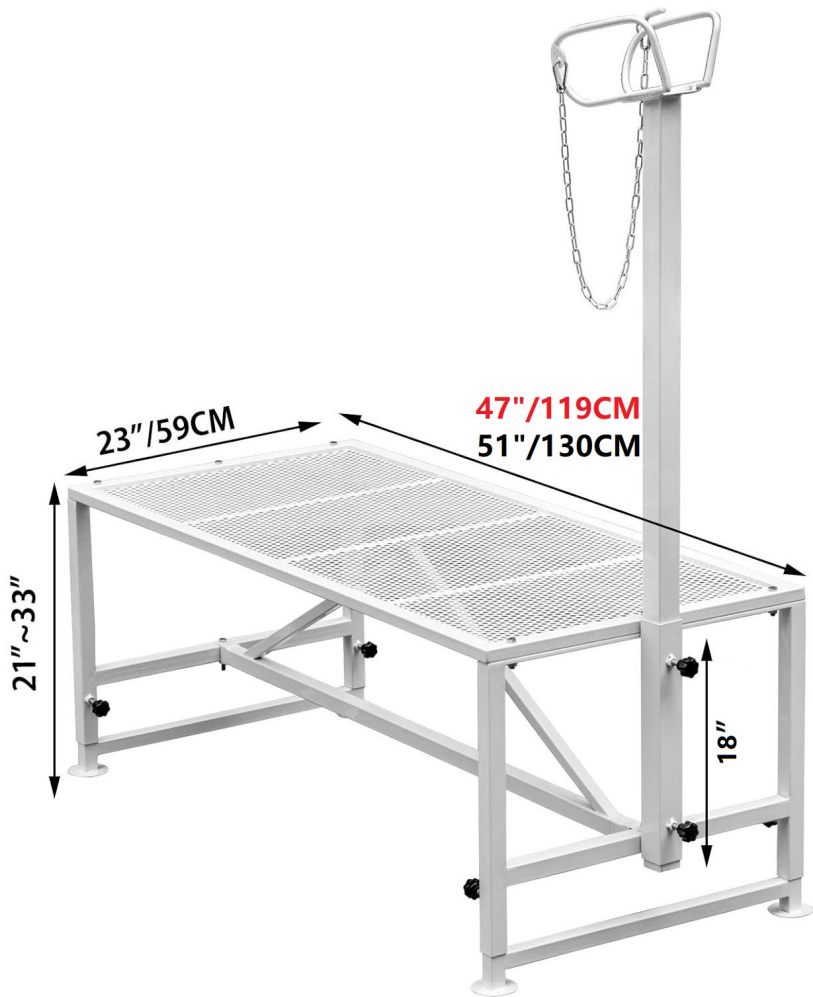

Modèle	Couleur	Taille du tableau	Hauteur du comptoir réglable	La tige verticale ajuste la hauteur	capacité de poids
SCJ002-W	blanc	47*23 pouces	I 21 pouces/533 mm ; II 25 pouces/635 mm ; III 29 pouces/736 mm ; IV 33 pouces/838 mm ;	18 pouces/457 mm	500 livres
SCJ003-W	blanc	51*23 pouces			
SCJ002-B	noir	47*23 pouces			
SCJ003-B	noir	51*23 pouces			

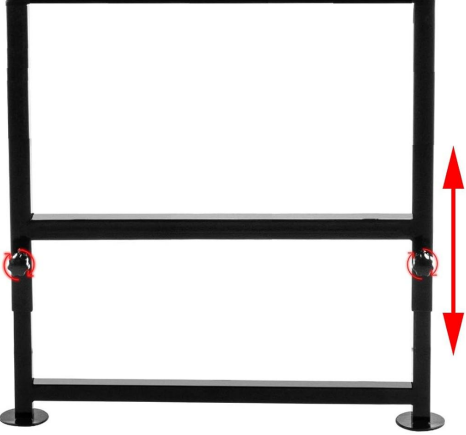

Étapes d'installation

Les pièces	Tableau explicatif	Expliquer _
------------	--------------------	-------------

<p>pieds de table * 2</p> <p>pieds de table réglables * 2</p> <p>boutons en plastique *</p> <p>2</p>		<p>7. Insérez le pied de table réglable dans le pied de table.</p> <p>8. Fixez le pied de table avec un bouton en plastique.</p>
<p>M8x35 *5</p> <p>joint *5</p> <p>M8 *5</p>		<p>7. Soutenez le comptoir avec les pieds de table assemblés.</p> <p>8. Vissez 5 trous M8x35 à travers le plateau de table, fixez de petites entretoises et fixez-les avec des écrous.</p>

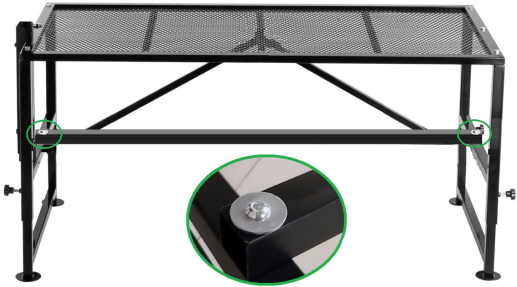
<p>tiges fixes * 1</p> <p>M8x35 *1</p> <p>joint *1</p> <p>M8 *1</p>		<p>7. Bloquez le comptoir avec des tiges fixes et alignez les trous.</p> <p>8. Enfilez 1 M8x35 dans le trou des tiges fixes, fixez la petite entretoise et fixez-la avec un écrou.</p>
<p>support triangulaire * 1</p> <p>M8x35 *1</p> <p>joint *1</p> <p>M8 *1</p>		<p>Enfilez 1 vis M8x35 dans le trou central du support triangulaire et fixez-la avec des entretoises et des écrous.</p>
<p>M8x70 *2</p> <p>gros joint *2</p> <p>M8 *2</p> <p>joint *2</p>		<p>Enfilez 2 vis M8x70 dans la grande entretoise, puis dans les trous des deux côtés du support triangulaire et fixez-les avec l'entretoise et l'écrou.</p>

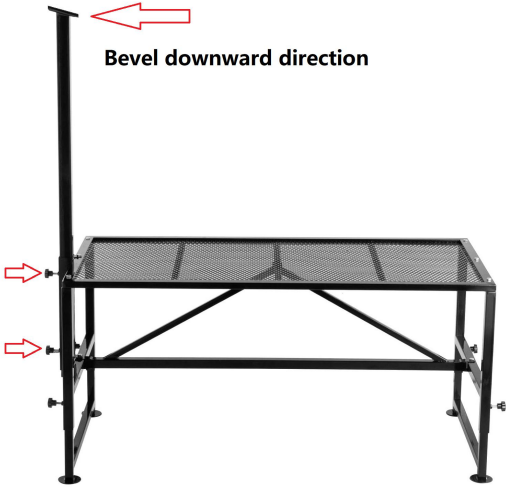
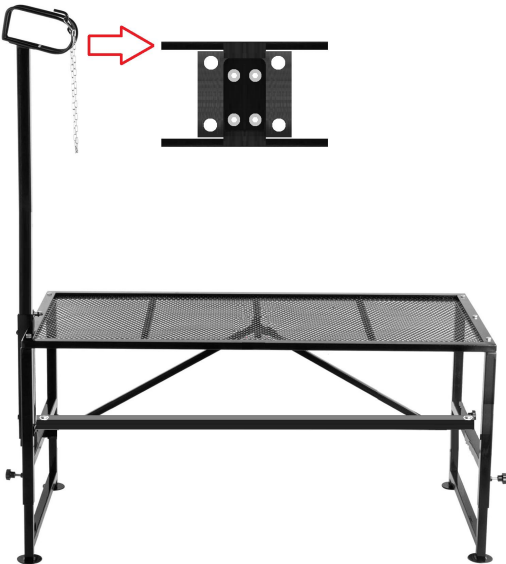
<p>poteaux verticaux *1</p> <p>boutons en plastique * 2</p>		<p>7. Insérez les poteaux verticaux dans le trou carré des tiges fixes dans la direction vers le bas du biseau.</p> <p>8. Fixez les poteaux verticaux avec 2 boutons en plastique.</p>
<p>bandeaux A * 1</p> <p>bandeaux B * 1</p> <p>M6x20 *4</p> <p>M6 *4</p>		<p>13. Mettez les bandeaux B en premier.</p> <p>14. Mettez ensuite les bandeaux A.</p> <p>15. Fixez les bandeaux avec 4 vis M6x20.</p> <p>16. Serrez les vis de verrouillage avec 4 écrous M6.</p>

Utilisation du produit

La hauteur de la table correspondant au trou des quatre boulons engrenages.

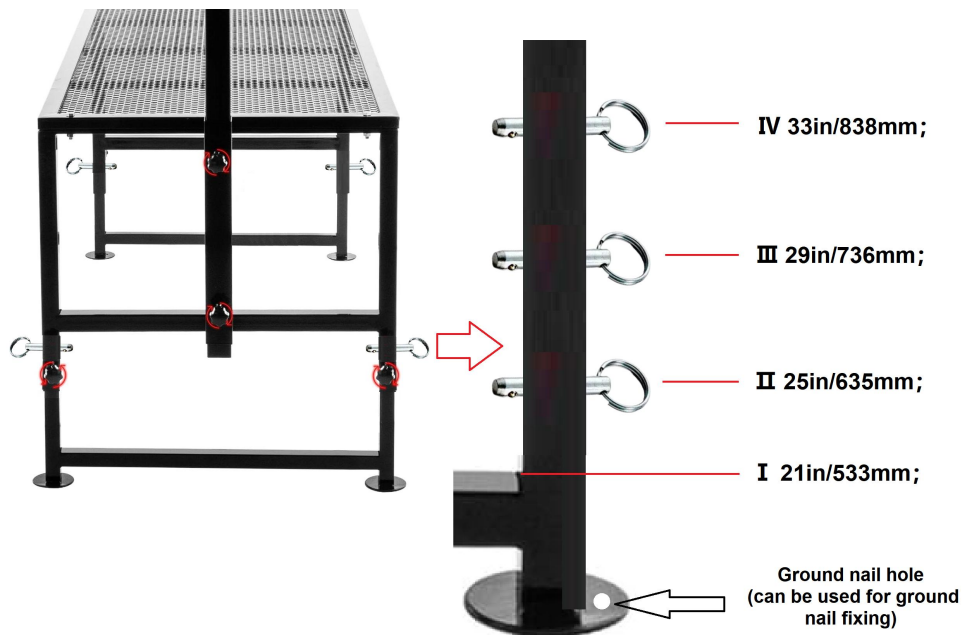



Fabricant : Shanghai muxinmuyeyouxiangongsi

Adresse : Baoshanqu Shuangchenglu 803long 11hao 1602A-1609shi
Shanghai

Importé en Australie : SIHAO PTY LTD, 1 ROKEVA STREETASTWOOD
NSW 2122 Australie

Importé aux États-Unis : Sanven Technology Ltd., Suite 250, 9166
Anaheim Place, Rancho Cucamonga, CA 91730



SHUNSHUN GmbH
Römeräcker 9 Z2021,76351
Linkenheim-Hochstetten, Germany
euvertreter@gmail.com
+49 1727041930



Pooledas Group Ltd
Unit 5 Albert Edward House, The
Pavilions Preston, United Kingdom
pooledas123@gmail.com
Tel: 01772418127

Fabriqué en Chine

VEVOR®

TOUGH TOOLS, HALF PRICE

Technique Assistance et certificat de garantie électronique

www.vevor.com/support

VEVOR[®]

TOUGH TOOLS, HALF PRICE

Technisch Ondersteuning en e-garantiecertificaat www.vevor.com/support

STAND VOOR HET TRIMMEN VAN VEE

HANDLEIDING

We continue to be committed to provide you tools with competitive price.

"Save Half", "Half Price" or any other similar expressions used by us only represents an estimate of savings you might benefit from buying certain tools with us compared to the major top brands and does not necessarily mean to cover all categories of tools offered by us. You are kindly reminded to verify carefully when you are placing an order with us if you are actually saving half in comparison with the top major brands.

VEVOR®

TOUGH TOOLS, HALF PRICE

LIVESTOCK TRIMMING STAND

SCJ002-W /SCJ003-W /SCJ002-B /SCJ003-B



NEED HELP? CONTACT US!

Have product questions? Need technical support? Please feel free to contact us:

Technical Support and E-Warranty Certificate
www.vevor.com/support

This is the original instruction, please read all manual instructions carefully before operating. VEVOR reserves a clear interpretation of our user manual. The appearance of the product shall be subject to the product you received. Please forgive us that we won't inform you again if there are any technology or software updates on our product.

Veiligheidsmaatregelen

WAARSCHUWING:

Lees deze instructies voordat u dit product gebruikt. Als u dit niet doet, kan dit leiden tot ernstig letsel. de basisvoorzorgsmaatregelen moeten altijd worden gevolgd , waaronder de volgende:

21. De stand voor het trimmen van vee mag niet worden gebruikt of opgeslagen in gevaarlijke gebieden. Het is niet toegestaan het apparaat op gevaarlijke locaties te gebruiken.

22. De stand voor het trimmen van vee moet vóór gebruik worden gecontroleerd om er zeker van te zijn dat deze in goede staat verkeert en veilig werkt. Anders mag het apparaat niet worden gebruikt.

23. Alleen gebruiken zoals bedoeld. De Livestock Trimming Stand moet voor gebruik op een vlakke ondergrond worden geplaatst. Indien nodig kunnen de vier poten vastgezet worden met grondspijkers.

24. De operator moet de veesnijstandaard gebruiken op de juiste manier. Hij moet rekening houden met de plaatselijke omstandigheden en moet bij het werken met de veesnijstand rekening houden met derden , in het bijzonder kinderen .

25. Deze stand voor het trimmen van vee is niet bedoeld voor gebruik door personen (inclusief kinderen) met verminderde lichamelijke , zintuiglijke of geestelijke vermogens of gebrek aan ervaring en/of kennis , tenzij zij onder toezicht staan van een persoon die verantwoordelijk is voor hun veiligheid of door deze personen zijn geïnstrueerd over het gebruik van het apparaat. Op kinderen moet toezicht worden gehouden , om er zeker van te zijn dat ze niet met de veetrimstandaard spelen .

BEWAAR DEZE INSTRUCTIES

Product lijst

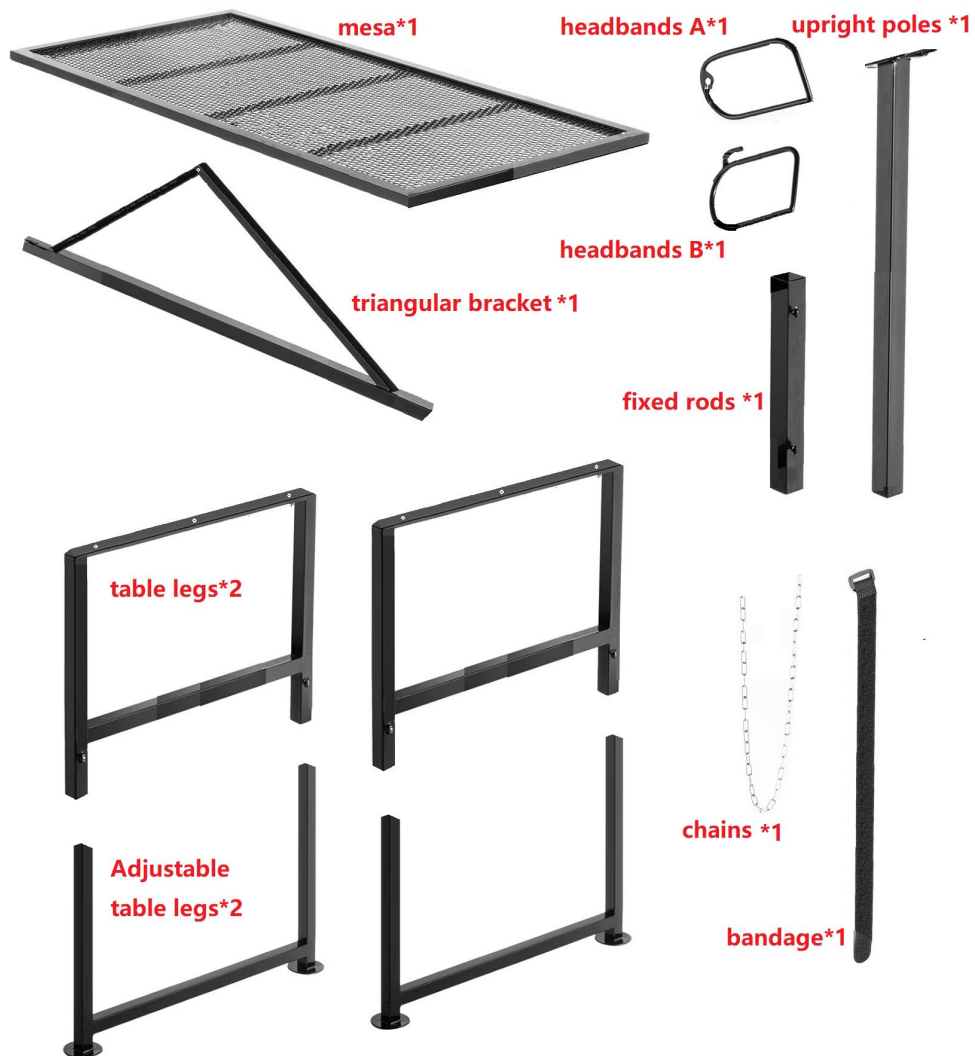



Plastic knobs *6



M8x70 *2



Big gasket *2

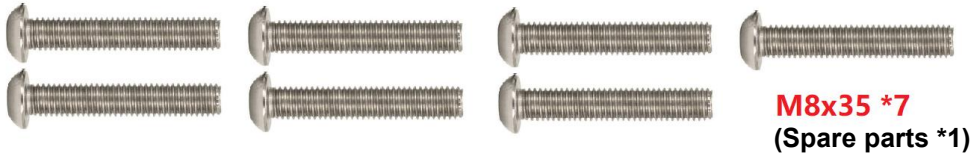

**M8x35 *7
(Spare parts *1)**



**M8 *7
(Spare parts *1)**



**gasket *9
(Spare parts *1)**



M6x20 *4



M6 *4



Bolt *4

Productomschrijving

Model	Kleur	Tafelgrootte	Verstelbare hoogte van het aanrecht	De rechtopstaande stang verstelt de hoogte	draagvermogen
SCJ002-W	wit	47*23 inch	I 21 inch/533 mm; II 25 inch/635 mm; III 29 inch/736 mm; IV 33in/838mm;	18 inch/457 mm	500 pond
SCJ003-W	wit	51*23 inch			
SCJ002-B	zwart	47*23 inch			
SCJ003-B	zwart	51*23 inch			

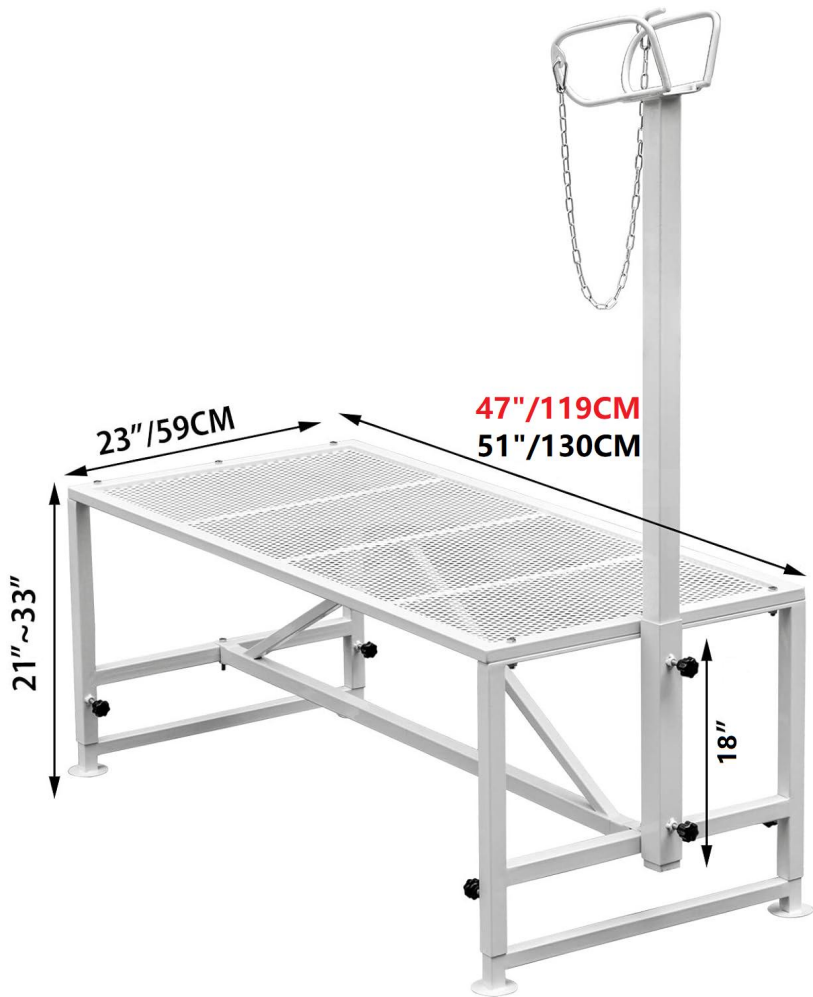



Installatiestappen

Onderdelen _

Verklarende grafiek

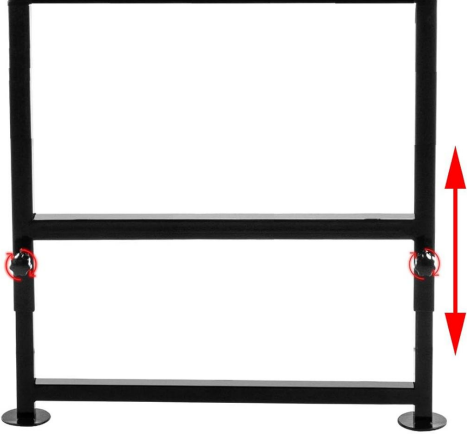
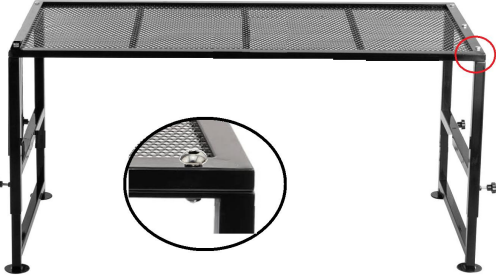
Uitleggen _

<p>tafelpoten *2</p> <p>verstelbare tafelpoten *2</p> <p>kunststof knoppen *2</p>		<p>9. Steek de verstelbare tafelpoot in de tafelpoot.</p> <p>10. Zet de tafelpoot vast met een plastic knop.</p>
<p>M8x35 *5</p> <p>pakking *5</p> <p>M8 *5</p>		<p>9. Ondersteun het aanrecht met gemonteerde tafelpoten.</p> <p>10. Rijg 5 M8x35 gaten door het tafelblad, bevestig kleine afstandshouders en zet ze vast met moeren.</p>

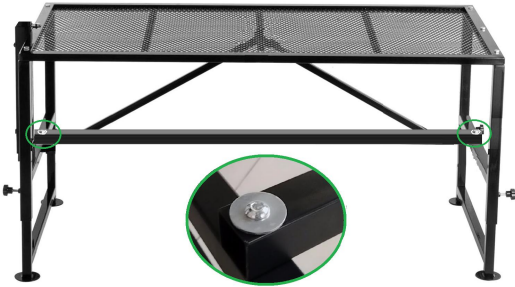
<p>vaste staven *1</p> <p>M8x35 *1</p> <p>pakking *1</p> <p>M8 *1</p>		<p>9. Zet het aanrecht vast met vaste stangen en lijn de gaten uit.</p> <p>10. Steek 1 M8x35 door het gat van de vaste stangen, bevestig het kleine afstandsstuk en zet het vast met een moer.</p>
<p>driehoekige beugel *1</p> <p>M8x35 *1</p> <p>pakking *1</p> <p>M8 *1</p>		<p>Draai 1 M8x35-schroef door het middelste gat van de driehoekige beugel en zet deze vast met afstandshouders en moeren.</p>
<p>M8x70 *2</p> <p>grote pakking *2</p> <p>M8 *2</p> <p>pakking *2</p>		<p>Steek 2 M8x70-schroeven door het grote afstandsstuk en vervolgens door de gaten aan beide zijden van de driehoekige beugel en zet het vast met het</p>

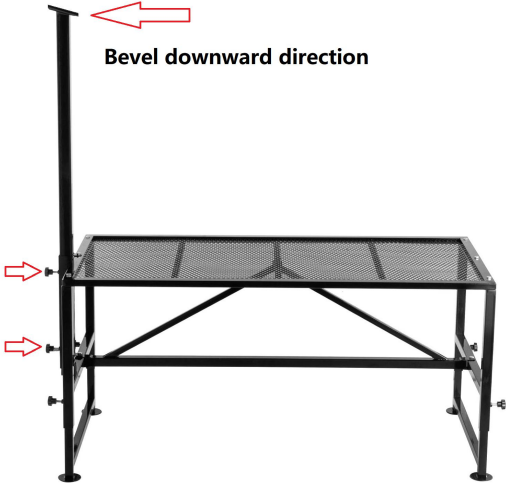
		afstandsstuk en de moer.
<p>rechtopstaande palen *1</p> <p>kunststof knoppen *2</p>		<p>9. Steek de rechtopstaande palen in het vierkante gat van de vaste stangen in de neerwaartse richting van de afschuining.</p> <p>10. Zet de rechtopstaande palen vast met 2 plastic knoppen.</p>

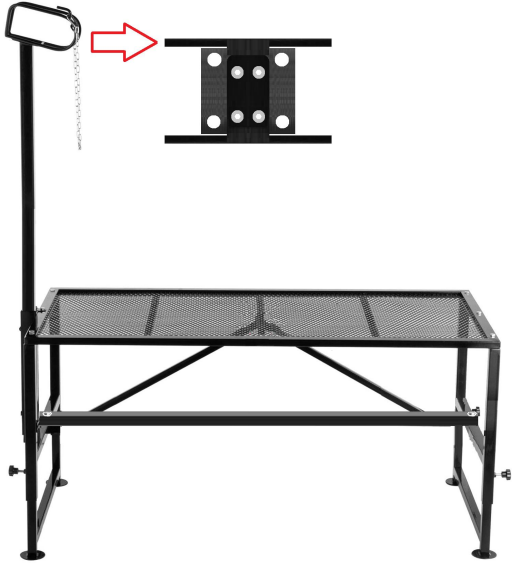
<p>hoofdbanden A *1</p> <p>hoofdbanden B *1</p> <p>M6x20 *4</p> <p>M6 *4</p>		<p>17. Plaats eerst de hoofdbanden B.</p> <p>18. Plaats vervolgens de hoofdbanden A.</p> <p>19. Bevestig de hoofdbanden met 4 M6x20 schroeven.</p> <p>20. Draai de borgschroeven vast met 4 M6-moeren.</p>
--------------------------------------------------------------------------------------	-----------------------------------------------------------------------------------	------------------------------------------------------------------------------------------------------------------------------------------------------------------------------------------------------------

Productgebruik

De hoogte van de tafel komt overeen met het vier boutgat versnellingen.

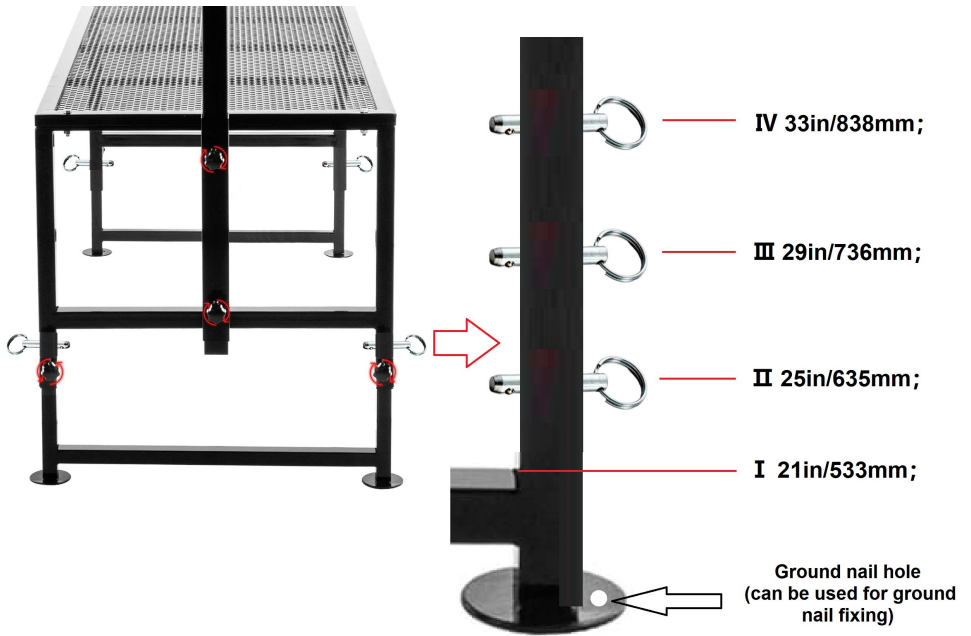

Fabrikant: Shanghaimuxinmuyeyouxiangongsi

Adres: Baoshanqu Shuangchenglu 803long 11hao 1602A-1609shi
Shanghai

Geïmporteerd naar AUS: SIHAO PTY LTD, 1 ROKEVA
STREETEASTWOOD NSW 2122 Australië

Geïmporteerd naar de VS: Sanven Technology Ltd., Suite 250, 9166
Anaheim Place, Rancho Cucamonga, CA 91730



SHUNSHUN GmbH
Römeräcker 9 Z2021,76351
Linkenheim-Hochstetten, Germany
euvertreter@gmail.com
+49 1727041930



Pooledas Group Ltd
Unit 5 Albert Edward House, The
Pavilions Preston, United Kingdom
pooledas123@gmail.com
Tel: 01772418127

Gemaakt in China

VEVOR[®]

TOUGH TOOLS, HALF PRICE

Technisch Ondersteuning en e-garantiecertificaat

www.vevor.com/support

VEVOR®

TOUGH TOOLS, HALF PRICE

Teknisk Support och e-garanticertifikat www.vevor.com/support

TRIMSTÄLL FÖR BOSKAP

ANVÄNDARMANUAL

We continue to be committed to provide you tools with competitive price.

"Save Half", "Half Price" or any other similar expressions used by us only represents an estimate of savings you might benefit from buying certain tools with us compared to the major top brands and does not necessarily mean to cover all categories of tools offered by us. You are kindly reminded to verify carefully when you are placing an order with us if you are actually saving half in comparison with the top major brands.

VEVOR[®]

TOUGH TOOLS, HALF PRICE

LIVESTOCK TRIMMING STAND

SCJ002-W /SCJ003-W /SCJ002-B /SCJ003-B



NEED HELP? CONTACT US!

Have product questions? Need technical support? Please feel free to contact us:

Technical Support and E-Warranty Certificate
www.vevor.com/support

This is the original instruction, please read all manual instructions carefully before operating. VEVOR reserves a clear interpretation of our user manual. The appearance of the product shall be subject to the product you received. Please forgive us that we won't inform you again if there are any technology or software updates on our product.

Säkerhetsåtgärder

VARNING:

Läs dessa instruktioner innan du använder denna produkt. Underlåtenhet att göra det kan resultera i allvarliga skador. de grundläggande försiktighetsåtgärderna bör alltid följas, inklusive följande:

26. Boskapsklippningsstället _ får inte användas eller förvaras i farliga områden. Det är inte tillåtet att använda apparaten på farliga platser.

27. Boskapsklippningsstället _ måste kontrolleras för att säkerställa att den är i korrekt fungerande skick och fungerar säkert före användning. I annat fall får apparaten inte användas .

28. Använd endast som avsett. Boskapsklippningsstället måste placeras på plan mark för användning. Vid behov kan de fyra fötterna säkras med markspikar.

29. Operatören måste använda boskapsklippningsstället ordentligt. Han måste ta hänsyn till de lokala förhållandena och vara uppmärksam på tredje part, särskilt barn , när han arbetar med boskapsklippningsstället .

30. Detta boskapsklippningsställ är inte avsedd att användas av personer (inklusive barn) med nedsatta fysiska, sensoriska eller mentala förmågor eller som saknar erfarenhet och/eller kunskap , såvida de inte övervakas av en person som ansvarar för deras säkerhet eller instrueras av dessa personer om användningen av enheten. Barn bör övervakas för att säkerställa att de inte leker med boskapsklippningsstället .

SPARA DESSA INSTRUKTIONER

Produktlista

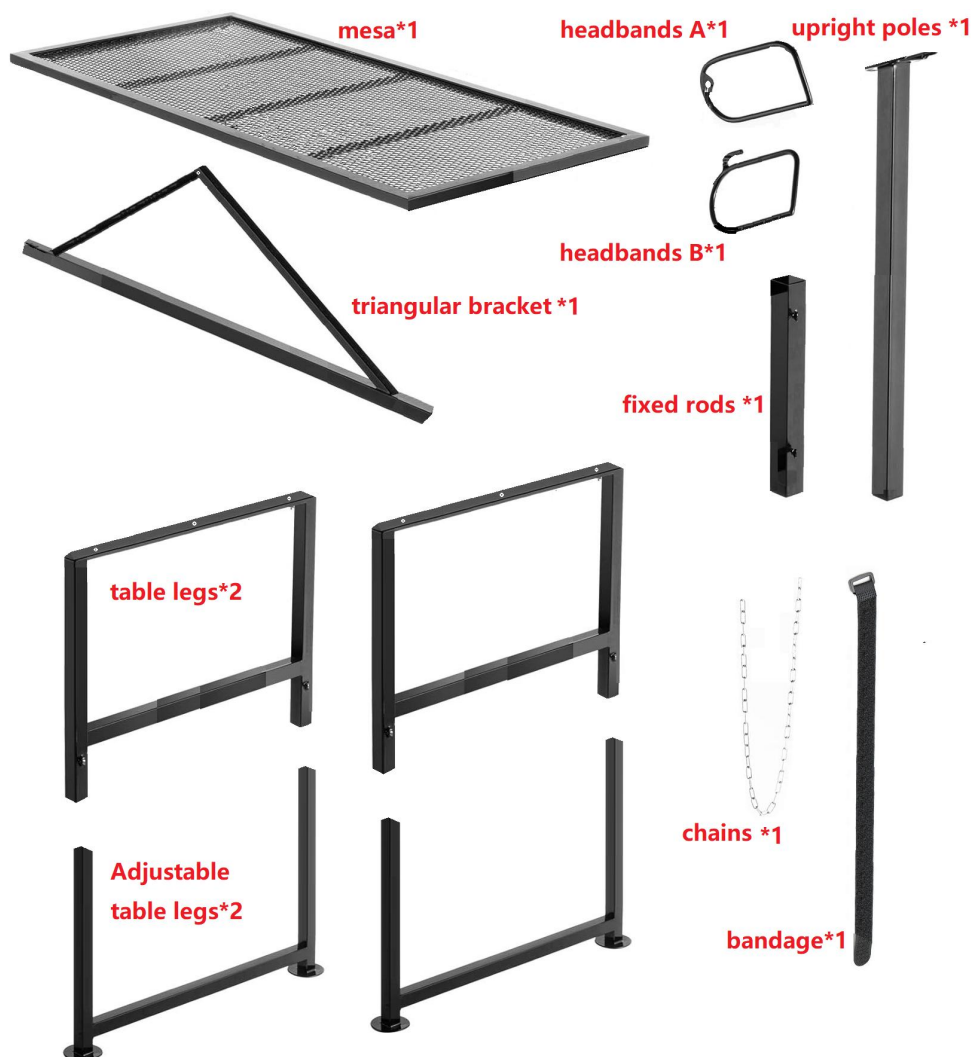





Produktbeskrivning

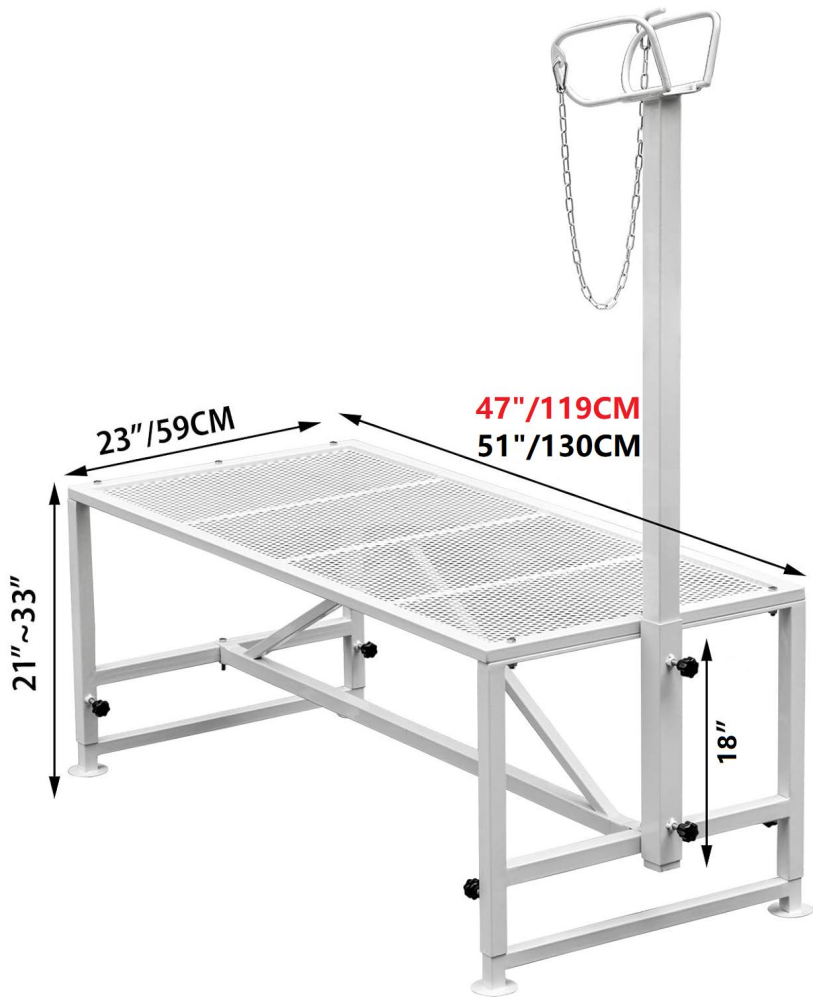

Modell	Färg	Bordsstorlek	Justerbar höjd på bänkskivan	Den upprättstående stången justerar höjden	viktkapacitet
SCJ002-W	vit	47*23 tum	I 21in/533mm;	18 tum/457 mm	500 pund
SCJ003-W	vit	51*23 tum	II 25in/635mm;		
SCJ002-B	svart	47*23 tum	III 29in/736mm;		
SCJ003-B	svart	51*23 tum	IV 33in/838mm;		

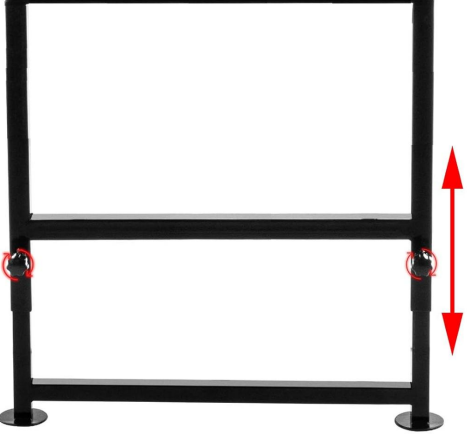

Installationssteg

Delar _	Förklarande diagram	Förklara _
---------	---------------------	------------

<p>bordsben *2</p> <p>justerbara bordsben *2</p> <p>plastknoppar *2</p>		<p>11. Sätt in det justerbara bordsbenet i bordsbenet.</p> <p>12. Fäst bordsbenet med en plastknopp.</p>
<p>M8x35 *5</p> <p>packning *5</p> <p>M8 *5</p>		<p>11. Stöd bänkskivan med monterade bordsben.</p> <p>12. Trä 5 M8x35 hål genom bordsskivan, fäst små distanser och fäst dem med muttrar.</p>

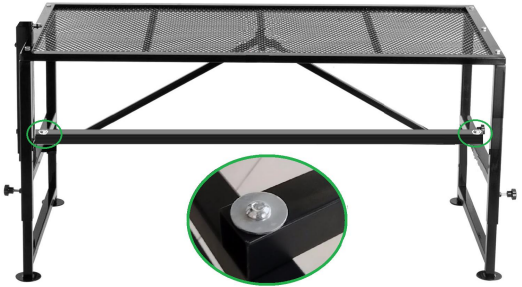
<p>fasta stavar *1</p> <p>M8x35 *1</p> <p>packning *1</p> <p>M8 *1</p>		<p>11. Kläm fast bänkskivan med fasta stavar och rikta in hålen.</p> <p>12. Trä 1 M8x35 genom hålet på de fasta stängerna, fäst den lilla distansen och fäst den med en mutter.</p>
<p>triangulärt fäste *1</p> <p>M8x35 *1</p> <p>packning *1</p> <p>M8 *1</p>		<p>Trä 1 M8x35-skruv genom det mittersta hålet på triangelfästet och fäst med distanser och muttrar.</p>
<p>M8x70 *2</p> <p>stor packning *2</p> <p>M8 *2</p> <p>packning *2</p>		<p>Trä 2 M8x70 skruvar genom den stora distansen, sedan genom hålen på båda sidor av triangelfästet och fäst med distansen och muttern.</p>

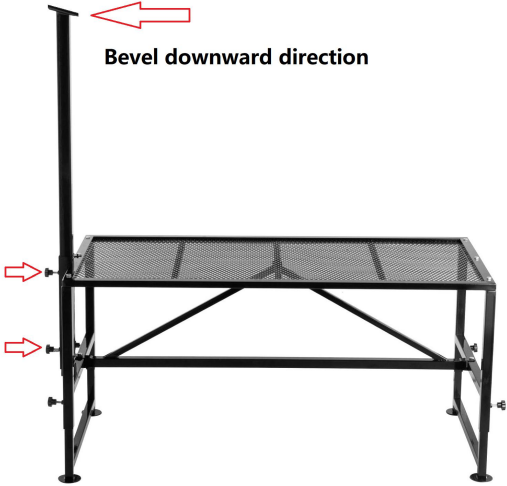
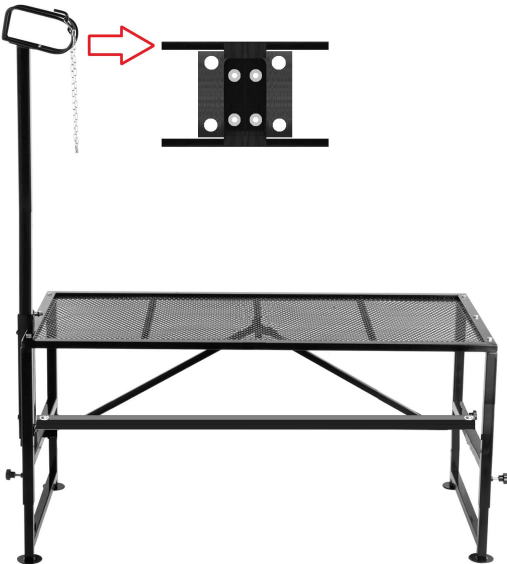
<p>upprättstående stolpar *1</p> <p>plastknoppar *2</p>		<p>11. Sätt in de upprättstående stängerna i det fyrkantiga hålet för fasta stängerna i riktningen nedåt mot avfasningen.</p> <p>12. Fäst de upprättstående stolparna med 2 plastknoppar.</p>
<p>pannband A *1</p> <p>pannband B *1</p> <p>M6x20 *4</p> <p>M6 *4</p>		<p>21. Sätt pannbanden B först.</p> <p>22. Sätt sedan på pannbanden A.</p> <p>23. Fäst pannbanden med 4 M6x20 skruvar.</p> <p>24. Dra åt låsskruvarna med 4 M6 muttrar.</p>

Produktanvändning

Höjden på bordet som motsvarar hålet med fyra bultar växlar.

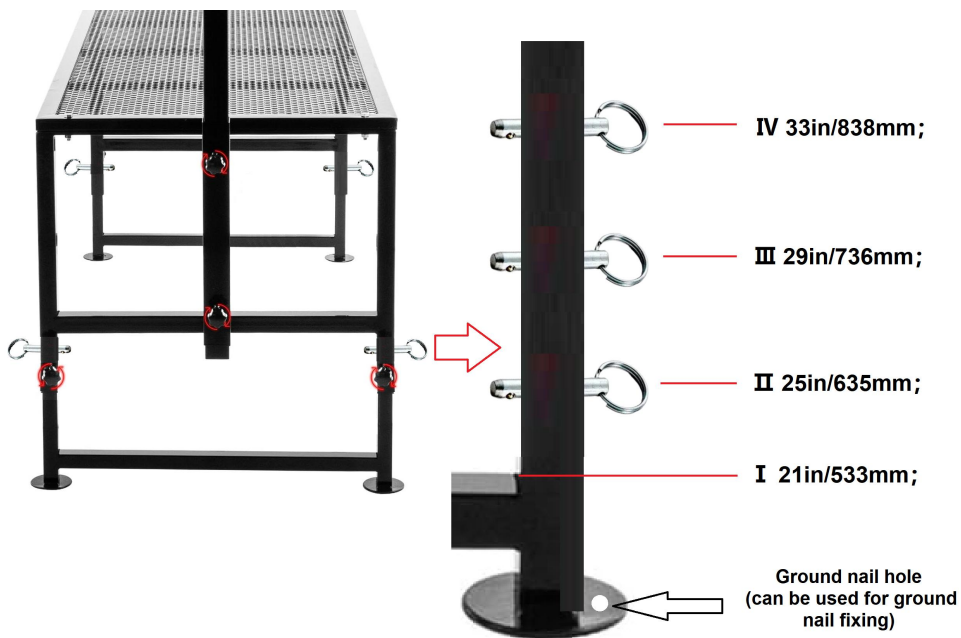

Tillverkare: Shanghaimuxinmuyeyouxiangongsi

Adress: Baoshanqu Shuangchenglu 803long 11hao 1602A-1609shi
Shanghai

Importerad till AUS: SIHAO PTY LTD, 1 ROKEVA STREETEASTWOOD
NSW 2122 Australien

Importerad till USA: Sanven Technology Ltd., Suite 250, 9166 Anaheim
Place, Rancho Cucamonga, CA 91730



SHUNSHUN GmbH
Römeräcker 9 Z2021,76351
Linkenheim-Hochstetten, Germany
euvertreter@gmail.com
+49 1727041930



Pooledas Group Ltd
Unit 5 Albert Edward House, The
Pavilions Preston, United Kingdom
pooledas123@gmail.com
Tel: 01772418127

Tillverkad i Kina

VEVOR[®]

TOUGH TOOLS, HALF PRICE

Teknisk Support och e-garanticertifikat

www.vevor.com/support

VEVOR®

TOUGH TOOLS, HALF PRICE

Técnico Soporte y certificado de garantía electrónica www.vevor.com/support

PUESTO DE RECORTE DE GANADO

MANUAL DE USUARIO

We continue to be committed to provide you tools with competitive price.

"Save Half", "Half Price" or any other similar expressions used by us only represents an estimate of savings you might benefit from buying certain tools with us compared to the major top brands and does not necessarily mean to cover all categories of tools offered by us. You are kindly reminded to verify carefully when you are placing an order with us if you are actually saving half in comparison with the top major brands.

VEVOR®

TOUGH TOOLS, HALF PRICE

LIVESTOCK TRIMMING STAND

SCJ002-W /SCJ003-W /SCJ002-B /SCJ003-B



NEED HELP? CONTACT US!

Have product questions? Need technical support? Please feel free to contact us:

Technical Support and E-Warranty Certificate
www.vevor.com/support

This is the original instruction, please read all manual instructions carefully before operating. VEVOR reserves a clear interpretation of our user manual. The appearance of the product shall be subject to the product you received. Please forgive us that we won't inform you again if there are any technology or software updates on our product.

Precauciones de seguridad

ADVERTENCIA:

Lea estas instrucciones antes de usar este producto. De lo contrario, se pueden producir lesiones graves. Siempre se deben seguir las precauciones básicas , incluidas las siguientes:

31. El puesto de recorte de ganado No se puede utilizar ni almacenar en zonas peligrosas. No está permitido utilizar el aparato en lugares peligrosos.
32. El puesto de recorte de ganado Se debe verificar para garantizar que esté en buenas condiciones de funcionamiento y que funcione de manera segura antes de su uso. De lo contrario , no se debe utilizar el aparato.
33. Úselo únicamente según lo previsto. El puesto de recorte de ganado debe colocarse en un terreno nivelado para su uso. Si es necesario, los cuatro pies se pueden asegurar con clavos rectificadas.
34. El operador debe utilizar el puesto de recorte de ganado. adecuadamente. Debe tener en cuenta las condiciones locales y prestar atención a terceros , en particular a los niños , cuando trabaje con el puesto de pastoreo .
35. Este puesto de recorte de ganado no está destinado a ser utilizado por personas (incluidos niños) con capacidades físicas , sensoriales o mentales reducidas o que carezcan de experiencia y/o conocimientos , a menos que estén supervisados por una persona responsable de su seguridad o sean instruidos por estas personas sobre el uso de el dispositivo. Se debe supervisar a los niños para asegurarse de que no jueguen con el puesto de recorte de ganado .

GUARDA ESTAS INSTRUCCIONES

Lista de productos

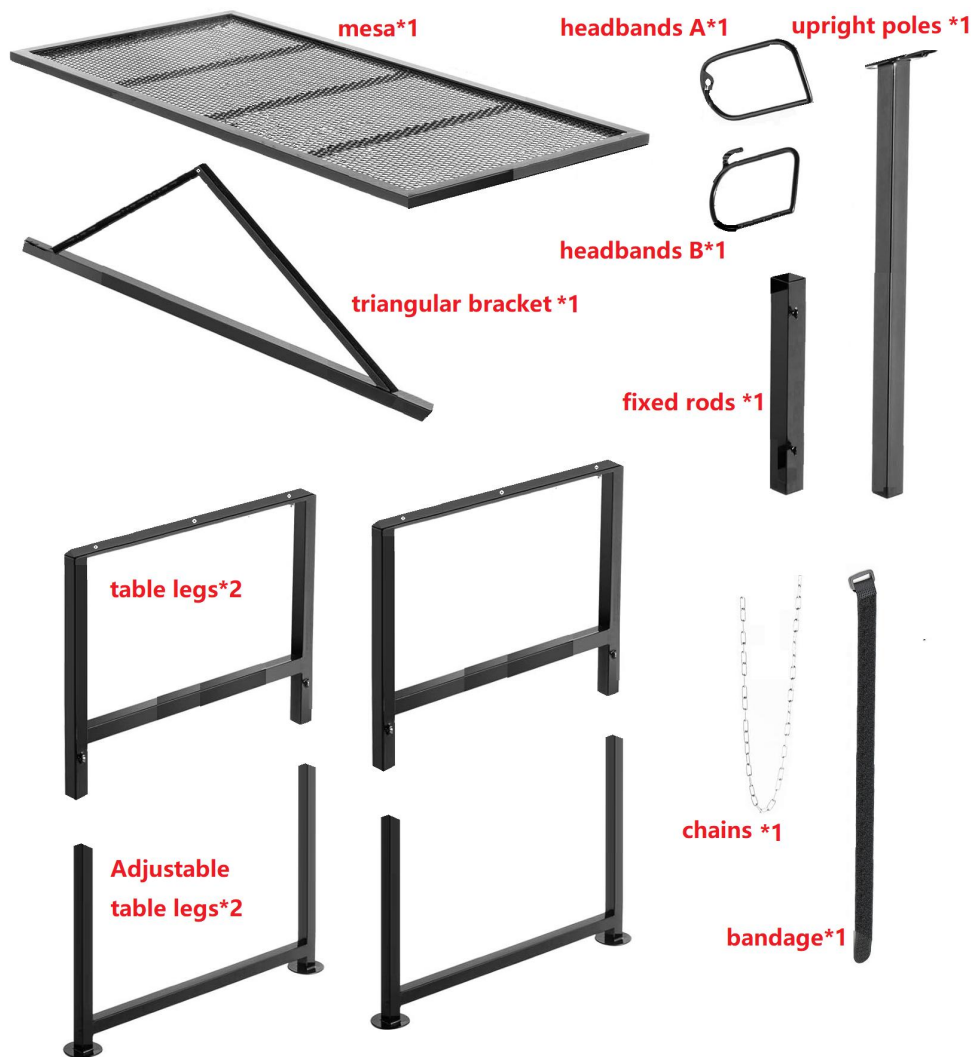



Plastic knobs *6



M8x70 *2



Big gasket *2

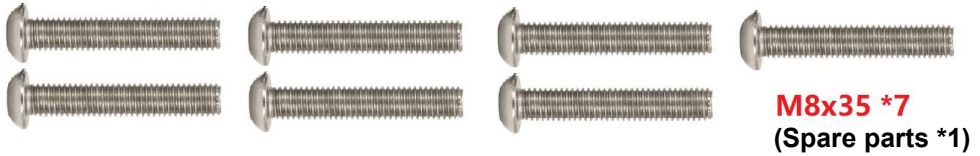

**M8x35 *7
(Spare parts *1)**



**M8 *7
(Spare parts *1)**



**gasket *9
(Spare parts *1)**



M6x20 *4



M6 *4



Bolt *4

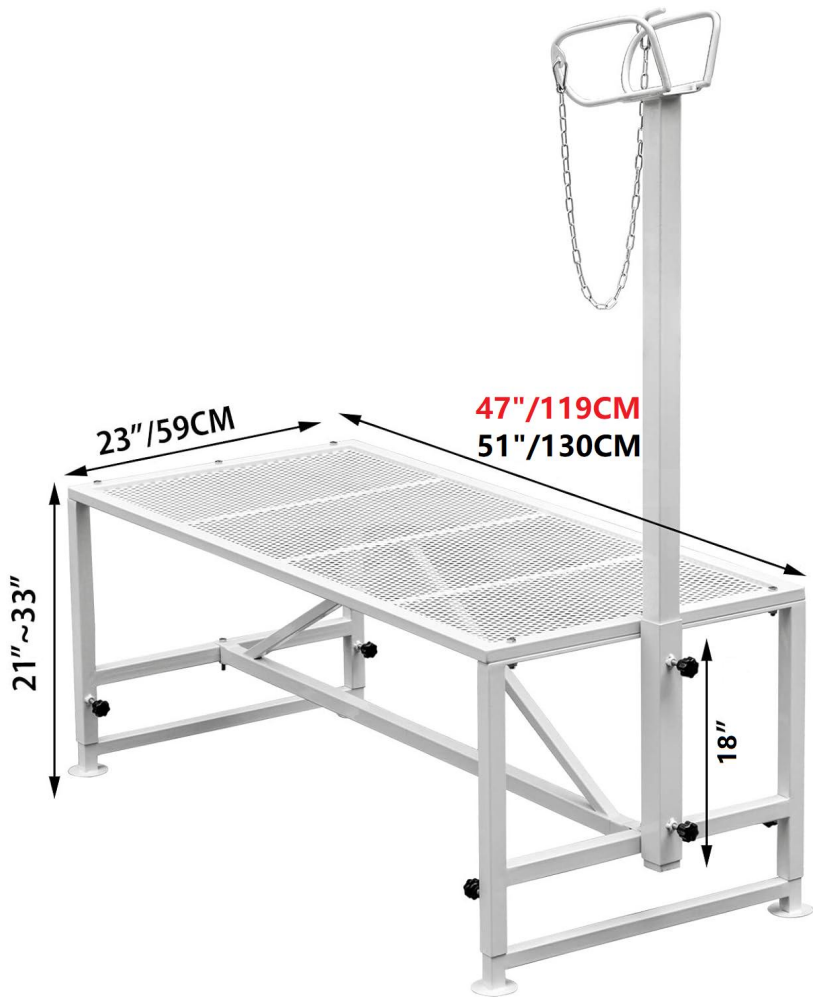

Descripción del Producto

Modelo	Color	Tamaño de la mesa	Altura ajustable de la encimera.	La varilla vertical ajusta la altura.	capacidad de peso
SCJ002-W	blanco	47*23 pulgadas	I 21 pulgadas/533 mm; II 25 pulgadas/635 mm; III 29 pulgadas/736 mm; IV 33 pulgadas/838 mm;	18 pulg./457 mm	500 libras
SCJ003-W	blanco	51*23 pulgadas			
SCJ002-B	negro	47*23 pulgadas			
SCJ003-B	negro	51*23 pulgadas			

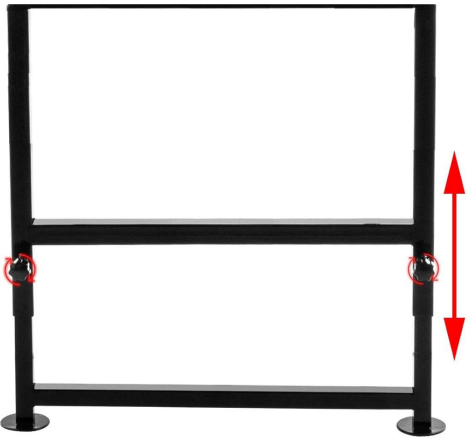

Pasos de instalación

Partes _	Cuadro explicativo	Explicar _
----------	--------------------	------------

<p>patas de mesa *2</p> <p>patas de mesa ajustables * 2</p> <p>perillas de plástico * 2</p>		<p>13. Inserte la pata de la mesa ajustable en la pata de la mesa.</p> <p>14. Asegure la pata de la mesa con una perilla de plástico.</p>
<p>M8x35 *5</p> <p>junta *5</p> <p>M8 *5</p>		<p>13. Apoye la encimera con las patas de la mesa ensambladas.</p> <p>14. Pase 5 orificios M8x35 a través de la superficie de la mesa, coloque pequeños espaciadores y asegúrelos con tuercas.</p>

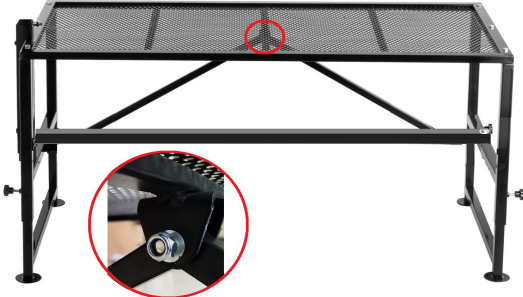
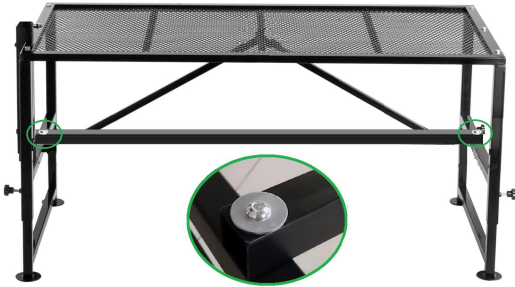
<p>varillas fijas *1</p> <p>M8x35 *1</p> <p>junta * 1</p> <p>M8 *1</p>		<p>13. Bloquee la encimera con varillas fijas y alinee los agujeros.</p> <p>14. Pase 1 M8x35 por el orificio de las varillas fijas, coloque el espaciador pequeño y asegúrelo con una tuerca.</p>
<p>soporte triangular * 1</p> <p>M8x35 *1</p> <p>junta * 1</p> <p>M8 *1</p>		<p>Pase 1 tornillo M8x35 a través del orificio central del soporte triangular y asegúrelo con espaciadores y tuercas.</p>
<p>M8x70 *2</p> <p>junta grande * 2</p> <p>M8 *2</p> <p>junta *2</p>		<p>Pase 2 tornillos M8x70 a través del espaciador grande, luego a través de los orificios en ambos lados del soporte triangular y asegúrelos con el espaciador y la tuerca.</p>

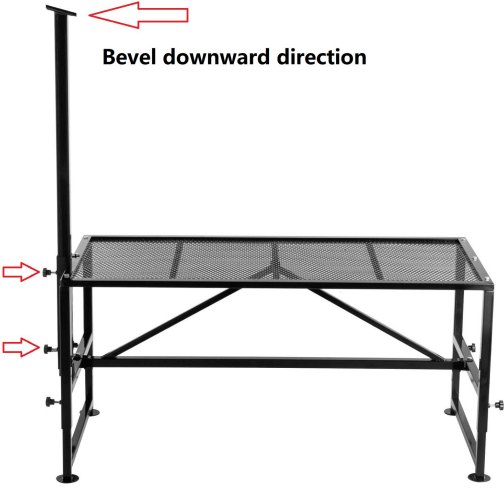
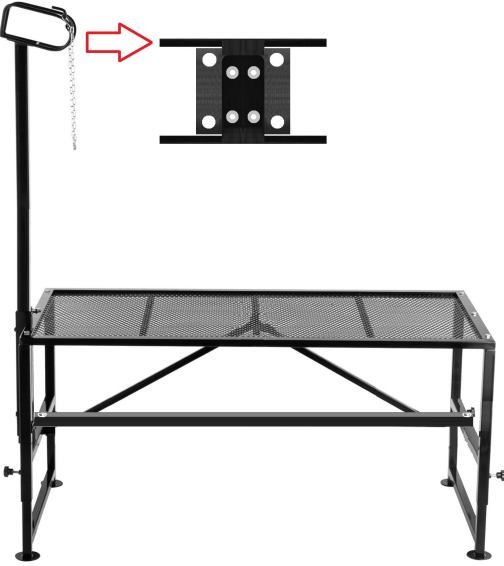
<p>postes verticales * 1</p> <p>perillas de plástico * 2</p>		<p>13. Inserte los postes verticales en el orificio cuadrado de las varillas fijas en la dirección hacia abajo del bisel.</p> <p>14. Asegure los postes verticales con 2 perillas de plástico.</p>
<p>diademas A * 1</p> <p>diademas B * 1</p> <p>M6x20 *4</p> <p>M6 *4</p>		<p>25. Pon las cintas para la cabeza B primero.</p> <p>26. Luego pon las diademas A.</p> <p>27. Fijar las diademas con 4 tornillos M6x20.</p> <p>28. Apriete los tornillos de bloqueo con 4 tuercas M6.</p>

Uso del producto

La altura de la mesa correspondiente al orificio de los cuatro pernos engranajes.

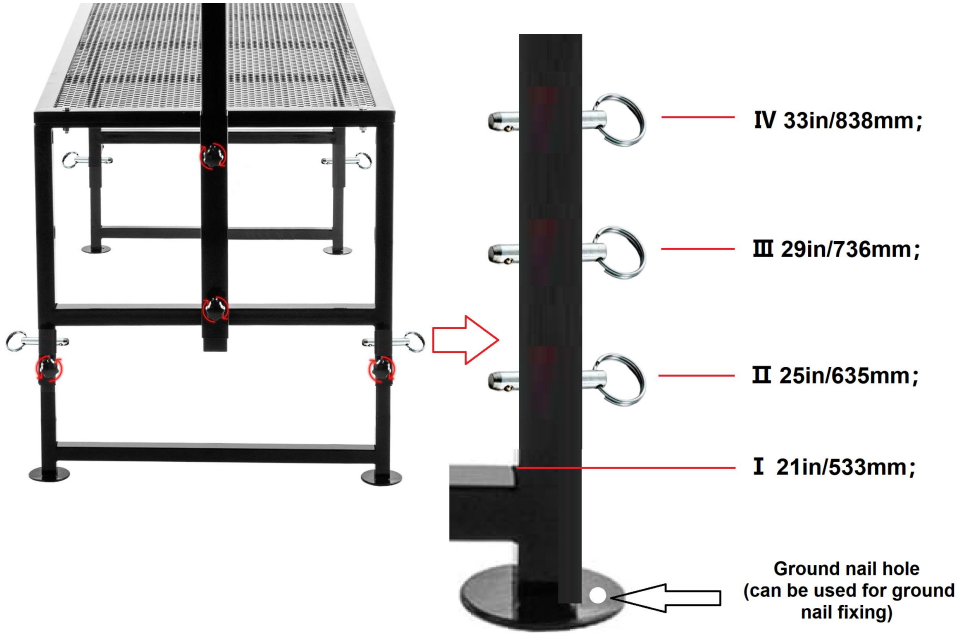



Fabricante: Shanghai muxinmuyeyouxiangongsi

Dirección: Baoshanqu Shuangchenglu 803long 11hao 1602A-1609shi
Shanghai

Importado a AUS: SIHAO PTY LTD, 1 ROKEVA STREET EASTWOOD
NSW 2122 Australia

Importado a EE. UU.: Sanven Technology Ltd., Suite 250, 9166 Anaheim
Place, Rancho Cucamonga, CA 91730



SHUNSHUN GmbH
Römeräcker 9 Z2021,76351
Linkenheim-Hochstetten, Germany
euvertreter@gmail.com
+49 1727041930



Pooledas Group Ltd
Unit 5 Albert Edward House, The
Pavilions Preston, United Kingdom
pooledas123@gmail.com
Tel: 01772418127

Hecho en china

VEVOR®

TOUGH TOOLS, HALF PRICE

Técnico Certificado de soporte y garantía electrónica

www.vevor.com/support

VEVOR[®]

TOUGH TOOLS, HALF PRICE

Tecnico Supporto e certificato di garanzia elettronica www.vevor.com/support

SUPPORTO PER LA RIFINITURA DEL BESTIAME MANUALE D'USO

We continue to be committed to provide you tools with competitive price.

"Save Half", "Half Price" or any other similar expressions used by us only represents an estimate of savings you might benefit from buying certain tools with us compared to the major top brands and does not necessarily mean to cover all categories of tools offered by us. You are kindly reminded to verify carefully when you are placing an order with us if you are actually saving half in comparison with the top major brands.

VEVOR[®]

TOUGH TOOLS, HALF PRICE

LIVESTOCK TRIMMING STAND

SCJ002-W /SCJ003-W /SCJ002-B /SCJ003-B



NEED HELP? CONTACT US!

Have product questions? Need technical support? Please feel free to contact us:

Technical Support and E-Warranty Certificate
www.vevor.com/support

This is the original instruction, please read all manual instructions carefully before operating. VEVOR reserves a clear interpretation of our user manual. The appearance of the product shall be subject to the product you received. Please forgive us that we won't inform you again if there are any technology or software updates on our product.

Misure di sicurezza

AVVERTIMENTO:

Leggere queste istruzioni prima di utilizzare questo prodotto. In caso contrario si potrebbero causare lesioni gravi. È necessario seguire sempre le precauzioni di base , incluse le seguenti:

36. Il banco di rifinitura del bestiame non può essere utilizzato o conservato in aree pericolose. Non è consentito utilizzare l'apparecchio in luoghi pericolosi.

37. Il banco di rifinitura del bestiame deve essere controllato per garantire che sia in buone condizioni di funzionamento e funzioni in sicurezza prima dell'uso. In caso contrario l'apparecchio non deve essere utilizzato.

38. Utilizzare solo come previsto. Per l'uso, il supporto per la rifinitura del bestiame deve essere posizionato su un terreno pianeggiante. Se necessario, i quattro piedi possono essere fissati con chiodi a terra.

39. L'operatore deve utilizzare il supporto di rifinitura del bestiame correttamente. Durante il lavoro con il banco di tosatura deve tenere conto delle condizioni locali e prestare attenzione a terzi , in particolare ai bambini .

40. Questo supporto per la rifinitura del bestiame non è destinato all'uso da parte di persone (compresi i bambini) con ridotte capacità fisiche , sensoriali o mentali o prive di esperienza e/o conoscenza , a meno che non siano supervisionate da una persona responsabile della loro sicurezza o siano istruite da queste persone sull'uso di il dispositivo. I bambini devono essere sorvegliati per assicurarsi che non giochino con il banco di rifinitura del bestiame .

CONSERVA QUESTE ISTRUZIONI

Elenco prodotti

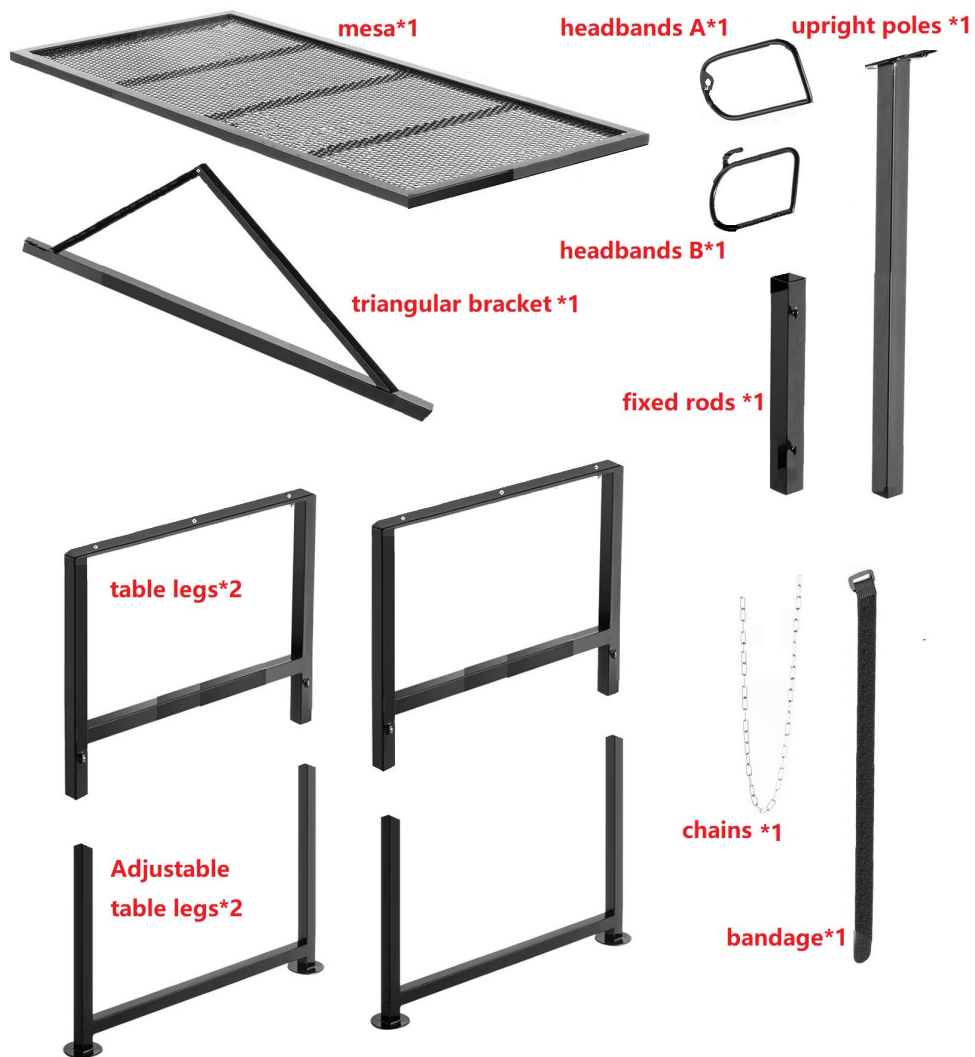

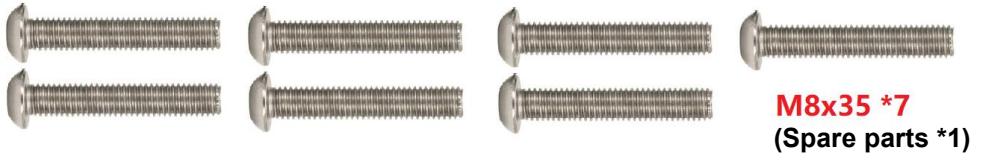

Descrizione del prodotto

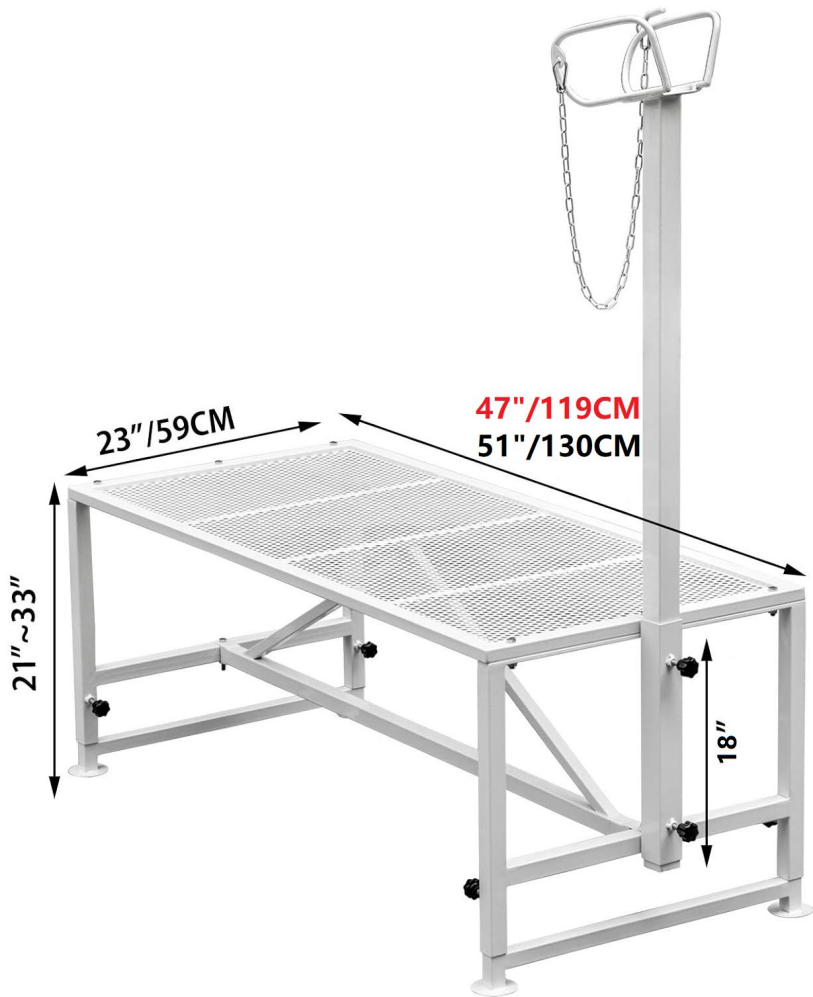

Modello	Colore	Dimensioni della tavola	Altezza del piano di lavoro regolabile	L'asta verticale regola l'altezza	capacità di peso
SCJ002-W	bianco	47*23 pollici	I 21 pollici/533 mm;	18 pollici/457 mm	500 libbre
SCJ003-W	bianco	51*23 pollici	II 25 pollici/635 mm;		
SCJ002-B	nero	47*23 pollici	III 29 pollici/736 mm;		
SCJ003-B	nero	51*23 pollici	IV 33 pollici/838 mm;		

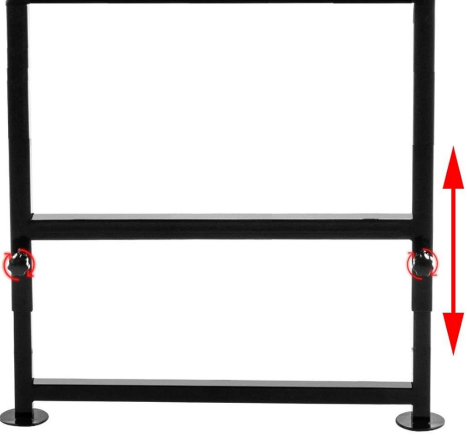
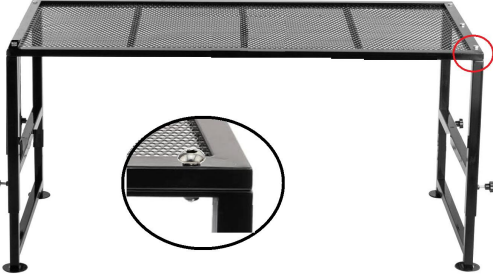

Passaggi di installazione

Parti _	Grafico esplicativo	Spiegare _
---------	---------------------	------------

<p>gambe del tavolo *2</p> <p>gambe del tavolo regolabili *2</p> <p>manopole in plastica *2</p>		<p>15. Inserire la gamba del tavolo regolabile nella gamba del tavolo.</p> <p>16. Fissare la gamba del tavolo con una manopola di plastica.</p>
<p>M8x35*5</p> <p>guarnizione *5</p> <p>M8*5</p>		<p>15. Sostenere il piano di lavoro con le gambe del tavolo assemblate.</p> <p>16. Infila 5 fori M8x35 attraverso il piano del tavolo, attacca piccoli distanziatori e fissali con i dadi.</p>

<p>aste fisse *1</p> <p>M8x35*1</p> <p>guarnizione *1</p> <p>M8*1</p>		<p>15. Blocca il piano di lavoro con aste fisse e allinea i fori.</p> <p>16. Infilare 1 M8x35 attraverso il foro delle aste fisse, collegare il piccolo distanziatore e fissarlo con un dado.</p>
<p>staffa triangolare *1</p> <p>M8x35*1</p> <p>guarnizione *1</p> <p>M8*1</p>		<p>Avvitare 1 vite M8x35 attraverso il foro centrale della staffa triangolare e fissarla con distanziatori e dadi.</p>

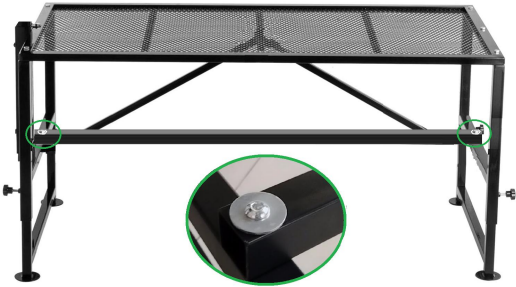
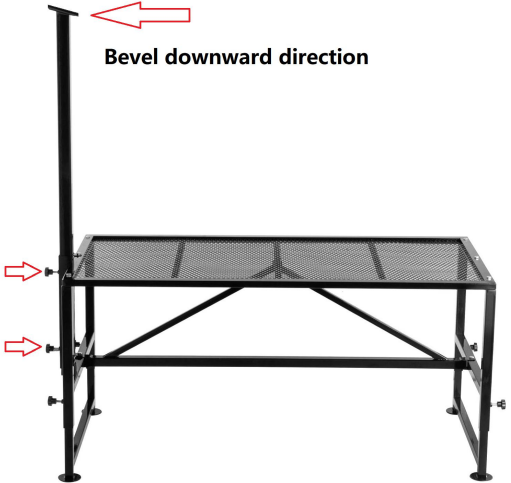
<p>M8x70*2</p> <p>guarnizione grande *2</p> <p>M8*2</p> <p>guarnizione *2</p>		<p>Avvita 2 viti M8x70 attraverso il distanziale grande, quindi attraverso i fori su entrambi i lati della staffa triangolare e fissale con il distanziale e il dado.</p>
<p>pali verticali *1</p> <p>manopole in plastica *2</p>		<p>15. Inserire i pali verticali nel foro quadrato dell'asta fissa nella direzione verso il basso della smussatura.</p> <p>16. Fissare i pali verticali con 2 pomelli in plastica.</p>

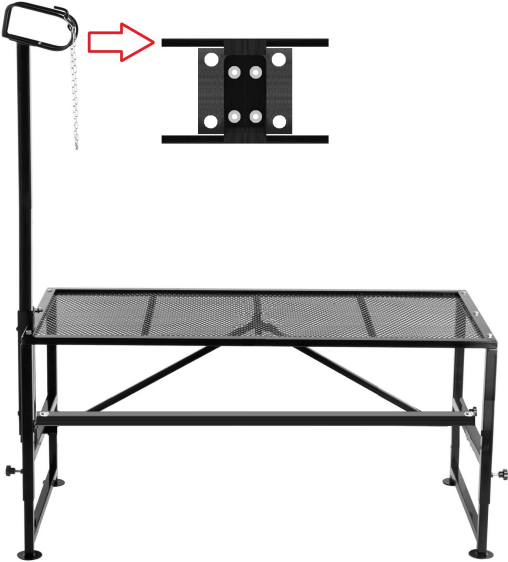
<p>fasce per capelli A *1</p> <p>fasce B *1</p> <p>M6x20*4</p> <p>M6*4</p>		<p>29. Metti prima le fasce B.</p> <p>30. Poi metti le fasce A.</p> <p>31. Fissare le fasce con 4 viti M6x20.</p> <p>32. Stringere le viti di bloccaggio con 4 dadi M6.</p>
----------------------------------------------------------------------------	-----------------------------------------------------------------------------------	-----------------------------------------------------------------------------------------------------------------------------------------------------------------------------

Utilizzo del prodotto

L'altezza del tavolo corrisponde ai quattro fori per i bulloni ingranaggi.

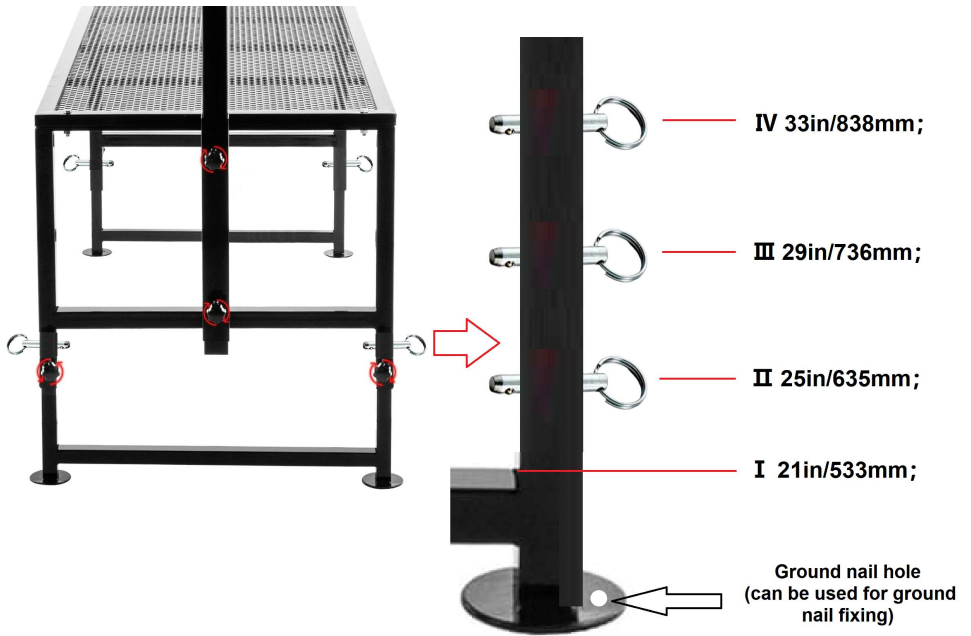

Produttore: Shanghai muxinmuyeyouxiangongsi

Indirizzo: Baoshanqu Shuangchenglu 803long 11hao 1602A-1609shi
Shanghai

Importato in AUS: SIHAO PTY LTD, 1 ROKEVA STREETEASTWOOD
NSW 2122 Australia

Importato negli Stati Uniti: Sanven Technology Ltd., Suite 250, 9166
Anaheim Place, Rancho Cucamonga, CA 91730



SHUNSHUN GmbH
Römeräcker 9 Z2021,76351
Linkenheim-Hochstetten, Germany
euvertreter@gmail.com
+49 1727041930



Pooledas Group Ltd
Unit 5 Albert Edward House, The
Pavilions Preston, United Kingdom
pooledas123@gmail.com
Tel: 01772418127

Made in China

VEVOR[®]

TOUGH TOOLS, HALF PRICE

Tecnico Supporto e certificato di garanzia elettronica

www.vevor.com/support