

# Table-Mounted Pot Rack

## ASSEMBLY INSTRUCTIONS

**MODELS UP TO 96" LONG**  
**(FOR MODELS 108" AND LONGER, GO TO PAGE 3)**

### CAUTION

INSPECT CONTENTS IMMEDIATELY AND FILE CLAIM WITH DELIVERING CARRIER FOR ANY DAMAGE.

**SAVE YOUR BOX AND ALL PACKING MATERIALS.**

YOU ARE RESPONSIBLE FOR DAMAGE TO YOUR UNIT IF RETURNED IMPROPERLY PACKED.

### Parts List

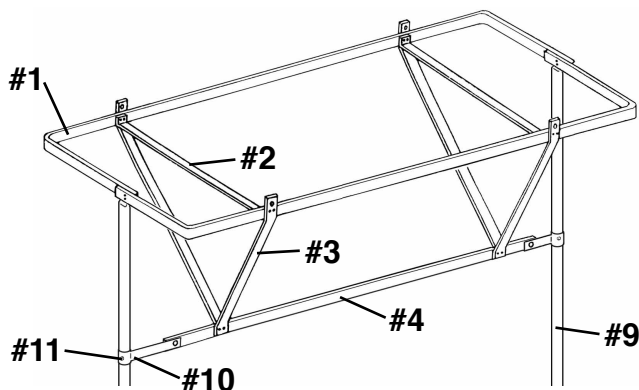

#	qty	part #	description
#1	2	*	bar - top piece
#2	*	305669	cross top support
#3	*	305668	support
#4	1	*	bottom rack bar
#5	*	306136	hex head bolt $\frac{3}{8}$ "-1"
#6	*	306122	lock washer, $\frac{3}{8}$ "
#7	*	306137	cap nut, $\frac{3}{8}$ "
#8	4	306138	hex cap bolt, $\frac{3}{8}$ "- $\frac{3}{4}$ "
#9	2	305663	84" leg
#10	2	306569	leg clip
#11	*	326785	bolt gusset, $\frac{3}{8}$ "-16 x 2 $\frac{1}{4}$ "
#12	*	310176	nut, $\frac{3}{8}$ "-16
#13	2	300962**	bolt, $\frac{1}{2}$ "-13 x 1 $\frac{1}{2}$ "
		or	
#14	2	304143***	bolt, $\frac{1}{2}$ "-13 x 2 $\frac{1}{2}$ "

actual size of hardware:

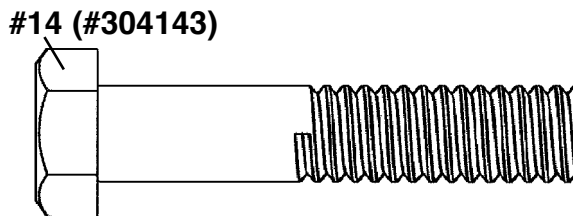
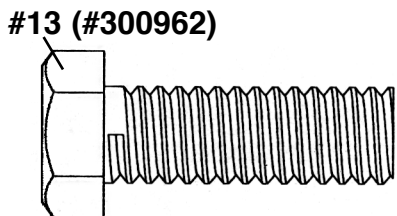
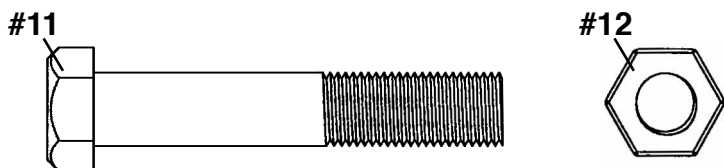
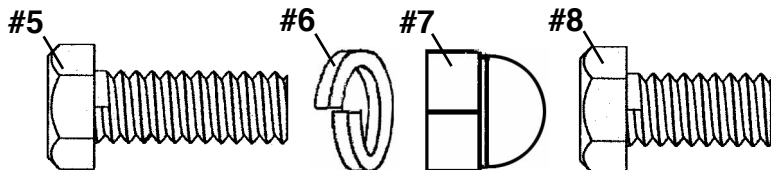

\* Quantities and/or part numbers vary, depending on size.

\*\* Used with tables that do not have center channels on undershelf.

\*\*\* Used with tables that have center channels on undershelf.

(continued on next page)

EG9842 Revised 10/22

# Table-Mounted Pot Rack

## ASSEMBLY INSTRUCTIONS

### MODELS UP TO 96" LONG

#### Step 1 - Bolt leg to each end of table.

Please note:

- If you are assembling table-mounted pot rack to a pre-existing table, you are required to drill appropriate holes. Tabletop hole is 1-5/8" diameter. Undershef hole is 1/2" diameter.
- If you ordered an optional adjustable shelf for table-mounted pot rack, attach to tubular supports now at desired height.

*Please note before continuing:  
For easier assembly, turn table onto its side.*

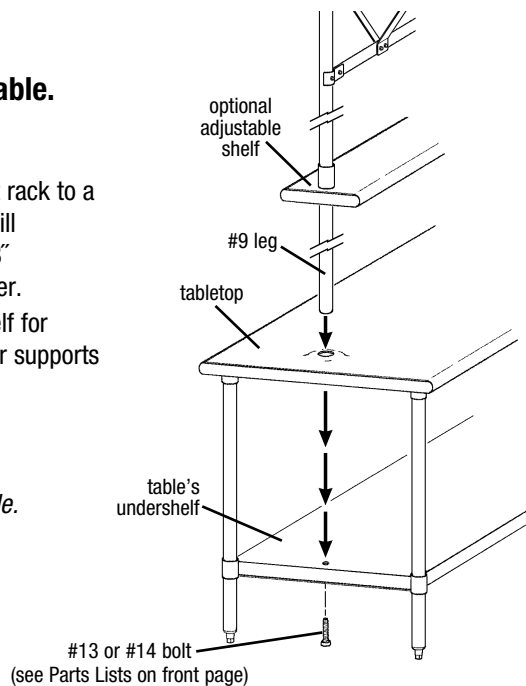

#### Step 2 - Assemble top bar.

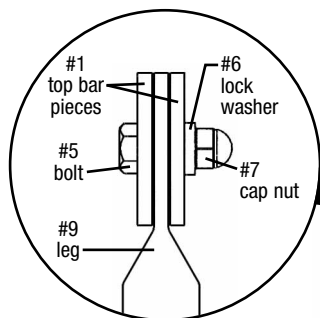

#### Step 3 - Attach cross top supports and bottom supports to top bar assembly.

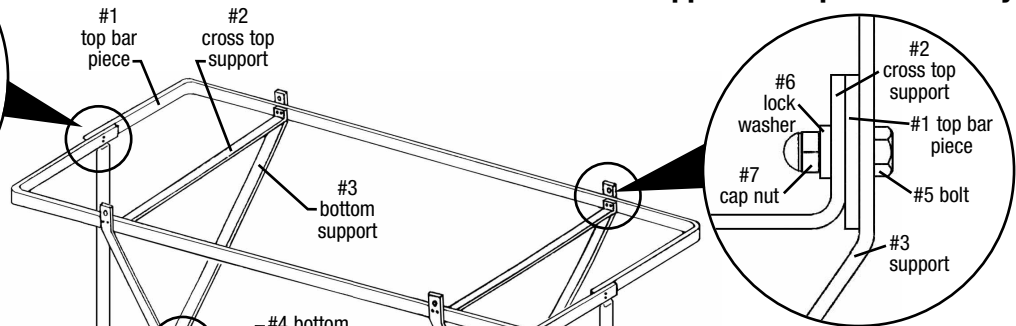

#### Step 4 - Attach bottom rack bar.

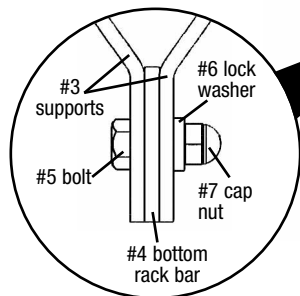

#### Step 5 - Attach leg clips to bottom rack bar.

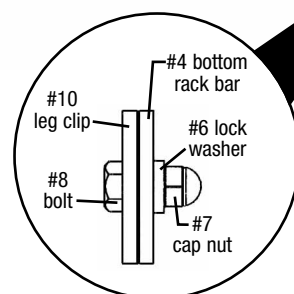

#### Step 6 - Attach leg clips to legs.

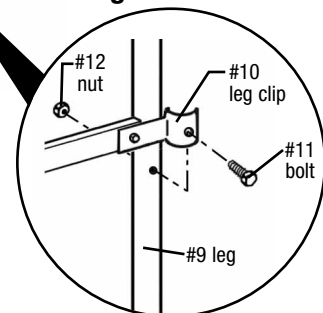

Tighten all hardware.

**(End)**

# Table-Mounted Pot Rack

## ASSEMBLY INSTRUCTIONS

### MODELS 108" AND LONGER

(FOR MODELS UP TO 96" LONG, GO TO FRONT PAGE)

### Parts List

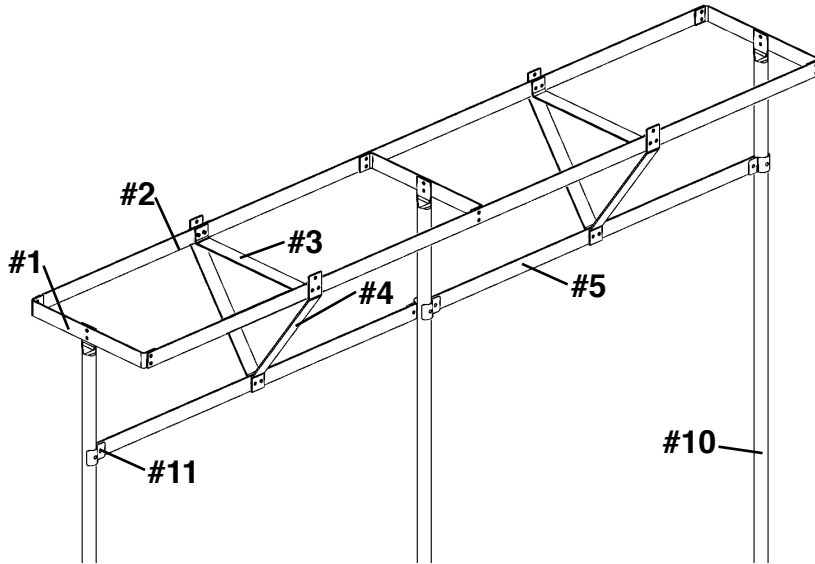

#	qty	part #	description
#1	3	317135	leg support bar
#2	2	*	bar - top piece
#3	2	305669	cross top support
#4	4	305668	support
#5	2	*	bar - bottom piece
#6	30	306136	hex head bolt $\frac{3}{8}$ "-1"
#7	34	306122	lock washer, $\frac{3}{8}$ "
#8	34	306137	cap nut, $\frac{3}{8}$ "
#9	4	306138	hex cap bolt, $\frac{3}{8}$ "- $\frac{3}{4}$ "
#10	3	305663	84" leg
#11	4	306569	leg clip
#12	3	326785	bolt gusset, $\frac{3}{8}$ "-16 x 2 $\frac{1}{4}$ "
#13	3	310176	nut, $\frac{3}{8}$ "-16
#14	3	300962**	bolt, $\frac{1}{2}$ "-13 x 1 $\frac{1}{2}$ "
		or	
#15	3	304143***	bolt, $\frac{1}{2}$ "-13 x 2 $\frac{1}{2}$ "

\* Part numbers vary, depending on size.

\*\* Used with tables that do not have center channels on undershelf.

\*\*\* Used with tables that have center channels on undershelf.

actual size of hardware:

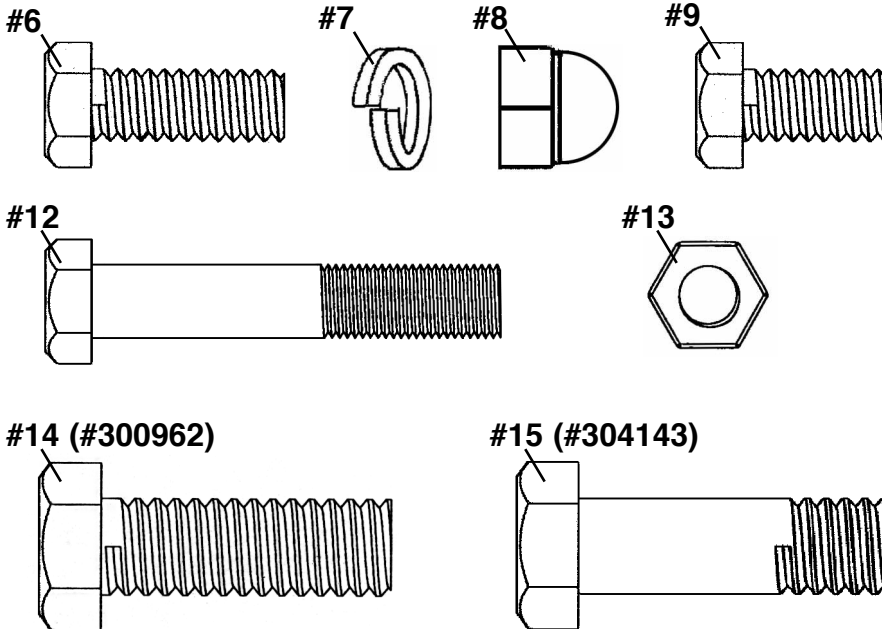

(continued on back page)

# Table-Mounted Pot Rack

## ASSEMBLY INSTRUCTIONS

### MODELS 108" AND LONGER

(FOR MODELS UP TO 96" LONG, GO TO FRONT PAGE)

#### Step 1 - Bolt legs to table's undershelf.

- If you are assembling table-mounted pot rack to a pre-existing table, you are required to drill appropriate holes. Tabletop hole is 1-5/8" diameter. Undershelf hole is 1/2" diameter.
- Racks 108" and longer have three legs. You will need to drill a hole for each end leg, plus one for the center leg.
- If you ordered an optional adjustable shelf for table-mounted pot rack, attach to tubular supports now at desired height.

*Please note before continuing:*

*For easier assembly, turn table onto its side.*

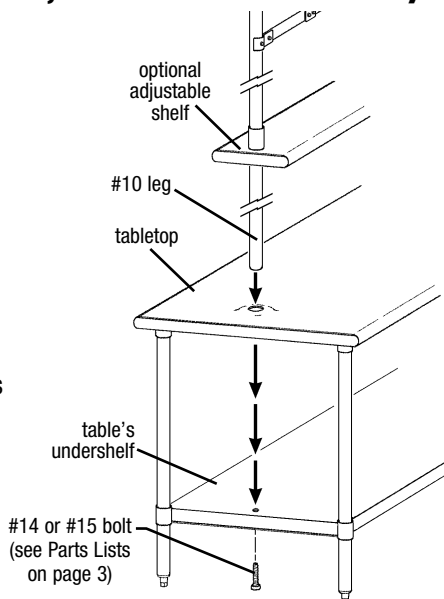

#### Step 2 - Affix leg support bars to legs.

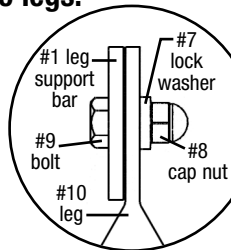

#### Step 3 - Attach top bar pieces to leg support bars.

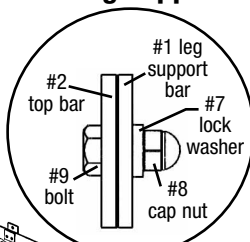

#### Step 4 - Attach cross top supports and bottom supports to top bar assembly.

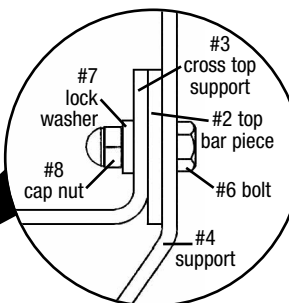

#### Step 5 - Attach bottom rack bar.

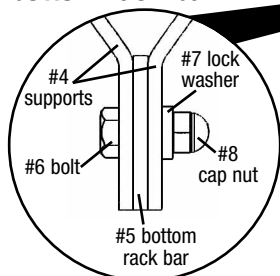

#### Step 6 - Attach leg clips to bottom rack bar pieces and center leg.

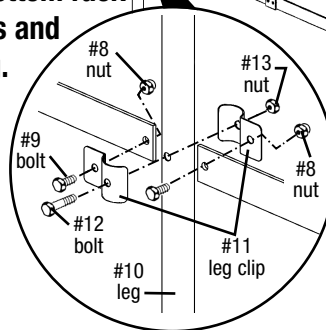

#### Step 7 - Attach leg clips to bottom rack bar pieces and end legs.

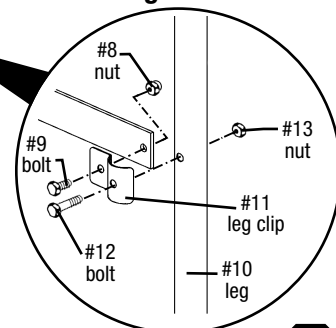

Tighten all hardware.

**(End)**



Profit from the Eagle Advantage®

- 100 Industrial Boulevard, Clayton, Delaware 19938-8903 U.S.A.
- Phone: 302/653-3000 • 800/441-8440 • Fax: 302/653-2065
- www.eaglegrp.com • www.eaglegrpnews.com • www.eaglemhc.com

Eagle Foodservice Equipment, Eagle MHC, and SpecFAB® are divisions of Eagle Group. ©2022 by the Eagle Group