

FRIGIDAIRE

All about the

Use & Care

of your

Packaged Terminal Air Conditioner



TABLE OF CONTENTS

SAFETY CONSIDERATIONS	2	AUXILIARY CONTROLS.....	13-14
GENERAL INFORMATION	2	CARE AND CLEANING	15
UNIT FEATURES	3	PREVENTATIVE MAINTENANCE	16
INSTALLATION	4-6	TROUBLESHOOTING	17
ELECTRICAL DATA	7	SAFETY PRECAUTIONS.....	18
SYSTEM CONFIGURATION.....	8-10	MAJOR APPLIANCE LIMITED WARRANTY.....	19
OPERATION	11-12		

SAFETY CONSIDERATIONS

Recognize safety information. This is the safety-alert symbol . When you see this symbol on the unit and in instructions or manuals, be alert to the potential for personal injury.

Understand these signal words: DANGER, WARNING, and CAUTION. These words are used with the safety-alert symbol. DANGER identifies the most serious hazards which will result in severe personal injury or death. WARNING signifies hazards which could result in personal injury or death.

CAUTION is used to identify unsafe practices which may result in minor personal injury or product and property damage. NOTE is used to highlight suggestions which will result in enhanced installation, reliability, or operation.

 WARNING

PERSONAL INJURY AND/OR PROPERTY DAMAGE HAZARD

Failure to follow this warning could result in personal injury, death and/or property damage.

For your safety, the information in this manual must be followed to minimize the risk of fire or explosion, electric shock, or to prevent property damage, personal injury, or loss of life.

- This unit must be properly installed in accordance with the Installation Instructions before it is used.
- Immediately repair or replace all electric service cords that have become frayed or otherwise damaged.
- Unplug or disconnect the unit at the fuse box or circuit breaker before making any repairs.

NOTE: We strongly recommend that any servicing be performed by a qualified professional.

GENERAL INFORMATION

Frigidaire package terminal air conditioners and heat pumps provide a high standard of quality in performance, workmanship, durability and appearance as they heat and cool the occupied air space year round.

This manual provides information for ease of installation, operation and maintenance.

All models are designed for through the wall installation. Separate installation instructions are included with all accessory components.

BEFORE YOU BEGIN

Read these instructions completely and carefully.

IMPORTANT: Save these instructions for local inspector's use.

IMPORTANT: Observe all governing codes and ordinances.

NOTE TO INSTALLER

Be sure to leave these instructions with the owner.

NOTE TO OWNER

Keep these instructions for future reference. Be sure to write down the model and serial number on the space provided on the product registration card. The model and serial number can be located on the serial number plate attached to the unit. These numbers are required for service. (See Fig. 1.)



FRIGIDAIRE PACKAGED TERMINAL AIR CONDITIONER MODEL: ENG: 0 <small>Made in China</small>	ELECTRICAL VOLTS Hz, PH.	COOLING DATA BTU- EER- AMPS- WATTS-	ELECTRIC HEATING BTU- AMPS- WATTS-	DESIGN PRESSURE LOW- PSIG HIGH- PSIG R410A- OZ	VERIFIED  VERIFIÉ <small>Warning Use on Single Outlet Circuit Only</small>			SERIAL No.: IK00700001 DATE: 03/11 FOR SERVICE CALL FRIGIDAIRE 1-866-942-1567
---	--------------------------------	---	---	---	--	---	---	--

Fig. 1 – Sample Data Information Plate



UNIT FEATURES

This unit has many exciting features which are different from those found on standard PTAC models. The owner must be familiar with these features in order to fully understand the operation and capability of the unit.

- **Total Corrosion® Protection** -- All Frigidaire PTAC's come standard with anti-corrosion protection, to increase system and component durability in standard applications and protect system and components in Coastal areas where Air sea salt content is higher than standard applications. All coils are treated with a dual hydrophilic coating, and an added hydrophilic coating for all connecting plates. Standard materials have been replaced with stainless steel for critical components such as hardware, condenser side panel, compressor hardware and Condenser fan hardware. Special anti-corrosion paint is used on the drain pan to ensure the integrity of unit mounts to the chassis.

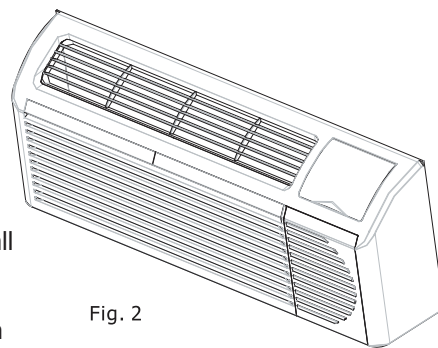

Fig. 2

- **Dry Mode** -- For increased comfort and humidity management, an added "Dry Mode" is standard on all Frigidaire PTAC's. This mode feature will help manage and reduce the humidity content within the living space, making it more comfortable. In DRY mode, the unit will modulate cooling mode at low fan speed until the room temperature is 4° F below the room temperature setting regardless of fan mode selection. Dry mode should not be considered a substitute for a standalone dehumidifier. In "dry mode" more condensation will be created and the use of a "drain kit" (5304480570) is recommended.

- **Intelligence** -- Your unit has an on board computer that utilizes real time diagnostics to prolong the life of your unit. There is an LED indicator on the control board, behind the front panel, that will flash an error code if the unit has detected some kind of faulty condition. In many cases, the unit will automatically clear the fault condition and continue operating with no interruption. In some cases, the condition cannot be cleared and the unit will require service. In those cases, an "Fx" failure mode will be displayed on the digital display. For a detailed list of all error codes and "Fx" conditions, see Table 5 (page12) - Status LED Indicator Definitions for further details.

- **Memory** -- Your unit also has memory. If power is lost, all of the control settings (setpoint, mode, fan speed, on/off and configuration) are remembered. So when power is restored, the unit will start back up in the mode (and configuration) it was in, when power was lost.

- **Quiet Design** -- Not only does the unit have 2 fan motors and a tangential blower wheel for optimum sound, the indoor fan will always run a minimum of 10 seconds before the compressor, to help reduce the sound of the compressor starting.

- **Random Compressor Restart** -- To help prevent power surges after a power outage (many PTACs starting at the same time), the compressor is equipped with a 2 minutes 45 seconds to 3 minutes 15 seconds random restart delay feature. Whenever the unit is plugged in, or power has been restarted, a random compressor restart will occur to help avoid power surges.

- **Automatic Room Freeze Protection** -- This protection feature will automatically ensure the indoor temperature does not fall below freezing. When your PTAC is configured for freeze protection (which is the default condition), then whenever power is supplied to the unit, if the unit senses temperature below 40°F, the fan motor and electric heater are turned on and will warm the room to 50°F. Freeze protection can be switched off (please see page 9), change the configuration switch to turn the feature off (see section on unit configuration).

- **Automatic Quick Warm--Up (for heat pump models only)** -- If the room temperature falls to 5°F below the set point temperature, the reverse cycle heat is shut off and the electric strip heat is turned on for one cycle, until room temperature rises.

- **Dual-8 Display and LED Display** -- Two 8-segment nixie tubes, 13 LED indicators (They are HIGH, MED, LOW, AUTO, COOL, FAN, HEAT, ON/OFF, SETPOINT, INDOOR, STATUS and TIMER)

- **Fan Configure for Optimization of Selected Application** -- The unit can be optimized to selected application by configuring the fan to run in continuous mode or cycle on and off with the compressor and electric heater (can be different for both heating and cooling modes). In cycle mode, the fan will continue to run after the compressor or electric heater stops in order to blow off any residual heat or cool left on coil.

- **Fan Motors-Permanently Lubricated** -- The unit have two fan motors for quiet operation and maximum operating efficiency. Motors are permanently lubricated to reduce maintenance and totally enclosed to keep dirt and water out of the motor windings.

- **Outdoor Fan** -- The unit automatically selects the most efficient speed for the outdoor fan. The operating sound level is lower when the outdoor fan can operate in low speed yet there are situations where it must operate in high speed. The unit changes the fan speed automatically.

- **Indoor Fan Speed Selections-HIGH/LOW** -- The unit automatically selects the most efficient speed for the outdoor fan. The operating sound level is lower when the outdoor fan can operate in low speed yet there are situations where it must operate in high speed. The unit changes the fan speed automatically.

INSTALLATION

Proper installation is the responsibility of the installer. Product failure due to improper installation is not covered under Warranty.

CHASSIS INSTALLATION

When units are shipped with a sleeve:

1. Remove shipping tape if they are applied.
2. Remove front panel. See Fig.10.
3. Unscrew four screws which connect the main unit with sleeve. The screws location can be referred to Fig.11.
4. Pull out the unit from the wall sleeve.
5. Check the level of the wall sleeve for proper drainage. The wall sleeve should be level from side to side. There should be a 1/4" pitch from inside to outside for proper drainage.
DO NOT SLOPE THE WALL SLEEVE TOWARD THE ROOM.
6. Install sleeve into the wall (please see Installation Instructions of PTAC Sleeve for details).

Note: We recommend always to use a Frigidaire sleeve.

When units are shipped without a sleeve:

In applications where unit is a replacement, it is recommended that a Frigidaire sleeve is used. Your product can retrofit General Electric, Amana, Trane, and Friedrich sleeves/grilles (be sure outdoor grille is installed on the sleeve). See Table 3 for details. For any sleeve retrofit applications, be sure that the foam seals (factory - installed on the tube sheets) provide a good seal between the grille and outdoor coil tube sheets. These foam seals provide a barrier that stops air from the inside mixing with air from the outside (known as air recirculation).

⚠ CAUTION

UNIT DAMAGE AND/OR OPERATION HAZARD

Failure to follow this caution may result in equipment damage or improper operation.

For retrofit applications, foam seals on outdoor coil tube sheets must make a seal between the coil and the grille or loss of performance and premature damage to the major components can result.

Table 3—Retrofit Wall Sleeves

Manufacturer	Wall Sleeve Part Number
General Electric	Metal Sleeve RAB71
	Plastic Sleeve RAB77
Amana	Metal Sleeve WS900B
Trane	Metal Sleeve SLV149
Friedrich	T---Series Metal 111/2---in. Deep Wall Sleeve*
	Standard Depth Wall Sleeve 16 X 42 X 133/4---in. PXWS

* FR-SLEEVE-EXT accessory is required for retrofit into Friedrich (T - Series) wall sleeves.

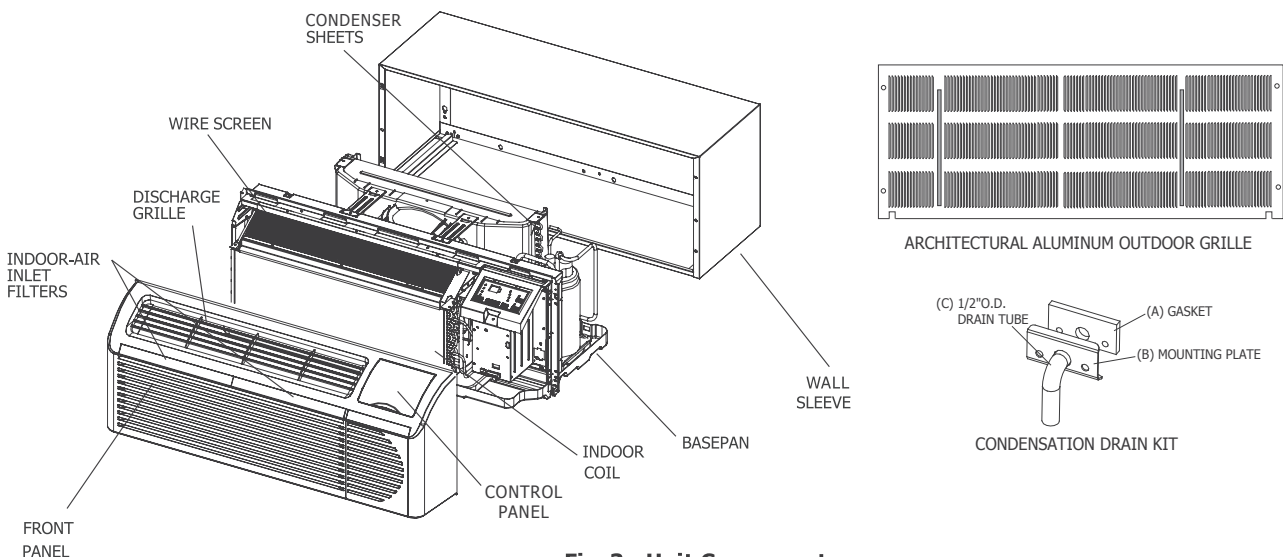

Fig. 3 Unit Components



RETROFIT SLEEVE PREPARATION

IMPORTANT: Inspect wall sleeve thoroughly prior to installation. Manufacturer does not assume responsibility for costs or damages due to defects in sleeve or for improper installation.

⚠ WARNING

ELECTRICAL SHOCK HAZARD

Failure to follow this warning could result in personal injury or death.
Disconnect all power to unit to avoid possible electrical shock during installation.

Remove any existing foam baffles that are installed on competitive outdoor grille, if present. See Fig. 4.

GE Sleeves Only

GE Metal Wall Sleeve - GE metal sleeve is interchangeable with Frigidaire wall sleeve. See Fig. 5.

GE Plastic Sleeve - Remove bottom seal from plastic sleeve. See Fig. 6.

INSTALLATION OF A FRIGIDAIRE WALL SLEEVE USING A NON- FRIGIDAIRE GRILLE

Using a Frigidaire wall sleeve with a non-Frigidaire grille requires installation of an Accessory Baffle Kit (see Fig. 7), which ensures a good seal between the unit and exterior grille to prevent air recirculation. Air recirculation is a large contributor to performance loss and premature damage to major components.
Notes: Frigidaire stamped grille is interchangeable with GE's.

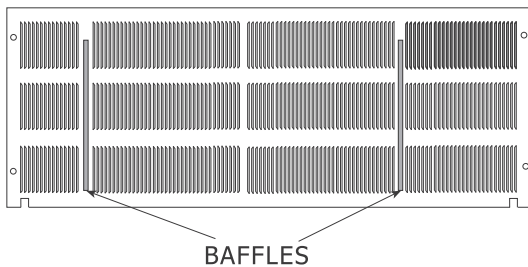

Fig.4-Remove Existing Outdoor Grille Baffles on Competitive Grille

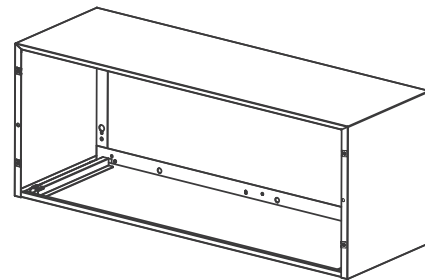

Fig.5-GE Metal Sleeve

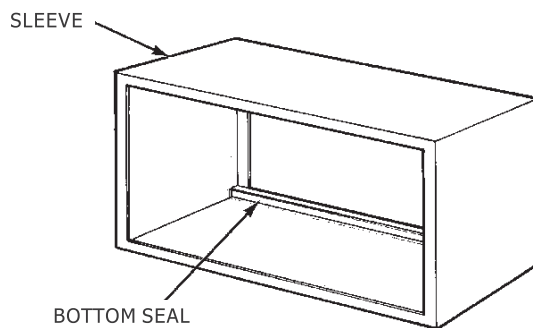

Fig. 6 – Remove Bottom Seal From GE Plastic Sleeve

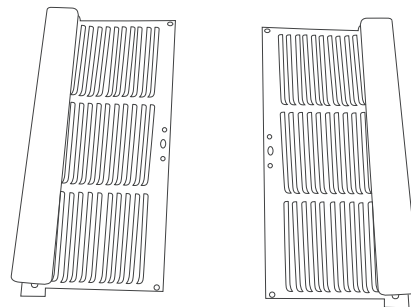

Fig. 7-Accessory Baffle Kit

Note: Contact your units supplier to get the kit, the actual baffle kit may look different from the image shown above.

INSTALLATION

INSTALLATION OF A FRIGIDAIRE PTAC INTO A FRIGIDAIRE WALL SLEEVE

1. Carefully remove shipping tape from the front panel and vent door. See Fig. 8.
2. Remove shipping screw from the vent door, if present. See Fig. 9.
3. Remove front panel. See Fig. 10.
4. Lift unit level and slide unit into wall sleeve until foam seal rest firmly against front of wall sleeve.
5. Secure unit to sleeve with four screws (supplied) through the unit flange holes. See Fig. 11.
6. Reinstall front panel. See Fig. 12.

⚠ CAUTION
UNIT DAMAGE HAZARD
Failure to follow this caution may result in equipment damage or improper operation.
Failure to remove shipping tape and screw will prevent fresh air vent door from opening and may result in damage to vent door cable

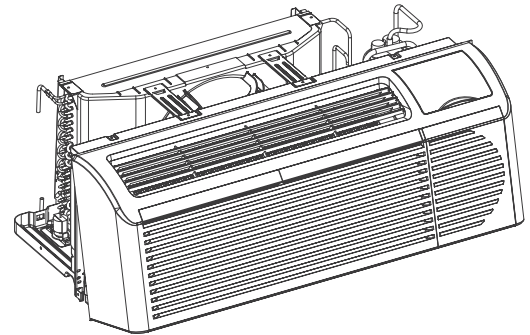

Pull out at the bottom to release it from the tabs (1). Then lift up (2).

Fig. 10 – Removing Front Panel

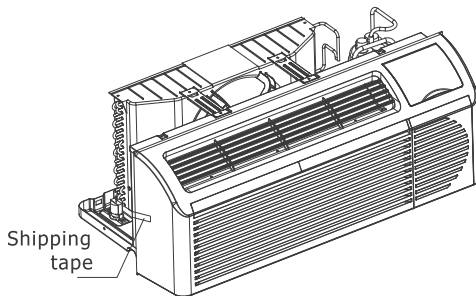

Fig. 8 – Shipping Tape Location

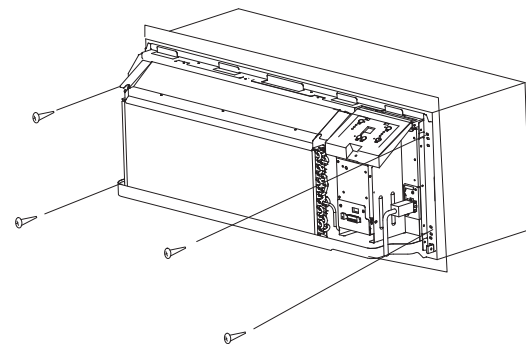

Fig. 11 – Securing Unit

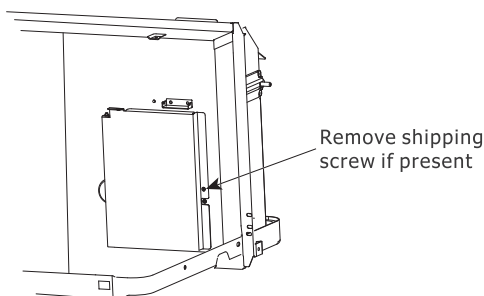
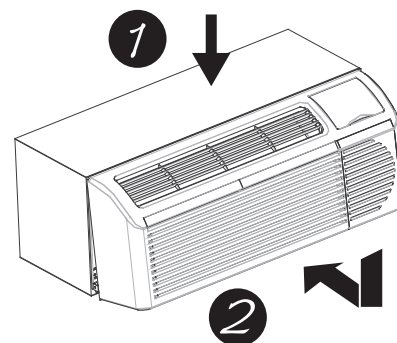

Fig. 9 – Shipping Screw Location



Place tabs over top rail (1). Push Inward at bottom until panel snaps into place (2).

Fig. 12 – Replacing Front Panel

⚠ WARNING

ELECTRICAL SHOCK HAZARD

Failure to follow this warning could result in personal injury or death and/or property damage.

DO NOT alter cord or plug or use an extension cord.

Turn off electrical power before service or installation.

POWER CONNECTION OPTIONS

Appropriate power cord accessory kit is determined by the voltage and amperage of the branch circuit.

IMPORTANT

Be sure that your outlet matches the appropriate blade configuration of the plug and that it is within reach of the service cord. All wiring, including installation of the receptacle, must be in accordance with the NEC and local codes, ordinances and regulations. National codes require the use of an arc fault or leakage current LCDI detection device on all 208/230V power cords. Be sure to select the correct cord for your installation. For 265V units, if power cord accessory option is selected, the cord is only 18" long and must plug into the accessory electrical 265V subbase. Refer to Table 1 for LCDI detection device images.

ALL UNITS

Wire Size

Use recommended wire size given in Table 2 and install a single branch circuit. All wiring must comply with local and national codes. **All units are designed to operate off ONE single branch circuits only.**

NOTE: Use copper conductors only.

Table 1—LCDI DETECTION DEVICE

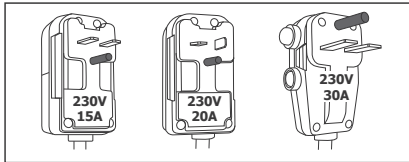

Table 2—SUGGESTED BRANCH CIRCUIT WIRE SIZES*

NAMEPLATE AMPS	AWG WIRE SIZE +
7.0 to 12	14
12.1 to 16	12
16.1 to 24	10

LEGEND

AWG ---American Wire Gauge
 * Single circuit from main box.
 + Based on copper wire at 60 °C temperature rating.

Grounding

For safety and protection, the unit is grounded through the service cord plug or through separate ground wire provided on hard wired units. Be sure that the branch circuit or general purpose outlet is grounded.

VOLTAGE SUPPLY

Check voltage supply at outlet. For satisfactory results, the voltage range must always be within the ranges found on the data information plate.

Cord - connected Units

The 250-V field supplied outlet must match the plug for the standard 208/230-V units and be within reach of the service cord. The standard cord-connected 265-V units require an accessory electrical subbase for operation. Refer to Table 3 for proper receptacle and fuse type.

Power Cord Protection

The power cord for 208/230V units provide power cord fire protection. Unit power automatically disconnects when unsafe conditions are detected. Power to the unit can be restored by pressing the reset button on plug head.

Upon completion of unit installation for 208/230V models, an operational check should be performed using the TEST/RESET buttons on the plug head.

NOTE: The 265V models do not incorporate this feature as they require use of an electrical subbase accessory.

Table 3—RECEPTACLES AND FUSE TYPES - 250, 277 VOLTS

RECEPTACLE				
AMPS	20	30	20	30
RATED VOLTS	250	250	277	277
TIME-DELAY TYPE FUSE (or HACR Circuit Breaker)	20*	30	20	30

LEGEND

HACR ---Heating, Air Conditioning, Refrigeration
 * May be used for 15---amp applications

SYSTEM CONFIGURATION

VENTILATION CONTROL

The ventilation control lever is located at left side of unit, behind the front panel.

NOTE: The vent door shipping screw must be removed before using vent control lever. See Installation Instructions.

When set at **CLOSE**, only the air inside the room is circulated and filtered.

When set at **OPEN**, outdoor air will be drawn into room.

Energy Tip: Keep the vent control at **CLOSE**. Room air will be filtered and circulated.

Vent Control
(Pull lever through label
to operate.)

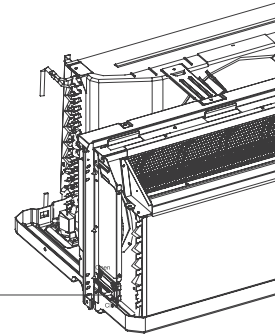

Fig. 13 – Ventilation Control Location

ADJUSTING AIR DIRECTION (For Ducted Installations Only)

To adjust air direction:

1. Remove front panel. See Fig. 10.
2. Remove louver screws that hold louver insert in place (from back side of front panel). See Fig. 14.
3. Turn louver insert and rotate 180°. See Fig. 18.
4. Replace louver insert.
5. Replace screws and front panel.

NOTE: Upward air direction should only be used on ducted installations.

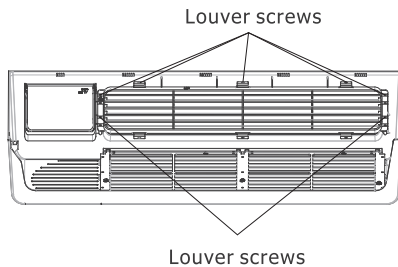

Fig. 14 – Backside of Front Panel

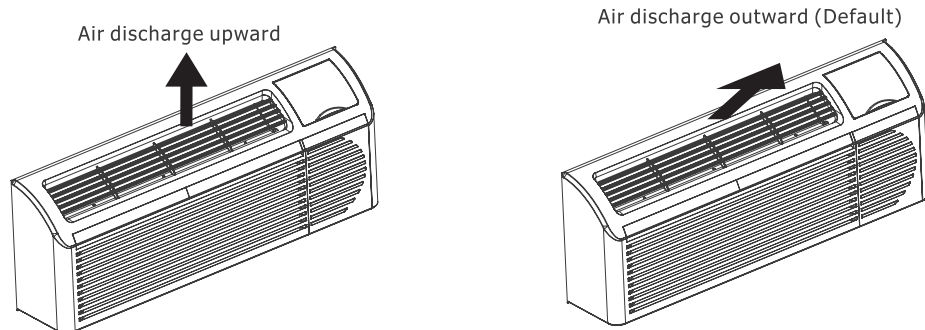

Fig. 15 – Adjusting Louvers

SYSTEM CONFIGURATION

DIP SWITCHES

Auxiliary dip switch controls are located behind the front panel, through an opening below the control panel.

To access, remove front panel. See Fig. 10.

Dip switches are accessible without opening the control box. Unit must be powered **OFF** to effectively change their status.

Factory settings for dip switches will be in the **DOWN** position. See Table 4 - Dip Switch Functions for functions of each dip switch position.

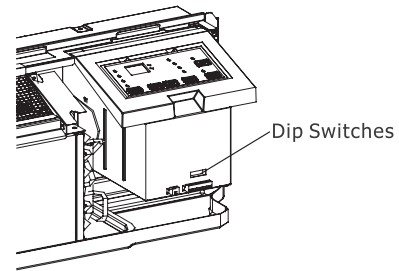

Fig.16 –Dipswitch Location on Unit

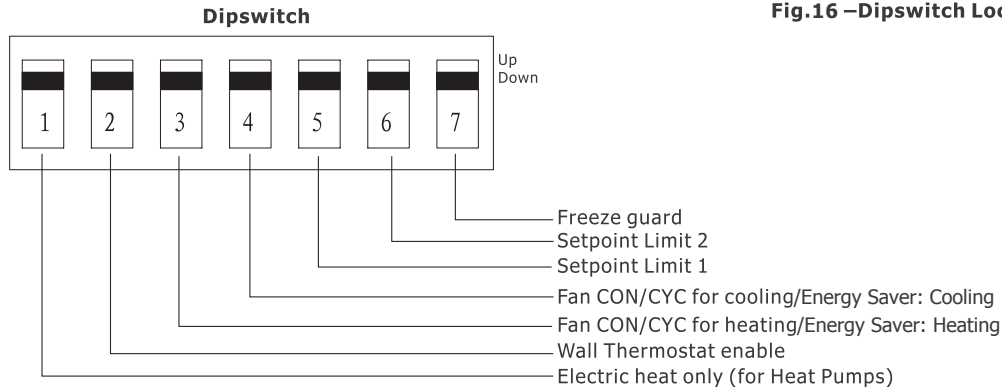

Fig.17 –Dip Switches

Table 4—DIP SWITCH FUNCTIONS

No.	UP		DOWN		DEFAULT	REMARKS
1	Electric Heat Only		Heat Pump		DOWN	For Heat Pump unit only
2	Wall Thermostat Enable		Control Panel Enable		DOWN	
3	Fan Continuous Run for Heating		Fan Cycle for Heat		DOWN	
4	Fan Cycle for Cool		Fan Continuous Run for Cooling		DOWN	
5*6	UP*UP 68---75°F 20---24°C	UP*DOWN 63---80°F 18---28°C	DOWN*UP 65---78°F 19---26°C	DOWN*DOWN 61---86°F 16---30°C (full range)	DOWN*DOWN 61---86°F 16---30°C	Two configurations (5*6) Combine to select set point range. When set point limit set, display always shows full range.
7	Freeze Guard Disable		Freeze Guard Enable		DOWN	

1. Electric Heating Only / Emergency Heat (For Heat Pump Units Only)

This setting is typically used for Emergency Heating.

2. Wall Thermostat Enable

A wired wall thermostat can be connected to the unit. The dip switch must be adjusted accordingly in order to allow the wall thermostat control of the unit. When in wall thermostat mode, the control panel will be disabled.

3. Energy Saver Dip Switches (Heating mode)

Allows the fan to operate in continuous or cycle modes while the unit is in heating mode (continuous or cycle):
CON (Continuous)

Allows fan to run continuously, circulating air even when the temperature setting has been satisfied.

CYC (Cycle)/Energy Saver

This setting allows the fan to cycle on and off with the compressor or electric heater. The fan stops a short time after the temperature setting is satisfied. This is the most efficient mode for electrical usage.

4. Energy Saver Dip Switches (Cooling mode)

Allows the fan to operate in continuous or cycle modes while the unit is in cooling mode (continuous or cycle).

5*6. Setpoint Temperature Limits

Provides a range of temperature control.

7. Room Freeze Protection

If the unit senses a room temperature below 40°F, the fan motor and electric strip heat will turn on and warm the room to 50°F. The fan stops a short time after the temperature is satisfied.

KEYPAD CONFIGURATION

Keypad Configuration

You can customize your unit additionally using the keypad configuration options.

To enter Keypad configuration

Connect the unit to power. Press and hold the "fan speed" and the "V" for 5 continuous seconds, within 30 seconds of the unit being powered up. If the unit has had power for more than 30 continuous seconds, keypad configuration cannot be made.

To scroll through the Keypad Configuration Options

Press and release the "fan speed" to select the keypad configurations.

The stored value will be displayed.

To modify configuration settings

Press and release the Setpoint "Λ" or Setpoint "V" buttons.

To exit Keypad Configuration

Keypad Configuration will end on its own 30 seconds after the last button press or when the "mode" on the Keypad is pressed.

There are 4 configuration options:

1. Fahrenheit/Celsius Display Switch:

Change between degrees Fahrenheit and Celsius on the display. An "F" indicates Fahrenheit display and 'C' indicates Celsius. Default is degrees "F".

2. Indoor Air Temperature Sensor Biasing for Cooling mode:

Sometimes known as an anticipator, the air temperature sensor bias is used to adjust the room air temperature reading when in cooling mode. (Not normally required.)

3. Indoor Air Temperature Sensor Biasing for Heating mode:

Sometimes known as an anticipator, the air temperature sensor bias is used to adjust the room air temperature reading when in heating mode. (Not normally required.)

4. Indoor Temperature Display:

Change between showing the setpoint or desired temperature during heating and cooling modes (SP) or displaying the actual room temperature during heating and cooling modes (AA). SP mode is the default mode.

- If SP is selected the desired setpoint temperature will be displayed during heating and cooling modes, regardless of what the actual temperature is in the room.
- If AA mode is selected, the room temperature will be displayed during heating, cooling and fan only modes.
- If the mode button has been changed to either heating or cooling modes, setpoint will be displayed for 10 seconds. After the 10 seconds, the room temperature will again be displayed.
- If the on/off button is depressed (when the unit is off) and the last mode was either cooling or heating mode, the setpoint will be displayed for 10 seconds before displaying room temperature.
- During heating and cooling modes, if either the up or down setpoint key is depressed, the display will show the setpoint for 10 seconds. Then the room temperature will be displayed again.

Switchover between Emergency Auto Cooling Allowed and Emergency Auto Cooling Rejected:

- Press "Λ" or "V" to switch between the display of Emergency Auto Cooling Allowed and Emergency Auto Cooling Rejected.
- Emergency Auto Cooling Allowed: the diode displays CA.
- Emergency Auto Cooling Rejected: the diode displays CD.

Auto cooling operation:

If this function is activated and room temperature reaches 85°F while the unit is in the "STOP" setting, the unit will automatically start in air conditioning operation and will shut off when the room temperature reach 80°F.

OPERATION

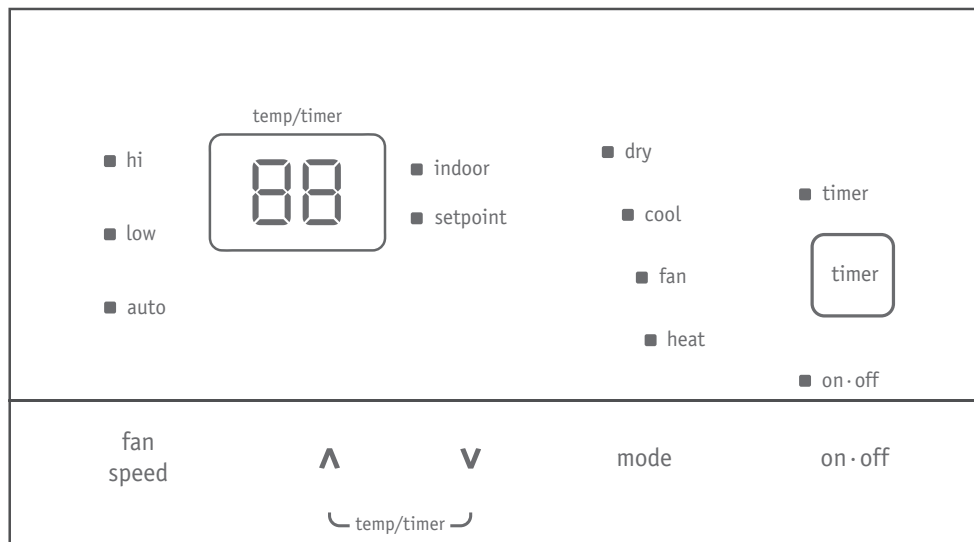

Fig. 22 – PTAC CONTROLS

ABOUT THE CONTROLS ON YOUR UNIT

1. **"ON-OFF"** : It is used for turning the unit ON / OFF.
2. **"mode"** : It is used for switching between Dry, Cool, Fan and Heat mode.
3. **"^"** is used for increasing temperature or timer setting.
4. **"v"** is used for decreasing temperature or timer setting.
5. **"fan speed"** : It is used for setting high, low or auto fan speed. The corresponding LED will be lit when selected.
6. **"timer"** : It is used for setting the timer function.

7. Timer function

- (1) **Timer ON:** When the unit is off, timer ON can be set. Setting range is 0.5~24h. When timer ON time is reached, the system will operate according to the set mode.
- (2) **Timer OFF:** When the unit is off, timer OFF can be set. Setting range is 0.5~24h. When timer OFF time is reached, the system will stop operation.
- (3) **Timer setting:** Press "timer" to set timer function and "timer" icon will be on. The time can be adjusted by pressing "Λ" or "V" buttons.
The range of timer setting is from 0.5h to 24h.
5 seconds after timer setting, the timer function will be activated and "timer" icon will be on.
- (4) **Timer preview:** When timer function has been set, press "timer" to preview the remaining time of timer.
- (5) If timer function has been set, turning the unit or power on/off failure will cancel timer setting.

AUXILIARY CONTROLS

WALL THERMOSTAT TERMINAL

IMPORTANT: Only trained, qualified personnel should access the electrical panel on unit and install electrical accessories. Please contact your local electrical contractor, dealer, or distributor for assistance.

Thermostat Wire Routing

Thermostat wire is field supplied. Recommended wire gauge is 18 to 20 gauge solid thermostat wire.

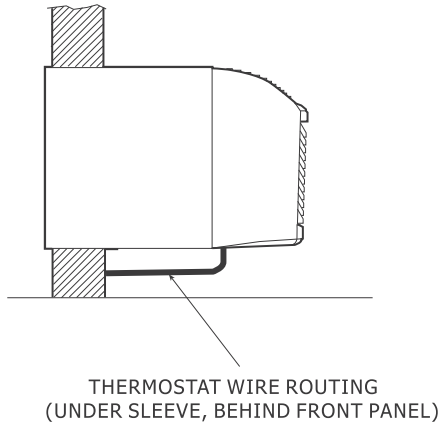

Fig. 18 – Proper Wire Routing Beneath Unit

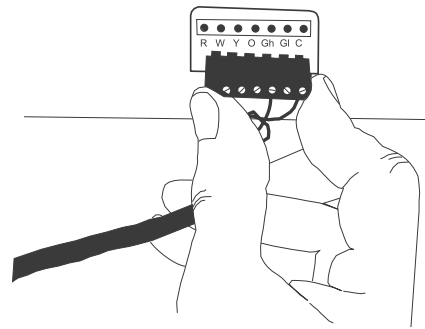

Fig. 19 –Terminal Connector Removal and Replacement

Wiring Thermostat To Unit

Wire wall thermostat input as defined in Fig. 21.

NOTE: Terminal connector can be removed and replaced to simplify the wiring. See Fig.19.

NOTE: For heat pump models, anytime there is a second-stage call for heating from the wall thermostat, the unit will automatically switch over to electric heating.

Install Thermostat Wiring

1. Check to be sure power to unit is disconnected.
2. Pull terminal connector to remove
- NOTE:** Terminal connector can be removed and replaced to simplify thermostat wiring.
3. Connect wires from the thermostat to terminals on unit terminal connector.
4. Reinstall terminal connector.
5. Ensure that unit is configured for wall thermostat enable.
6. Replace control panel label with control panel guard.
7. Restore power to unit.

NOTE: Refer to thermostat installation instructions for details on installing wall thermostat.

NOTE: For thermostats that have two fan speed output (Low fan or Hi fan), the fan speed is determined by how the terminal connector is wired. If Low fan is desired, wire the GL output from the thermostat to GL on the unit's terminal block. If Hi fan is desired, wire the GH output from the thermostat to GH on the unit's terminal block.

NOTE: After proper installation, if your thermostat is not working properly, refer to the Trouble Shooting section on page 17.

AUXILIARY CONTROLS

TERMINAL CONNECTIONS

The wall thermostat terminal block is located behind the front panel and is easily accessible on front of control panel.

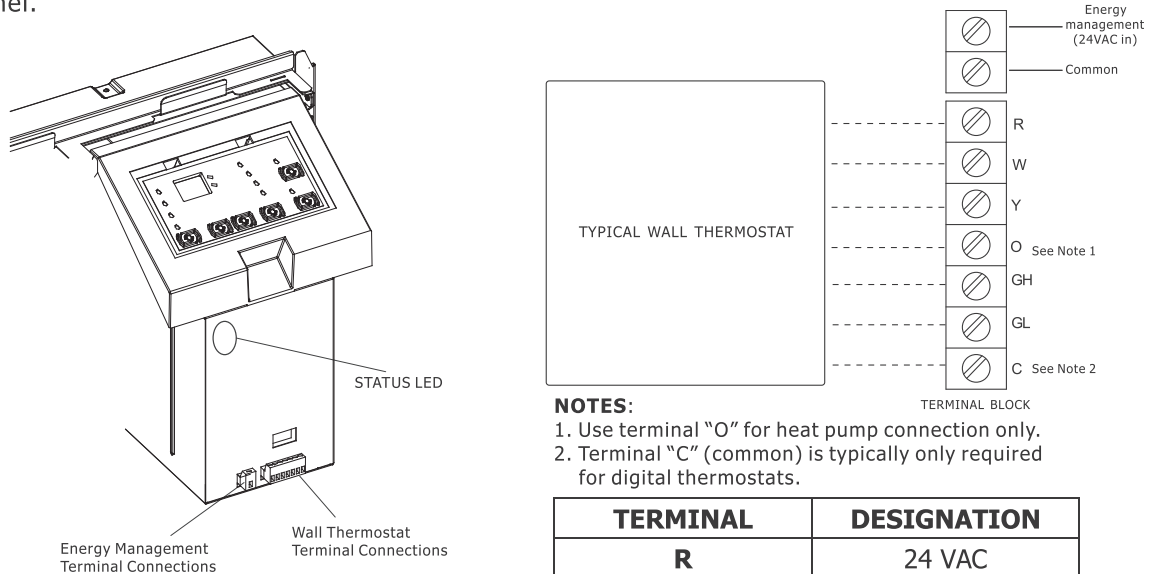

Fig.20– Terminal Connector and Status LED Location

⚠ CAUTION

UNIT DAMAGE HAZARD
Failure to follow this caution may result in equipment damage or improper operation.

Improper wiring may damage unit electronics. Common busing is not permitted. Damage or erratic operation may result.

NOTES:
1. Use terminal "O" for heat pump connection only.
2. Terminal "C" (common) is typically only required for digital thermostats.

TERMINAL	DESIGNATION
R	24 VAC
W	Electric Heat
Y	Compressor
O	Reversing Valve
GH	High Fan
GL	Low Fan
C	Common

NOTE: Any incorrect input combinations will be captured as thermostat wiring failures and will light the STATUS LED indicator on main board (see Intelligent Self - Checking Control section)

Fig.21–Wiring Connections

ENERGY MANAGEMENT INPUT (FRONT DESK CONTROL)

The controller can handle a switch signal from remote energy management input, called EM signal or front desk control. Input must be 24VAC. If system receives a 24VAC signal, it will turn unit off; otherwise, the unit runs in normal control. This function will be disabled under Freeze Guard protection. See Fig. 20 and Fig. 21 for terminal connections.

INTELLIGENT SELF-CHECKING CONTROL

Your Frigidaire PTAC has a computer on-board that continuously checks key components of the unit to ensure they are operating properly. Under normal operation, unit status indicator (STATUS, on main PCB), light is steadily ON. If there is a major problem, the unit will shut down and display a diagnostic failure code on the unit's display. If it is a minor error and the unit can correct it by itself, the diagnostic code will be flashed on the status LED that can easily be seen when the front panel is removed (see Fig.23). Failure STATUS codes are defined in the table below

Table 5—STATUS LED Indicator Definitions

1	Indoor air temp sensor open/short	8-segment display 'F1', with STATUS light flash 1 times and off 3 sec, repeat	NOTE: When status light is flashing, it will be ON for 1 seconds and OFF for another 1 seconds.
2	Indoor coil sensor open or short	8-segment display 'F2', with STATUS light flash 2 times and off 3 sec, repeat	
3	Outdoor coil sensor open/short	8-segment display 'F4', with STATUS light flash 3 times and off 3 sec, repeat	
4	Freeze Guard protection	8-segment display 'FP'	
5	Indoor coil freeze protection	STATUS light flash 5 times and off 3 sec, repeat	
6	Outdoor coil high temp protection	STATUS light flash 6 times and off 3 sec, repeat	
7	Defrost (heat pump type)	STATUS light flash 7 times and off 3 sec, repeat	
8	Indoor coil high temp protection	STATUS light flash 8 times and off 3 sec, repeat	
9	Thermostat wiring error	STATUS light flash 9 times and off 3 sec, repeat	

CARE AND CLEANING

FRONT PANEL AND CASE

Turn unit off and disconnect power supply.

To clean, use water and a mild detergent. **DO NOT** use bleach or abrasives. Some commercial cleaners may damage the plastic parts.

OUTDOOR COIL

Coil on outdoor side of unit should be checked annually. Unit will need to be removed from its sleeve to inspect dirt build-up that can occur inside of the coil. If clogged with dirt or soot, coil should be professionally cleaned. Under extreme conditions, more frequent cleanings may be required.

Clean the coils and basepan with a soft brush and compressed air or vacuum. A pressure washer may also be used, but be aware that the aluminium fins must not be bent. Use a gentle up and down motion in the direction of the vertical aluminium fins when pressure washing coils.

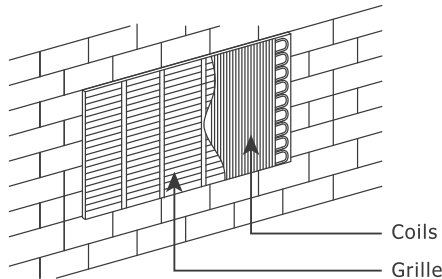

Clean inside and outside of outdoor coils regularly.

Fig. 23 – Outdoor Coil

⚠ CAUTION

UNIT DAMAGE HAZARD

Product failure due to improper care or lack of maintenance is not covered by warranty.

Airflow restriction may cause damage to the unit.

BASE PAN

Check base pan periodically and clean, if necessary.

AIR FILTERS

IMPORTANT: TURN UNIT OFF BEFORE CLEANING

⚠ CAUTION

UNIT DAMAGE HAZARD

Product failure due to improper care or lack of maintenance is not covered by warranty.

Do not operate unit without filters in place. If a filter becomes torn or damaged, it should be replaced immediately.

Operating without filters in place or with damaged filters will allow dirt and dust to reach indoor coil and reduce cooling, heating, airflow and efficiency of unit. Airflow restriction may cause damage to unit.

To maintain unit efficiency clean the filters at least every 30 days (or sooner depending on application). Clogged filters reduce cooling, heating and airflow.

Keeping filters clean will:

- Decrease cost of operation.
- Save energy.
- Prevent clogged indoor coil.
- Reduce risk of premature component failure.

To Clean Air Filters:

- Vacuum off heavy soil.
- Run water through filters.
- Dry thoroughly before replacing.

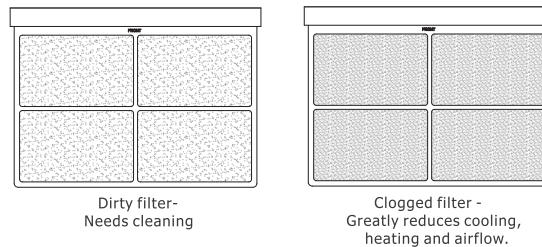

Fig. 24 – Identifying Clogged Filter

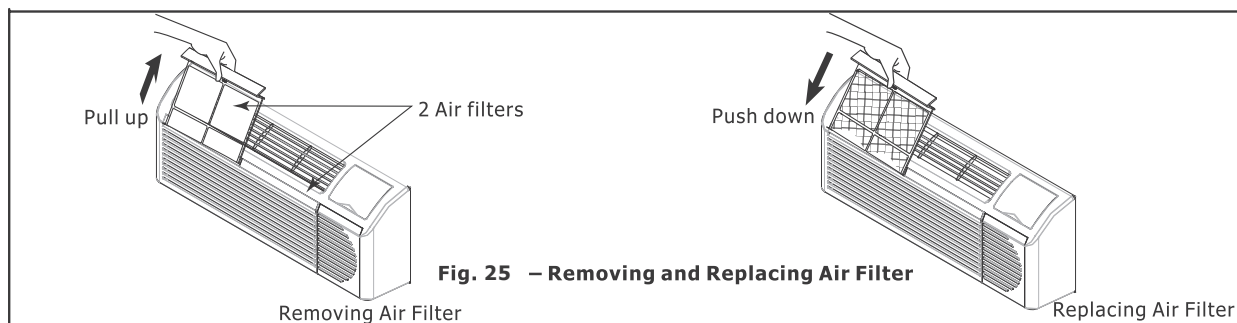

Fig. 25 – Removing and Replacing Air Filter

PREVENTATIVE MAINTENANCE

Preventative maintenance is essential to proper unit operation, efficiency and longevity. To ensure equipment operates properly, it must be properly maintained. Equipment operation should be checked and verified several times during each year. During regular unit inspection and maintenance, follow the guidelines below:

- Clean basepan and outdoor vent filter.
- Clean outdoor orifice and fan.
- Clean indoor coil. (Never use high pressure spray on indoor coils.)
- Clean indoor fan, wire screen and front panel. (Best to use compressed air.)
- Clean or install new indoor - air inlet filter(s).
- Clean wall sleeve and outdoor grille.
- Inspect cord and receptacle.
- Secure electrical connections.
- Ensure front panel is properly mounted and not damaged.
- Ensure wall sleeve is installed properly.
- Ensure heat and cool cycles operate properly.

TROUBLESHOOTING

POSSIBLE CAUSES	SOLUTIONS
<p>UNIT DOES NOT START</p> <ul style="list-style-type: none"> • Unit may have become unplugged • Circuit breaker may have been tripped • Unit may be off or in wall thermostat mode. Check section on dipswitch settings to verify dipswitches are set properly. • Unit may be in a protection or diagnostic failure mode. See section on Intelligent Self-checking Control. 	<ul style="list-style-type: none"> • Check that plug is plugged securely in wall receptacle. Note: LCDI plug has a test/reset button on it. Make sure that the LCDI plug has not tripped. • Replace the fuse. See Note 1. • Reset circuit breaker. See Note 1. • Turn unit on (bottom right button on keypad). Note: If the unit turns on, the LED will be green. If the unit is off, the LED will be red. If there is no LED on, there is a problem with power or damage to the control.
<p>UNIT NOT COOLING/HEATING ROOM</p> <ul style="list-style-type: none"> • Unit air discharge section is blocked • Temperature setting is not high or low enough. Note: Set point limits may not allow the unit to heat or cool the room to the desired temperature. Check section on dipswitch settings. • Unit air filters are dirty. • Room is excessively hot or cold when unit is started. • Vent door left open. • Unit may be in a protection or diagnostic failure mode. Check section on Intelligent Self-checking Control. • Compressor is not running. 	<ul style="list-style-type: none"> • Make sure that curtains, blinds or furniture are not restricting or blocking unit airflow. • Reset to a lower or higher temperature setting. • Remove and clean filters. • Allow sufficient amount of time for unit to heat or cool the room. Start heating or cooling early before outdoor temperature, cooking heat or gatherings of people make room uncomfortable. • Close vent door. • Check dipswitch settings for desired comfort. • There is a protective time delay (approx.3 minutes) on starting the compressor after a power outage (or restarting after it has been turned off), to prevent tripping of the compressor overload.
<p>DISPLAY HAS STRANGE NUMBERS/CHARACTERS ON IT</p>	<ul style="list-style-type: none"> • The unit may be in a diagnostic condition. Check Intelligent Self-Checking Control section to determine if unit has had a failure. • The unit may be set for °C (instead of °F), see the keypad configuration section
<p>WATER DRIPPING OUTSIDE</p>	<ul style="list-style-type: none"> • If a drain kit has not been installed, condensation runoff during very hot and humid weather is normal. See Note 2. If a drain kit has been installed and is connected to a drain system, check gaskets and fittings around drain for leaks and plugs.
<p>WATER DRIPPING INSIDE</p> <ul style="list-style-type: none"> • Wall sleeve is not installed level 	<ul style="list-style-type: none"> • Wall sleeve must be installed level for proper drainage of condensation. Check that installation is level and make any necessary adjustments.
<p>ICE OR FROST FORMS ON INDOOR COIL</p> <ul style="list-style-type: none"> • Low outdoor temperature • Dirty filters 	<ul style="list-style-type: none"> • When outdoor temperature is approximately 55°F or below, frost may form on the indoor coil when unit is in Cooling mode. Switch unit to FAN operation until ice or frost melts. • Remove and clean filters.
<p>COMPRESSOR PROTECTION</p> <ul style="list-style-type: none"> • Power may have cycled, so compressor is in a restart protection 	<ul style="list-style-type: none"> • Random Compressor restart-Whenever the unit is plugged in, or power has been restarted, a random compressor restart will occur. After a power outage, the compressor will restart after approximately 3 minutes. • Compressor Protection-To prevent short cycling of the compressor, there is a random startup delay of 3 minutes and a minimum compressor run time of 3 minutes.

NOTES:

1. If circuit breaker is tripped or fuse is blown more than once, contact a qualified electrician.
2. If unit is installed where condensation drainage could drip in an undesirable location, an accessory drain kit should be installed and connected to drain system.



SAFETY PRECAUTIONS

DANGER! Avoid Serious Injury or Death

1. Do not attempt to install air conditioner by yourself.
2. This air conditioner contains no user-serviceable parts. Always call an authorized Electrolux servicer for repairs.
3. When moving the air conditioner, always call an authorized Electrolux servicer for disconnection and re-installation.
4. Do not insert or place fingers or objects into the air discharge area in the unit.
5. Do not start or stop the air conditioner by unplugging the power cord or turning off the power at the electrical box.
6. Do not cut or damage the power cord.
7. If the power cord is damaged it should only be replaced by an authorized Electrolux servicer.
8. In the event of a malfunction (sparks, burning smell, etc.) immediately stop the operation, disconnect the power cord, and call an authorized Electrolux servicer.
9. Do not operate the air conditioners with wet hands.
10. Do not pull on the power cord.
11. Do not drink any water that is drained from the air conditioners.

CAUTION! Avoid Injury or damage to the unit or other property

1. Provide occasional ventilation during use. Do not direct airflow at fireplaces or other heat related sources as this could cause flare ups or make units run excessively.
2. Do not place containers containing water on unit.
3. Turn off the air conditioner at the power source when it will not be used for an extended period of time.
4. Periodically check the condition of the unit's installation base for any damage.
5. Do not apply heavy pressure to the radiator fins of the units.
6. Operate the unit with air filters in place.
7. Do not block or cover the intake grille, discharge area and outlet ports.
8. Ensure that any electrical/electronic equipment is one yard away from the unit.
9. Do not use or store flammable gases near the unit.

INSTALLATION WARNINGS

1. Carefully read the installation section of this manual before beginning.
2. Follow each step as shown.
3. Observe all local, state, and national electrical codes and by qualified, licensed, authorized personnel only.
4. Pay attention to danger and safety notices.

MAJOR APPLIANCE LIMITED WARRANTY

Your appliance is covered by a limited two-year warranty and a limited 3-5 year warranty on the sealed system (the compressor, condenser, evaporator and tubing). For two years from your original date of purchase, Electrolux will pay all costs for repairing or replacing any parts of this appliance that prove to be defective in materials or workmanship when such appliance is installed, used and maintained in accordance with the provided instructions. From the third to the fifth year from your original purchase date, Electrolux will repair or replace any parts in the Sealed Refrigeration System (compressor, condenser, evaporator and tubing) that prove to be defective in materials or workmanship. In years 3-5, the consumer will be responsible for diagnostic, labor and parts costs as well as any removal, transportation and reinstallation expenses which are incurred during service on components other than those covered under the Sealed Refrigeration System 5-year warranty.

Exclusions This warranty does not cover the following:

1. Products with original serial numbers that have been removed, altered or cannot be readily determined.
2. Product that has been transferred from its original owner to another party or removed outside the USA or Canada.
3. Rust on the interior or exterior of the unit.
4. Products purchased "as-is" are not covered by this warranty.
5. Service calls which do not involve malfunction or defects in materials or workmanship, or used other than in accordance with the provided instructions.
6. Service calls to correct the installation of your appliance or to instruct you how to use your appliance.
7. Expenses for making the appliance accessible for servicing, such as removal of trim, cupboards, shelves, etc., which are not a part of the appliance when it is shipped from the factory.
8. Service calls to repair or replace appliance light bulbs, air filters, water filters, other consumables, or knobs, handles, or other cosmetic parts.
9. Surcharges including, but not limited to, any after hour, weekend, or holiday service calls, tolls, ferry trip charges, or mileage expense for service calls to remote areas, including the state of Alaska.
10. Damages to the finish of appliance or facility incurred during installation, including but not limited to floors, cabinets, walls, etc.
11. Damages caused by: services performed by unauthorized service companies; use of parts other than genuine Electrolux parts or parts obtained from persons other than authorized service companies; or external causes such as abuse, misuse, inadequate power supply, accidents, fires, or acts of God.

DISCLAIMER OF IMPLIED WARRANTIES; LIMITATION OF REMEDIES

CUSTOMER'S SOLE AND EXCLUSIVE REMEDY UNDER THIS LIMITED WARRANTY SHALL BE PRODUCT REPAIR OR REPLACEMENT AS PROVIDED HEREIN. CLAIMS BASED ON IMPLIED WARRANTIES, INCLUDING WARRANTIES OF MERCHANTABILITY OR FITNESS FOR A PARTICULAR PURPOSE, ARE LIMITED TO ONE YEAR OR THE SHORTEST PERIOD ALLOWED BY LAW, BUT NOT LESS THAN ONE YEAR. ELECTROLUX SHALL NOT BE LIABLE FOR CONSEQUENTIAL OR INCIDENTAL DAMAGES SUCH AS PROPERTY DAMAGE AND INCIDENTAL EXPENSES RESULTING FROM ANY BREACH OF THIS WRITTEN LIMITED WARRANTY OR ANY IMPLIED WARRANTY. SOME STATES AND PROVINCES DO NOT ALLOW THE EXCLUSION OR LIMITATION OF INCIDENTAL OR CONSEQUENTIAL DAMAGES, OR LIMITATIONS ON THE DURATION OF IMPLIED WARRANTIES, SO THESE LIMITATIONS OR EXCLUSIONS MAY NOT APPLY TO YOU. THIS WRITTEN WARRANTY GIVES YOU SPECIFIC LEGAL RIGHTS. YOU MAY ALSO HAVE OTHER RIGHTS THAT VARY FROM STATE TO STATE.

If You Need Service Keep your receipt, delivery slip, or some other appropriate payment record to establish the warranty period should service be required. If service is performed, it is in your best interest to obtain and keep all receipts. Service under this warranty must be obtained by contacting Electrolux at the addresses or phone numbers below.

This warranty only applies in the USA and Canada. In the USA, your appliance is warranted by Electrolux Major Appliances North America, a division of Electrolux Home Products, Inc. In Canada, your appliance is warranted by Electrolux Canada Corp. Electrolux authorizes no person to change or add to any obligations under this warranty. Obligations for service and parts under this warranty must be performed by Electrolux or an authorized service company. Product features or specifications as described or illustrated are subject to change without notice.

USA

1.866.942.1567

Electrolux Major Appliances-North America
10200 David Taylor Drive
Charlotte NC 28262



Canada

1.866.942.1567

Electrolux Canada Corp.
5855 Terry Fox Way
Mississauga, Ontario, Canada
L5V 3E4

FRIGIDAIRE