

Save This Manual
For Future Reference

SEARS

**owner's
manual**

**MODEL NO.
113.196380**

Serial
Number

Model and serial numbers
may be found at the front
of the base.

You should record both
model and serial number in
a safe place for future use.

**FOR YOUR
SAFETY:**

**READ ALL
INSTRUCTIONS
CAREFULLY**

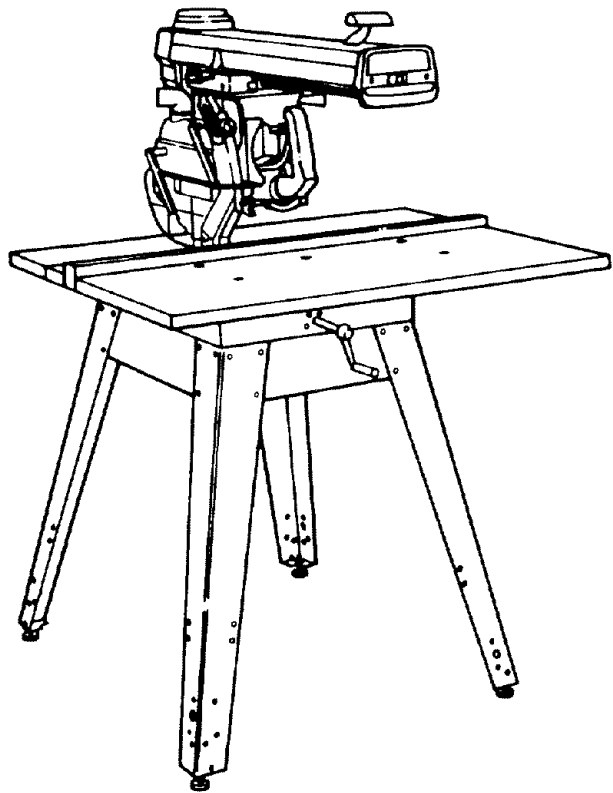

SEARS / CRAFTSMAN

10-INCH RADIAL SAW

- assembly
- operating
- repair parts

Sears Roebuck and Co., Hoffman Estates, IL 60179 U.S.A.

Part No. SP5976

Printed in U.S.A.

Table of Contents

Section Title.....	Page
Safety.....	3
Introduction.....	12
Assembly.....	12
Adjustments.....	19
Alignment.....	28
Controls.....	37
Electrical Connections.....	42
Crosscutting.....	45
Ripping.....	49
Cutting Aides.....	58
Accessories.....	61
Maintenance.....	63
Troubleshooting.....	65
Repair Parts.....	70

FULL ONE YEAR WARRANTY ON CRAFTSMAN STATIONARY TOOL

If, this stationary tool fails due to a defect in material or workmanship within one year from the date of purchase, CONTACT THE NEAREST SEARS SERVICE CENTER IN THE UNITED STATES and Sears will repair it, free of charge. This warranty applies only while this product is in the United States.

If this Radial Saw is used for commercial or rental purposes, this warranty will apply for ninety days from the date of purchase.

This warranty gives you specific legal rights, and you may also have other rights which vary from state to state.

SEARS, ROEBUCK AND CO., DEPT 817WA, Hoffman Estates, IL 60179

This manual has safety information and instructions to help users eliminate or reduce the risk of accidents and injuries, including:

1. Severe cuts, and loss of fingers or other body parts due to contact with the blade.
2. Eye impact injuries, and blindness, from being hit by a thrown workpiece, workpiece chips or pieces of blade.
3. Bodily impact injuries, broken bones, and internal organ damage from being hit by a thrown workpiece
4. Shock or electrocution
5. Burns.

Safety Symbol and Signal Words

An exclamation mark inside a triangle is the safety alert symbol.

It is used to draw attention to safety information in the manual and on the saw. It is followed by a signal word, DANGER, WARNING, or CAUTION, which tells the level of risk:

 **DANGER:** means if the safety information is not followed someone **will** be seriously injured or killed.

 **WARNING:** means if the safety information is not followed someone **could** be seriously injured or killed.

 **CAUTION:** means if the safety information is not followed someone **might** be injured.

Read and follow all safety information and instructions.

Major Hazards

Three major hazards are associated with using the radial arm saw for ripping. They are outfeed zone hazard, kickback, and wrong way feed.

This section only briefly explains these hazards. Read the ripping and crosscutting safety sections for more detailed explanations of these and other hazards.

Outfeed Zone Hazard

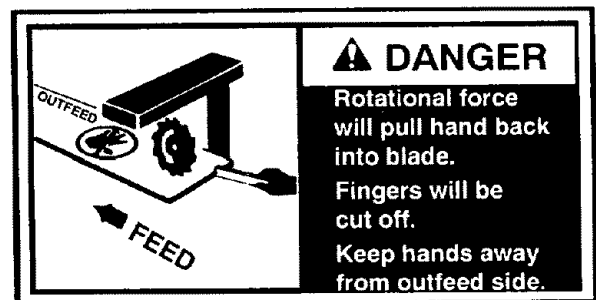

If you reach around the blade to the outfeed side when ripping, and try to hold down or pull the workpiece through to complete a cut, the rotational force of the blade will pull your hand back into the blade.

Fingers will be cut off.

Read and follow the information and instructions under ripping safety.

Safety

Kickback Hazard

Kickback is the uncontrolled propelling of the workpiece back toward the user during ripping.

The cause of kickback is the binding or pinching of the blade in the workpiece. Several conditions can cause the blade to bind or pinch.

When a workpiece kicks back, it could hit hard enough to cause internal organ injury, broken bones, or death.

Read and follow the information and instructions under ripping safety.



Wrong Way Feed Hazard

Wrong way feed is ripping by feeding the workpiece into the outfeed side of the blade.

The rotational force of the blade can grab and pull the workpiece.

Before you can let go or pull back, the force could pull your hand along with the workpiece into the blade. Fingers or hand could be cut off.

The propelled workpiece could hit a bystander, causing severe impact injury or death.

Read and follow the information and instructions under ripping safety.



Guard Function and Features

The guard is a very important safety feature, designed to reduce the risk of injury associated with blade contact. **Install the guard correctly. Follow the specific instructions in the ripping and crosscutting sections to set and use the guard correctly for each type of cut.**

Guard Features Include:

1. A non-moveable **metal upper portion**, (Upper Guard) which is fastened to the motor by the guard clamp screw, and which fully covers the upper half of the blade.
2. A moveable **clear plastic portion**, (Plastic Lower Guard) which partially covers the lower half of the blade. It protects against contact with the side of the blade during crosscutting when blade is in its rearmost position and the guard is resting on the table, so the leading and trailing teeth of the blade are not exposed. It also protects against contact with the outfeed side of the blade during ripping, and acts as a barrier to prevent wrong way feed.
3. A **squeeze trigger** in the saw handle to fully raise the clear plastic guard at the start of a crosscut. **Note:** *This is necessary because the guard will not automatically raise to clear the fence.*
4. A **hold down** to be lowered to just clear the top of the workpiece for ripping. It acts as a barrier to the infeed side of the blade, keeps the workpiece from fluttering, and acts as a sawdust deflector. It is locked/unlocked by the hold down knob.
5. A **ripping knife** to be lowered to the table for ripping. It keeps the workpiece kerf open, thereby reducing blade pinching and the risk of kickback. It also acts as a barrier to the hazardous outfeed side and prevents wrong way feed. It is locked/unlocked by

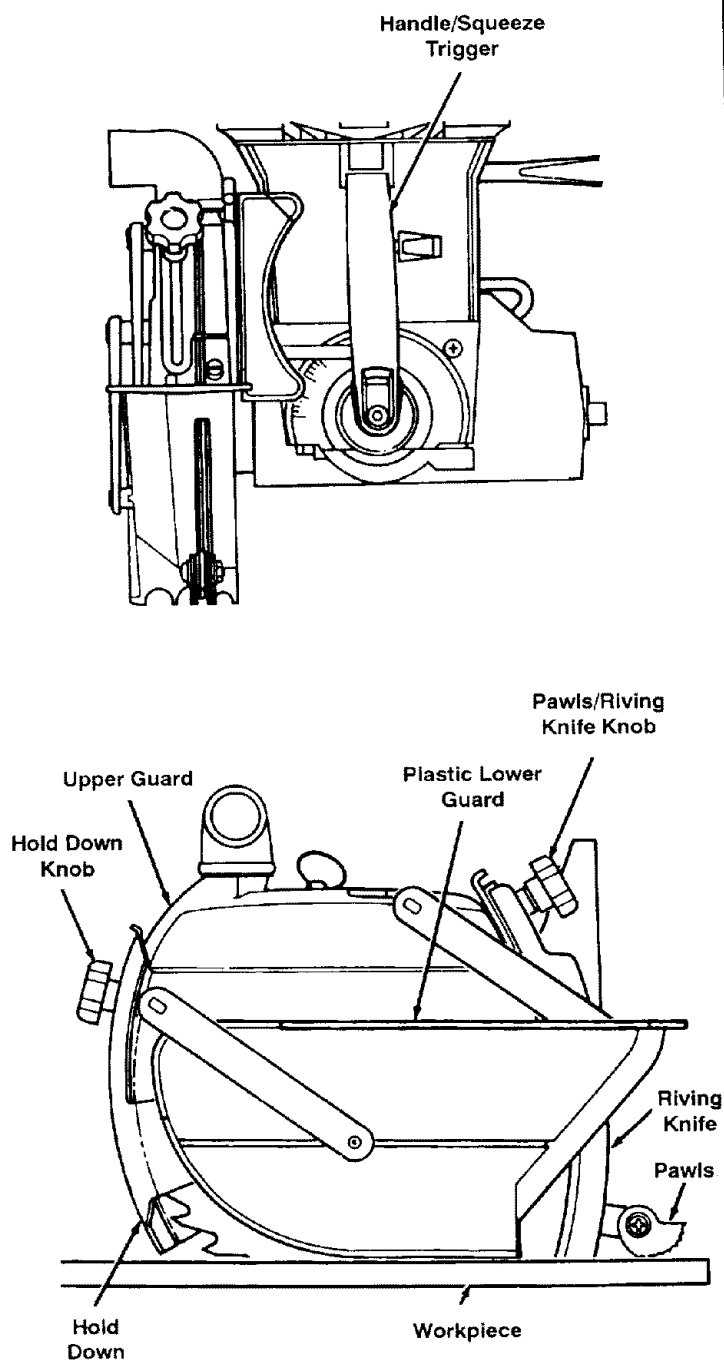

Safety

the riving knife/pawls knob. When lowered for crosscutting, it acts as a barrier to the leading edge of the blade.

6. Set of **pawls** to be lowered to the workpiece surface for ripping. They allow the workpiece to pass freely from infeed to outfeed side, but help stop the kickback motion from outfeed to infeed side by grabbing into the workpiece surface. **Pawls** must be re-set each time a different thickness workpiece is cut.

7. A **guard tab** to manually raise the plastic guard at the start of ripping unusual workpieces whose size/shape do not cause the guard to raise automatically.

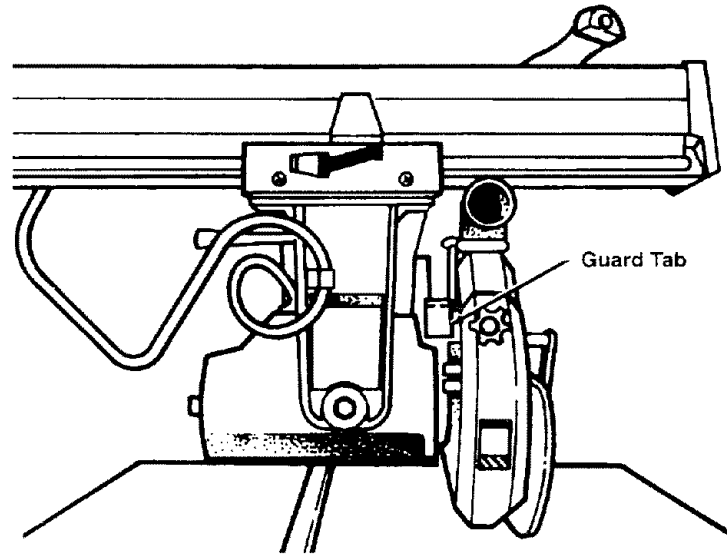

Hazards Associated with Clear Portion of Guard

The following safety information applies to all blades and accessories.

WARNING

Clear plastic portion of guard will not provide any protection during crosscutting if blade is pulled over your hand, or your hand enters blade path from front or rear of blade. Fingers or hand can be cut or cut off.

CAUTION

Clear plastic portion of guard can get caught or jam in fence or table kerfs. Read and follow the warning on the guard:

 **WARNING:**
TO AVOID INJURY
SHUT OFF POWER
BEFORE CLEARING A
JAMMED LOWER GUARD

WARNING

Clear plastic guard will increase risk of certain hazards:

- During rip and bevel cuts, narrow cut-off pieces can be pinched between guard and blade. Cut-off pieces can kickback.
- In bevel position blade teeth are fully exposed. Fingers or hand can be cut off.
- Cut off pieces can jam between guard and blade. Turn saw off and wait for blade to stop before freeing jammed guard or blade.
- Workpiece or cut-off pieces can be violently thrown by blade. Wear safety goggles. Stand out of workpiece path.

Safety Instructions

Read and follow all safety instructions.

Personal Safety Instructions

1. Wear safety goggles labeled "ANSI Z87.1" on the package. It means the goggles meet impact standards set by the American National Standards Institute. Regular eye-glasses are not safety goggles.
2. Wear close fitting clothes, short sleeved shirts, and non-slip shoes. Tie up long hair. Do not wear gloves, ties, jewelry, loose clothing, or long sleeves. These can get caught in the spinning blade and pull body parts into the blade.
3. Wear dust mask to keep from inhaling fine particles.
4. Wear ear protectors, plugs or muffs if you use saw daily.
5. Keep good footing and balance; do not over-reach.

Work Area Safety Instructions

1. Keep children, pets, and visitors out of work area; they could be hit by a thrown workpiece, workpiece chips or pieces of blade.
2. Turn saw off, remove yellow key, and unplug before leaving work area. Do not leave until blade has stopped spinning.
3. Make work area child-proof: remove yellow key to prevent accidental start-up; store key out of sight and reach; lock work area.
4. Keep floors clean and free of sawdust, wax and other slippery materials.
5. Keep work area well lighted and uncluttered.
6. Use saw only in dry area. Do not use in wet or damp areas.

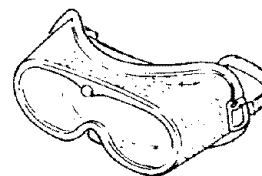

Safety Goggles



Dust Mask

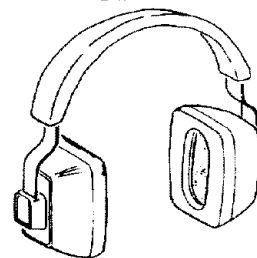

Ear Protectors

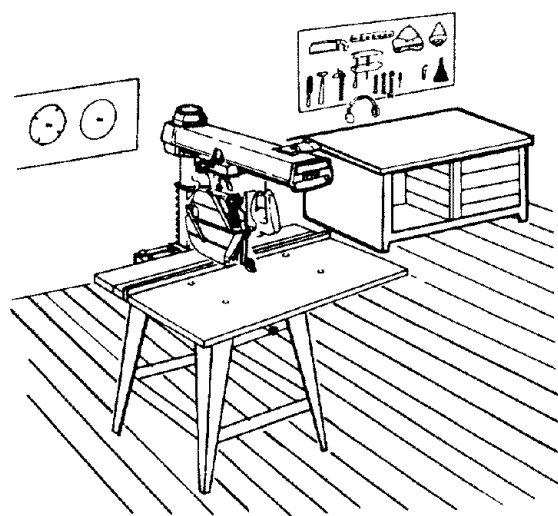

Safety

Saw Safety Instructions

1. Use guard, pawls and riving knife according to instructions. Keep them in working order.
2. Routinely check saw for broken or damaged parts. Repair or replace damaged parts before using saw. Check new or repaired parts for alignment, binding, and correct installation.
3. Unplug saw before doing maintenance, making adjustments, correcting alignment, or changing blades.
4. Do not force saw. Use saw, blades and accessories only as intended.
5. Have yellow key out and saw switched off before plugging in power cord.
6. Before turning on saw, clear table of all objects except workpiece to be cut and necessary fixtures, clamps, or feather-boards.
7. If blade jams, turn saw off immediately, remove yellow key, the free blade. Do not try to free blade with saw on.
8. Turn saw off if it vibrates too much or makes an odd sound. Correct any problem before restarting saw.
9. Do not layout, assemble, or setup work with saw on, or while blade is spinning.
10. Keep saw table clean.
11. Store items away from saw. Do not climb on saw or stand on saw table to reach items because saw can tip over.

Workpiece Safety Instructions

1. Cut only wood, woodlike or plastic materials. Do not cut metal.

2. Cut only one workpiece at a time. Stacking or placing workpieces edge to edge can cause user to lose control of workpiece.

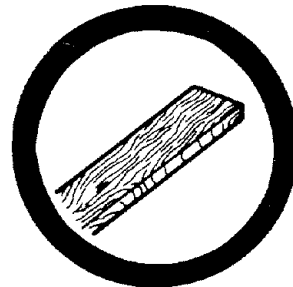

3. Rip only workpieces longer than the diameter of the blade. Do not rip workpieces that are shorter than the diameter of the blade being used.

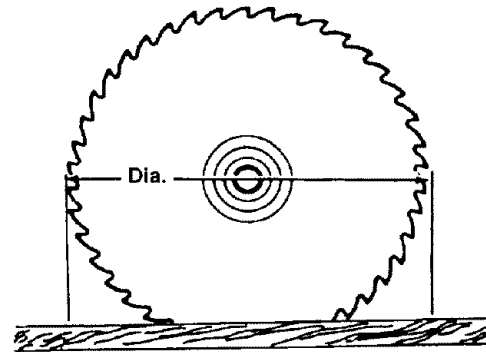

4. Workpieces that extend beyond the saw table can shift, twist, rise up from the table, or fall as they are cut or afterwards. Support workpiece with table extensions the same height as the saw table.

5. To prevent tipping, support outer ends of extensions with sturdy legs or an outrigger.

6. Do not use another person to help support workpieces or to aid by pushing or pulling on workpieces, because these actions can cause kickback. Use table extensions.

7. Use clamps or vice to hold workpiece. It's safer than using your hands.

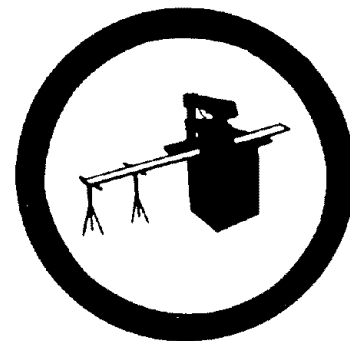

Blade Safety Instructions

1. Use only blades marked for at least 3450 rpm.
2. Use only 10" or smaller diameter blades.
3. Use blades for their recommended cutting procedures.
4. Keep blade sharp and clean.

5. Do not overtighten blade nut because blade collar could warp.

6. Do not turn saw on and off in rapid sequence because blade can loosen.

7. Blade should stop within 15 seconds after saw is switched off. If blade takes longer, the saw needs repair. Contact Sears Service Center.

Safety

On-Product Safety Labels

There are several safety labels on the saw. They alert the user to hazards explained in the manual and remind the user how to avoid the hazard.

At the **outfeed side, to the right of the guard** near the saw handle is this safety label to alert you to **wrong way feed**:

On the **infeed side of the guard** is this safety label to remind you to **lower the hold down to just clear the top of the work-piece for ripping**:

On the **rear of the yoke**, visible from the infeed side when the saw is in a rip position, is this safety label to alert you to **outfeed zone hazard**:

Note where they are located on the saw. Read and follow the safety information and instructions in these labels. Refer to the manual for detailed explanations and instructions.

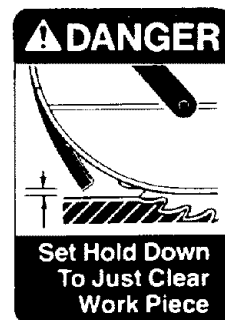
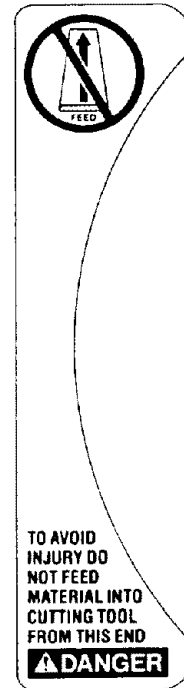

Near the saw handle is this safety label to alert you to **thrown objects** and to remind you to **wear safety goggles**:



On the **clear plastic guard** is this OSHA required label:

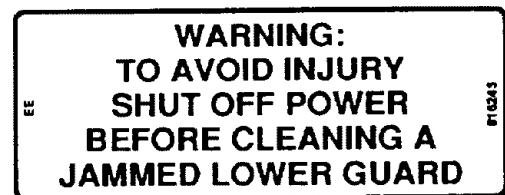

On the **bottom surface of the motor**, visible when the cutting tool is horizontal, is this safety label alerting you to **use a guard when edge molding**, and to **position the cutting tool behind the fence**:

(see Accessories Section)

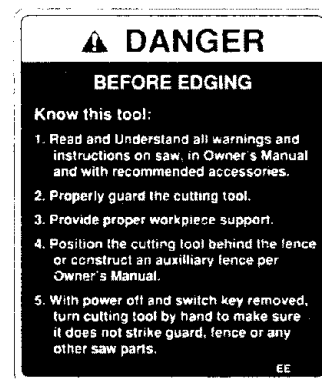

On the **front of the yoke** is this **general safety instruction label**:

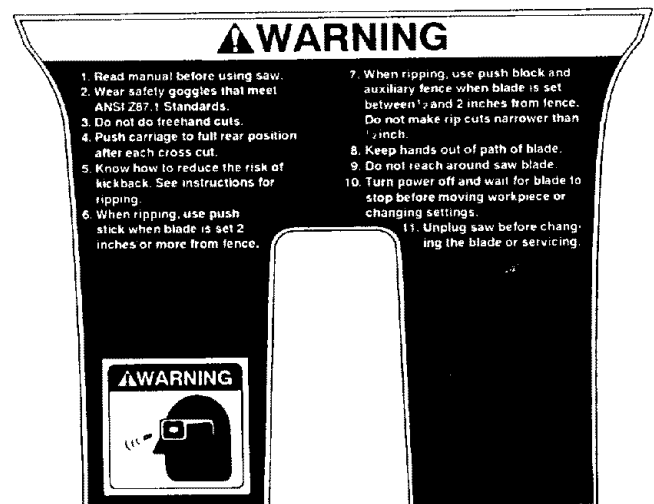

Assembly

Introduction

In order to get the most enjoyment out of your radial saw it is important that the machine be properly assembled, adjusted, and aligned. This procedure, although not difficult, takes time; perhaps eight hours or longer for the inexperienced user. However, after this initial set-up a weekly tune-up can be completed in approximately ten minutes by checking the alignment and only adjusting those settings which are incorrect.

Identify Parts

The following parts are included:

Note: Before beginning assembly, check that all parts are included. If you are missing any part, do not assemble the saw. Contact your Sears Service Center to get the missing part. Sometimes small parts can get lost in packaging material. Do not throw away any packaging until saw is put together. Check packaging for missing parts before contacting Sears. A complete parts list (Repair Parts) is at the end of the manual. Use the list to identify the number of the missing part.

This model includes:

- A. Basic Saw Assembly1
- B. Rear Table.....1
- C. Spacer Table1
- D. Fence (wooden).....1
- E. Front Table1
- F. Table Support2
- G. Loose Parts Bag(s)*
- H. Bag Containing
Accessory Guard1
- J. Leg.....4
- K. Stiffener, Side.....2
- L. Stiffener, Front/Rear.....2

* Number varies; bags can contain other smaller bags. **Note:** To make assembly easier keep contents of each bag together and separate from contents of other bags.

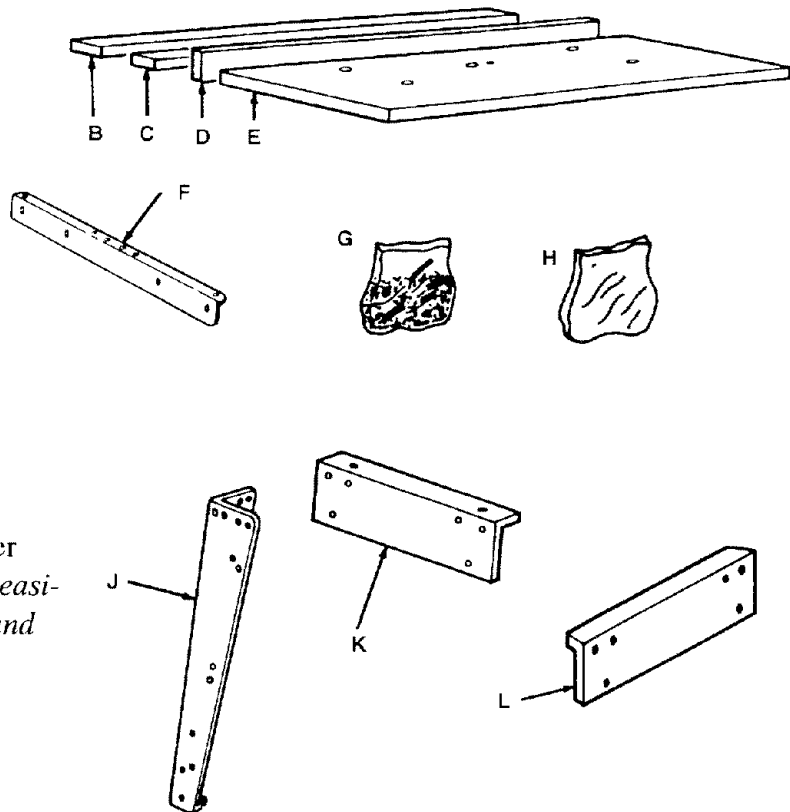
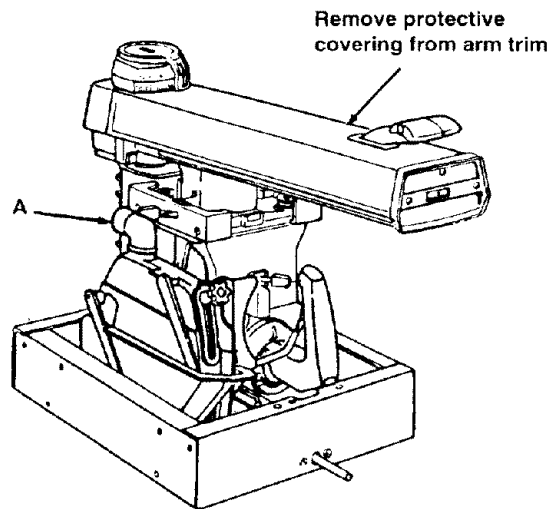

Assembly

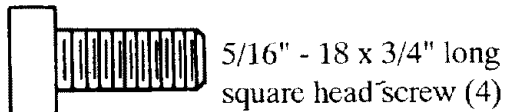

5/16" - 18 x 3/4" long square head screw (4)

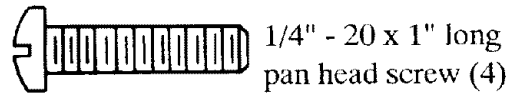

1/4" - 20 x 1" long pan head screw (4)

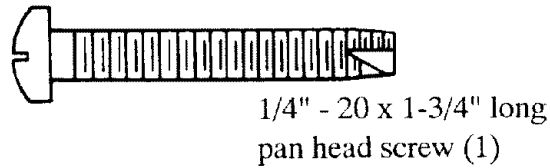

1/4" - 20 x 1-3/4" long pan head screw (1)

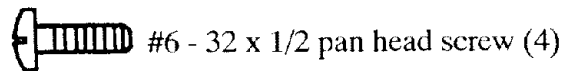

#6 - 32 x 1/2 pan head screw (4)

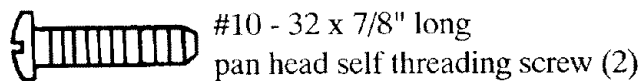

#10 - 32 x 7/8" long pan head self threading screw (2)

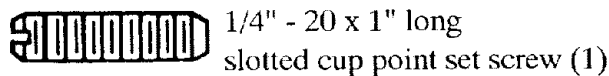

1/4" - 20 x 1" long slotted cup point set screw (1)

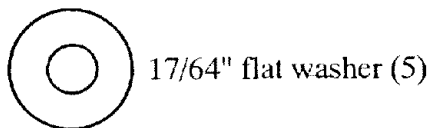

17/64" flat washer (5)

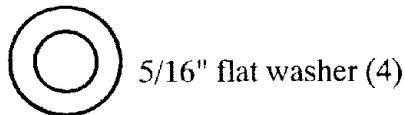

5/16" flat washer (4)

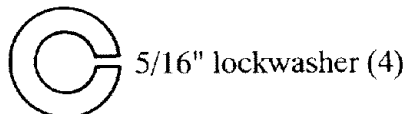

5/16" lockwasher (4)

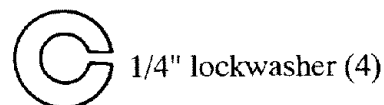

1/4" lockwasher (4)



tee nut (1)

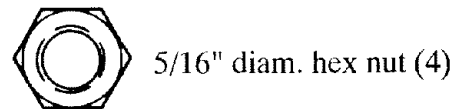

5/16" diam. hex nut (4)

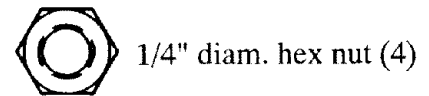

1/4" diam. hex nut (4)

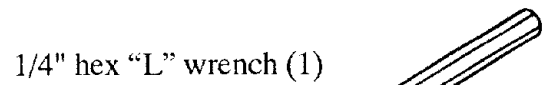

1/4" hex "L" wrench (1)

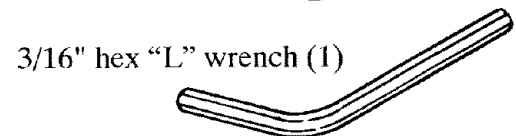

3/16" hex "L" wrench (1)



wrench (2)

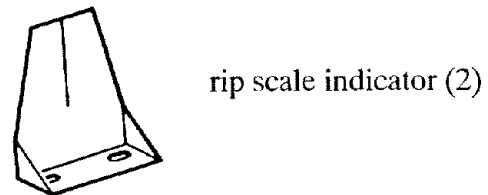

rip scale indicator (2)

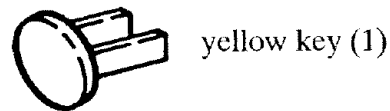

yellow key (1)

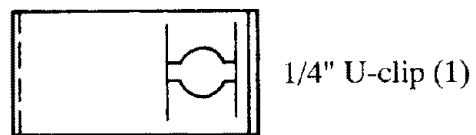

1/4" U-clip (1)



twin nut (2)

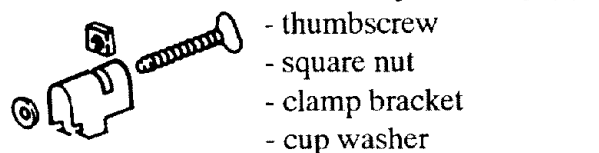

table clamp assembly (2)

- thumbscrew
- square nut
- clamp bracket
- cup washer

Assembly



crank

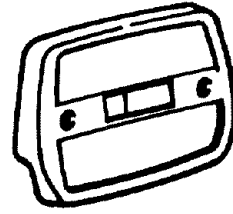

arm cap



1/4" diam. x 5/8" long
truss head screw (24)



1/4" external tooth
lockwasher (24)

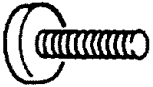

leveling foot (4)



5/16" diam. external
lockwasher (4)



3/8" diam. hex nut (8)

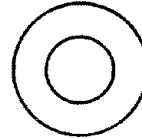

11/32" x 11/16" x 1/16"
washer (8)



5/16" diam. hex nut
(4)

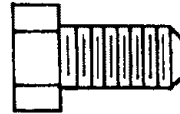

5/16" diam. x 5/8" long
hex head screw (4)



1/4" diam. hex nut
(24)

Tools needed for Assembly and Alignment



7/16-inch wrench



1/2-inch wrench



9/16-inch wrench



5/8-inch wrench



15/16-inch wrench

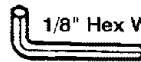

1/8" Hex Wrench

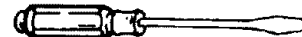

Medium Screwdriver



Pliers

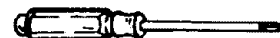

Phillips Screwdriver

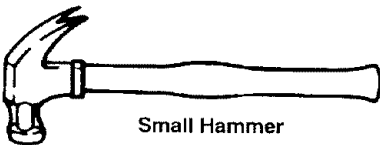

Small Hammer

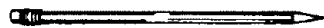

Pencil

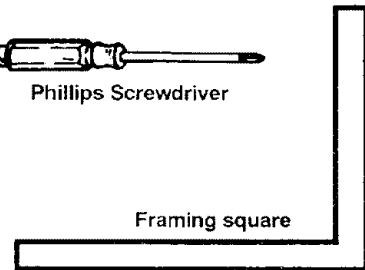

Framing square

Assembly

WARNING

Plugging in saw during assembly could result in electrical shock, or severe cuts from contact with spinning blade.

Do not plug in saw at any time during assembly.

Plug in saw only when it is to be used.

Assembly Steps

It is important for your safety and to get accurate cuts that you put the saw together according to these instructions.

Follow these steps **in order**:

Assembling steel legs

For easy assembly it is recommended to finger tighten all screws, lockwashers, and hex nuts until the legset is fully assembled. Then go back and tighten all nuts securely.

From among the loose parts, find the following Hardware:

24 Truss Head Screws, 1/4-20 x 5/8

24 Lockwashers, 1/4-External

24 Hex Nuts, 1/4-20

8 Hex Nuts, 3/8 - 16

4 Leveling Feet

1. Insert three truss head screws through the three holes near the top of one Leg. Place the Side Stiffener up to the Leg, as shown, so that the three screws line up with the holes in the Side Stiffeners marked with an "X" in the illustration.
2. Place a lockwasher and hex nut on each screw and finger tighten the hex nut.
3. Following the same procedure as above, continue to fasten together the remaining Legs, Side Stiffeners, and Front/Rear Stiffeners as illustrated.
4. Set stand upright and securely tighten all nuts.

5. Install one 3/8-16 hex nut completely onto each of the leveling feet. Insert one leveling foot through hole in bottom of each leg and install a 3/8-16 hex nut.

6. To level steel legs, loosen nut on inside of leg and turn nut on outside to raise or lower feet. Adjust all four levelers if necessary, and then tighten nuts on inside of leg.

Note: These levelers are not intended for height adjustment.

X = Location of Truss Head Screws

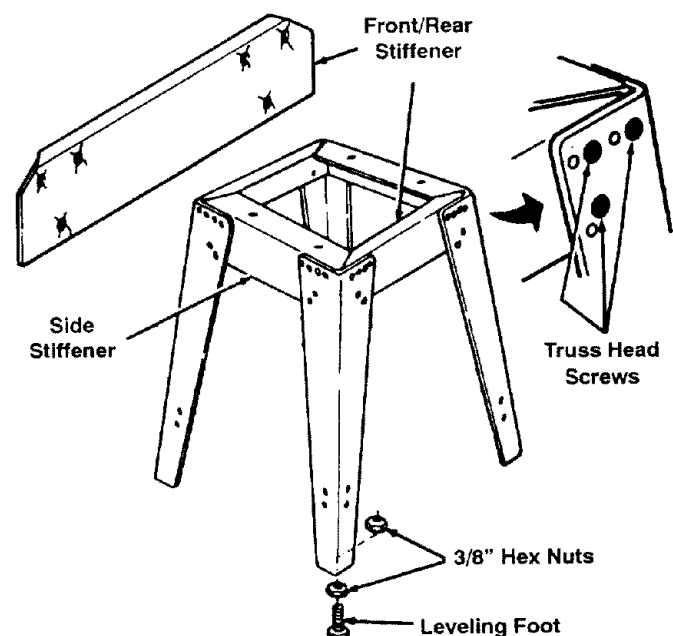

Assembly

Mounting Saw

1. From among the loose parts, find the following hardware:

- 4 Hex Head Screws, 5/16-18 x 5/8
- 4 Lockwasher, 5/16 in. External Type
- 8 Washers, 11/32 ID
- 4 Hex Jam Nuts, 5/16-18

2. Place saw on legs so that holes in bottom of saw line up with holes marked X in top of legs.

3. Install screws, washers and nuts as shown.

If you mount the saw on any other Craftsman base or flat bench, make sure Elevation Crank has proper clearance to rotate. The saw must be bolted down. Position saw to slope slightly rearward, so when the carriage is installed it will not roll forward due to gravity.

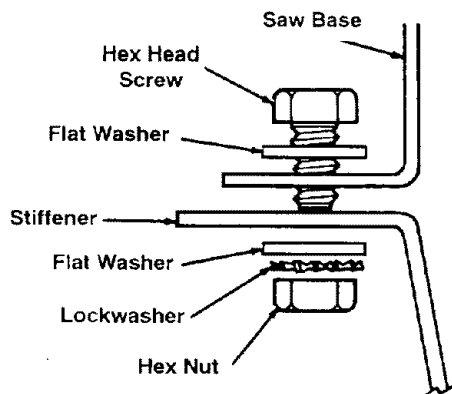

Attach Elevation Crank.

Install crank on elevation shaft. Be sure setscrew is tightened on flat of shaft.

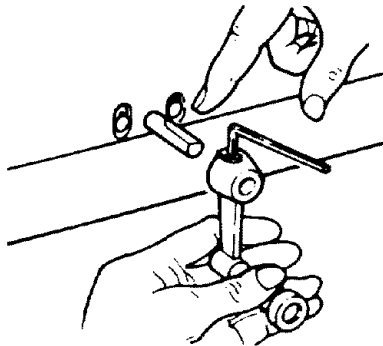

Elevate arm approximately 3 to 4 inches.

Remove shipping block and discard.

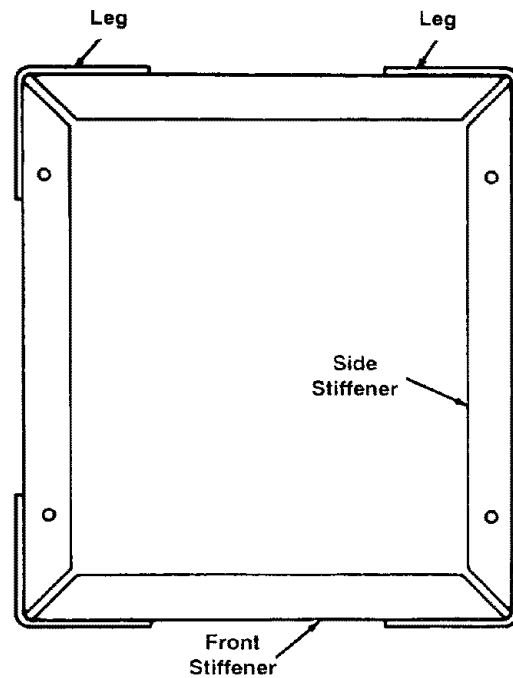

⚠ WARNING

Saw must slant slightly towards rear to keep blade carriage from rolling forward. Workpiece or saw can move unexpectedly if leg set rocks. Fingers, hand or arm could be cut off by blade contact. Adjust leveling feet before using saw.

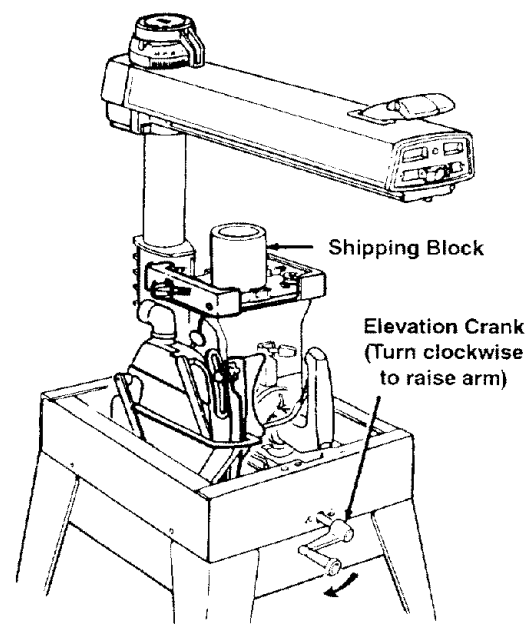

Assembly

Attaching Carriage - Motor to Arm

Remove carriage stop screw, lockwasher and tag. Read and understand warning tag before discarding.

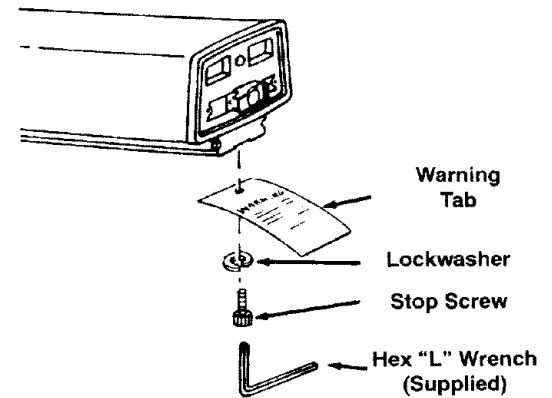

Lock miter/arm lock before proceeding.

Holding carriage assembly with both hands, carefully start and slide the carriage onto the tracks. The assembly must be held parallel with the arm so that all four bearings slide smoothly onto the arm, preventing any excessive strain on bearings and track.

▲ WARNING

Reinstall carriage stop screw and lockwasher to prevent carriage from rolling off arm.

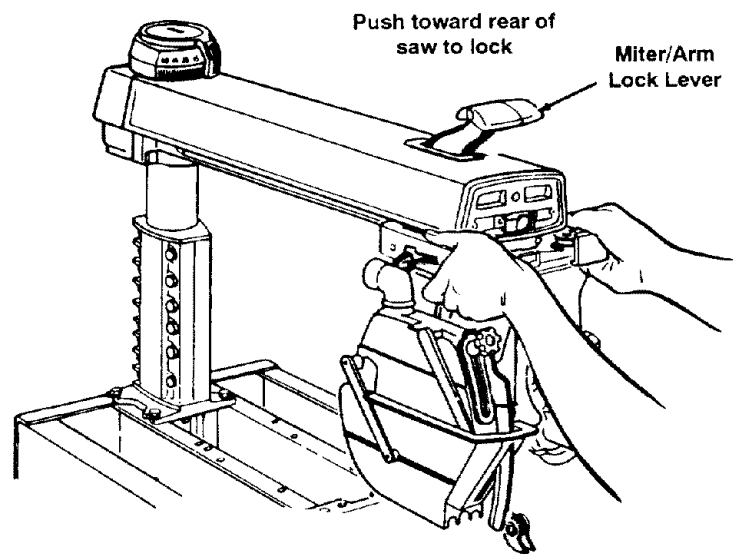

Remove two (2) motor packing studs that are threaded into bottom of motor.

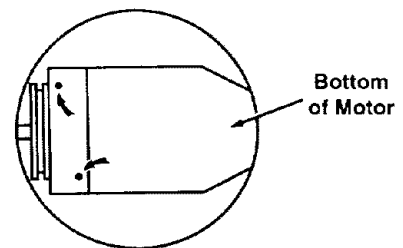

Install arm cap and arm cap trim

▲ WARNING

Make certain power cord is unplugged.

1. Insert finger under left end of switch lever and pull out to the "ON" position.
2. Place arm cap in position and install with (2) 10-32 x 7/8 self threading screws.
3. Push switch to "OFF" position.

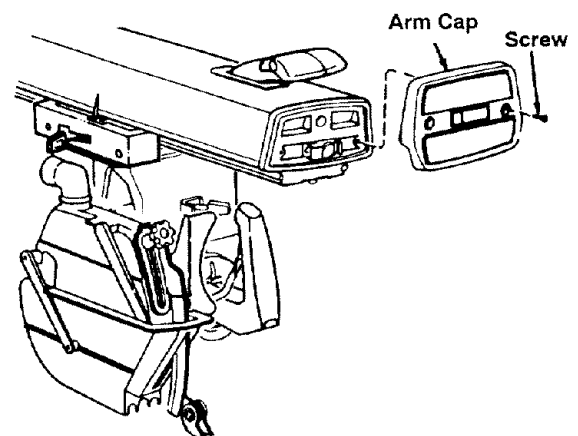

Assembly

Remove saw blade.

1. Tighten carriage lock knob, located on right side of arm.
2. Loosen guard clamp screw approximately 4 turns.
3. Use one hand to lift the clear plastic guard at the front of the saw.
4. Use the other hand to grasp the rear of the guard (below the dust elbow).
5. Rotate the entire guard assembly forward approximately 45° .
6. Remove the guard assembly.
7. Motor shaft has left hand threads. Hold shaft wrench and rotate arbor wrench down (clockwise).
8. Remove shaft nut, outer collar, saw blade, and inner collar. Set aside and out of the way.

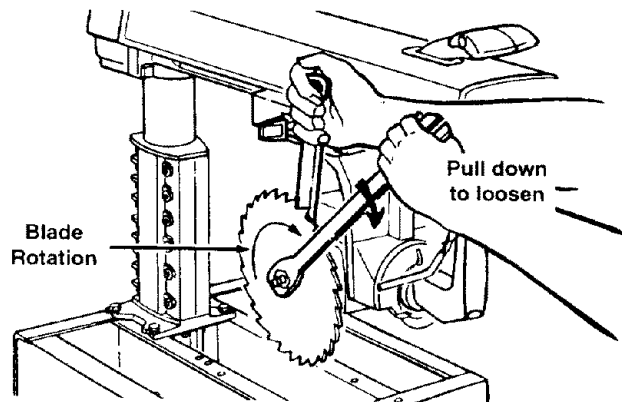

Attach Table Supports

1. Set out:
 - two table supports
 - four $5/16"$ $18 \times 3/4"$ long square head screws
 - four $11/32" \times 7/8" \times 1/16"$ flatwashers
 - four $5/16"$ lockwashers
 - four $5/16"$ hex nuts
2. Attach supports to side frame, making sure to use correct holes in table supports and side frame: Use two screws per support (insert screws through base and then support); on end of each screw put a flat washer, lockwasher and nut then finger tighten so table supports rest in lowest position.

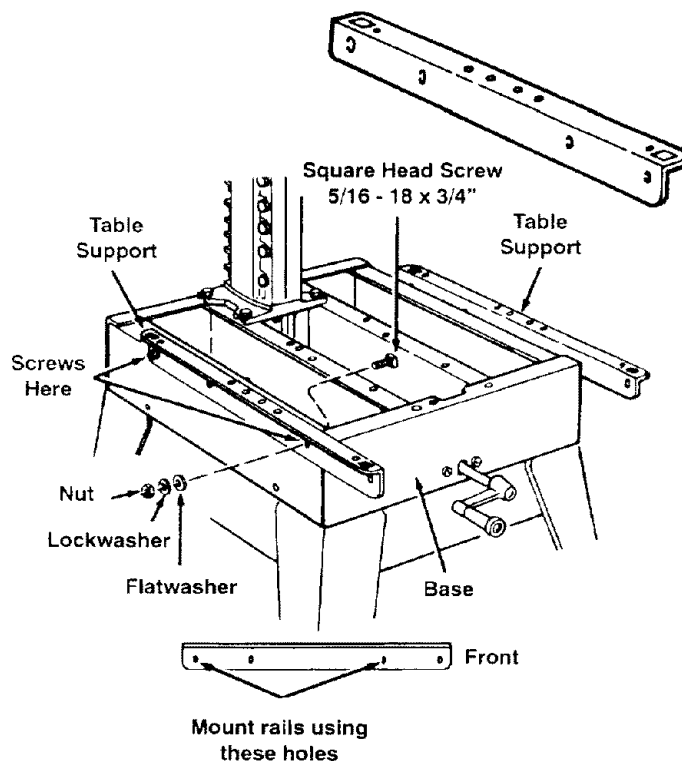

This concludes the assembly section. Except for installing table boards, fence, and table clamps the saw should be completely assembled. The next section deals with adjusting your saw to remove all "looseness" in order to get accurate cuts.

Adjustments

Arm Lock Adjusting Wheel

With the arm at an “unindexed” position and the miter lock applied, the locking action should feel tight and secure.

Considerable effort should be required to move the arm back towards 0°. It is always possible to force the arm because of the leverage advantage the long arm provides. However, the arm should resist moving when a reasonable amount of force is applied.

To check follow these steps:

1. Pull miter/arm lock forward to unlock and rotate arm to approximately 30° left or right.
2. Lock miter/arm lock by pushing handle toward rear of saw.
3. Apply pressure as shown above.
4. If the arm moves easily:
 - a. Unlock miter lock.
 - b. Locate the adjusting wheel as shown.
 - c. Turn wheel clockwise to tighten, counterclockwise to loosen.
5. Repeat steps 1, 2, 3 above and readjust as necessary.

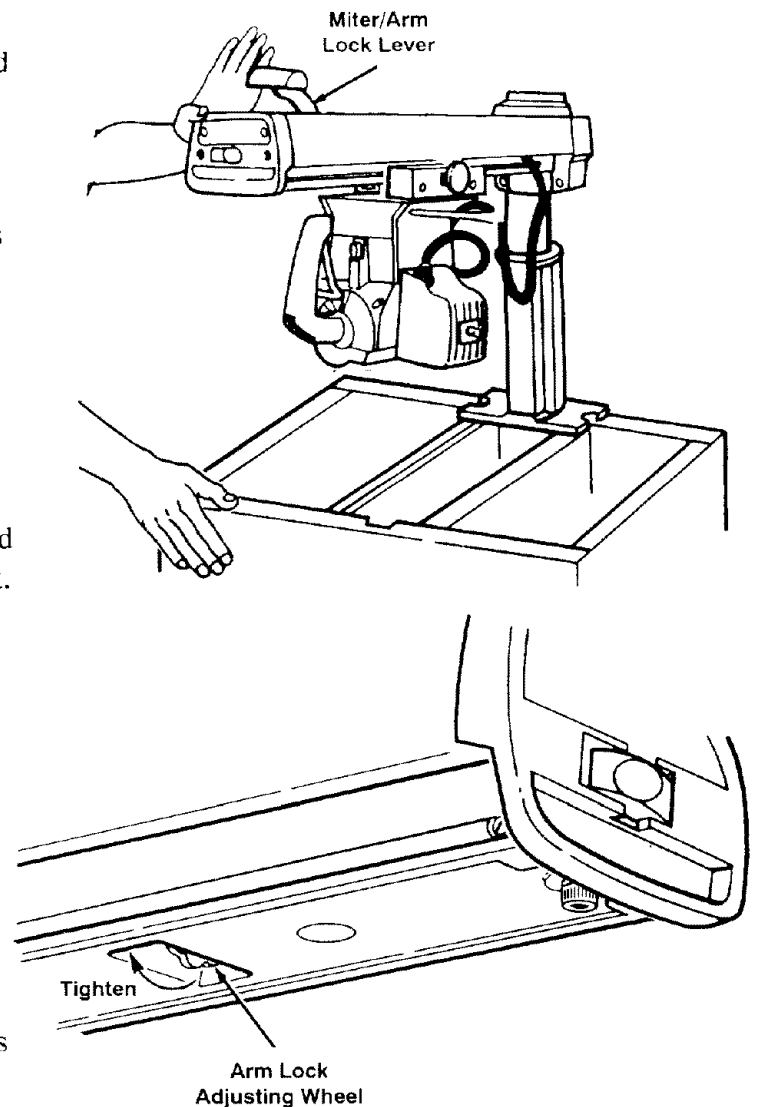

Adjustments

Yoke Clamp Adjustment

To check the yoke clamp adjustment follow these steps:

1. Pull the yoke lock handle towards the front of saw to unlock yoke. Pull forward on the yoke index lever (on the left side of carriage) to disengage index pin.
2. Swivel the motor halfway between the crosscutting and rip position so the index pin is not engaged.
3. Lock the yoke lock handle.
4. Grasp the motor with both hands and try to swivel it back into the crosscut position. It should not move.
5. If it does move follow these steps:
 - a. Remove arm cap.
 - b. Remove carriage stop screw and lock-washer with a 1/4 inch hex-L wrench.
 - c. Grasp the carriage assembly, move it carefully off the end of radial arm, holding it parallel to the radial arm until all carriage bearings are free of their tracks.
 - d. Rest the motor and carriage assembly on saw frame.
 - e. Set yoke lock handle at unlocked position. Tighten nut with 15/16" wrench, until lock handle locks mid-way between the two legs of the yoke.
 - f. Hold the motor and carriage assembly parallel to radial arm and start the rear bearings onto the tracks. Continue to hold the assembly parallel to the tracks until the forward bearings are on the tracks.
 - g. Slide the carriage rearward on the radial arm and install the carriage stop screw and lockwasher.
 - h. Install arm cap.
 - i. Repeat steps 1-4. Readjust if necessary.

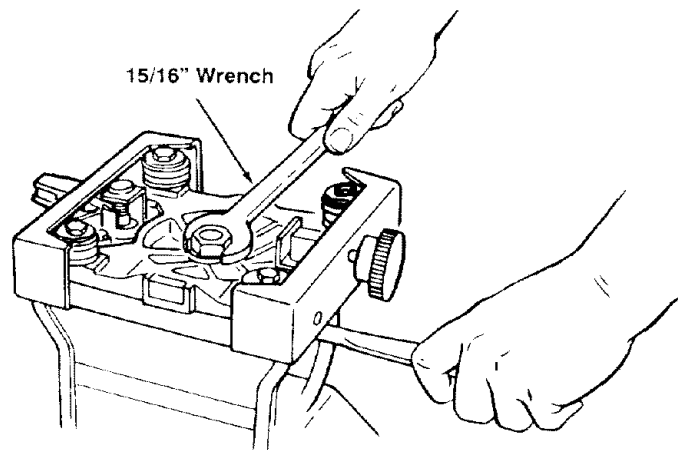
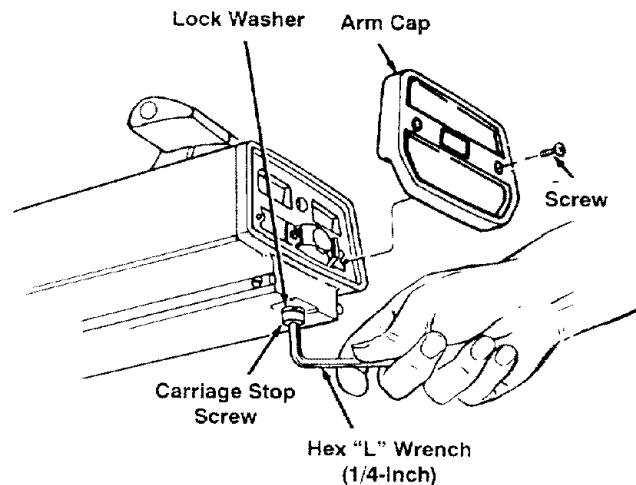
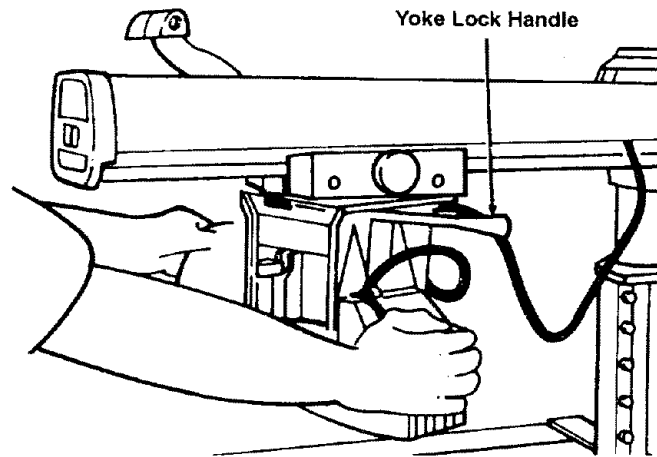

Adjustments

Bevel Lock Lever

The purpose of the bevel lock lever is to lock the motor at any angle. To check follow these steps:

1. Unlock the bevel lock lever. Move the bevel index pin to the left and rotate the saw to approximately 30°. Lock the bevel lock lever.
2. Use both hands as shown and try to force the motor out of position. If the motor moves, the bevel lock lever needs to be tightened. On the other hand if it is extremely hard to lock the bevel lock lever it has been over-tightened.
3. Follow these steps to adjust:
 - a. Remove the socket set screw with hex wrench as shown.
 - b. Use the bevel lock lever as a wrench to tighten or loosen the clamp bolt. Do not over tighten.
 - c. Repeat steps 1 and 2. Re-adjust if necessary
 - d. Replace bevel lock lever in the locked position.
 - e. Tighten the set screw.

Note: The clamp bolt has a left handed thread. Therefore, to increase the clamping effect, rotate the bevel lock lever – when used as a wrench – from right to left, or clockwise when viewed from above. If you accidentally rotate it the wrong way and disengage the bolt from the matching steel nut, it will be necessary to remove the Yoke Handle, and Bevel Scale, in order to reinstall the bolt into the nut.

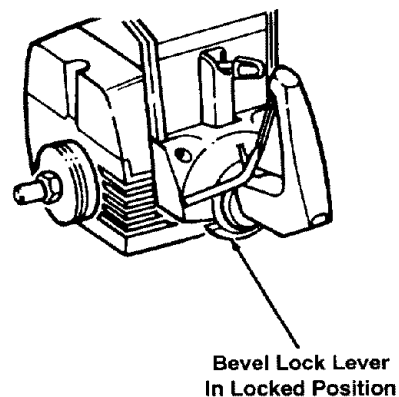
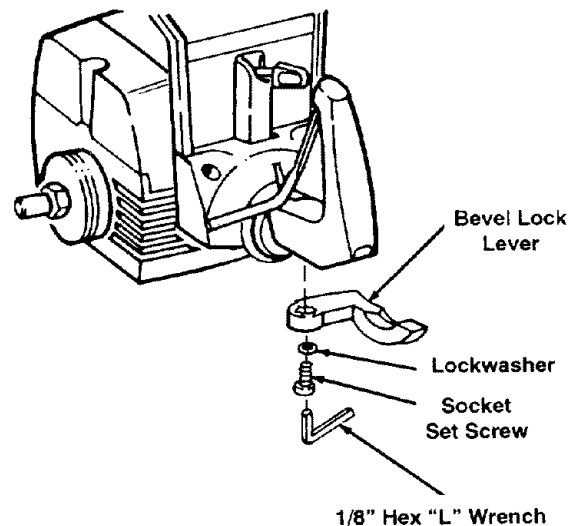
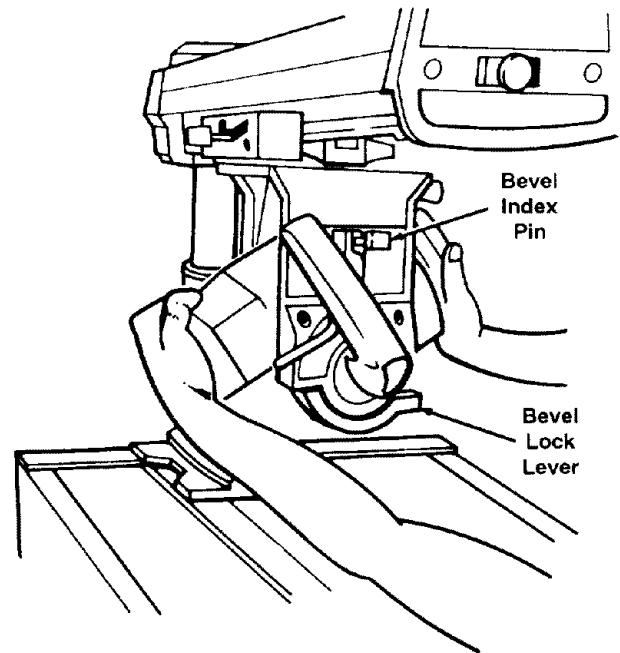

Adjustments

Arm to Column Adjustment

If you can move the end of the radial arm up and down when the arm is unlocked, adjust as directed below:

- a. Remove two (2) screws from rear cover plate. Tighten evenly top two 3/8-16 bolts until arm moves firmly. There should be no vertical or horizontal movement in the arm when miter/arm lock is locked and unlocked.
- b. Bottom two nuts should be snugged evenly, but not nearly as tight as top two bolts.
- c. Re-Install Rear Cover Plate.

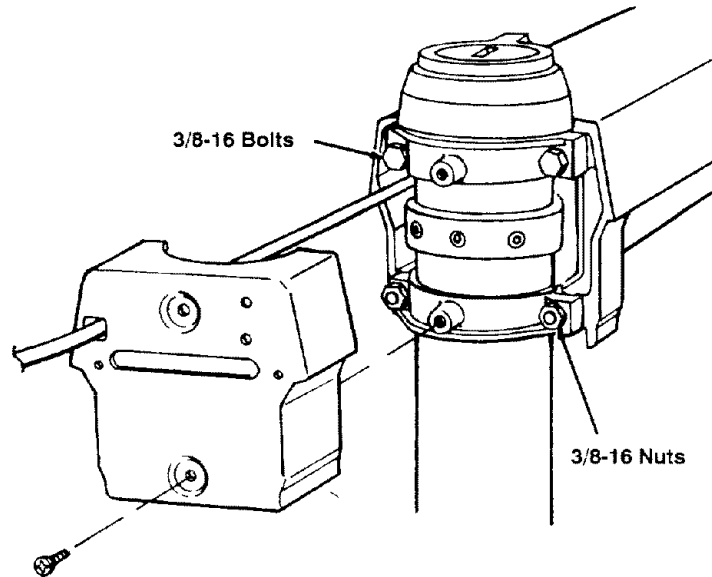

Adjusting Column Tube in Column Support

This adjustment will remove any looseness between the column tube and column support while serving two purposes:

- To insure accurate cuts; and
- To allow the column tube to raise and lower smoothly.

Note: *The following adjustment is very critical. All future alignment procedures rely on this adjustment being performed correctly. All looseness must be removed.*

This section is set up in two sections:
Alignment checks and adjustments.

It is very important that the column tube and the inside of the column support are coated with a film of uncontaminated lubricant.

Alignment Checks

Two checks are required, these are adjusted at the factory, but may have shifted out of alignment during shipment.

1. Index and lock arm at 0° Miter.
2. Vertical Alignment Check:

The column support needs to be compressed using the black and silver screws so that it properly controls the movements of the column tube. Precise alignment is done only by the bright plated 5/16-18 screws.

With your left elbow resting on the base under the front of radial arm, push up slightly on the arm. Look for a noticeable movement between the column tube and the column support.

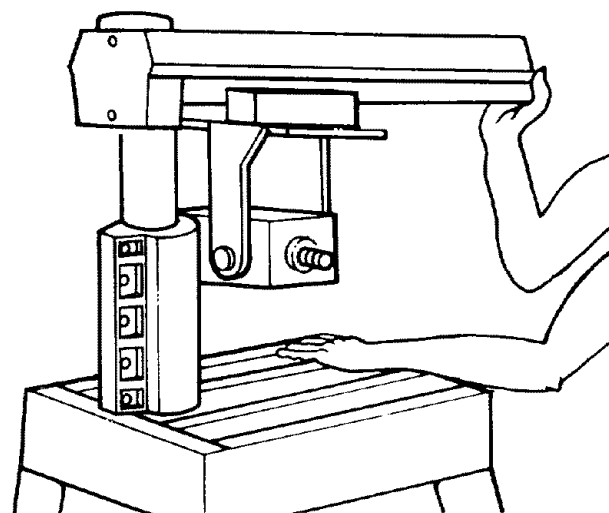

Adjustments

3. Rotational Alignment Check:

While holding the arm with one hand, hold fingers of other hand as shown, between column tube and column support. Apply gentle side-to-side pressure at end of arm. Any side-to-side or rotational movement can be felt with finger at arrow location.

Alignment Adjustments

1. Loosen (2) 1/4 - 20 Gib socket cap screws on the left side at the rear of the column support slightly (1/2 turn).

Note: *If Vertical Alignment was OK and adjustment is not needed, proceed to step 6.*

2. Vertical Adjustment:

Using the closed end of a box wrench, tighten all of the 5/16-18 black screw heads on the column support casting 1/16th to 1/8th of a turn. Tighten the (2) 5/16-18 silver screw heads slightly more than the black ones to achieve a close fit to the column tube. (A 1/4" drive ratchet with a six point socket may be needed to get enough torque on bolts.)

3. Elevate and then lower the Arm using the elevation crank.

4. If the column tube binds and elevation is difficult, go back to step 2 and loosen the screws until you achieve smooth but firm elevation, recheck step 3.

5. Redo "Vertical Alignment Check".

- a. If vertical misalignment still exists, repeat steps 2 through 4.
- b. If vertical misalignment no longer exists, and you have achieved smooth but firm elevation, proceed to step 6.

6. Rotational Adjustment:

Tighten the (2) 1/4-20 Gib socket cap screws until no noticeable rotational play exists as in "Rotational Alignment Check".

7. Redo "Rotational Alignment Check"

- a. If rotational misalignment still exists, repeat step 6.
- b. If rotational misalignment no longer exists, and you have achieved smooth but firm elevation, this alignment procedure is complete.

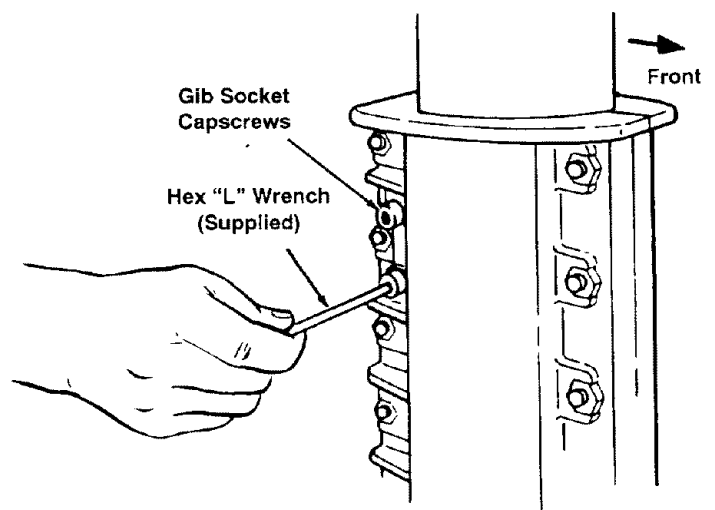
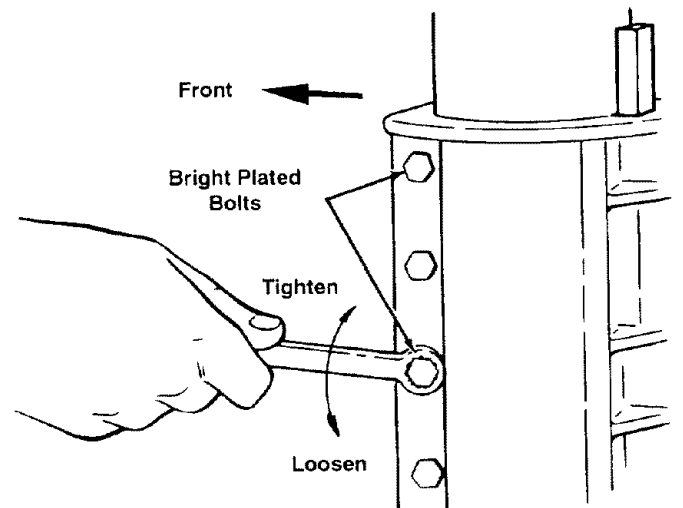
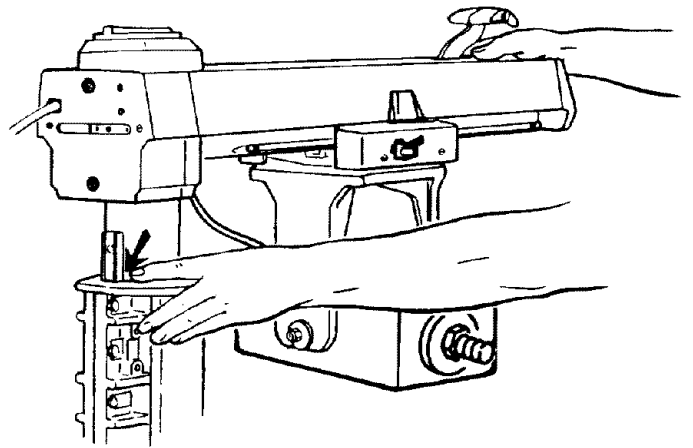

Adjustments

Adjusting Carriage Bearings

If the carriage bearings are loose it not only allows the saw blade to move up, down, and sideways but also results in inaccurate cuts. Before following these steps make sure the tracks (steel rods) and carriage bearings have been cleaned by wiping them with a clean cloth.

When properly adjusted, the top and bottom face of all four bearing grooves should be in contact with the arm tracks for their entire length and carriage should roll smoothly with some resistance.

To test for looseness between bearings and tracks on radial arm, perform the following steps.

1. Remove left-hand carriage cover. (2 screws)
2. Push the carriage to its full rearward position.
3. Grasp front carriage bearing as shown and hold as tight as possible. At the same time pull carriage forward. If you can stop the bearing from turning, it requires adjusting.
4. Check rear bearing in the same manner.
5. Adjust as follows:
 - a. Use two 1/2" wrenches to loosen nut just enough to permit the eccentric screw to turn.
 - b. Rotate the eccentric screw a partial turn (left or right) as required to take up looseness.
 - c. Hold the head of eccentric screw in the position established in the preceding step and tighten nut on underside of carriage. Correct adjustment exists when you cannot keep the bearings from turning. However, excessive bearing pressure will cause difficult operation and rapid wear.
 - d. Install carriage cover.

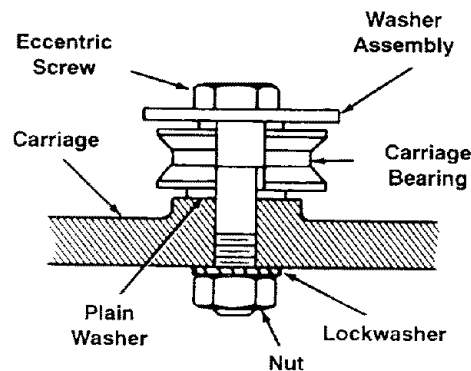
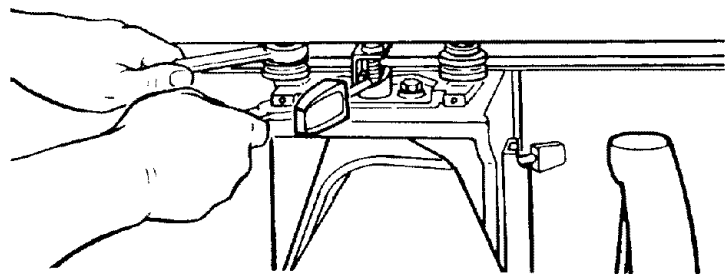
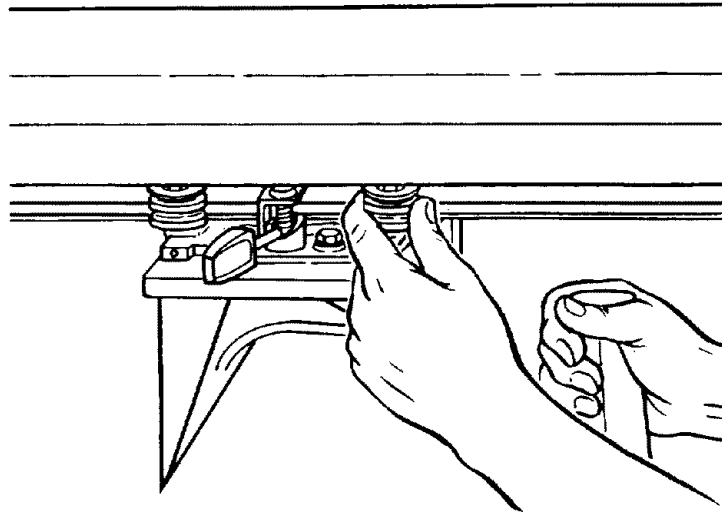

Left Side Carriage Bearings

Adjustments

Positioning Table Supports/Installing Front Table/Leveling Front Table

Note: The goal in adjusting the table supports and leveling the front table is to make sure that the table is the same distance from the radial arm at all points. This ensures that when the table and blade are installed the clearance between them will be equal at all points.

Positioning Table Supports

1. Release bevel lock lever, move bevel index lever to the left and rotate the motor to position arbor shaft down. Lock bevel lock.
2. Unlock and hold miter/arm lock lever in index release position as shown. Position arm against left stop (approximately 50° miter). Loosen carriage lock knob and position arbor shaft directly over left hand channel.

Note: For safety reasons in accordance with the UL standard, stops have been provided to prevent 360° rotation of the radial arm.

3. Slide the arbor wrench handle between end of motor shaft and table support to act as a feeler gauge. Carefully lower the motor with elevation crank until the end of shaft is just touching the arbor wrench. The wrench should slide back and forth with only slight resistance. Tighten screw "A".

Note: Do not change this elevation setting until both left and right hand table support channels have been adjusted.

4. Move arm and carriage to screw "B". Adjust position of table support so that the arbor wrench just slips between the end of the motor shaft and the support. Tighten screw "B".
5. Move arm and carriage to right hand table support and level in the same manner as in step 4.
6. Recheck both support channels to make sure that tightening screws did not affect the accuracy of the adjustment.
7. Elevate saw and return motor to horizontal position to provide clearance for installation of front work table.

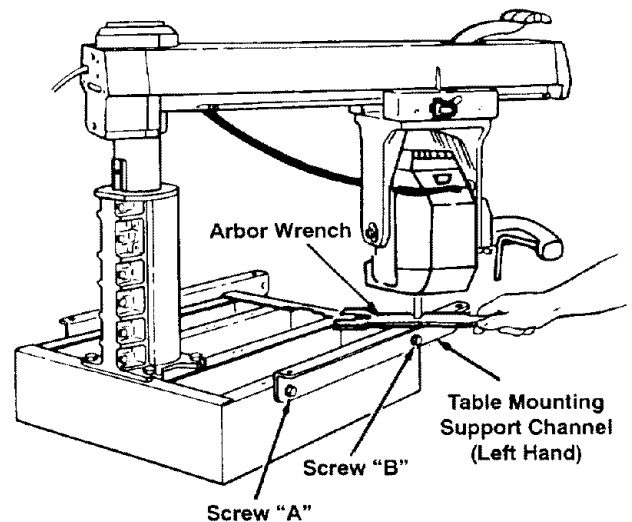
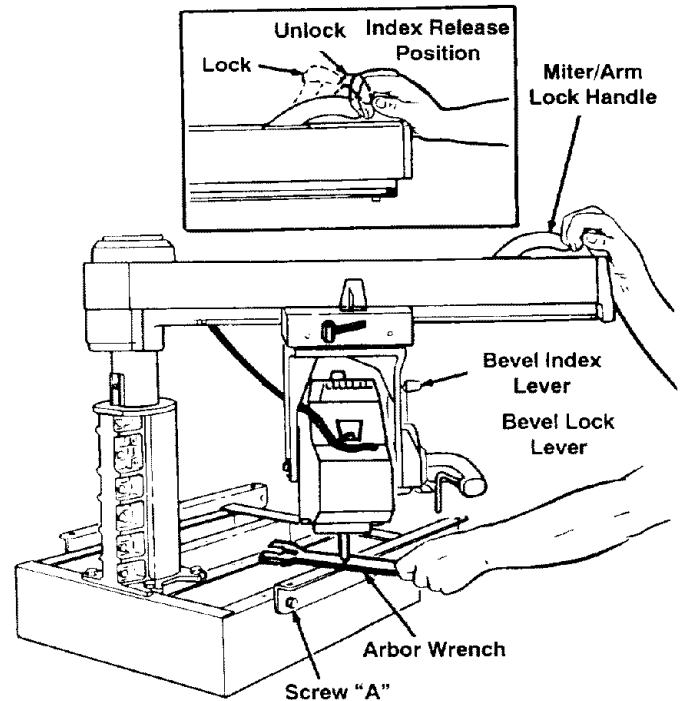

Adjustments

Installing Front Table

1. Set out:

- front table
- tee nut
- 1/4" U-clip
- 1/4" diam. x 7/8" long cup point set screw
- four 1/4" diam x 1" long pan head screws
- 1/4" diam. x 1-3/4" long pan head screw
- five 17/64" I.D. x 5/8" O.D. flat washers
- four 1/4" lock washers
- four 1/4" diam. hex nuts.

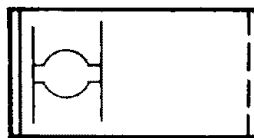

2. Identify top and bottom of table: top has counterbored holes. Place table **bottom side up** on solid surface. Hammer tee nut into leveling hole. (This hole is not counter-bored from the top).

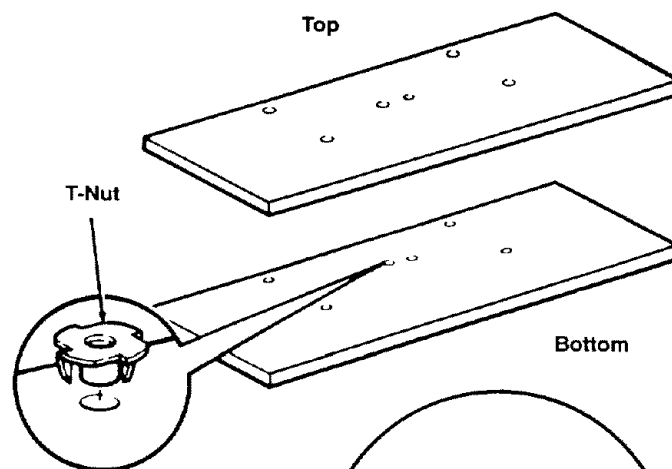

3. Snap U-clip onto front edge of base so hole lines up with hole just to the left of center notch.

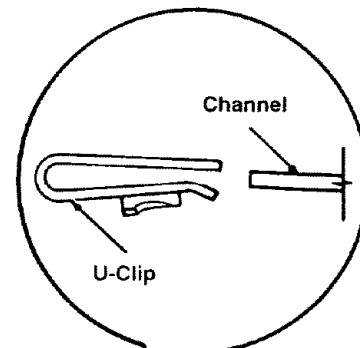

4. Place table, **top side up**, on saw so center counterbored hole lines up with hole in U-clip. **Note:** Table will extend over front edge of saw frame.

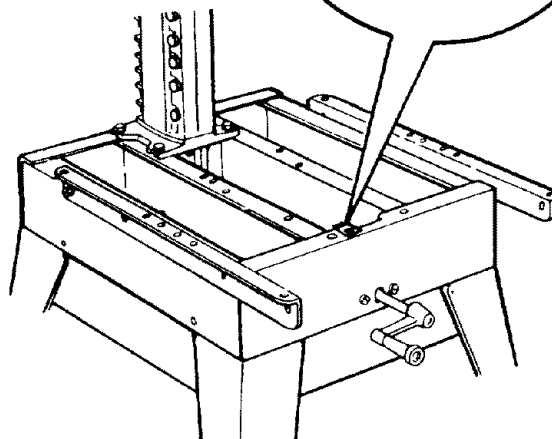

Adjustments

5. Drop a flat washer into each counter-bored hole.

6. Start 1-3/4" long pan head screw through center hole and into U-clip, but do not fully tighten.

7. Start cup point set screw through leveling hole and into tee nut, but do not fully tighten.

8. Put 1" long pan head screw in each of four remaining holes and through matching holes in table supports. On end of each screw, put lock washer then nut and tighten with screwdriver.

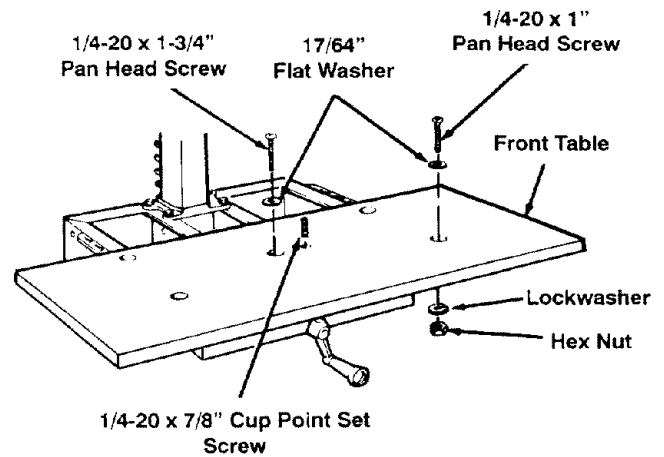

Make Front Table Flat

1. Place rear table on its edge, across center of front table. Check for gap between surfaces.

If there is less than 1/32" gap, tighten cup point set screw until it touches frame (look underneath table), then tighten center (1-3/4" long) pan head screw.

If there is more than 1/32" gap, close gap by raising or lowering center of front table:

to raise center, tighten cup point set screw against frame;

to lower center, tighten center (1-3/4" long) pan head screw.

2. When gap is closed, make sure cup point set screw touches frame (look underneath table), and center (1-3/4" long) pan head screw is tightened.

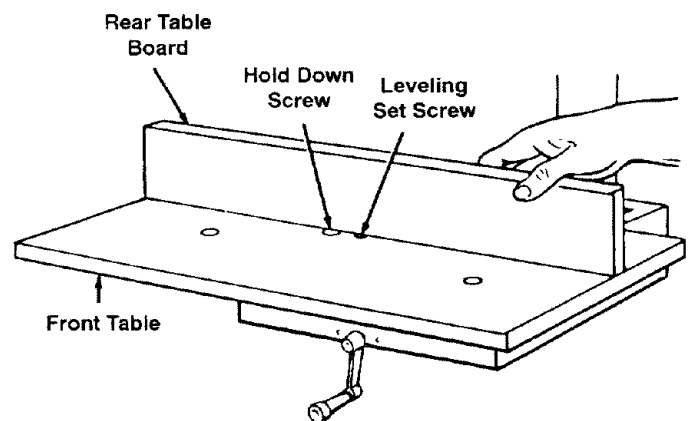

This concludes adjusting your saw where you have removed all "looseness" or slack between the different parts of the saw. The next section deals with actually aligning the sawblade to get accurate cuts.

Alignment

This section applies to all three models covered by this manual.

The saw and blade must be aligned correctly for two reasons:

- 1) to prevent binding of the blade and work-piece, which can cause jams, kickbacks, or thrown workpieces;
- 2) to make accurate cuts.

Alignment and Adjustment Steps

The following alignments and adjustments **must be made in order**. If you miss an adjustment, you must go back, make the missed adjustment, and repeat all steps from that point on.

These adjustments are like fine tuning a piece of equipment. Often, a series of steps must be repeated more than once in order to get the adjustment right. There are many adjustments to make. Because some adjustments may be awkward, you may want to ask someone to help you.

Before you start, make sure the framing square is true.

Square Crosscut Travel

The goal of this adjustment is to make accurate crosscuts. To do so, the radial arm must be square to the fence, otherwise, there will be a slight miter angle in all crosscuts.

Squaring cross cut travel.

1. Index but do not lock arm at 0° miter.
2. Install saw blade as shown. Motor shaft has left hand threads.

Note: Do not overtighten arbor nut. Use the arbor wrench to just “snug” it.

⚠ WARNING

Plugging in saw during alignment could result in accidental start-up and severe cuts from contact with spinning blade.

Do not plug in saw at anytime during alignment or adjustment. Plug in saw only when it is to be used.

Check Framing Square

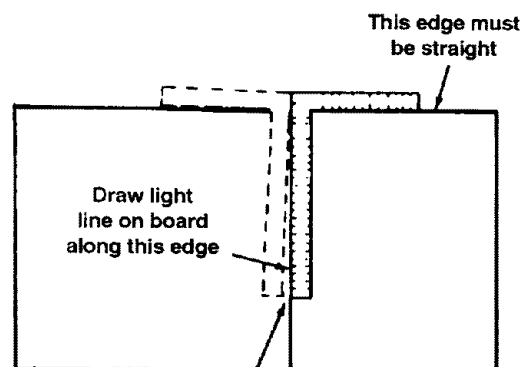

Should be no gap or overlap here when square is flipped over to dotted position.

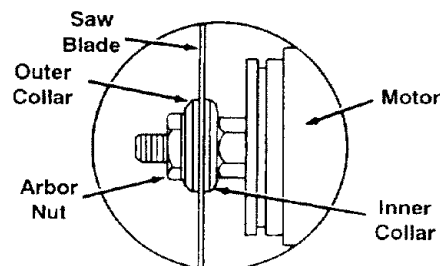
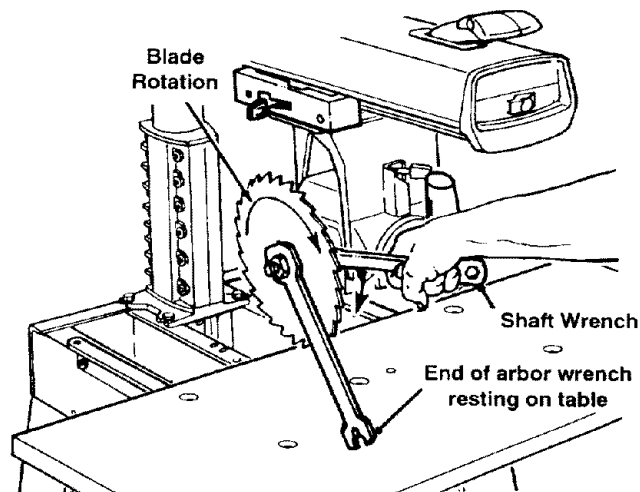

Alignment

3. Lower arm until saw blade just clears the front table. Lock the yoke lock handle and bevel lock lever.

4. Place a framing square on the table, as shown, with one leg of square firmly against rear edge of front table. Position the blade and square until the leg of the square just contacts a tooth of the blade. Mark this tooth.

5. When the carriage is moved slowly back and forth on the arm, the marked tooth should just touch the square at all points. If marked tooth moves into or away from square the following adjustments are required:

- a. Loosen (3) 3/8 – 16 set screws in arm latch at rear of arm.
- b. Move the arm in direction to make marked tooth follow edge of square when the saw blade is moved along arm in a “cross cut” manner.
- c. Lock miter/arm lock.
- d. Retighten (3) setscrews in arm latch as tight as possible and recheck “cross cut” travel.

Note: This squaring of the cross cut travel will simultaneously set both of the 45° miter index positions.

6. Set miter indicator on 0° position using end of blade wrench.

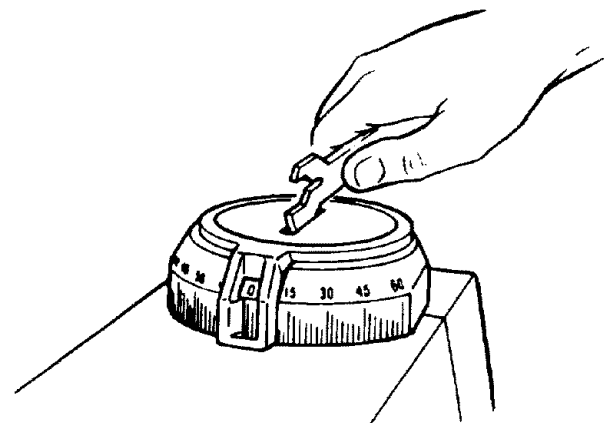
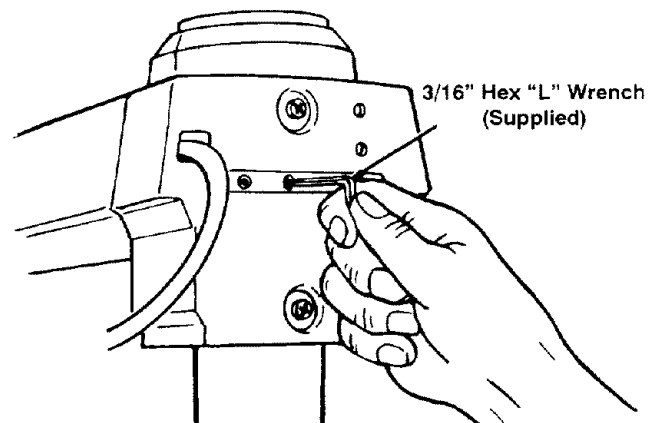
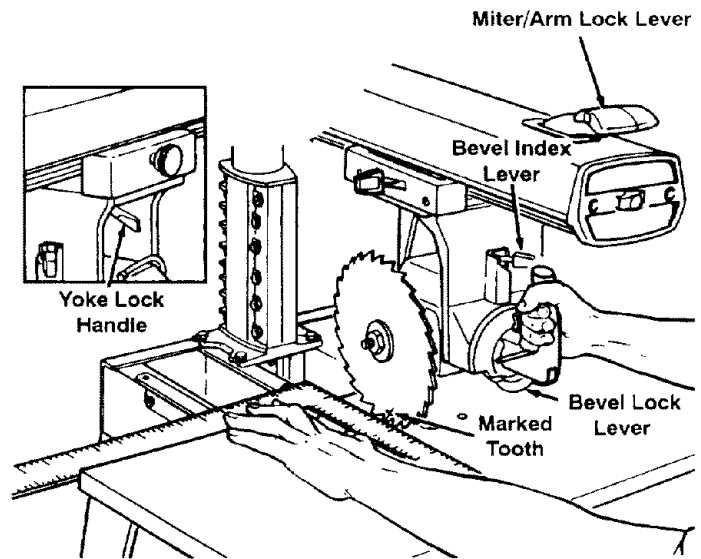

Alignment

Install Table Clamps

1. Insert fence, then spacer table, then rear table.

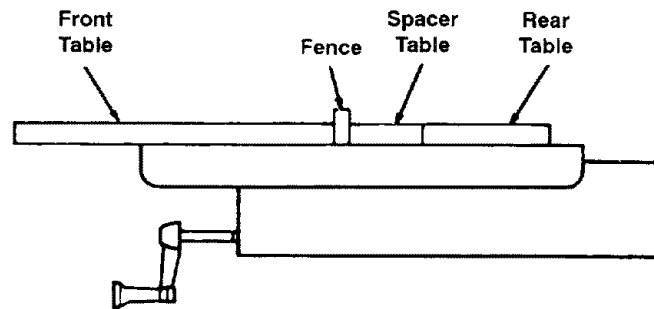

2. Set out two unassembled table clamps:

- two cup washers
- two clamp brackets
- two square nuts
- two thumbscrews

3. Slip square nut into slot at top of clamp bracket.

4. Insert thumbscrew through rear opening, and turn clockwise until it comes out other side about 1/2". **Note:** If you put screw in front opening, clamp will not work.

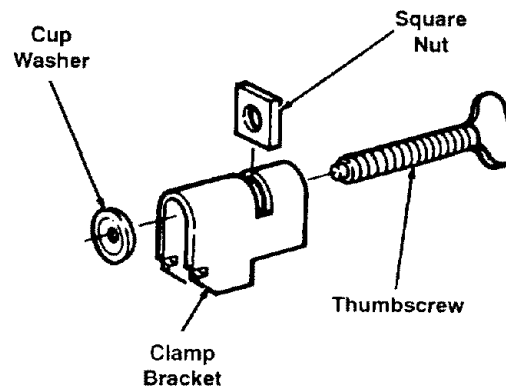

5. Tilt clamp bracket forward and snap into place in opening at rear of table support.

6. Hold cup washer with concave side against rear table. Turn thumbscrew clockwise until it snaps into washer.

7. Repeat steps for other table clamp.

8. Tighten thumbscrews to clamp table sections in place.

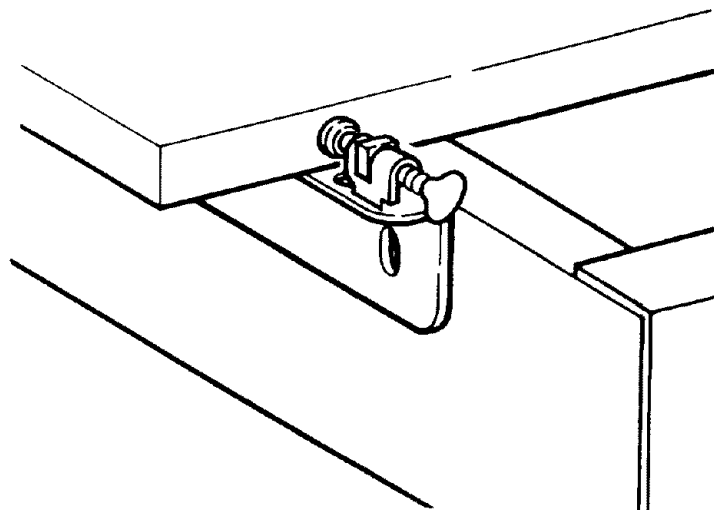

Square Blade to Table for Crosscutting

The goal of this adjustment is to make the blade square to the table so that crosscuts will be accurate; otherwise all crosscuts will have a slight bevel angle.

1. Lower blade until it just clears front table. Lock bevel, miter, rip, and yoke locks.
2. Place a framing square on the table with the short leg against the saw blade and long leg parallel to fence. Do not allow the square to rest against a "set-out" tooth; it must rest flat against the blade side.
3. If the saw blade is square with the table top (no visible gap appears between the saw blade and square) no adjustment is required. Set bevel indicator to 0° reading. If the square does not touch the saw blade as shown (with square leg held firmly against the table top), perform the following adjustments:

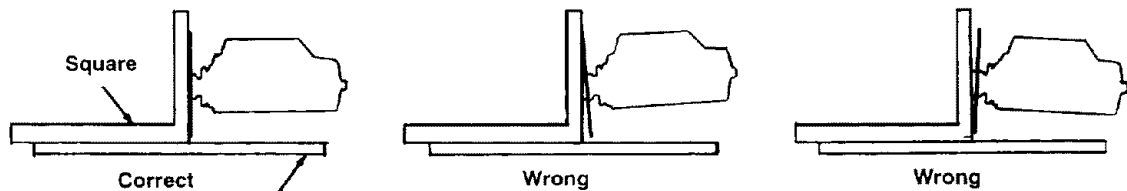
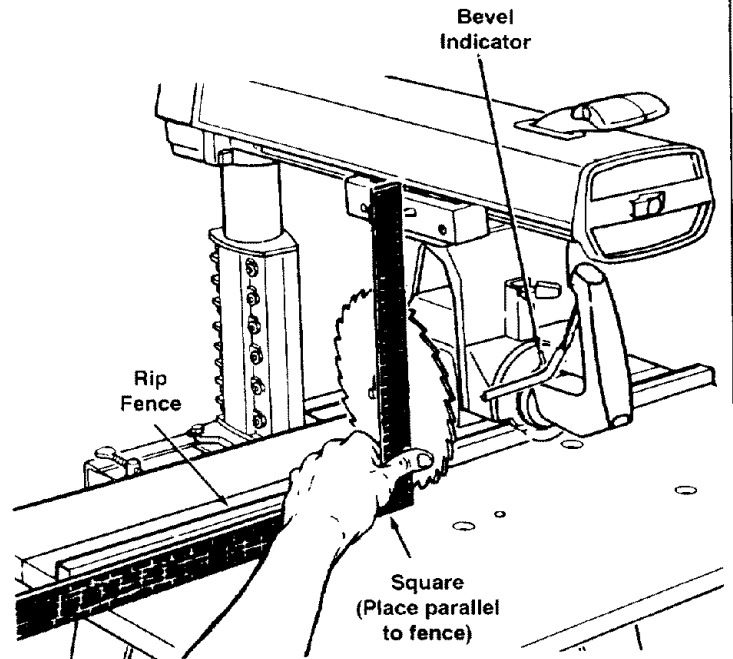

- a. Tighten rip lock knob.
- b. Remove handle by removing 5/16-18 socket head screw and lockwasher.
- c. Slightly loosen the four socket head screws with 1/4" Hex "L" Wrench. Rotate motor while holding square firmly against saw blade and table top.
- d. Slightly tighten each of the four screws and recheck... Now tighten each screw tight.
- e. Reinstall handle and adjust indicator to 0° reading.
- f. Loosen rip lock knob.

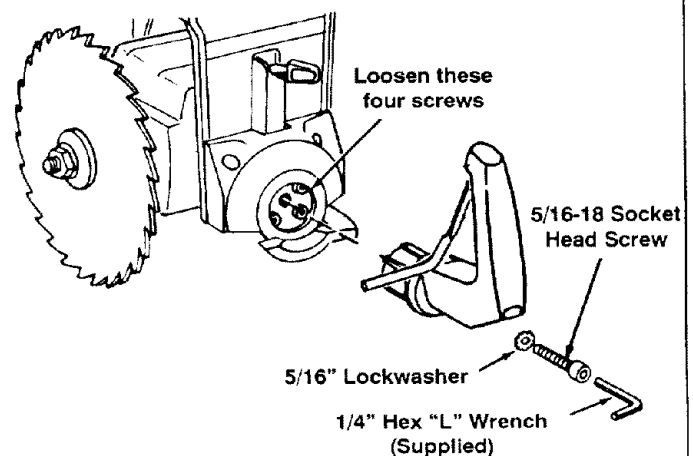

Alignment

Square Blade to Fence

The goal in setting the blade square to the fence is to reduce the risk of kickback when ripping. This adjustment will also reduce splintering of the workpiece and burning of the kerf during ripping and crosscutting.

1. Lower blade until it just clears table.
2. Unlock rip lock, Pull blade forward to front of arm. Lock rip lock.
3. Place square so short edge is against fence and long edge is against flat surface of blade (not on a tooth), just below blade collar.
4. There should be no gap between blade and square. **Note:** *Not all blades are perfectly flat. Check different points along blade surface by making quarter turns and looking for gap each time. Consider overall fit of blade. If there is no gap, no adjustment is needed.*
5. If there is a visible gap between the saw blade and square adjust as follows:
 - a. Remove left hand carriage cover.
 - b. Loosen the yoke lock handle. (on right side of carriage).
 - c. Loosen slightly the two hex-head screws holding yoke index pin.
 - d. Rotate the yoke assembly until gap between the saw blade and square is eliminated.
 - e. Lock yoke lock handle. Retighten the two hex-head screws.
 - f. Recheck blade squareness.
 - g. Install carriage cover.
 - h. Loosen carriage lock knob and return blade to rear of arm.

Note: *This alignment procedure will simultaneously set both yoke indexing positions for blade in and out rip.*

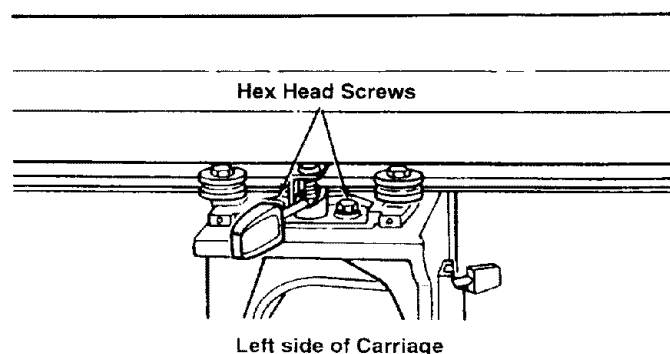
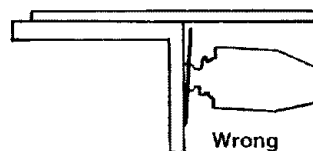
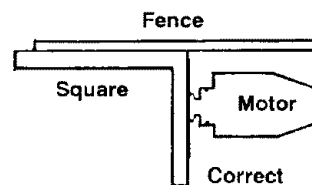
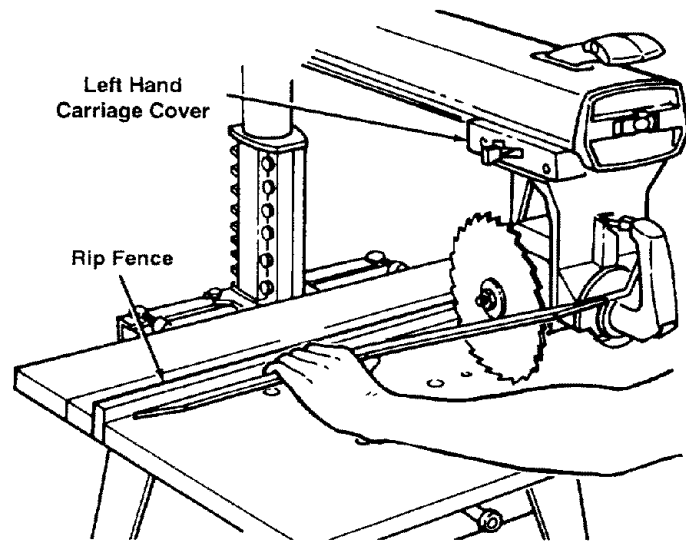

Make Blade Parallel to Table

The goal of this adjustment is to keep the workpiece from being thrown or damaged. This adjustment will also reduce splintering of the workpiece and burning of the kerf during ripping and crosscutting.

1. Lock arm in straight crosscut position.
2. Pull blade forward and lock rip lock.
3. Raise blade at least 2" above table.
4. Lock motor at 90° bevel (blade horizontal).
5. Place square so long side is on table under right side of blade, and short side hangs down vertically at front of saw.
6. Lower radial arm until blade surface, not a tooth, just rests on square.
7. There should be no gap between blade and square. **Note:** *Not all blades are perfectly flat. Check different points along blade surface by making quarter turns and looking for gap each time. Consider overall fit of blade.* If there is no gap, no adjustment is needed.
8. If there is a visible gap between saw blade and square, a bevel heel condition exists and adjustment is required.
 - a. To correct, unlock bevel lock lever. Loosen the rear motor mount nut until you can rotate Cam. Rotate Cam as shown until gap between saw blade and square is eliminated.
 - b. Tighten nut.
 - c. Tighten bevel lock lever and recheck blade to square.
 - d. Reposition motor to crosscut position with blade at rear of arm.

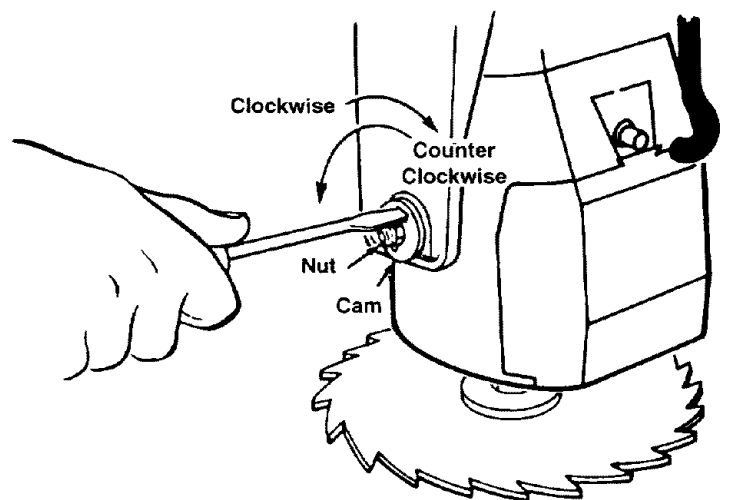
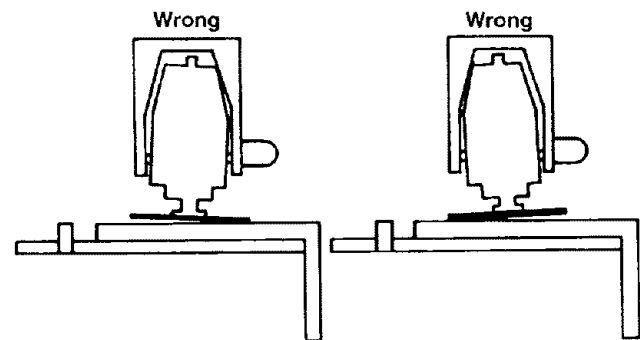
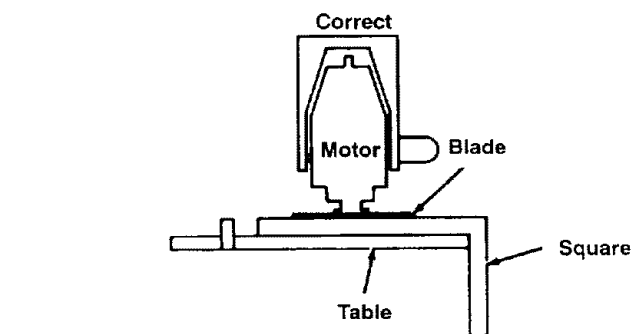
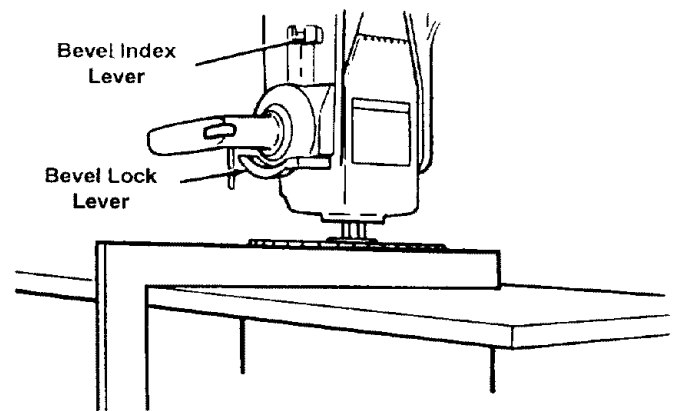

Alignment

Installing and Adjusting Rip Scale Indicators.

Note: The rip scales and pointers are intended to be used for quick settings. For greater accuracy, take direct measurement between blade and fence.

1. Pre-assemble indicator and twin nut. Loosen but do not remove two screws which attach left hand carriage cover.
2. Tilt carriage cover and install rip indicator with twin nut on inside of cover. Tighten carriage cover attaching screws.
3. Loosen but do not remove rip lock knob in right hand carriage cover. Install rip indicator. Tighten carriage cover attaching screws.
4. With fence in its normal position (next to front table), loosen yoke lock handle, pull yoke index lever forward and rotate yoke to the left to index yoke 90° from the cross cut position. This will locate saw blade between motor and fence. Lock yoke lock handle.
5. Position carriage until edge of blade, when spun by hand, just touches front face of fence. The rip-scale indicator (on the right hand side of radial arm) should now read "0" inches on upper portion of the blade "In-Rip" scale. If not, loosen screws and shift the indicator until it is aligned with the "0" mark, then tighten the screws.

Note: With saw blade and fence in the position shown, the upper portion of blade "In-Rip" scale is used. If fence is moved to extreme rear position, the lower portion of blade "In-Rip" scale would be used.

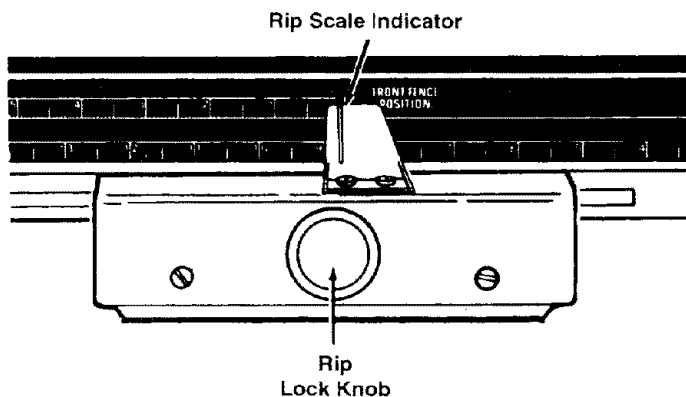
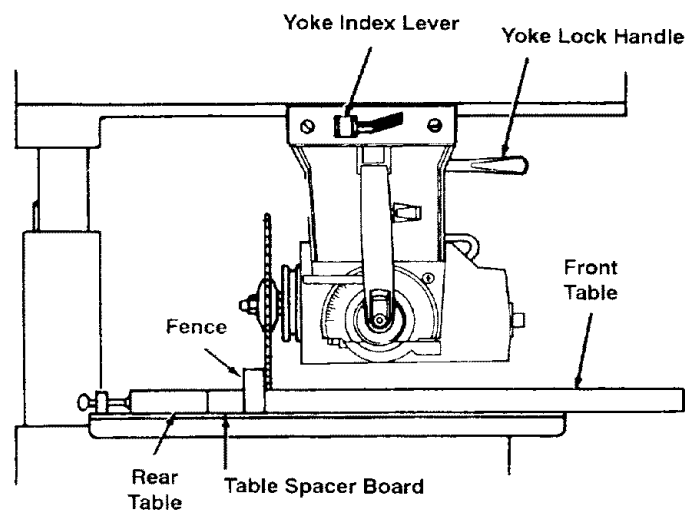
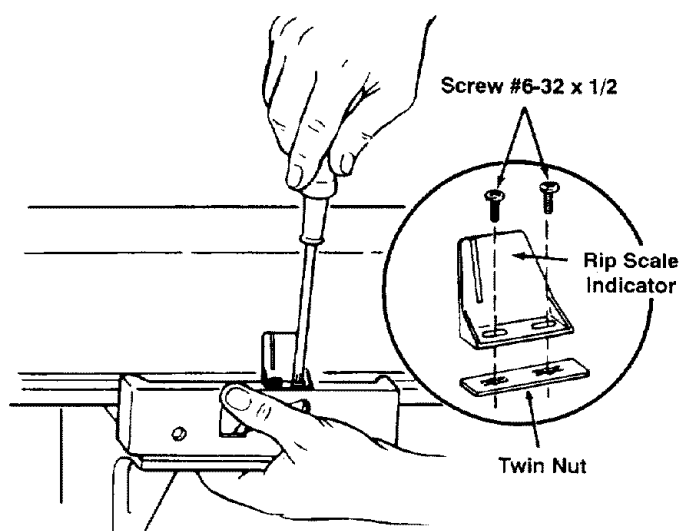

Alignment

6. The blade "Out-Rip" scale indicator on left hand side of the radial arm is adjusted in essentially the same manner as blade "In-Rip" indicator, except position blade with 2 inches between fence and face of saw blade. The rip-scale indicator should be positioned to read 2 inches on upper portion of the blade "Out-Rip" scale.

Note: With saw blade and fence in the position shown, the upper portion of the blade "Out-Rip" scale is used. If fence is moved to extreme rear position the lower portion of blade "Out-Rip" scale is used.

7. Loosen the yoke lock handle, pull the yoke index lever forward and return the blade to the crosscut position.

Note: Blade is now aligned. It is important that you periodically check alignment and adjustment to insure accurate cuts and improve and safety of cutting procedures.

Install Guard

The guard is a very important safety feature. It covers a large part of the blade and helps protect against severe cuts. Always use the guard.

1. Lock motor at 0° bevel (blade vertical).
2. Use one hand to lift clear plastic guard; use other hand to grasp rear of guard (below dust elbow). Position guard so riving knife faces front of saw.
3. Tilt front of guard down about 45°; place over blade; rotate guard to level position.

Note: Make sure notch in guard fits onto tab on motor. This will prevent movement of guard about motor. Squeeze handle trigger to make sure it fully raises clear plastic guard. If it does not, remove and re-install guard, making sure that trigger mechanism engages pull link on guard.

4. Tighten guard clamp screw.

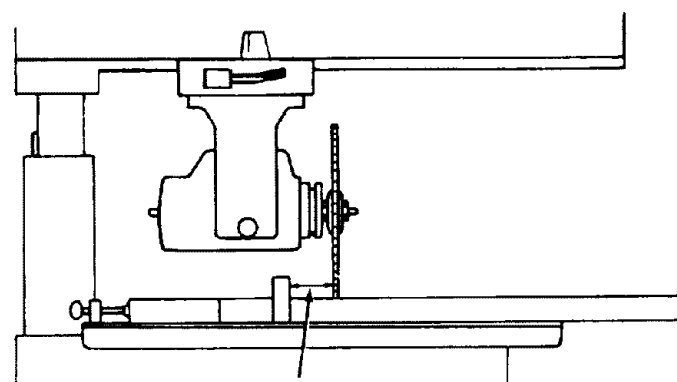

2"-Measured from fence to nearest blade tooth

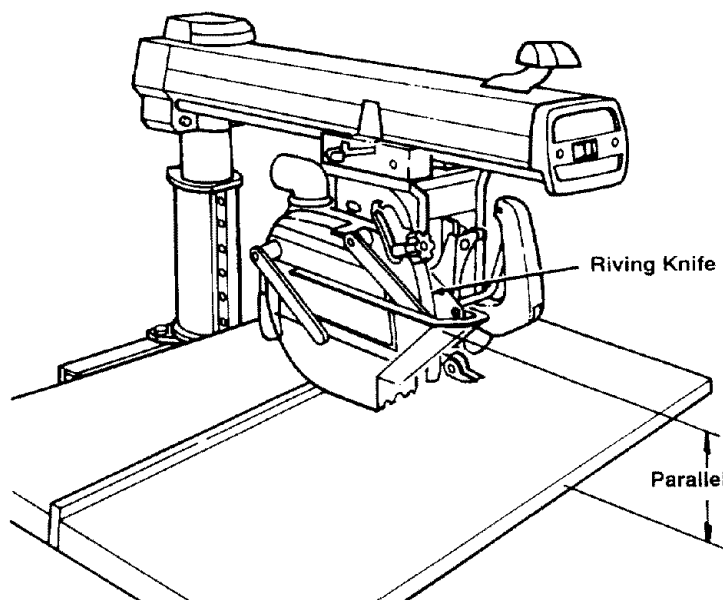

Alignment

Align Riving Knife to Blade

The goal of this adjustment is to position the riving knife directly in line with the blade.

Riving knife alignment is an important safety factor. The riving knife rides in the kerf of the cut workpiece during ripping to keep the two sides of the workpiece from pinching on the blade. Blade pinching is a cause of kick-back.

1. Lock yoke in in-rip position (blade towards column, motor towards front of arm).
2. Lower arm until blade just clears table.
3. Unlock rip lock while holding up lower plastic guard, move yoke back until blade touches fence. Lock rip lock.
4. Loosen pawls/riving knife knob. Lower riving knife to the table and tighten knob. The riving knife should rest flat against fence.
5. If adjustment is needed:
 - i) loosen riving knife bracket screw.
 - ii) slide riving knife so it rests against fence.
 - iii) secure riving knife bracket screw.
6. Raise riving knife and tighten pawls/riving knife knob.

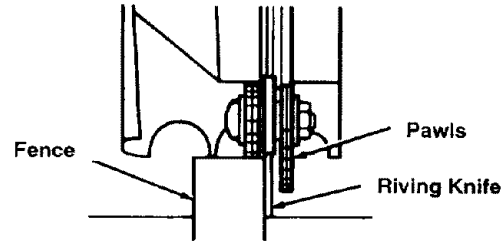

Correct: Blade and Riving Knife are in Line and Flat Against Fence.

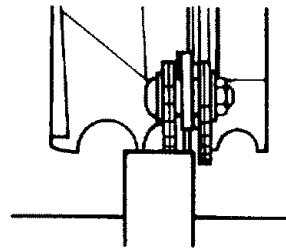

Wrong: Riving Knife on Top of Fence.

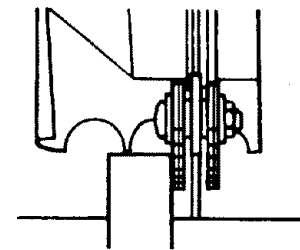

Wrong: Riving Knife Away From Fence.

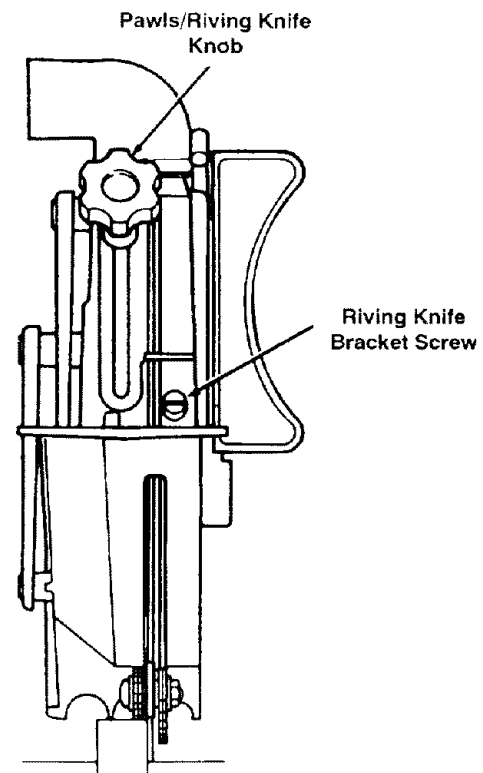

Controls

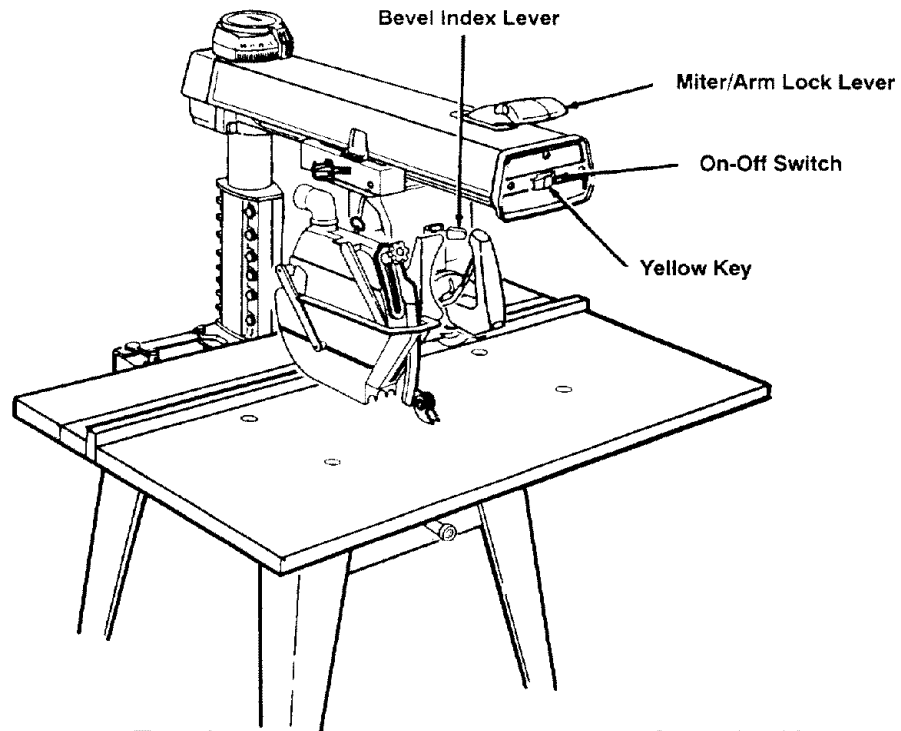

<u>Control</u>	<u>Function</u>	<u>Operation/Comments</u>
Miter/Arm Lock	Frees radial arm to move; locks in any desired position; pre-set indexed positions at 0°, 45°L, 45°R	Pull lever forward to release index then swing arm left or right <i>Hold in unlocked position while moving arm</i>
On-Off Switch	Turns motor on/off	Pull on, push off <i>Requires yellow key</i>
Yellow Key	Allows saw to be switched on	Insert into on-off switch <i>Remove after turning saw off</i>
Bevel Index Lever	Indexes the saw blade to 0°, 45°, or 90° pre-set index positions	Move bevel index lever to the left while positioning the blade, then release it

Controls

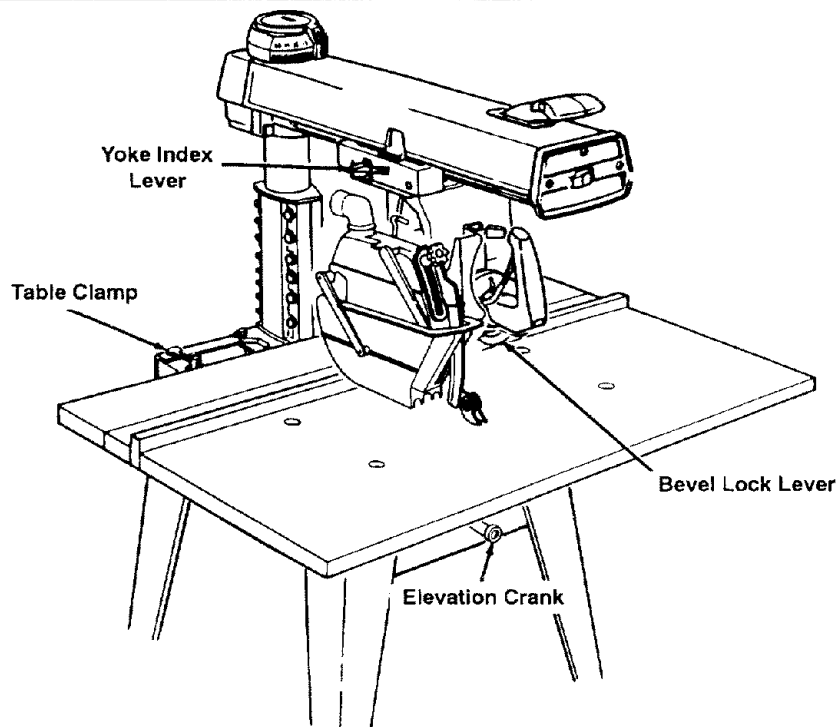

<u>Control</u>	<u>Function</u>	<u>Operation/Comments</u>
Bevel Lock Lever	Frees motor to rotate; locks in any desired position	Pull lever to release and push to lock <i>Support motor before unlocking because it can swing down quickly</i> <i>Bevel index lever must be un-indexed before moving motor</i>
Elevation Crank	Raises/lowers radial arm	Turn clockwise to raise, counterclockwise to lower
Table Clamp	Frees table sections to allow changing fence position	Turn clockwise to tighten, counterclockwise to loosen
Yoke Index Lever	Frees yoke to rotate between rip and crosscut positions	Pull the spring loaded yoke pivot latch forward to release this pin

Controls

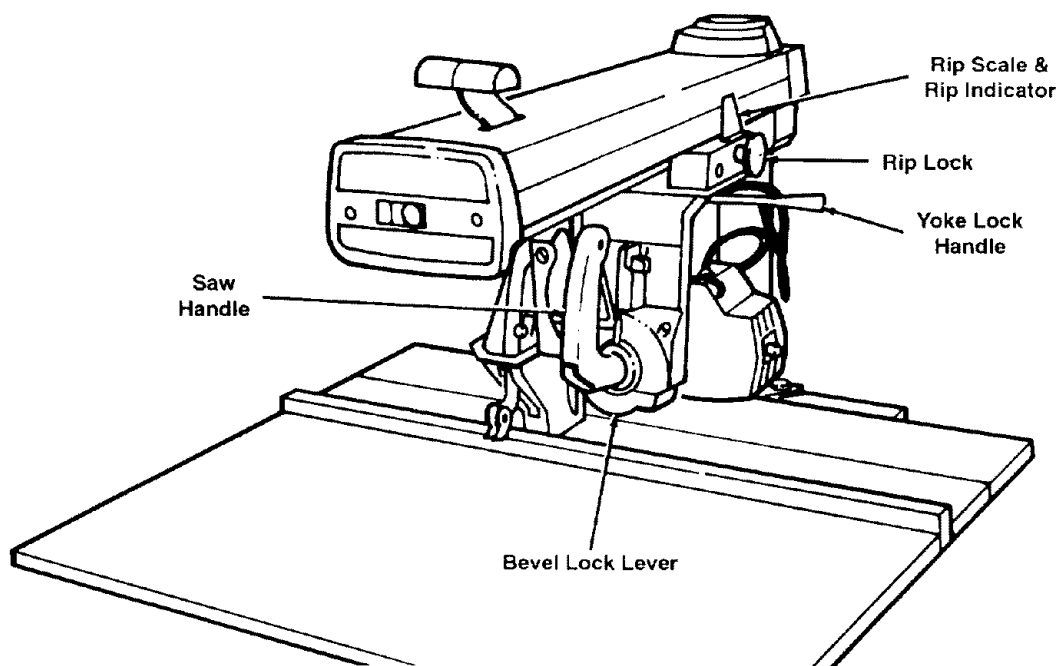

<u>Control</u>	<u>Function</u>	<u>Operation/Comments</u>
Yoke Lock Handle	Locks yoke in rip or crosscut position	Pull handle forward to release; push handle reward to tighten <i>Yoke index lever must be un-indexed before rotating yoke</i>
Rip Lock	Locks carriage to radial arm for ripping	Rotate counterclockwise to release carriage; turn clockwise to lock carriage in position <i>Lock before ripping</i>
Rip Scale & Rip Indicators	Tells approximate distance between blade and fence when saw is in in-rip or out-rip position	Move blade carriage along arm to align line on indicator with desired number on scale
Saw Handle	Provides grasping surface so carriage can be moved. Contains trigger mechanism to raise clear plastic guard when making a crosscut	Grasp to move blade carriage <i>Squeeze trigger to fully raise clear plastic guard. Clear guard must be raised over fence to crosscut</i>

Controls

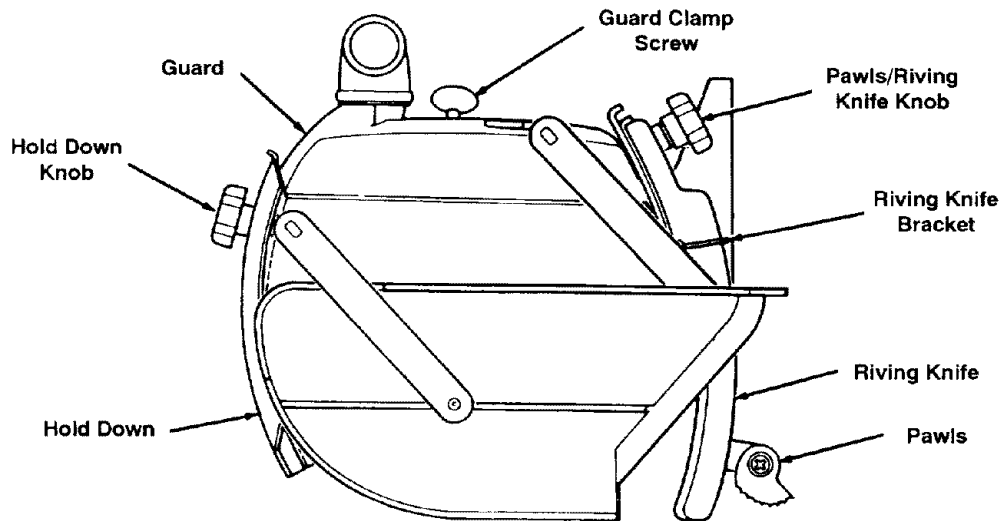

<u>Control</u>	<u>Function</u>	<u>Operation/Comments</u>
Guard Clamp Screw	Secures guard to motor; frees guard for removal	Turn counterclockwise to loosen, clockwise to tighten
Guard	Protects against contact with upper blade; partially protects against contact with lower blade; acts as sawdust deflector	Upper part remains fixed in level position. <i>Notch in guard fits securely into matching tab on motor</i> Clear guard is moveable: fully raise over fence to crosscut; <i>See Saw Handle</i> ; most workpieces will automatically raise clear guard during ripping; <i>See Guard Tab</i>
Hold Down Knob	Frees hold down to move up and down; locks hold down in place	Turn counterclockwise to loosen, clockwise to tighten
Hold Down	During ripping, acts as partial barrier to infeed side of blade; keeps infeed side of workpiece from fluttering; acts as sawdust deflector	For ripping, lower hold down to top of workpiece surface, then raise slightly and lock in place. For crosscutting lock in fully raised position
Riving Knife Bracket	Prevents side to side movement of riving knife and provides means for adjusting alignment	Loosen to align riving knife, then tighten

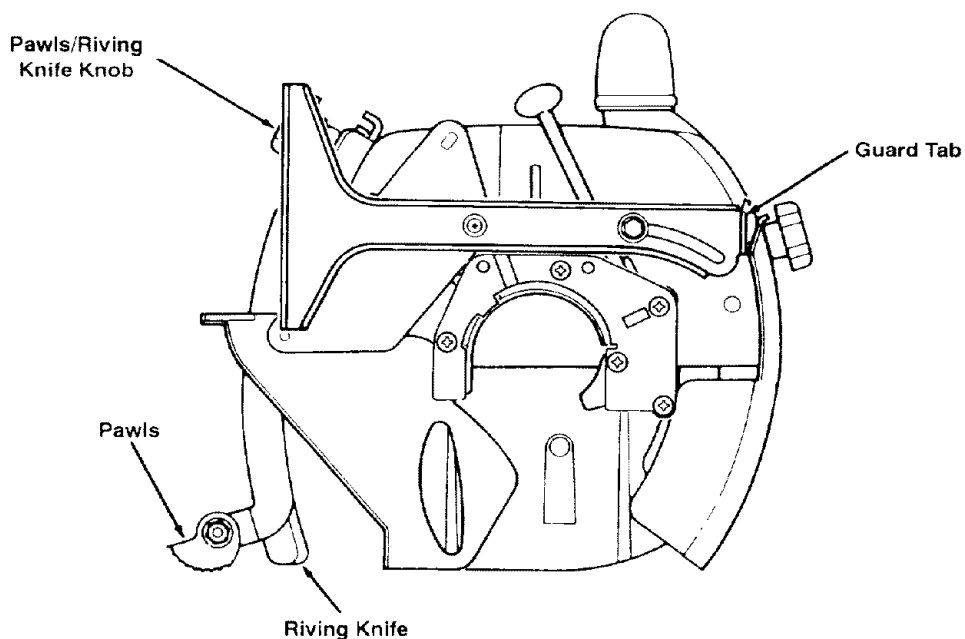

Control

Function

Operation/Comments

Guard Tab

Provides manual way to raise clear plastic guard during ripping when workpiece fails to raise it

Push and hold until workpiece clears guard, then release

Pawls/Riving Knife Knob

Frees pawls and riving knife to independently move up and down

Turn counterclockwise to loosen, clockwise to tighten

Pawls

During ripping, slow or stop kickback by digging into workpiece; when lowered during crosscutting, provide partial barrier to leading edge of blade

For ripping, set pawl level on workpiece surface. *For safety reasons set pawls before ripping; See Ripping Set-Up for details and illustrations*

Riving Knife

Reduces kickback by keeping kerf open; when lowered during crosscutting, provides partial barrier to leading edge of blade

For ripping, lower to table *For safety reasons riving knife must be in line with blade. See Alignment: Riving Knife to Blade*

Electrical Connections

Motor Specifications

The AC motor used on this saw is a capacitor-start, non-reversible type. The model covered in this manual has the following specifications:

Specification:	Model
	113.196380
Rated H.P.	1.5
Max Developed H.P.	3.0
Voltage	120/240
Amperes	13/6.5
Hertz (cycles)	60
Phase	single
RPM	3450
Arbor Shaft Rotation	clockwise
Run Capacitor	Yes

Note: *If saw does not start when switched on, immediately turn saw off and refer to Troubleshooting. Leaving the switch on will destroy the motor.*

Power Supply

⚠ WARNING

Saw is factory wired for 120V operation. Connect to 120V, 15-AMP branch circuit and use 15-AMP time delay fuse or circuit breaker.

Failure to connect in this way could result in injury from shock or fire.

The saw must be properly grounded. Not all outlets are properly grounded. If you are not sure that your outlet is properly grounded, have it checked by a qualified electrician.

⚠ WARNING

If not properly grounded, this power tool could cause electrical shock, particularly when used in damp locations.

⚠ WARNING

If electrical shock occurs, your reaction to shock could bring hands into contact with blade.

⚠ WARNING

To avoid electric shock or fire, immediately replace worn, cut, or damaged power cord.

The unit is wired for 120V and has a plug that looks like this:

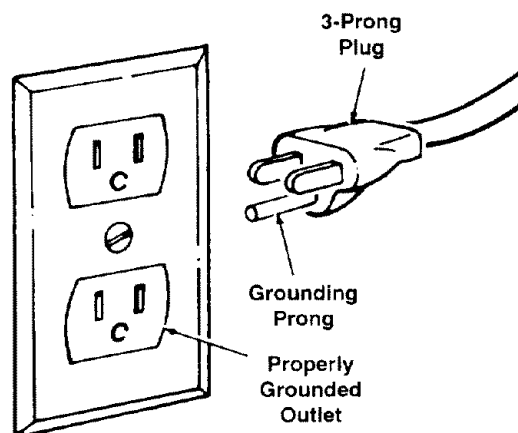

The power tool is equipped with a 3-conductor cord and grounding type plug listed by Underwriters' Laboratories. The ground conductor has a green jacket and is attached to the tool housing at one end and to the ground prong in the attachment plug at the other end.

The plug requires a mating 3-conductor grounded type outlet as shown above. If you have an outlet that is of the 2-prong type, it is recommended that you have a qualified electrician replace it with a properly grounded 3-prong outlet.

Electrical Connections

⚠ WARNING

To maintain proper tool grounding, if outlet you are planning to use for this power tool is a 2-prong type do not remove or alter grounding prong in any manner.

An adapter is available for connecting the plug to 2-prong receptacles. The green grounding lead or grounding lug extending from the adapter must be connected to a permanent ground such as to a properly grounded outlet box.

Extension Cords

Note: Make sure the proper extension cord is used and is in good condition.

The use of any extension cord will cause some loss of power. Determine the minimum wire size (American Wire Gauge No. (AWG #)) extension cord per table. Use only 3-wire extension cords with 3-prong grounding type plug and 3-pole receptacles which accept the tool's plug.

Motor Protection & Reset Button

The motor protector opens the circuit and stops the motor when the motor temperature exceeds a safe level, the motor is overloaded, or a low voltage condition exists.

When the protector activates, immediately turn saw off, remove yellow key and wait for motor to cool. Push red re-set button and listen/feel for click to indicate protector is re-set. If you do not hear/feel a click, motor is still too hot. Wait a while longer and repeat. (It may take over one hour for the motor to cool sufficiently for protector to reset.)

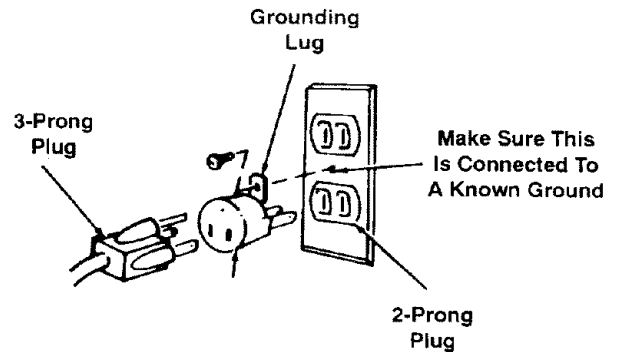

Note: The adapter illustrated is for use only if you already have a properly grounded 2-prong receptacle.

Extension Cord Length	Wire Sizes Required for 120V (A.W.G.)
110-120V	
0-25 Ft.	14
26-50 Ft.	12

Note: The smaller the gauge number, the heavier the cord. For circuits farther away from the electrical circuit box, wire size must be increased proportionately to deliver ample voltage to the motor.

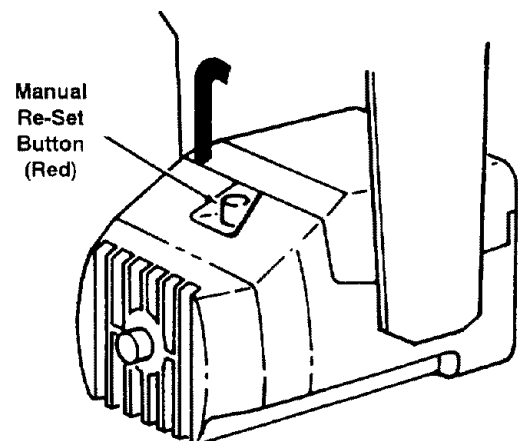

Electrical Connections

Dual Voltage Motors

Models 113.196321 and 113.196421 ONLY!

To Change Motor Voltage to 240 A.C.

Under normal home workshop conditions, if full voltage is supplied to the motor, your saw will operate efficiently on 120V. If any of the following conditions exist, it will be advisable to have a qualified electrician reconnect the motor for 240V operation:

- heavy duty operation
- either undersized or overloaded branch circuit serves the saw
- power company cannot correct a low voltage situation.

The following procedure to change motor voltage should be performed only by a qualified electrician. **Note:** *Whenever changing the switch position from 120 to 240V, make certain that all necessary steps (including proper fusing of the branch circuit) are completed.*

1. Unplug saw.
2. Remove pan head screw from top of motor cover. Remove motor cover panel at blade end of motor.
3. Use small screwdriver to slide dual voltage switch to 240V position.
4. Re-install motor cover panel.
5. Replace 120V power cord plug with 240V, 15 amp, 3-prong plug.
6. Connect power cord white and black leads to two "hot" plug blades; connect power cord grounding wire to plug ground prong.
7. Plug cord into 240V, 15 amp, 3-blade receptacle. Make sure receptacle is connected to a 240V A.C. power supply through a 240V branch circuit having at least a 15 amp time delay fuse or circuit breaker. **Note:** *No adapter is available for this type plug.*

DANGER

To avoid electric shock, unplug saw before changing motor voltage.

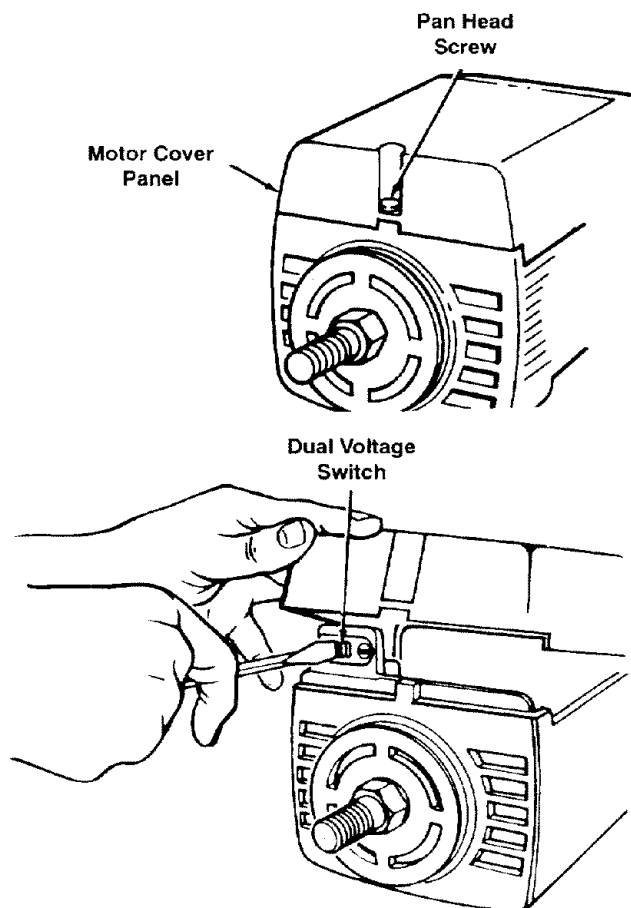

Crosscutting

Crosscutting Defined

Crosscutting is cutting a workpiece to length. The workpiece is held firmly against the fence, and the blade is pulled through the workpiece to make the cut. Straight, bevel, miter, and compound cuts can be made.

Crosscutting Safety

The hazards associated with crosscutting include: exposed blade teeth, rolling carriage, and thrown workpiece. This section explains these hazards and tells how to avoid them or reduce the risk of their happening.

Read this section before making any type of crosscut. Follow these steps every time you make a crosscut.

Exposed Blade Teeth

WARNING

During crosscutting, blade teeth can be exposed. To reduce risk of having fingers, hand or arm cut off:

- ✓ Correctly install and use guard.
- ✓ Lower pawls or riving knife to clear fence or workpiece, whichever is higher, by 1/4". Lowered pawls or riving knife act as partial barrier to front of blade.
- ✓ Keep hands away from blade and out of blade path. Keep hand holding down workpiece at least 8" from blade.
- ✓ Blade can come off table edge beyond 30° left miter position. Use right miter position whenever possible.
- ✓ Do not cut freehand. You will not be able to control workpiece.
- ✓ If blade jams, turn off saw, remove yellow key, then free blade.

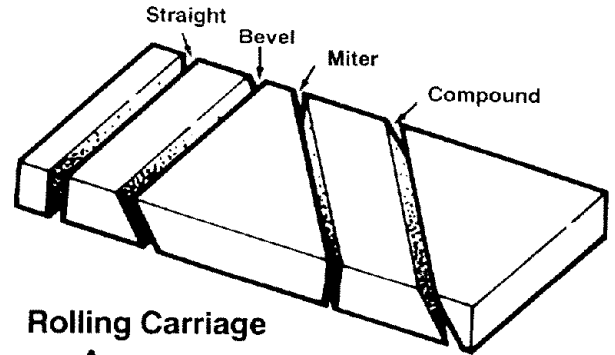

Rolling Carriage

WARNING

When saw is turned on, blade can suddenly come forward. To reduce risk of this happening:

- ✓ Keep one hand on saw handle when turning saw on.
- ✓ Adjust leveling feet to make sure radial arm slants slightly toward rear.

Thrown Workpiece

CAUTION

Workpiece could be picked up by spinning blade and thrown. You might be hit by thrown workpiece. To reduce risk of thrown workpiece:

- ✓ Make sure installed fence is at least half as high as the workpiece, and never less than 3/4".
- ✓ Start and finish cut with blade in rear-most position, behind fence.
- ✓ Firmly hold workpiece flat on table and up against fence. Cut only one workpiece at a time.
- ✓ Pull blade through workpiece only far enough to complete cut, and never more than half the diameter of blade.
- ✓ Do not touch or move workpieces until blade has stopped spinning.
- ✓ Use length stop only on end of workpiece which is held down.
- ✓ Use table extensions to support workpieces that extend beyond table.

Crosscutting

Crosscut Kerfs

A kerf or shallow cut is needed in the table and fence to serve as a path for the blade and to ensure that the blade cuts all the way through the workpiece. **A kerf is needed for each different cutting path.**

To make an approximately 1/16" deep kerf:

1. Prepare table:
 - put fence in front position
 - tighten table clamps
2. Prepare blade:
 - lock blade in crosscut position
 - lock radial arm at desired miter angle
 - lock motor at desired bevel angle*
 - unlock rip lock and push blade to rearmost position, behind fence
 - lower blade* to just clear table
 - lower pawls or riving knife to clear fence by 1/4".

** raise clear plastic guard before changing bevel angle and when lowering beveled blade, otherwise it may jam into table.*

3. Grasp saw handle, then turn saw on. **Keep one hand on saw handle through step 6.**
4. Slowly lower blade until it touches table, then lower one more full turn of crank.
5. Squeeze handle trigger to fully raise clear plastic guard so it will clear fence. Pull blade through fence and across table as far as it will go.
6. Push blade to rearmost position, behind fence, and turn saw off. Keep hand on saw handle until blade stops spinning.

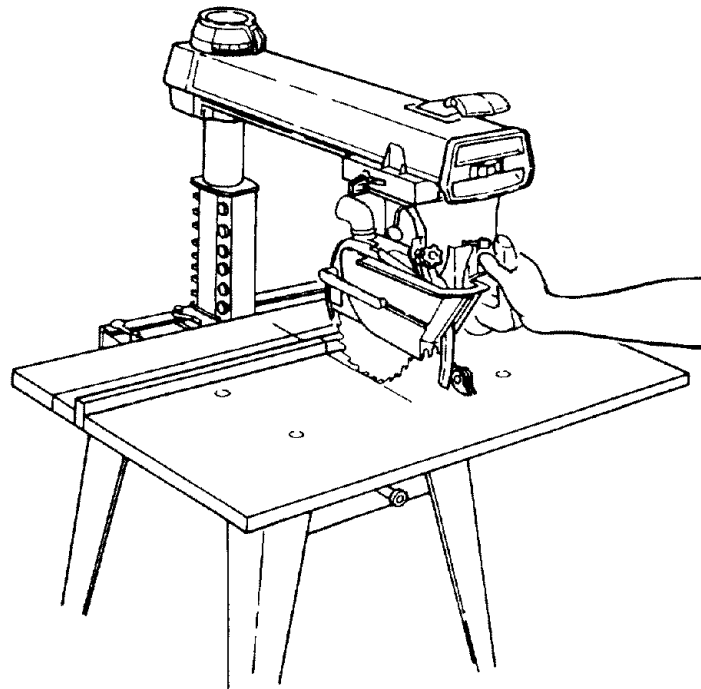
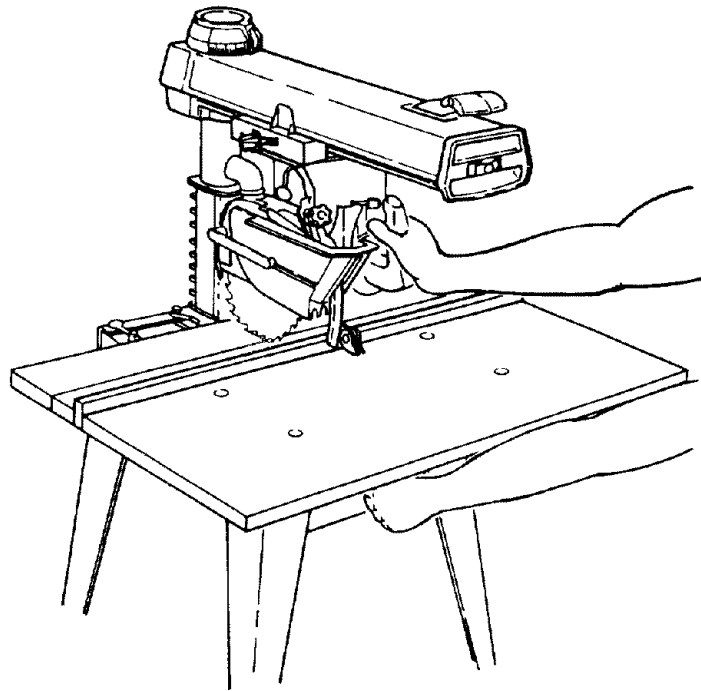

Crosscutting

Making Crosscuts

Follow these steps to make crosscuts.

1. Prepare table:

- put fence in front position
- tighten table clamps

2. Prepare blade:

- lock blade in crosscut position
- lock radial arm at desired miter angle
- lock motor at desired bevel angle*
- unlock rip lock and push blade to rearmost position, behind fence
- lower blade into kerf* but not touching kerf bottom (blade should move freely).

* raise clear plastic guard before changing bevel angle and when lowering beveled blade, otherwise it may jam into table.

3. Position workpiece against fence, and lower pawls or riving knife to clear fence or workpiece, whichever is higher, by 1/4".

4. Grasp saw handle, then turn saw on. **Keep one hand on saw handle through step 7.**

5. Hold workpiece down and against fence. Keep hand at least 8" away from blade.

6. Squeeze handle trigger to fully raise clear plastic guard so it will clear fence and workpiece. Pull blade through workpiece but only far enough to complete cut, and never more than half the diameter of blade.

7. Push blade carriage to rearmost position, behind fence, and turn saw off. Keep hand on saw handle until blade stops spinning.

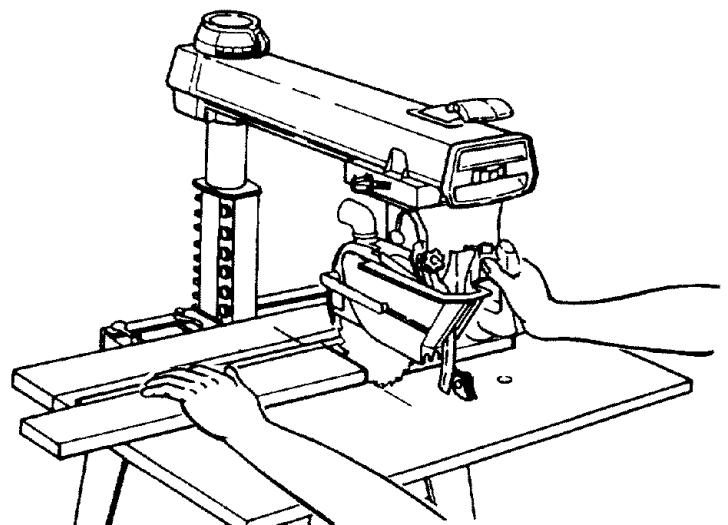
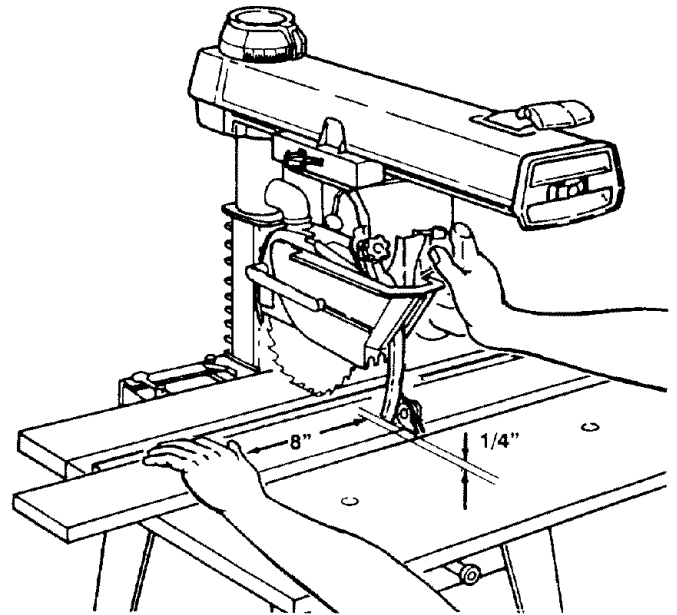

Crosscutting

Repetitive Crosscutting

Repetitive crosscutting is the repeated and continuous cutting of many pieces of lumber to the same length. Carriage and length stops can help make this type of crosscutting more efficient.

A carriage stop defines the distance needed to pull the blade through to complete each cut. This will prevent pulling the blade through more than the recommended distance.

To make a carriage stop use 1x2 lumber:

- i) cut two pieces, each 2" long
- ii) clamp a piece on each side of radial arm, so blade carriage stops at distance needed to complete cut
- iii) check that clamps do not interfere with hand grip on saw handle.

A length stop defines the cut length and ensures that all pieces will be cut to the same size. Clamp a piece of 1x2 lumber on the fence to define the cut length. **Use a length stop only on the end of the workpiece which is held down.**

Crosscutting Hints

1. To extend life of table top, buy auxiliary table cover (see Accessories) or make one out of 1/4" plywood or fiberboard. Clamp or nail to original table top, section by section. If you use nails, nail in the four corners to make sure blade will not contact nails.
2. Make several fences, so each will have only a few kerfs (See Cutting Aides). Too many kerfs will weaken a fence.
3. Keep table clean of chips and sawdust.
4. Use sharp blades, and use the right blade for each job.
5. When making miter or bevel cuts, use extra force to hold workpiece down because it tends to move during these types of cuts.
6. When cutting hard woods, like oak, or making compound cuts, keep arm holding saw handle rigid and pull blade through slowly.
7. To keep cut line accurate, periodically check blade alignment.
8. Do not cut severely warped or crooked workpieces.

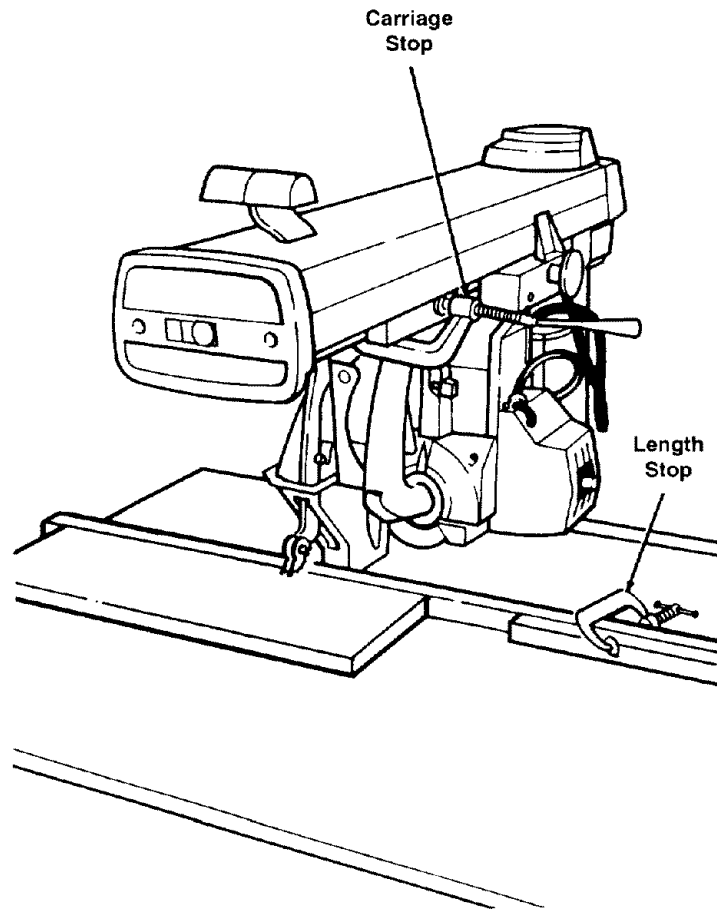

Ripping

Ripping Defined

Ripping is changing the width of a workpiece by cutting along its length. The workpiece is fed into the blade, which rotates in a fixed position, parallel to the fence and a set distance from the fence. A solid fence (no kerfs) serves as a guide for the workpiece. Place the fence in the front position for narrower workpieces, or in the rear position for wider ones.

In-Rip and Out-Rip Positions

In-rip and out-rip refer to blade position.

In-rip: the blade is toward the column, and the motor is toward the table front. In-rip is recommended because this position allows better visibility of the workpiece and your hands. Use in-rip when you set the blade 1/2 to 16" from the fence.

Out-rip: the blade is toward the table front, and the motor is toward the column. Use out-rip only when you set the blade 12" or more from the fence.

Infeed and Outfeed Directions

Infeed and outfeed refer to sides of the blade.

Infeed: the side of the blade where the guard hold down is. **Always start a rip cut at the infeed side and push the workpiece through to the outfeed side.**

Outfeed: the side of the blade where the pawls and riving knife are. **Never start a rip cut at the outfeed side. This is wrong way feed. Never put hands on the outfeed side of the blade when ripping because they can be pulled back into the spinning blade.**

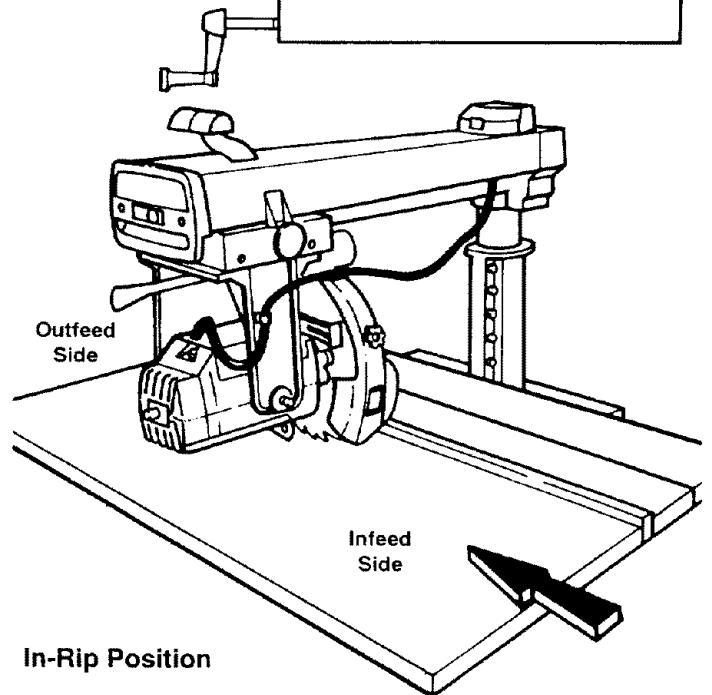
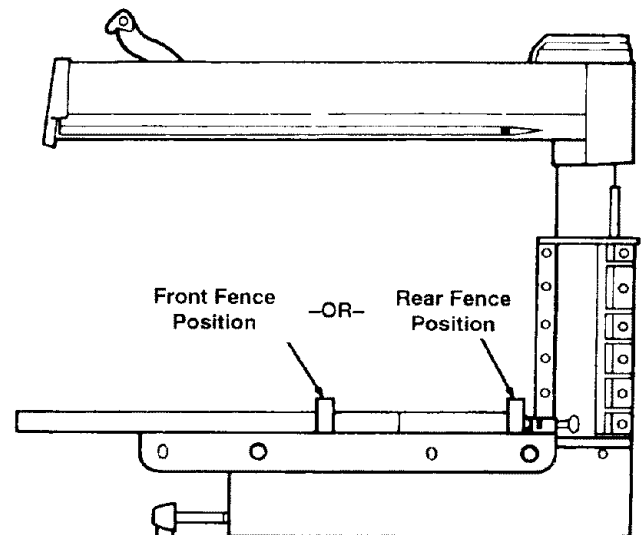

In-Rip Position

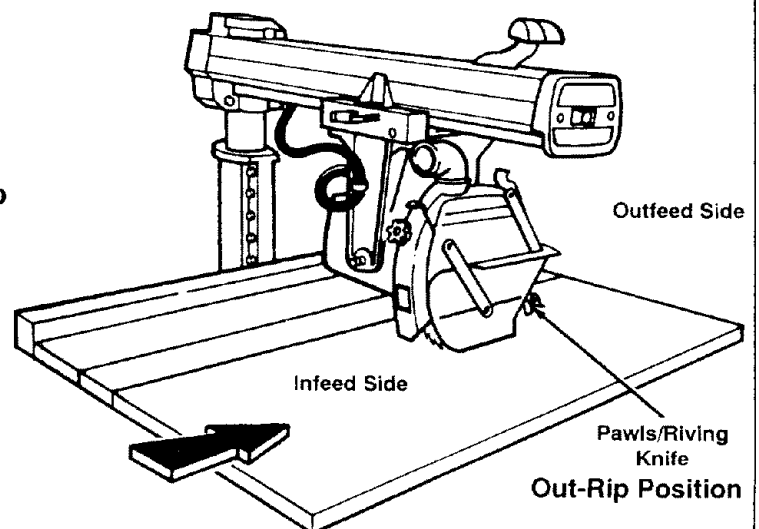

Out-Rip Position

Ripping

Workpiece Positioning

Always set up so that the wider part of the workpiece is between the blade and fence. This gives you greater clearance for push sticks, and allows better stability for feeding the workpiece.

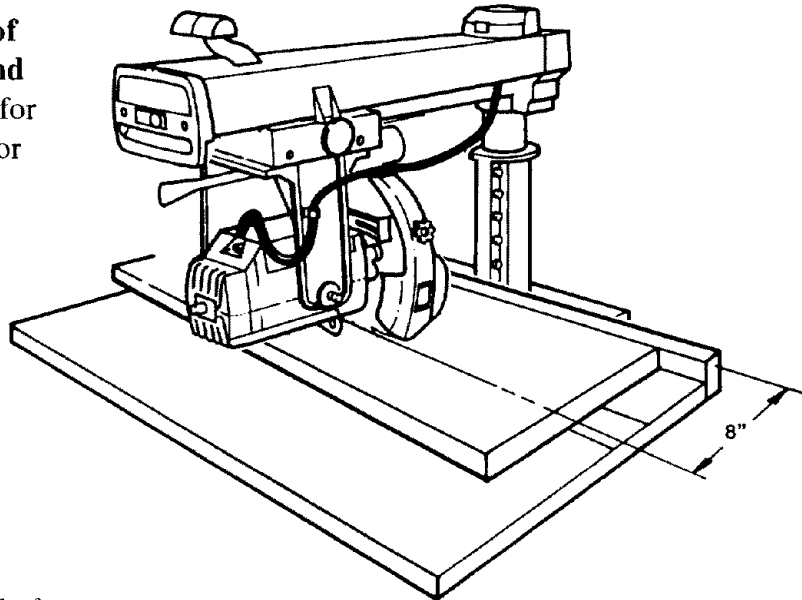

Example: To rip 2" off a 10" wide board, set blade in in-rip position 8" from rear fence.

Push Sticks and Push Blocks

Use push sticks and push blocks instead of the hands to push the workpiece through to complete cuts. They help keep hands away from the blade. A push block is used with an auxiliary fence. (see Cutting Aides).

Use a push block and auxiliary fence when the blade is set 1/2" to 2" from the fence.

Use a push stick when the blade is set 2" or more from the fence.

Do not set the blade closer than 1/2" to the fence. The radial saw is the wrong tool for such a narrow cut. A band saw would be more appropriate for this type of cut.

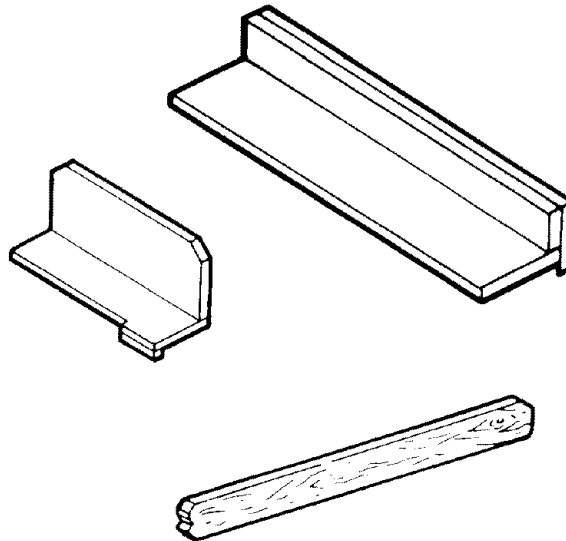

Ripping Safety

The hazards associated with ripping include: outfeed zone hazard, kickback, and wrong way feed. This section explains these hazards and tells how to avoid them or reduce the risk of their happening.

Read this section before making any type of rip cut. Follow these steps every time you make a rip cut.

Outfeed Zone Hazard

DANGER

Rotational force of blade can pull hands and fingers back into blade. Touching, holding, or pulling on outfeed side of workpiece while blade is still spinning will result in fingers, hand or arm being cut off.

To reduce risk of outfeed hazard:

- ✓ Set pawls and riving knife; they act as partial barrier to outfeed side.
- ✓ Start and finish cut from **infeed** side.
- ✓ Keep both hands on infeed side.
- ✓ Keep hands away from outfeed side.
- ✓ Push workpiece through to complete cut. Do not reach around to pull it.
- ✓ If blade jams, turn saw off, remove yellow key, then free blade.

Kickback

Kickback is the uncontrolled propelling of the workpiece back toward the user.

WARNING

Kickback can happen when blade is pinched or bound by workpiece. Pinching or binding can happen when:

- pawls and riving knife are not used or not set correctly
- riving knife is not aligned with blade
- blade is not parallel to fence
- workpiece is twisted or warped and rocks on table top
- pressure is put on outfeed side of workpiece
- workpiece is released before being pushed past pawls
- user touches or tries to pull workpiece through outfeed side before blade has stopped spinning.

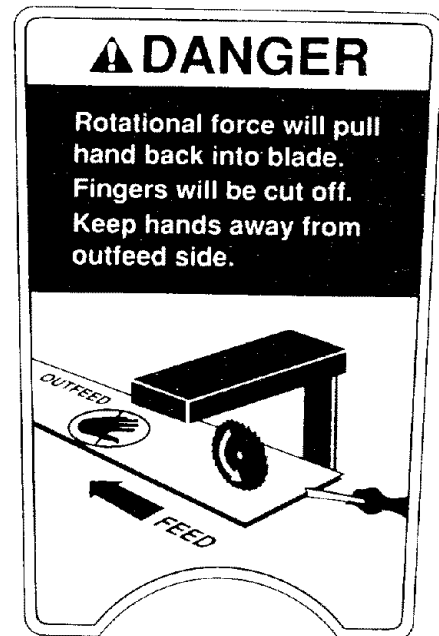

Ripping

To reduce risk of kickback:

- ✓ Set pawls and riving knife according to ripping set-up procedure. Correctly set riving knife is more likely to prevent workpiece from binding or pinching blade; correctly set pawls are more likely to grab into workpiece to stop or slow kickback if one happens.
- ✓ Check that riving knife is in line with blade (see Alignment: Riving Knife to Blade).
- ✓ Cut only straight workpieces so surface will lie flat on table and edge will stay tight against fence. If you must cut an irregular workpiece, attach a straight edge (see Cutting Aides).
- ✓ Push workpiece through from infeed to outfeed side until it is completely past pawls.
- ✓ Use featherboard (see Cutting Aides).
- ✓ Keep hands away from outfeed side.
- ✓ If blade jams, turn saw off, remove yellow key, then free blade.
- ✓ When cutting composition materials, or other materials with one smooth and one rough side, put rough side up so pawls will be more likely to grab.

Wrong Way Feed

Wrong way feed is ripping by feeding the workpiece into the outfeed side of the blade.

WARNING

Rotational force of blade will pull workpiece through violently if workpiece is fed in same direction as blade rotates (wrong way feed). Hands and fingers could be pulled along with workpiece into spinning blade before you can let go or pull back. Fingers, hand or arm could be cut off. Propelled workpiece could hit bystander.

To eliminate risk of wrong way feed:

- ✓ Feed workpiece against blade rotation.
- ✓ Set pawls and riving knife; they act as partial barrier to outfeed side.



Hold Down Function

The hold down must be set correctly during ripping to act as barrier against the infeed side of the blade, to help keep the workpiece flat on the table, and to deflect workpiece chips. It must be lowered to just clear the workpiece.

The hold down must be re-set each time a different thickness workpiece is cut.

Follow the Ripping Set-Up Procedure to correctly set the hold down.

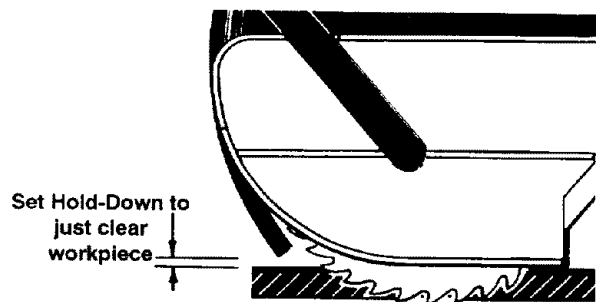

Pawls and Riving Knife Function

The pawls and riving knife must be set correctly during ripping to reduce the risk of kickback, to prevent wrong way feed, and to act as a barrier to the hazardous outfeed side of the blade.

The riving knife rests on the table. It keeps the workpiece kerf open. This reduces the chances that the cut workpiece will spring closed and pinch the blade. Pinching the blade is a cause of kickback.

The pawls rest level on the upper surface of the workpiece. During cutting they allow the workpiece to pass freely from the infeed to the outfeed side, but help stop the kickback motion from outfeed to infeed side by grabbing into the workpiece surface.

The pawls must be re-set each time a different thickness workpiece is cut.

Follow the Ripping Set-Up Procedure to correctly set the pawls and riving knife.

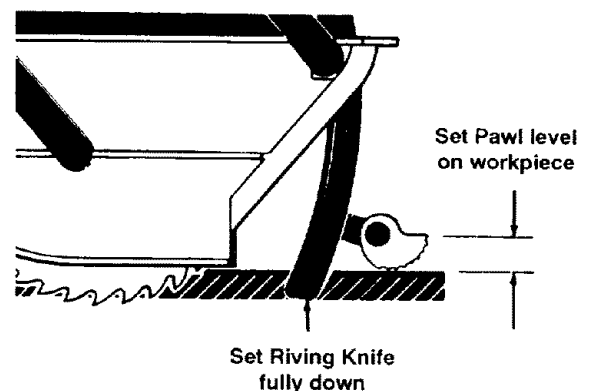

Ripping

Ripping Set-up Procedure

Follow these steps before ripping.

These steps must be repeated each time a different thickness workpiece is ripped. A kerf must be made for each different width cut. Also see the special notes for bevel set-up that follow this section.

1. Prepare table:
 - insert solid (no kerfs) fence (**Note:** Use auxiliary fence when blade is set 1/2 to 2" from fence (See Cutting Aides)
 - tighten table clamps.
2. Prepare blade:
 - lock radial arm at 0° miter
 - lock blade in in-rip position*
 - lower blade to just clear table
 - lock blade carriage desired distance from fence. **Note:** Make sure wider part of workpiece will be between blade and fence.

* use out-rip position for rips 12" or wider.

3. Make kerf:
 - a) turn saw on
 - b) lower blade about 1/16" into table
 - c) turn saw off and remove yellow key.
4. Place workpiece parallel to and up against blade.** **Note:** Workpiece will be between blade and table front.
5. Lower hold down** to workpiece, then raise slightly so it just clears top surface of workpiece. Lock in place.
6. Lower riving knife to table. **Lower** pawls to workpiece surface.** **Move** workpiece toward outfeed side until one set of pawls rests level on workpiece surface. Lock in place.

** bevel set-up: see special notes, next page

⚠ WARNING

If workpiece is pushed along fence with kerfs, workpiece could get caught on kerf, pinch blade and cause kickback. Do not use cross-cutting fence for ripping.

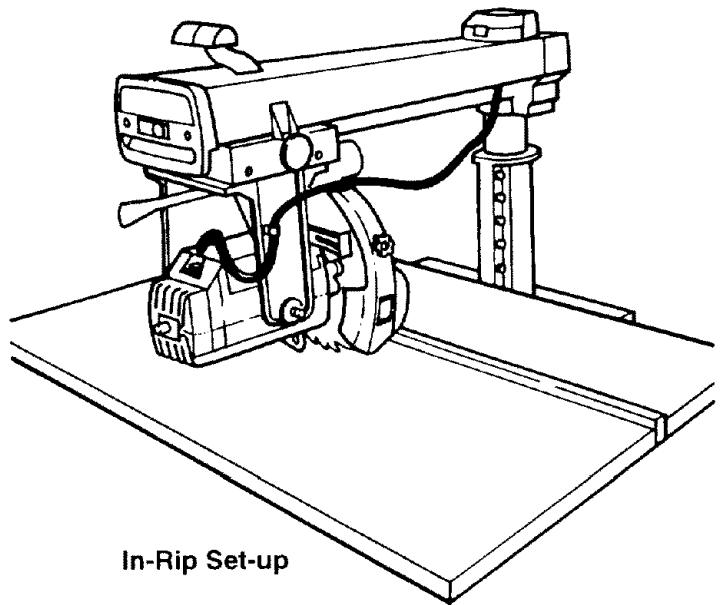

In-Rip Set-up

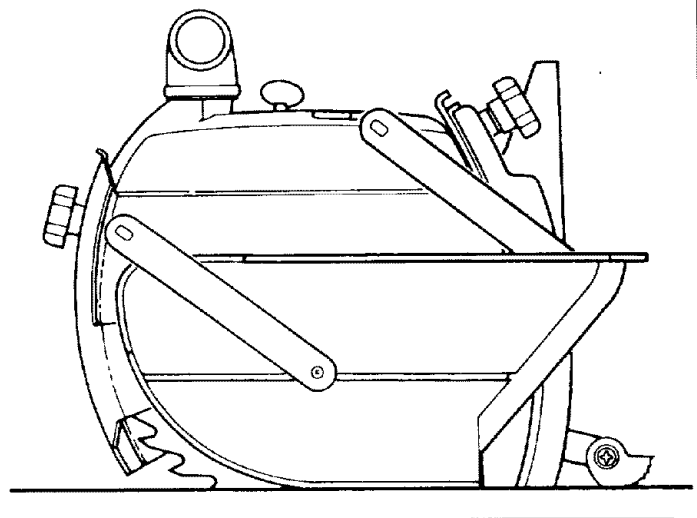

Setting Guard For Rip Cut

8. Remove workpiece from table.
9. Ready push stick or push block.
10. Set up table extension(s) and support their outer ends. **Do not use another person to support workpieces because this can cause kickback and it exposes helper to potential hazards at outfeed side.**

Special Notes for Bevel Set-Up

⚠ CAUTION

Bevel ripping creates unique problems of visibility and feeding. Before cutting, check the set-up using both in-rip and out-rip. Use the position that gives the best combination of workpiece visibility and push stick clearance.

⚠ WARNING

Bevel the edge that is not against the fence.

1. When setting bevel angle, raise radial arm to allow sufficient clearance for blade and guard to not jam in table.
2. When blade is beveled manually raise clear plastic guard before lowering blade to table or kerf, otherwise it may jam in the table.
3. To set hold down, place workpiece directly under guard nose, rather than parallel to blade.
4. To set pawls, place workpiece directly under set of pawls closer to table. This set of pawls will keep contact with workpiece surface.

Making Rip Cuts

Follow these steps to make in-rip cuts. For out-rip cuts, reverse hand functions; that is, put right hand on table and use left hand to support and push workpiece.

1. Follow ripping set-up procedure.

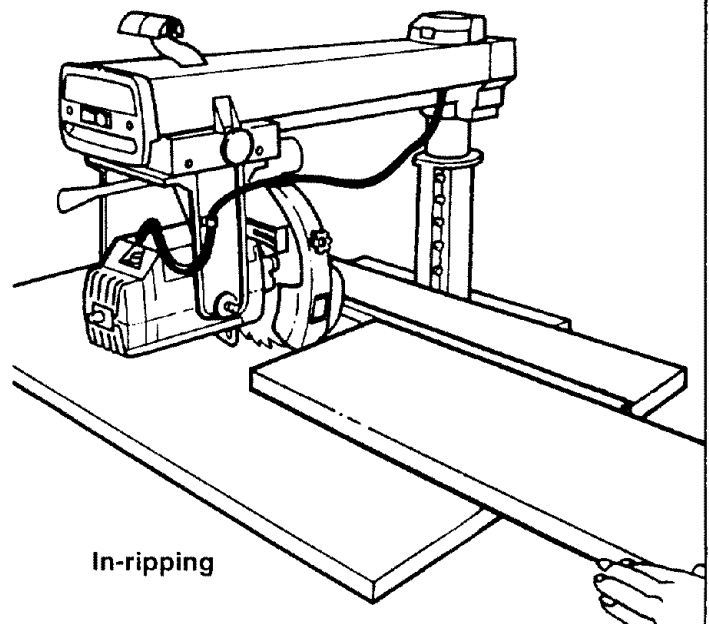
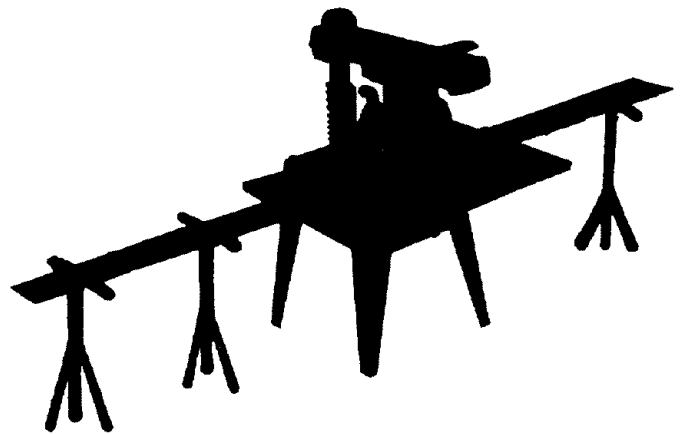

Ripping

2. Insert yellow key and turn saw on.
3. Stand at infeed side and out of line of workpiece, in case of kickback. **Start and finish cut from infeed side.**
4. Put workpiece on table, in front of hold down, and tight against fence. To hold workpiece in position, put left hand on table, at least 8" in front of hold down, and lightly press fingers against workpiece. Support workpiece with table extension or right hand.

⚠ CAUTION

For large workpieces use a featherboard in place of your hand on the table. It gives better support. (See cutting aides)

5. With right hand, push workpiece under hold down and into blade. Keep left hand fixed on table, applying slight pressure to keep workpiece against fence.
6. Use right hand to continue to apply feed pressure to part of workpiece close to fence. Keep hand at least 8" in front of hold down. **Note:** *Most workpieces will automatically raise clear plastic guard as they pass from infeed to outfeed side. Unusually tall and narrow workpieces may not raise clear guard. When this happens, push guard tab to raise guard, then release tab when guard rests on top of workpiece surface.*

⚠ CAUTION

Pushing guard tab means using only one hand to control workpiece. While pushing tab, use extra care to guide workpiece and to keep hand at least 8" in front of hold down. Release tab as soon as clear guard rests on workpiece.

7. When end of workpiece gets to table, use push stick or block, instead of hand, on part of workpiece between blade and fence to push until workpiece is completely past pawls.
8. Turn saw off and **wait for blade to stop spinning before touching workpiece.**

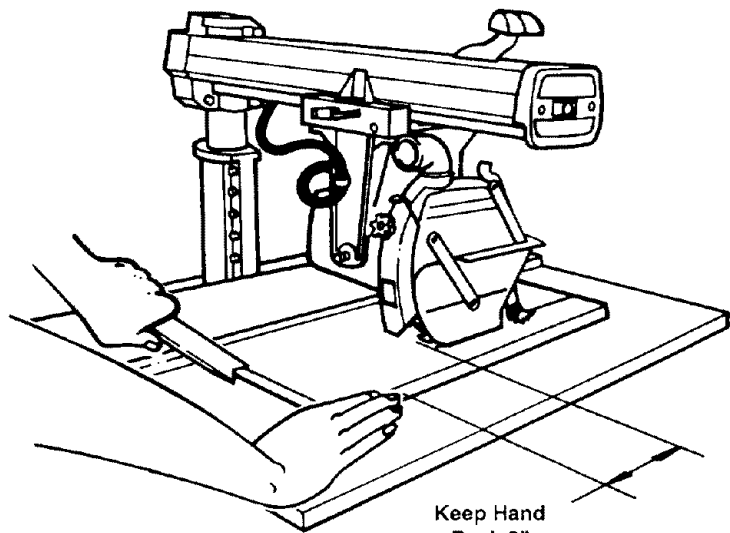

Out-ripping

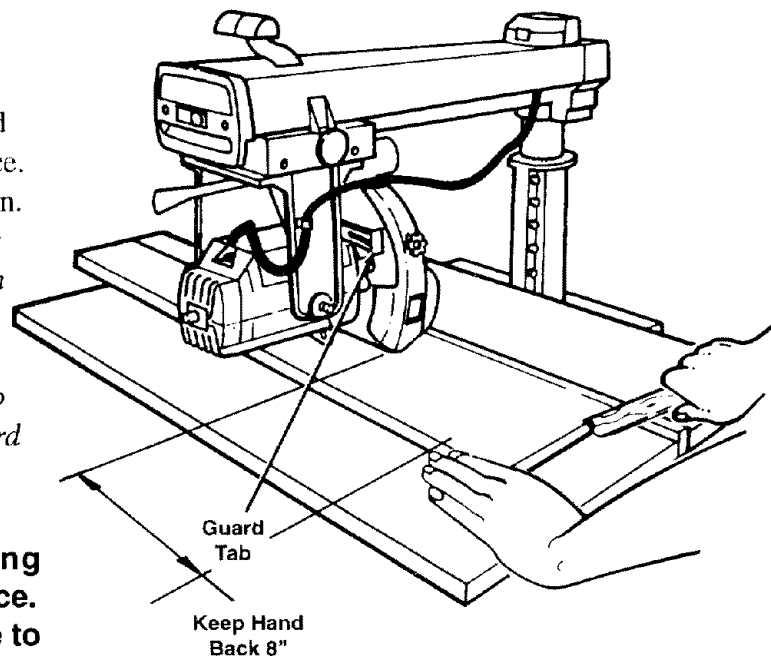

In-ripping

Dado Blades, Molding Heads

See Accessories for information on safety, installation and use of dado blades and molding heads.

Edging

Edging is the use of a dado blade or molding head in the horizontal position. It is an advanced technique that requires a molding head guard and a special fence. See Accessories for information on safety, installation and use of dado blades and molding heads for edging. See Cutting Aides for information on making the special fence.

Ripping Hints

1. To extend life of table top, buy an auxiliary table cover (see Accessories), or make one out of 1/4" plywood or fiberboard. Clamp or nail to original table top, section by section. If you use nails, nail in the four corners to make sure blade will not contact nails.
2. Keep table clean of chips and sawdust.
3. Use sharp blades.
4. Use the right blade for each job.
5. For workpiece with one smooth and one rough surface, such as paneling or finished fiberboard, cut with rough surface up so pawls will be more likely to grab in case of kickback.
6. To keep cut line accurate, periodically check blade alignment.
7. If you must cut an irregular workpiece, attach a straight edge (see Cutting Aides).

DANGER

Edging without a guard could bring hands and fingers too close to cutting tool.

Hands, fingers, and arm could be cut off.

- buy, install, and follow instructions for molding head guard
- use only dado or molding head for edging
- do not use blade because blade cannot be guarded when horizontal
- read and follow instructions in Accessories section of manual.

Cutting Aides

Before cutting any wood on your saw, study all of the Crosscutting and Ripping Instructions found on pages 45 through 57. As you learn new radial arm saw wood-working techniques, you'll see that many types of cuts need different support and feeding devices, known as jigs or fixtures. They can help you make cuts more accurately. By helping to steady the workpiece and keep you away from the blade, they can help you safely use your saw for certain cuts. Many people custom build their own jigs and fixtures. Jigs and fixtures are often designed for a particular cut. You can use your radial saw to easily make many jigs and fixtures. To get you started, we've included instructions for some simple ones. After you have made a few practice cuts, make up these jigs before starting any projects. Make the push stick first.

Push Sticks

Make the push stick using a piece of 1 x 2. (see drawing top right for dimensions and shapes)

Push Block

There are any number of ways to properly cut your work pieces to make a push block. The following steps describe one way you can proceed.

Making the base:

- Start with a piece of 3/8" plywood at least 5-5/8" wide or wider and 12" long or longer.
- Make two ripcuts. Perform the first ripcut along the long side of the 3/8" plywood to create a 3/8" wide strip. Next ripcut the 3/8" plywood to a width of 5-1/8".
- Crosscut the 3/8" plywood to 12" long.
- Crosscut a 2-1/2" piece off of the 3/8" wide by 3/8" thick strip and save this short piece for later.
- The next cuts will create the 3/8" by 9-1/2" notch in the base. Mark the long edge of the board 2-1/2" from one end. Make a crosscut into the edge, stopping about 3/4" into the board. Set the saw to the in-rip position and rip the width to 4-3/4" along the same edge as the stopped crosscut. Stop the ripcut where the two cuts intersect. Turn off the saw and remove the base piece. The base should now measure as shown.

Push Stick

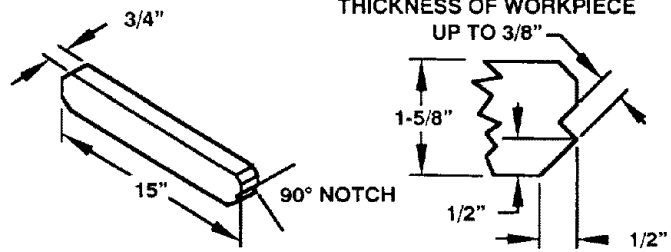

Material For Push Block

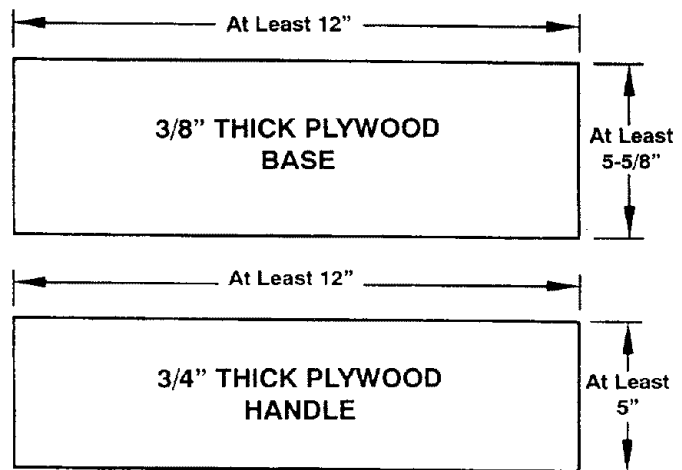

Cutting out the Base

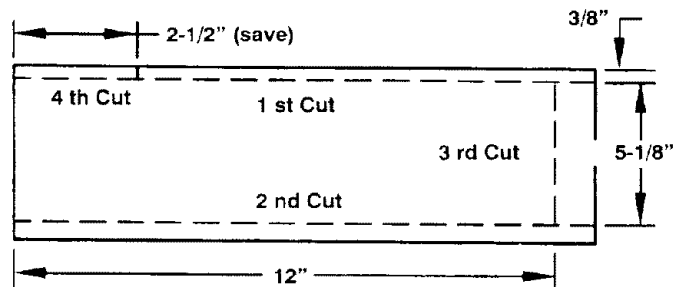

Creating the Notch

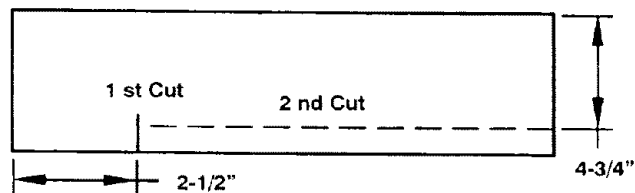

Finished Base

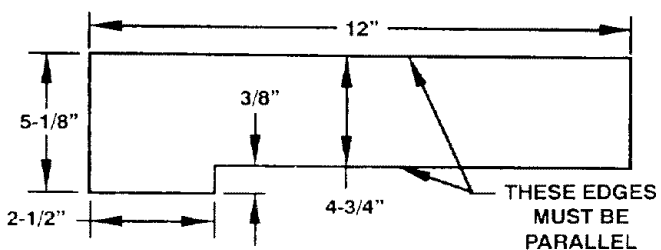

Cutting Aides

Making the Handle:

- Miter crosscut a piece of 3/4" thick plywood to the shape and size shown. The mitered corners can be any size that looks like the drawing (about 1-1/2" by 1-1/2").

Putting it together:

- Using good quality wood working glue, glue the 2-1/2" strip saved earlier to the base as shown. **Important:** Do not use nails or screws. This is to prevent dulling of the saw blade in the event you cut in to the push block.
- Position the handle at the edge of the plywood base as shown. Fasten them together with glue and wood screws. **Important:** Make sure the screw heads do not stick out from the bottom of the base. The bottom must be flat and smooth enough to slide along the auxiliary fence you are now ready to make.

Cutting out the handle

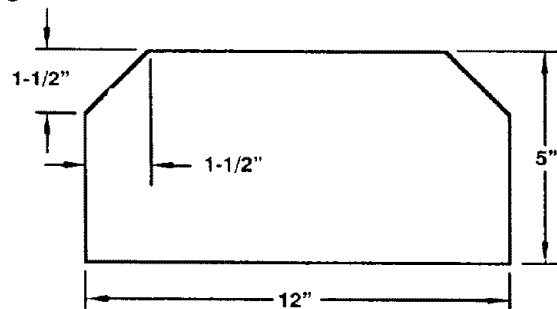

Assembly

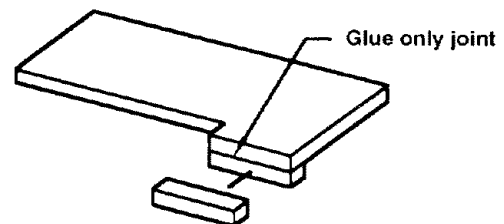

Auxiliary Fence:

Making the base:

- Start with a piece of 3/8" thick plywood at least 5-1/2" wide and at least 30" long.
- Cut the piece to 5-1/2" wide and 30" long.

Making the side pieces:

- Using 3/4" plywood at least 30" long, rip-out one piece 2-1/4" wide and one piece 3-1/4" wide.
- Separately, crosscut both pieces to 30" long.

Putting it together:

- Glue and then fasten with screws the side pieces to the base as shown. Make sure the edge of the base and the face of the side piece are parallel as indicated in the note next to the drawing. **Important:** Make sure the screw or nail heads do not stick out from the bottom of the base. The bottom must be flat and smooth enough to rest on the saw table without rocking.

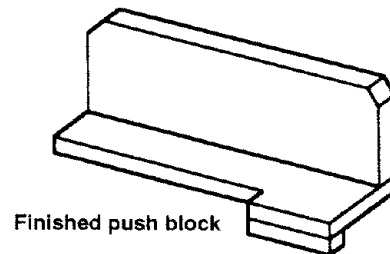
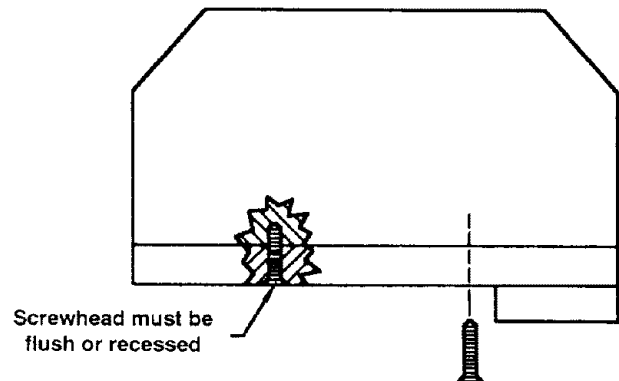

Auxiliary Fence

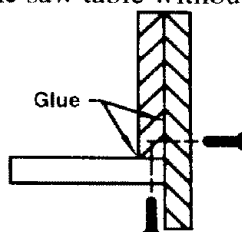
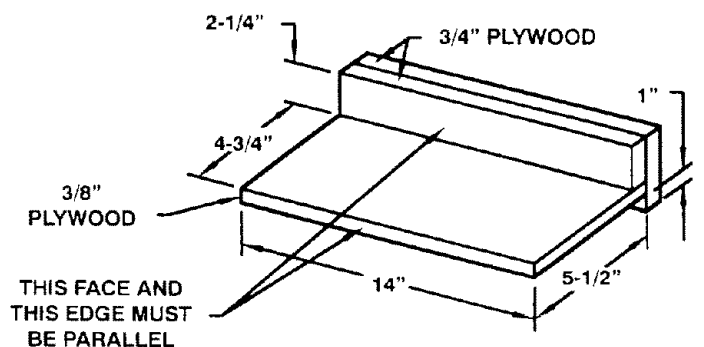

Use 2 screws in at least 2 equally spaced locations along fence (for a total of 4 screws)

Cutting Aides

Clamp the featherboard to the front table, so that the angled edge of the featherboard is against the workpiece on the infeed side of the blade. **Do not clamp the featherboard against the cut off part (out-feed side) of the workpiece.** If clamped to the outfeed side, the featherboard can squeeze the kerf closed, put binding pressure on the blade, and cause kickback.

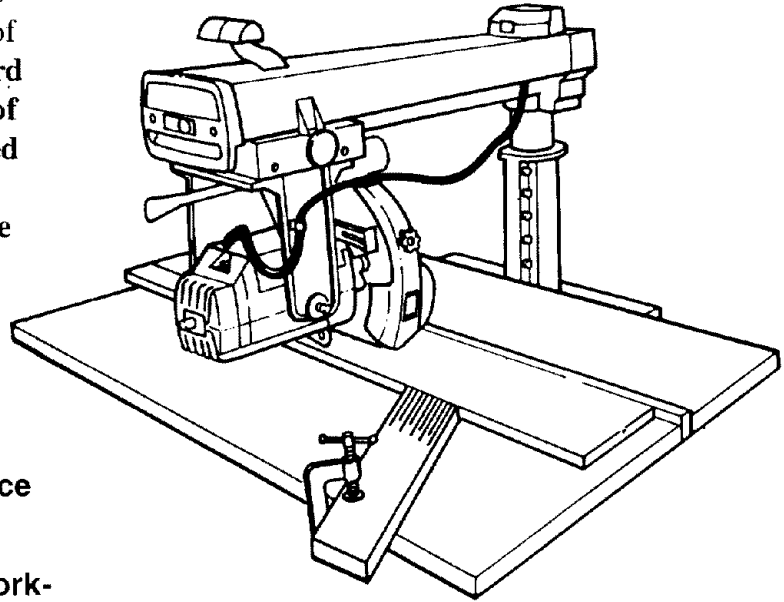

Straight Edge for Irregular Workpiece

WARNING

If you try to rip an irregular workpiece, it could bind blade and cause kickback.

If the workpiece you want to rip does not have a straight edge, attach a straight-edged board to the workpiece:

- a) place irregular side of workpiece against fence
- b) put straight-edged board on top of workpiece and against fence
- c) tack straight edged board to work piece.

Note: *Straight-edged board must not extend beyond leading end of workpiece and should cover workpiece width only enough to pass between blade and fence.*

Note: *Use fence at least as high as combined heights of workpiece and straight-edged board.*

Accessories Safety

1. Use only accessories listed in this section. Use of any other accessory or attachment might increase the risk of injury to you or others.
2. Read and follow instructions that come with accessory.
3. Do not install accessories on both ends of arbor shaft at same time.
4. Do not use twist drill bits longer than 7" because they can bend and break.
5. Use a spade type drill 1" or smaller in diameter for drilling only wood or plastic.
6. Do not use reduced shank drills.
7. Remove blade wrenches before turning saw on.

DANGER

Grinding wheels, abrasive or cut off wheels, or wire wheels can break explosively and throw pieces. You can be blinded or receive a life threatening puncture wound. Do not use grind wheels, abrasive or cut off wheels, or wire wheels.

WARNING

When using accessory shaft, exposed arbor shaft can pull in clothing, hair or jewelry as it rotates. Broken bones and severe cuts could occur.

Follow personal safety instructions. Locate arbor shaft under radial arm: lock blade carriage in out-rip position, then bevel motor to -90° .

Information for Dado

1. Put inside loose collar on arbor shaft first, then install dado. Tighten blade nut directly against outside surface of dado.
2. Saw arbor is designed for dado up to $13/16$ " wide. Use of wider dado could cause dado and blade nut to spin off. To make larger than $13/16$ " wide cut, take several passes with dado.
3. To avoid excessive load on motor when making a $13/16$ " wide cut, limit depth of cut to $1/8$ " in one pass.

Information for Edging

Edging is the use of a dado or molding head in the horizontal position. Edging requires the use of a molding head guard (see Accessories List)

1. Use molding head guard for edging with molding head and dado blade. Follow instructions that come with guard. Do not edge with a blade.

DANGER

Edging without a guard can bring hands and fingers too close to blade. Hands, fingers and arm could be cut off. Buy, install, and follow instructions for molding head guard.

WARNING

Blade cannot be guarded in horizontal position. Edge with guarded molding head or dado. Do not edge with blade.

2. Whenever possible, edge with arm locked at indexed 0° miter, so blade carriage is more likely to lock firmly.
3. Before edging, with saw unplugged and yellow key out, turn cutting tool by hand to make sure it does not strike guard or any other part of saw.

Accessories

Accessories for this Saw

These accessories are designed to fit this saw. Read and follow instructions that come with accessory.

Item.....	Catalog No.
-----------	-------------

Auxiliary Table Cover.....	see catalog
----------------------------	-------------

Blades (10" with 5/8" hole).....	see catalog
----------------------------------	-------------

Dado Blades

Adjustable Dado

7"-24 tooth carbide.....	see catalog
--------------------------	-------------

7"-32 tooth carbide.....	see catalog
--------------------------	-------------

7"-16 tooth carbide.....	see catalog
--------------------------	-------------

8"-48 tooth carbide.....	see catalog
--------------------------	-------------

Satin Cut Dado

7".....	see catalog
---------	-------------

8".....	see catalog
---------	-------------

8" carbide.....	see catalog
-----------------	-------------

Standard Cut Dado

8".....	see catalog
---------	-------------

Drill Chuck & Key.....	see catalog
------------------------	-------------

Dust Collector.....	9-29963
---------------------	---------

Extension Table.....	see catalog
----------------------	-------------

Leg Set Caster.....	9-22221 or 9-22222
---------------------	--------------------

Molding Heads

7" bits not included.....	see catalog
---------------------------	-------------

7"-27 piece set.....	see catalog
----------------------	-------------

7"-15 piece set.....	see catalog
----------------------	-------------

Sanding Wheel -10".....	see catalog
-------------------------	-------------

Sanding Drum.....	9-25246
-------------------	---------

Taper Jig.....	see catalog
----------------	-------------

Guards

Molding Head Guard -8".....	see catalog
-----------------------------	-------------

Accessory Lower Guard.....	9-29010
(supplied with saw)	

Books

Power Tool Know How Handbook.....	9-29114
-----------------------------------	---------

General Information

When new, the saw requires no lubrication. The saw has been partially aligned and all bearings are lubricated and sealed for life. In time, in order to keep the saw in good working order, it will be necessary to clean, lubricate and re-align.

WARNING

To avoid shock, burns, or lacerations from accidental start up of saw, turn power switch off and unplug saw before doing maintenance or servicing saw.

Cleaning

Periodically remove any heavy build-up of sawdust that may accumulate on the saw. The absorbing tendency of sawdust will draw lubricants away from the areas where they are needed. Wipe the carriage bearings and track surfaces with a dry or lightly oiled cloth.

To avoid motor damage due to sawdust build-up, which interferes with normal motor ventilation, vacuum the motor often.

Lubrication

Do not lubricate motor bearings, carriage bearings, or the area between the miter lock and the column tube. Motor and carriage bearings are sealed and do not need added lubrication.

Areas that should be lubricated periodically are the bevel index pin, swivel index pin, and column tube.

You can lubricate other points if necessary, but only when sticking or binding occurs. Use a small amount of SAE No. 10W30 automotive engine oil. Excess oil attracts air-borne dust and sawdust.

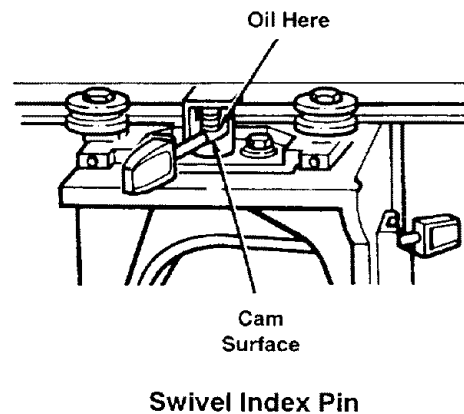
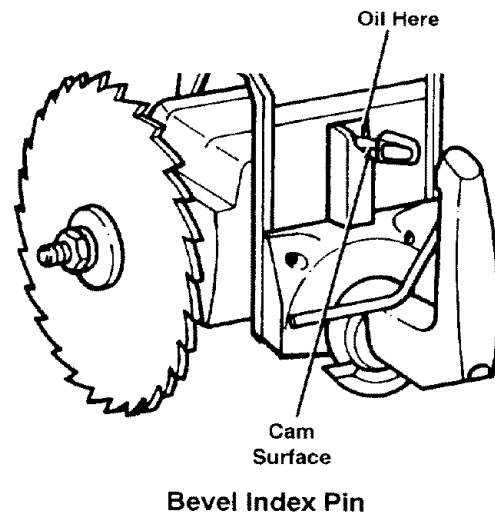

Apply a few drops of oil to top of pin and allow to flow down sides of pin. Move pin up and down in its housing to work the oil over side of pin.

Maintenance

Replacing Pawls

Make sure the teeth of the pawls are always sharp. If they become dull the pawls must be replaced:

1. Use 7/16" wrench to remove hex nut. Remove old pawls.
2. Install new pawls. Place spacers exactly as shown.
3. Re-install hex nut.
4. Check that pawls work freely.

Blade Changing

To change the saw blade:

1. Turn switch off, remove yellow key, and unplug saw.
2. Remove guard.
3. Use both blade wrenches in scissor action to loosen blade nut. Note: Arbor shaft has left-hand threads. Turn nut clockwise to loosen.
4. Remove nut, blade collar, and blade. Install new blade, making sure that arrow is on outside and points clockwise.
5. Re-install blade collar and nut. **Note:** Do not overtighten nut because this can cause blade collar to warp and blade to wobble during cutting.
6. Re-install guard.

Lubricating Blade Guard Assembly

If guard becomes difficult to raise:

1. Clean sawdust from the slot and slider.
2. Regrease with a small amount of light grease applied to the slot and slider. Also add a thin coat of grease between the Trigger and the Pull Link.

Adjusting the Trigger

If the Trigger becomes loose side-to-side, adjust the setscrews at the top of the Yoke Handle. Use a 1/8" hex wrench to tighten setscrews tight. Then back off one setscrew until the Trigger moves freely.

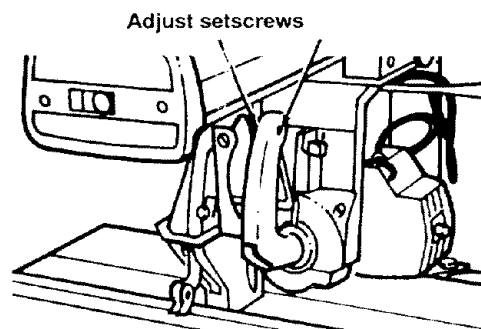
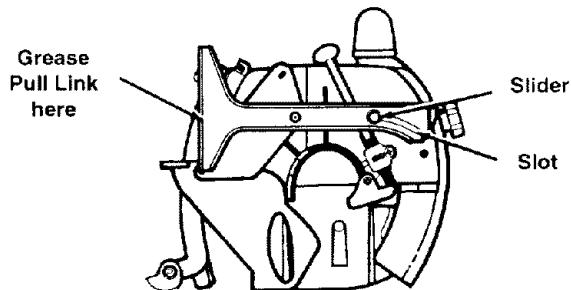
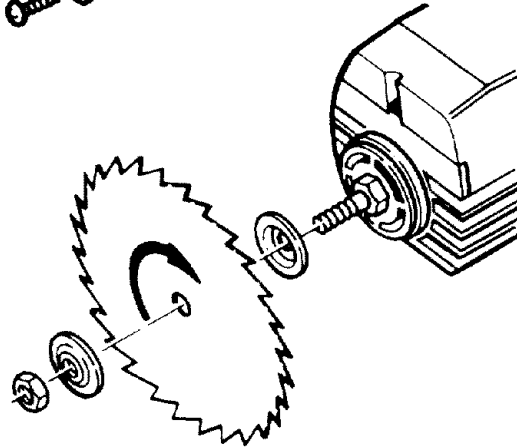
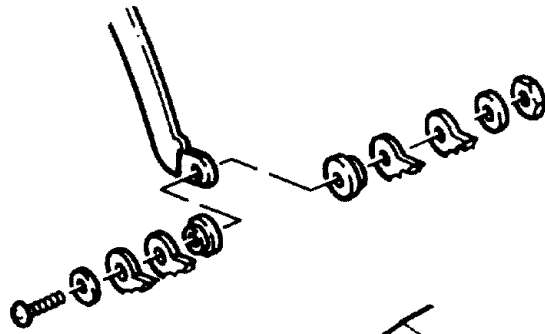

Troubleshooting

HAVE YOU FOLLOWED ALL STEPS OF THE ALIGNMENT PROCEDURE? IF YOU HAVE NOT FOLLOWED THEM IN THEIR PROPER SEQUENCE, YOU CANNOT EXPECT ACCURATE CUTTING RESULTS.

In addition to the proper alignment of your saw, you must also become familiar with the following practices in order to expect the best results.

1. Edge of workpiece which is placed against fence must be as straight as the long side of your framing square.
 2. Workpiece must be as flat as the front table board on your saw.
 3. There must be no sawdust or other wood chips between the fence and the front table board.
 4. There must be no sawdust or other wood chips underneath workpiece or between workpiece and fence.
 5. Workpiece must be held tightly against fence and down against the table...this is especially important when making angle cuts because the workpiece has a tendency to move.
 6. Always use the correct sawblade for the job...Always keep it sharp.
 7. When making a four sided frame:
 - a. The two side pieces must be exactly the same length.
 - b. The top and bottom pieces must be exactly the same length.
 - c. Always place the same edge of the workpiece against, the fence...turn the workpiece end for end for the successive cuts and mark a pencil line on the table for gauging the required length.
- Deviation from any of the above practices will have an effect on the accuracy of the cuts that you make.

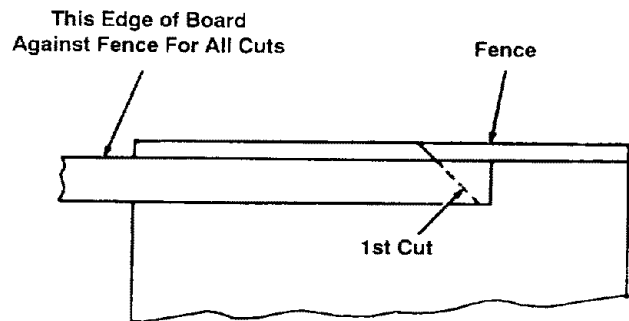

Turn Workpiece Over End For End...Keep Same Edge Against Fence When Making Successive Cuts.

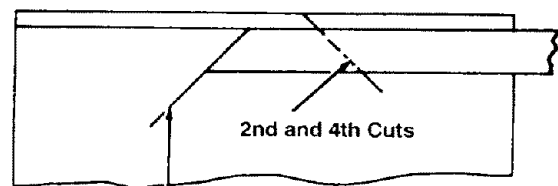

Pencil Line For Gauging Required Length

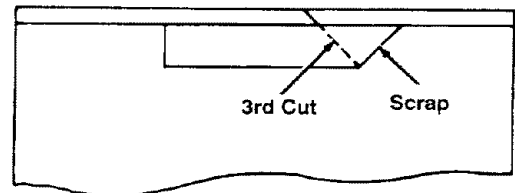

Troubleshooting

Motor Problem	Possible Cause(s)	What to Do
Motor overheats or stalls	Overloaded power line	Reduce line load by removing other lights, appliances
	Feeding rate too fast	Slow down rate of feed
	Improper motor cooling	Vacuum sawdust from motor to allow normal air circulation
	Saw blade has heel	Check alignment
	Saw blade is dull	Sharpen blade
While motor is running, fuses blow	Motor Overloaded	Slow down rate of feed
	Need 15 amp circuit	Call your electrician
	Need 15 amp slow-blow fuse	Install correct fuses
	Low voltage	Check voltage. Normal loads can be safely handled at 10% above or below nameplate voltage; heavy loads need same voltage at motor terminal as on nameplate
Motor starts slowly or fails to come to full power	Incorrect gauge extension cord	Refer to table in Electrical Connections
	Overloaded power line	Reduce line load by removing other lights, appliances
	Undersize wires or circuit too long	Increase wire size or shorten length of wiring
Motor will not run	Protector circuit open	Push re-set button; listen and feel for click
	Low voltage	Check power line for correct voltage
	Sawdust build-up	Vacuum motor
	Bent or bound-up arbor shaft	Check that shaft turns freely by hand; if it doesn't, contact Sears
Fuses blow when motor is turned on	Internal damage	Take saw to Sears for service

Troubleshooting

Cutting Problem	Possible Cause(s)	What to Do
Inaccurate cut	Loose locks	Check miter, rip, bevel, and swivel locks. See Adjustments section
	Saw blade out of alignment	Check alignment
Crosscuts not accurate at indexed miter positions	Sawdust between workpiece and fence	Keep front table clean
	Fence not straight	Replace fence
	Swivel lock loose or not locked	Adjust swivel lock for wear
	Crosscut travel not square with fence	Square blade crosscut travel
	Carriage assembly loose on arm	Adjust carriage bearings, then realign saw
	Arm not indexing properly	Adjust miter lock for wear
	Looseness between column tube and column support	Adjust column support
Depth of crosscut varies from one side of workpiece to other	Table not parallel with radial arm	Adjust table supports
Saw cuts at slight bevel	Blade not square to table	Square blade to table for crosscutting and ripping
	Table not parallel to radial arm	Adjust table supports
	Bevel lock loose	Adjust bevel lock
	Work table not flat	Adjust or replace table
	Carriage bearings loose	Adjust carriage bearings, then realign saw
Workpiece kerf rough with tooth marks from blade	Blade not square to fence	Square blade to fence
	Using improper blade for desired finish cut	Use proper smooth-cutting blade
Blade tends to advance through workpiece too fast during crosscutting	Blade dull	Sharpen or replace blade
	User pulls blade through workpiece too fast	Pull blade slowly and steadily through workpiece

Troubleshooting

Cutting Problem

Workpiece strikes riving knife during ripping

Possible Cause(s)

Riving knife not in line with blade

What to Do

Align riving knife to blade

Workpiece binds, smokes, and motor slows or stops when ripping

Saw blade out of alignment

Re-align

Warped workpiece

Do not cut severely warped pieces

Feed rate too fast

Slow feed rate

Carriage assembly loose

Adjust carriage bearings, then realign saw

Fence not straight

Replace fence

Dull or incorrect blade

Sharpen or replace blade

Board pulls away from fence during ripping

Saw blade out of alignment

Re-align

May occur as normal result of applying feed pressure

Use featherboard on infeed side

Saw Problem

Radial arm moves when locked in a non-indexed miter position

Possible Cause(s)

Miter not locked firmly

What to Do

Adjust miter lock for wear

Motor moves when bevel lock is locked

Bevel not locked firmly

Adjust bevel lock for wear

Yoke moves when rip lock is locked

Rip lock not locked firmly

Adjust rip lock for wear

Blade carriage does not travel smoothly on arm

Dirty track

Clean and lubricate track

Carriage bearings set too tight

Adjust carriage bearings, then realign saw

Rip lock rubbing track

Loosen Rip Lock

Worn steel track

Replace track

Bad carriage bearing

Replace carriage bearing

Blade does not stop spinning within 15 seconds after saw is turned off

Blade nut loose

Tighten blade nut

Internal damage

Take saw back to Sears for service

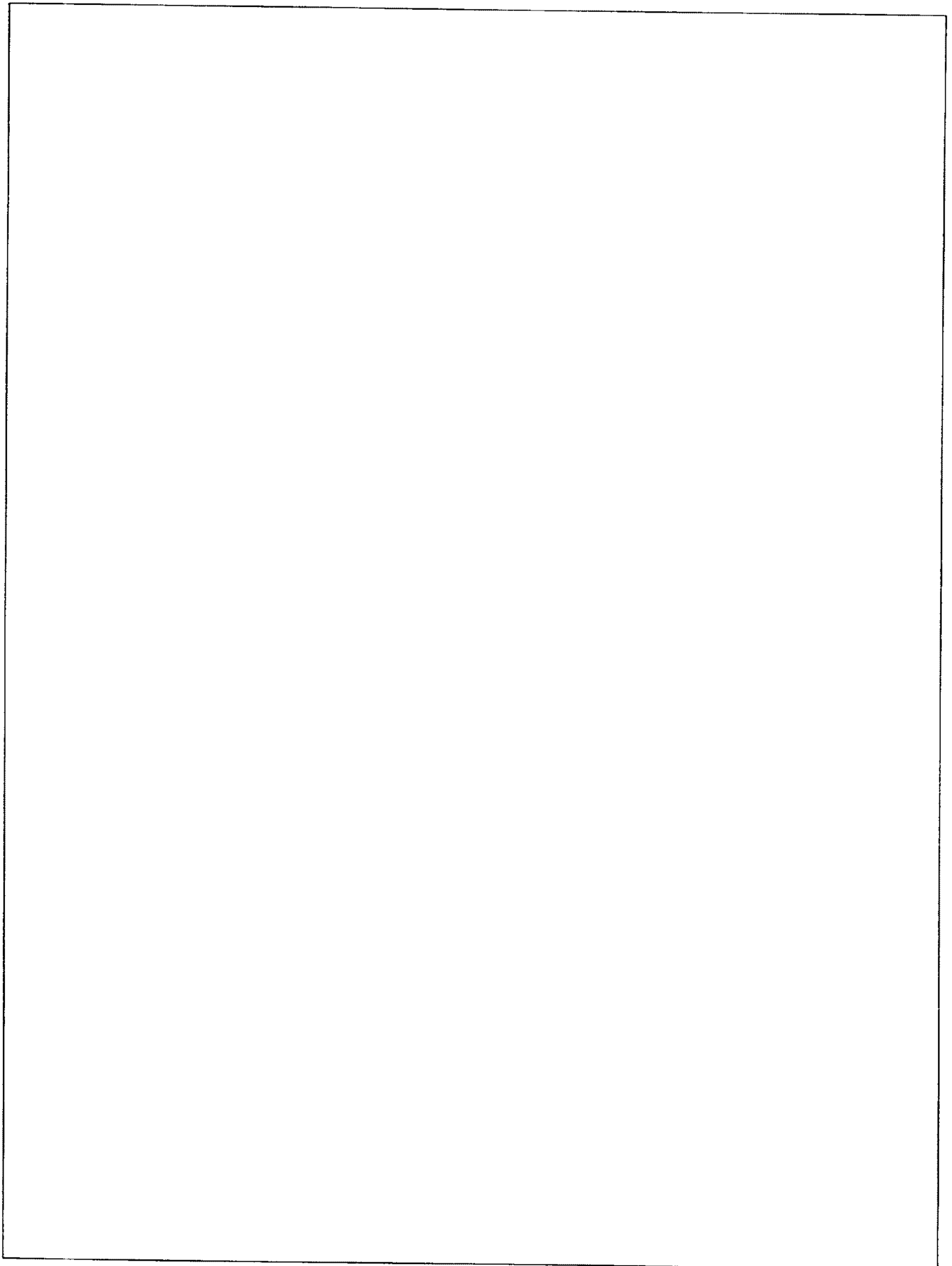

**PARTS LIST FOR CRAFTSMAN 10" RADIAL SAW
MODEL NUMBER 113.196380**

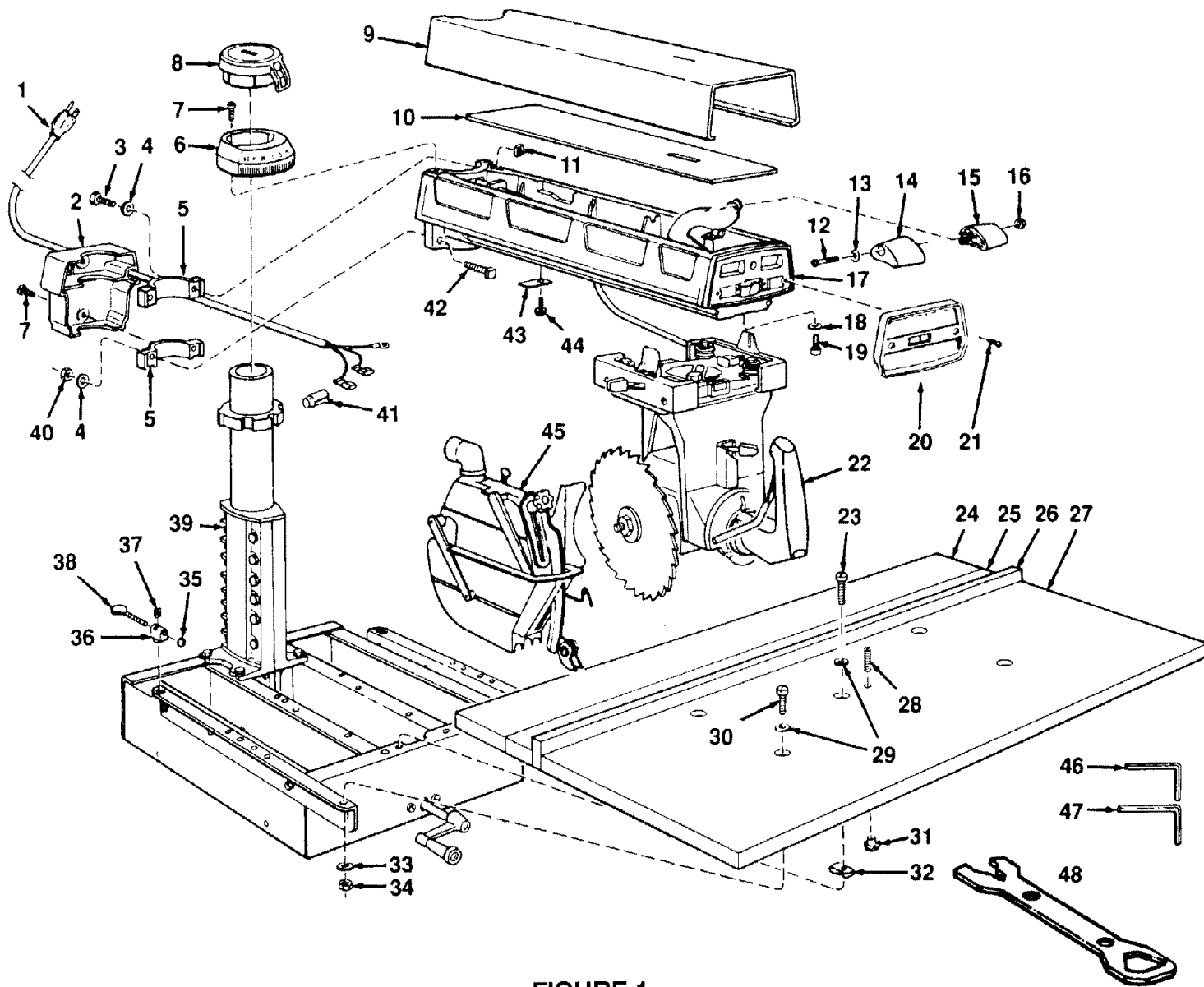

FIGURE 1

**PARTS LIST FOR CRAFTSMAN 10" RADIAL SAW
MODEL NUMBER 113.196380**

Always order by Part Number - Not by Key Number

FIGURE 1

Key No	Part No.	Description
1	63518	Cord, with Plug
2	75090	Cover, Rear Arm
3	60339	Screw, Hex Hd Locking, 3/8-16 x 2-1/8 High Strength
4	60353	Washer, .380 x 47/64 x 1/8
5	815649	Bearing, Arm
6	63669	Scale, Miter
7	STD601105	* Screw, Pan Rec. Hd 10-32 x 3/8
8	63670	Indicator, Miter
9	824962	Trim Arm
10	63686	Pad, Arm Trim
11	805494	Nut, Square 3/8-16
12	436594	* Screw, Pan Rec. Hd 10-32 x 1-1/2
13	STD551010	* Washer, 13/64 x 7/16 x 1/16
14	63884	Knob, L.H. Lever Arm
15	63885	Knob, R.H. Lever Arm
16	STD541110	* Nut, Hex 10/32
17	-	Arm Assembly, See Fig. 5
18	STD551131	* Lockwasher, 5/16
19	9421620	Screw, Soc. Hd Cap 5/16-18 x 1/2
20	821473-3	Cap, Arm
21	60337	Screw, Type "T" Pan Hd 10/32 x 7/8
22	-	Yoke Assembly, See Fig. 2
23	STD512520	* Screw, Pan Hd 1/4-20 x 1-3/4
24	821367	Table, Rear

Key No	Part No.	Description
25	821368	Table, Spacer
26	63432	Fence, Rip
27	821366	Table, Front
28	102711	Screw, Set SL. Cup 1/4-20 x 1
29	STD551012	* Washer, 17/64 x 5/8 x 1/32
30	STD512510	* Screw, Pan Hd 1/4-20 x 1
31	37384	Nut, Tee
32	37530	Nut, "U" Clip
33	STD551125	* Lockwasher, 1/4
34	STD541025	Nut, Hex 1/4-20
35	818161	Shoe, Table Clamp
36	818166	Bracket, Clamp
37	120399	Nut, Square 5/16 - 18
38	818162	Screw, Clamp
39	-	Base Assembly, See Fig. 3
40	STD541437	* Nut, Lock 3/8-16
41	63467	Cap, Flag Terminal
42	60342	Bolt, Sq. Hd 3/8-16 x 2-1/4
43	63881	Clamp, Cord
44	9420417	Screw, Type "T" Hex Washer Hd 1/4-20 x 5/8
45	-	Guard Assembly, See Fig. 4
46	63683	Wrench, Hex "L" 3/16
47	63682	Wrench, Hex "L" 1/4
48	3540	Wrench
-	SP5976	Owners Manual (Not Illustrated)

* Standard Hardware Item - May Be Purchased Locally.

Repair Parts

PARTS LIST FOR CRAFTSMAN 10" RADIAL SAW MODEL NUMBER 113.196380

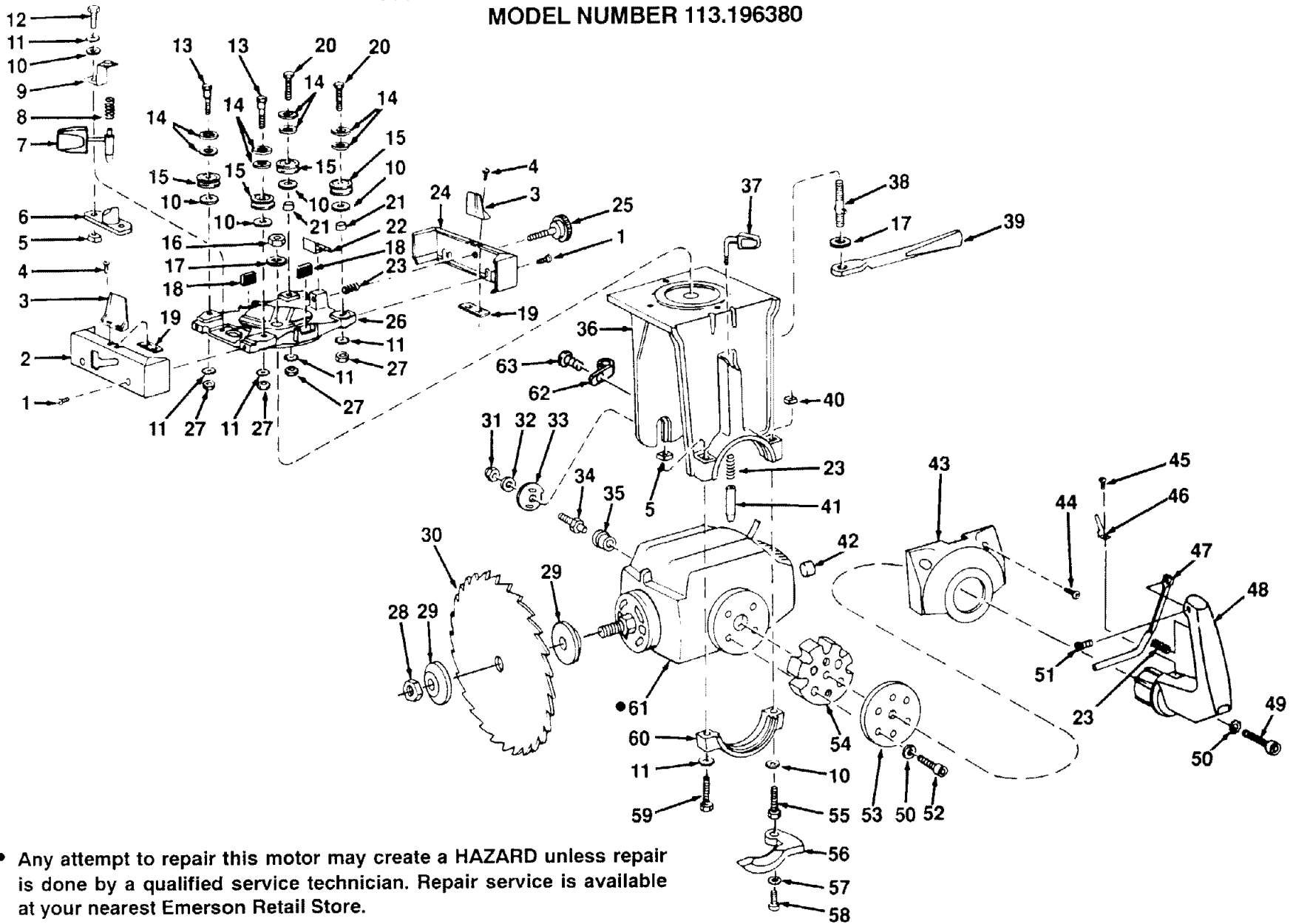

• Any attempt to repair this motor may create a HAZARD unless repair is done by a qualified service technician. Repair service is available at your nearest Emerson Retail Store.

FIGURE 2

**PARTS LIST FOR CRAFTSMAN 10" RADIAL SAW
MODEL NUMBER 113.196380
FIGURE 2 – YOKE ASSEMBLY**

Key No	Part No.	Description
1	STD601105	* Screw, Type "T" Pan Rec. Hd 10-32 x 1/2
2	63661	Cover, L.H. Carriage
3	63786	Indicator, Rip
4	STD510605	* Screw, Pan Rec. Hd 6-32 x 1/2
5	120399	Nut, Square 5/16-18
6	63657	Housing, Index Pin
7	63893	Pin Assembly, Index
8	63658	Spring, Index
9	63656	Bracket, Spring
10	STD551031	* Washer, 21/64 x 3/4 x 1/16
11	STD551231	* Lockwasher, 5/16, Ext. Tooth
12	STD523107	* Screw, Hex Hd 5/16-18 x 3/4
13	63778	Screw, Eccentric
14	63782	Washer Assembly, Carriage Bearing
15	63777	Bearing, Carriage
16	STD541462	* Nut, Lock 5/8-11
17	STD551062	* Washer, .630 x 1.125 x .093
18	30567	Bumper
19	30530	Nut, Speed
20	60336	Bolt, Hex Hd 5/16-18 x 1-1/2 High Strength
21	63779	Bearing, Sleeve
22	63528	Shoe, Rip Lock
23	30521	Spring, Swivel Latch
24	63659	Cover, R.H. Carriage
25	63660	Knob, Carriage Lock
26	63641	Carriage
27	STD541231	* Nut Hex Jam 5/16-18
28	30495	Nut, Shaft
29	62498	Collar
30	9-28875	† Blade, Saw
31	STD541437	* Nut, Lock 3/8-16
32	STD551037	* Washer, .380 x 47/64 x 1/16
33	63652	Cam, Motor

Key No	Part No.	Description
34	63651	Stud, Motor
35	63469	Bushing, Rubber
36	63642	Yoke
37	63648	Knob, Bevel Index
38	63643	Stud, Yoke Clamp
39	63644	Handle, Yoke Lock
40	60333	Nut, Square L.H. 5/16-18
41	63645	Pin, Index
42	30582	Cap, Shaft
43	63620	Trim, Yoke
44	60337	* Screw, Type "T" Pan Rec. Hd 10-32 x 7/8
45	STD600803	* Screw, Type "T" Pan Rec. Hd 8/32 x 5/16
46	63662	Indicator, Bevel
47	821354	Trigger
48	821342	Handle, Yoke
49	9421628	Screw, Soc. Cap 5/16-18 x 2
50	STD551131	* Lockwasher, 5/16
51	60288	Screw, Set 1/4 - 20 x 3/8
52	9421627	Screw, Soc. Cap 5/16-18 x 1-5/8
53	63650	Plate, Retainer
54	63649	Ring, Index
55	60335	Screw, Hex Hd L.H. 5/16-18 x 2
56	63647	Lever, Bevel Lock
57	STD551210	* Lockwasher, Ext. Tooth No. 10
58	806214	Screw, Hex Soc. Button Hd Cap 10-32 x 5/8
59	STD523120	* Screw, Hex Hd 5/16-18 x 2
60	63646	Cap, Yoke
61	821506	* Motor
62	30613	Clamp, Cord
63	STD600805	Screw, Pan TY "T" 8-32 x 1/2

* Standard Hardware Item – May Be Purchased Locally.
† Stock item – May be secured through the hardware departments of most Sears Retail Stores.

• Any attempt to repair this motor may create a HAZARD unless repair is done by a qualified service technician. Repair service is available at your nearest Sears Store.

Repair Parts

PARTS LIST FOR CRAFTSMAN 10" RADIAL SAW
MODEL NUMBER 113.196380

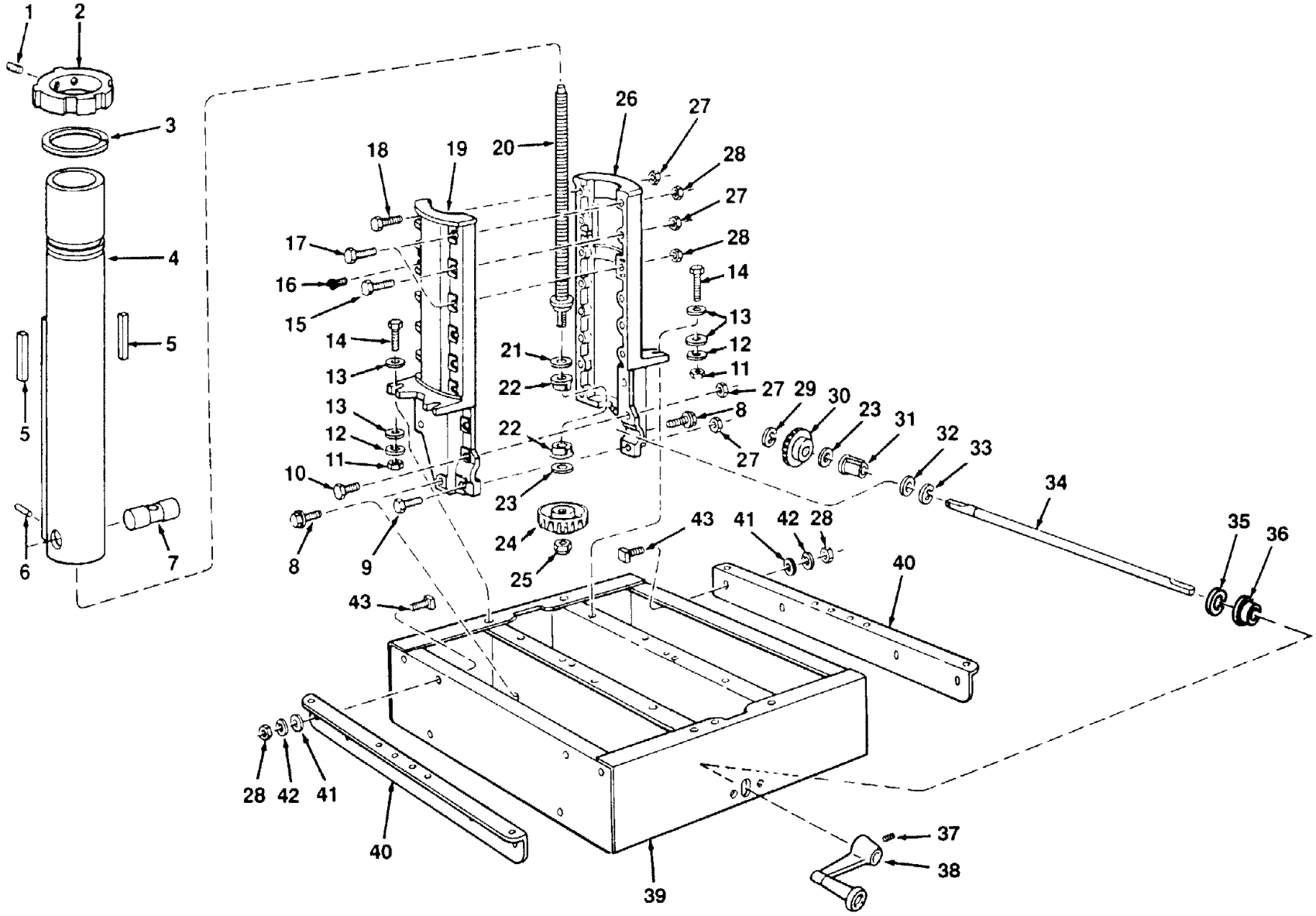

FIGURE 3

**PARTS LIST FOR CRAFTSMAN 10" RADIAL SAW
MODEL NUMBER 113.196380**

Always order by Part Number - Not by Key Number

FIGURE – 3 BASE ASSEMBLY

Key No	Part No.	Description
1	STD503705	* Screw, Soc. Set 3/8-16 x 1/2
2	63623	Latch, Arm
3	60330	Ring, Retaining 3"
4	63611	Tube
5	63610	Gib, Column Tube
6	STD572510	* Pin, Roll 1/4 x 1
7	821346	Nut, Elevation
8	9416187	* Screw, Type "T" Hex Washer Hd. 5/16-18 x 3/4
9	STD523110	* Screw, Hex Hd. 5/16-18 x 1
10	60078	* Screw, Hex Hd. 5/16-18 x 1/2
11	STD541037	* Nut, Hex 3/8-16
12	STD551137	* Lockwasher, 3/8
13	60340	* Washer, .380 x 7/8 x 1/8
14	STD523712	* Screw, Hex Hd. 3/8-16 x 1-1/4
15	186648	* Screw, Hex Hd. 5/16-18 x 1-7/8
16	817398-1	Screw, Locking Cap 1/4-20 x 5/8
17	60367	Bolt, Hex Hd. 5/16-18 x 1-7/8 High Strength
18	60336	Bolt, Hex Hd. 5/16-18 x 1-1/2 High Strength
19	63609	Support, L.H.
20	821348	Shaft, Elevating
21	63500	Washer, Thrust .502 x .927 x .031

Key No	Part No.	Description
22	63614	Bearing
23	60300	Washer, 1/2 x 7/8 x .010 (as required)
24	818164	Gear, Bevel
25	STD541450	* Nut, Lock 1/2-13
26	63619	Support, R.H.
27	STD541031	* Nut, Hex 5/16-18
28	STD541431	* Nut, Lock 5/16-18
29	STD581037	* Ring, Retaining 3/8
30	818165	Gear, Pinion
31	63617	Bearing, Elevating Shaft
32	STD551050	* Washer, .515 x .875 x .032
33	STD581050	* Ring, Retaining 1/2
34	821333	Shaft, Elevating Crank
35	STD581062	* Ring Retaining
36	63435	Bushing
37	STD502503	* Screw, Soc. Set 1/4-20 x 3/8
38	63434	Crank, Elevating
39	63621	Base
40	818199	Channel, Table Mounting
41	STD551031	* Washer, 11/32 x 7/8 x 1/16
42	STD551131	* Lockwasher, 5/16
43	109163	* Bolt, Square Hd 5/16-18 x 3/4

* Standard Hardware Item – May Be Purchased Locally.

Repair Parts

**PARTS LIST FOR CRAFTSMAN 10" RADIAL SAW
MODEL NUMBER 113.196380**

Always order by Part Number - Not by Key Number

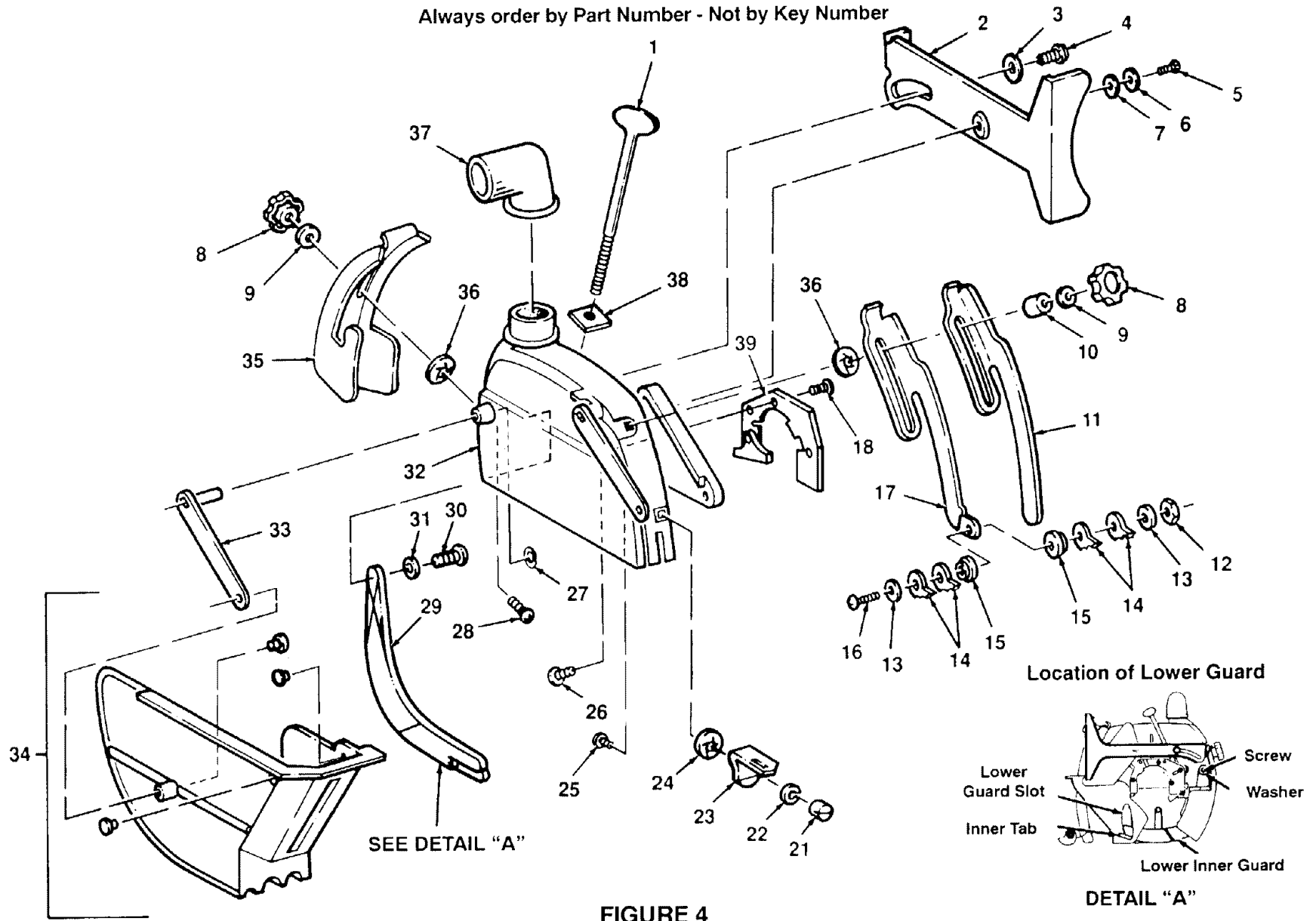

FIGURE 4

**PARTS LIST FOR CRAFTSMAN 10" RADIAL SAW
MODEL NUMBER 113.196380**

Always order by Part Number - Not by Key Number

FIGURE 4 – GUARD

Key No	Part No.	Description
1	821217	Screw, Guard Clamp
2	821313	Link, Pull
3	STD551012	* Washer, 17/64 x 5/8 x 1/16
4	815865	Screw, Hex Washer Hd Type "TT" 1/4 - 20 x 1/2
5	STD601105	* Screw, Pan Hd Type "TT" 10-32 x 5
6	802392-47	Spacer #10 x .125
7	808447-6	Washer, Spring
8	820529	Knob, 5/16-18
9	STD551031	* Washer 21/64 x 5/8 x 1/16
10	820521	Spacer
11	820515	Knife, Riving
12	STD541425	* Nut, Lock 1/4-20
13	STD551025	* Washer 17/64 x 5/8 x 1/16
14	815815	Pawl, AKB
15	820517	Bushing
16	STD512510	* Screw, Pan Hd. 1/4-20 x 1
17	820512	Holder, AKB
18	824159	Screw, Flat Hd Type "TT" 1/4 - 20 x 9/16

Key No	Part No.	Description
21	820519	Nut, Slotted 1/4 - 20
22	STD551225	* Lockwasher 1/4
23	820530	Support, Knife
24	808822-1	Nut, Push 1/4
25	820532	Bolt
26	809019-4	Bolt, Rd Hd Short Neck 5/16 - 18 x 1-3/4
27	805641-1	Ring, Retaining
28	STD533107	* Bolt, R.H. Short Neck 5/16 - 18 x 5/8
29	820985	Lower, Inner Guard
30	808380	Scr Plastite #8-16 x 1/2
31	805548-10	Washer 3/16
32	821312	Guard
33	821311	Link
34	821310	Guard, Lower
35	821314	Hold Down
36	60413	Nut, Push 5/16
37	63258	Elbow, Dust
38	821449	Nut, Square 5/16 - 18 Double
39	824158	Strap-Retainer

* Standard Hardware Item – May Be Purchased Locally.

Repair Parts

Repair Parts

PARTS LIST FOR CRAFTSMAN 10" RADIAL SAW MODEL NUMBER 113.196380

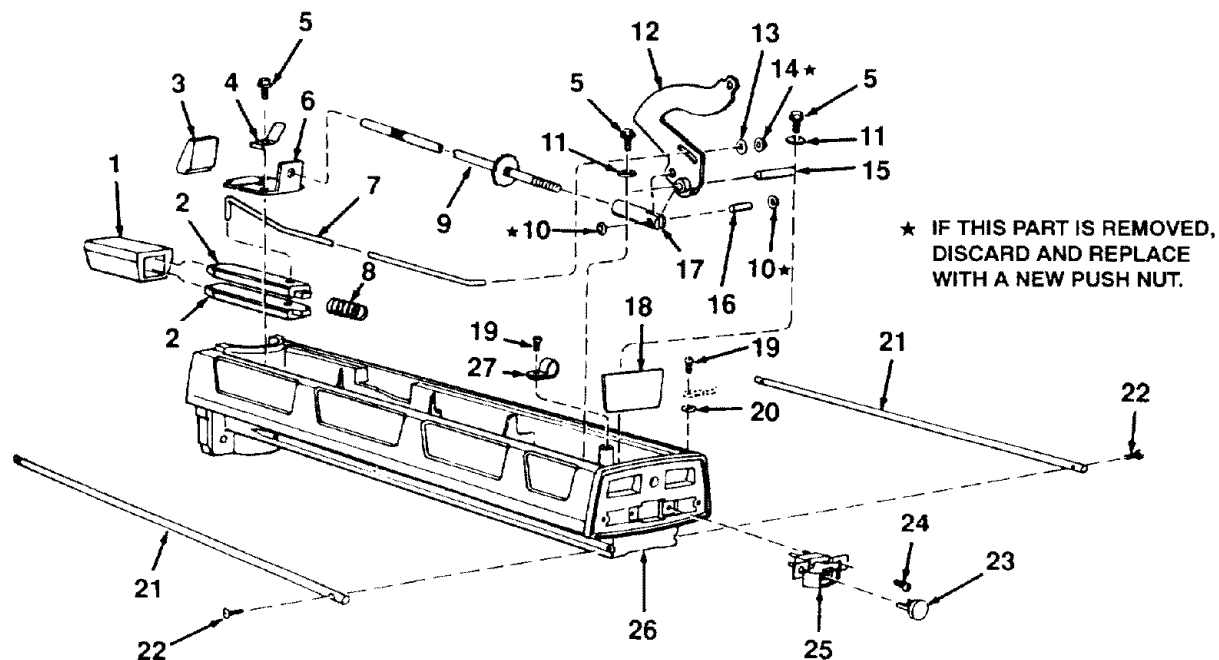

FIGURE 5 – ARM ASSEMBLY

Key No	Part No.	Description	Key No	Part No.	Description
1	63626	Housing, Pin	16	63637	Pin
2	63629	Pin, Arm Index	17	63636	Pin, Clevis
3	63631	Pawl, Arm Lock	18	63773	Insulation
4	63628	Spring, Tension	19	STD601103	* Screw, Type "T" Pan Hd 10-32 x 3/8
5	9420417	* Screw, Type "T" Hex Washer Hd 1/4-20 x 5/8	20	STD551210	* Lockwasher, Ext. Tooth N10
6	63883	Guide	21	63639	Track
7	63632	Rod, Index	22	448337	Screw, Type "T" Rd. Hd 10-32 x 5/8
8	63630	Spring, Arm Lock	23	9-22255	† Key
9	63633	Rod, Arm Lock	24	STD600805	* Screw, Type "T" Pan Hd 8-32 x 1/2
10	60240	★ Nut, Push 3/8	25	63896	Switch, Locking (Includes Key No. 23)
11	STD551031	* Washer, 21/64 x 1 x 1/8	26	63878	Arm, Radial
12	63872	Lever, Arm Lock	27	60440	Clamp, Cord
13	STD551012	* Washer, 17/64 x 5/8 x 1/32			
14	60208	* Nut, Push 1/4			
15	63638	Pin, Lever			

* Standard Hardware Item may be Purchased Locally.

★ If this part is removed, discard and replace with a new Push Nut.

Repair Parts

PARTS LIST FOR CRAFTSMAN 10" RADIAL SAW MODEL NUMBER 113.196380

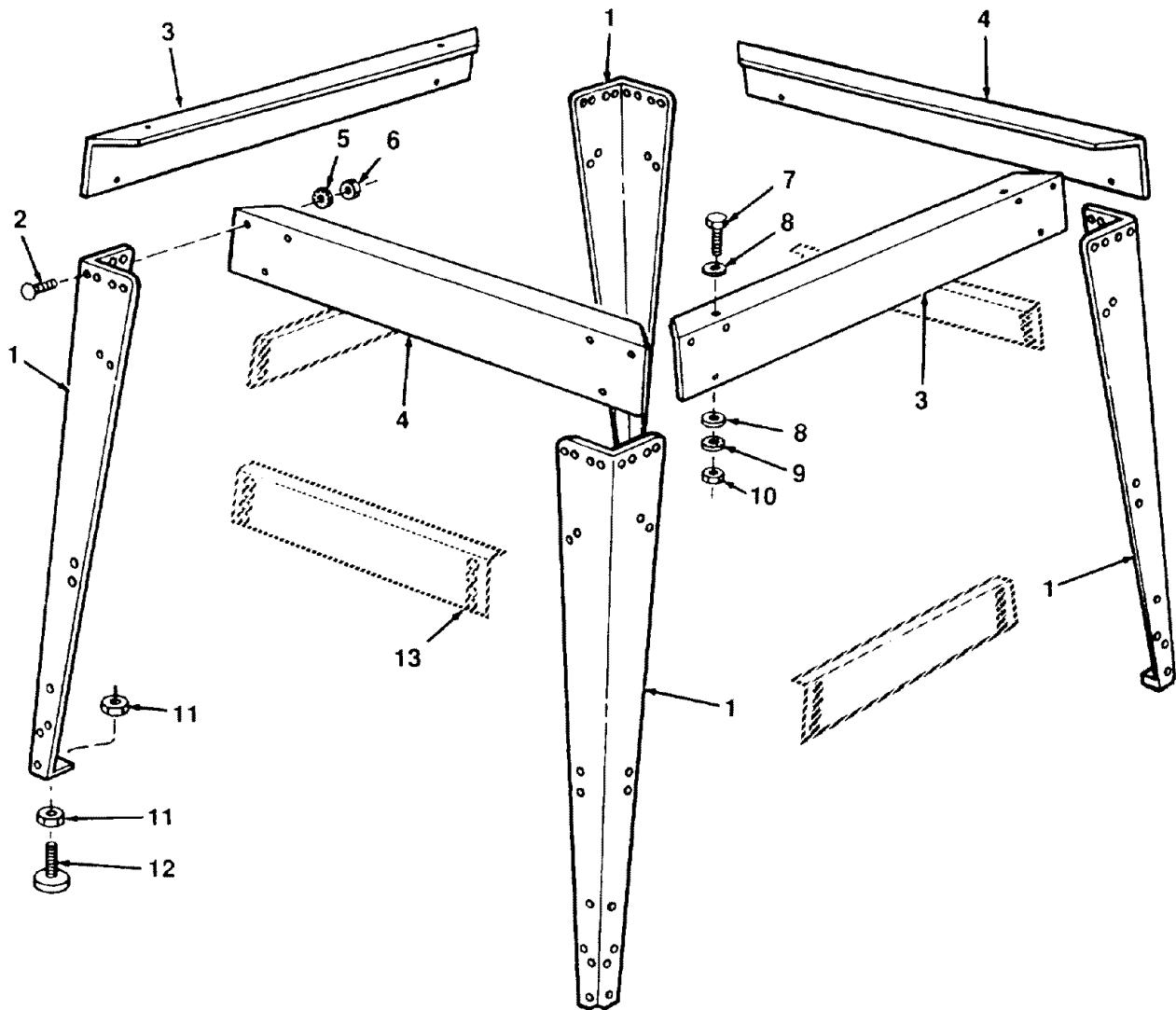

FIGURE 6 - LEG SET

Key No	Part No.	Description
1	821343	Leg
2	60314	Screw, Truss Hd. 1/4-20 X 5/8
3	821779	Stiffener, Side
4	821780	Stiffener, Front/Rear
5	STD551225	* Lockwasher, External 1/4
6	STD541025	* Nut, Hex 1/4-20
7	STD523106	* Screw, Hex Hd 5/16-18 x 5/8

Key No	Part No.	Description
8	STD551031	* Washer, 11/32 x 11/16 x 1/16
9	STD551131	* Lockwasher, External 5/16
10	STD541231	* Nut, Hex Jam 5/16-18
11	STD541037	* Nut, Hex 3/8-16
12	803835-1	Foot, Leveling
13	821360	• Lower Stiffener

- * Standard Hardware Item may be Purchased Locally.
- Part is not supplied with tool but is available through the service department.

SEARS

owner's manual

SERVICE

MODEL NO.
113.196380

The model number of your 10-Inch Radial saw is found at the front of the base.

When requesting service or ordering parts, always provide the following information:

- Product Type
- Model Number
- Part Number
- Part Description

10-INCH RADIAL SAW

For the repair or replacement parts you need

Call 7 am - 7 pm, 7 days a week

1-800-366-PART

(1-800-366-7278)

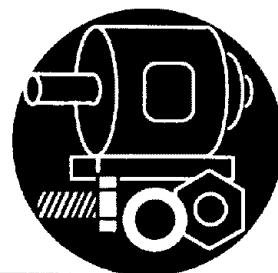

For in-home major brand repair service

Call 24 hours a day, 7 days a week

1-800-4-REPAIR

(1-800-473-7247)



For the location of a
Sears Repair Service Center in your area

Call 24 hours a day, 7 days a week

1-800-488-1222



For information on purchasing a Sears
Maintenance Agreement or to inquire
about an existing Agreement

Call 9 am - 5 pm, Monday-Saturday

1-800-827-6655



SEARS
REPAIR SERVICES

America's Repair Specialists

Sears Roebuck and Co., Hoffman Estates, IL 60179 U.S.A.

Part No. SP5976

Form No. SP5976-1

Printed in U.S.A. 11/96