

SEARS

CRAFTSMAN[®]

MODEL NUMBER 917.251561 OWNER'S MANUAL

- Assembly
- Operation
- Customer Responsibilities
- Service and Adjustments
- Repair Parts

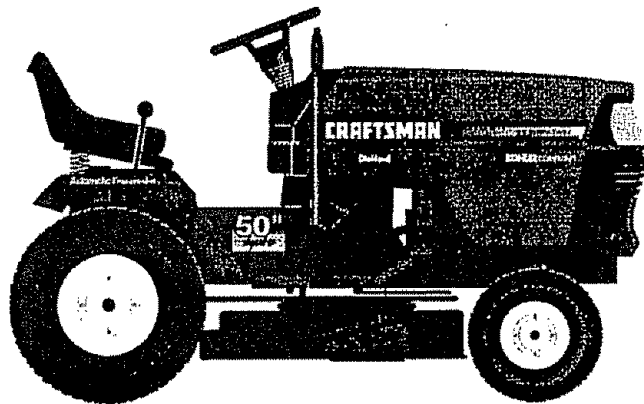

CAUTION: Read and follow all safety rules and instructions before operating this equipment.
FOR CONSUMER ASSISTANCE HOT LINE, CALL THIS TOLL FREE NUMBER: 1-800-659-5917

Sears, Roebuck and Co., Hoffman Estates, IL 60179 U.S.A.



SAFETY RULES



Safe Operation Practices for Ride-On Mowers

IMPORTANT: THIS CUTTING MACHINE IS CAPABLE OF AMPUTATING HANDS AND FEET AND THROWING OBJECTS. FAILURE TO OBSERVE THE FOLLOWING SAFETY INSTRUCTIONS COULD RESULT IN SERIOUS INJURY OR DEATH.

I. GENERAL OPERATION

- Read, understand, and follow all instructions in the manual and on the machine before starting
- Only allow responsible adults, who are familiar with the instructions, to operate the machine.
- Clear the area of objects such as rocks, toys, wire, etc., which could be picked up and thrown by the blade
- Be sure the area is clear of other people before mowing. Stop machine if anyone enters the area
- Never carry passengers.
- Do not mow in reverse unless absolutely necessary. Always look down and behind before and while backing
- Be aware of the mower discharge direction and do not point it at anyone. Do not operate the mower without either the entire grass catcher or the guard in place
- Slow down before turning.
- Never leave a running machine unattended. Always turn off blades, set parking brake, stop engine, and remove keys before dismounting.
- Turn off blades when not mowing.
- Stop engine before removing grass catcher or unclogging chute.
- Mow only in daylight or good artificial light
- Do not operate the machine while under the influence of alcohol or drugs.
- Watch for traffic when operating near or crossing roadways.
- Use extra care when loading or unloading the machine into a trailer or truck

II. SLOPE OPERATION

Slopes are a major factor related to loss-of-control and tipover accidents, which can result in severe injury or death. All slopes require extra caution. If you cannot back up the slope or if you feel uneasy on it, do not mow it

DO:

- Mow up and down slopes, not across.
- Remove obstacles such as rocks, tree limbs, etc
- Watch for holes, ruts, or bumps. Uneven terrain could overturn the machine. *Tall grass can hide obstacles.*
- Use slow speed. Choose a low gear so that you will not have to stop or shift while on the slope.
- Follow the manufacturer's recommendations for wheel weights or counterweights to improve stability.
- Use extra care with grass catchers or other attachments. These can change the stability of the machine
- Keep all movement on the slopes *slow* and *gradual*. Do not make sudden changes in speed or direction
- Avoid starting or stopping on a slope. If tires lose traction, disengage the blades and proceed slowly *straight* down the slope.

DO NOT:

- Do not turn on slopes unless necessary, and then, turn slowly and gradually downhill, if possible
- Do not mow near drop-offs, ditches, or embankments. The mower could suddenly turn over if a wheel is over the edge of a cliff or ditch, or if an edge caves in.
- Do not mow on wet grass. Reduced traction could cause sliding.
- Do not try to stabilize the machine by putting your foot on the ground
- Do not use grass catcher on steep slopes.

III. CHILDREN

Tragic accidents can occur if the operator is not alert to the presence of children. Children are often attracted to the machine and the mowing activity. *Never* assume that children will remain where you last saw them.

- Keep children out of the mowing area and under the watchful care of another responsible adult.
- Be alert and turn machine off if children enter the area.
- Before and when backing, look behind and *down* for small children.
- Never carry children. They may fall off and be seriously injured or interfere with safe machine operation
- Never allow children to operate the machine.
- Use extra care when approaching blind corners, shrubs, trees, or other objects that may obscure vision.

IV. SERVICE

- Use extra care in handling gasoline and other fuels. They are flammable and vapors are explosive.
 - Use only an approved container.
 - Never remove gas cap or add fuel with the engine running. Allow engine to cool before refueling. Do not smoke.
 - Never refuel the machine indoors.
 - Never store the machine or fuel container inside where there is an open flame, such as a water heater.
- Never run a machine inside a closed area.
- Keep nuts and bolts, especially blade attachment bolts, tight and keep equipment in good condition.
- Never tamper with safety devices. Check their proper operation regularly.
- Keep machine free of grass, leaves, or other debris build-up. Clean oil or fuel spillage. Allow machine to cool before storing.
- Stop and inspect the equipment if you strike an object. Repair, if necessary, before restarting.
- Never make adjustments or repairs with the engine running.
- Grass catcher components are subject to wear, damage, and deterioration, which could expose moving parts or allow objects to be thrown. Frequently check components and replace with manufacturer's recommended parts, when necessary.
- Mower blades are sharp and can cut. Wrap the blade(s) or wear gloves, and use extra caution when servicing them.
- Check brake operation frequently. Adjust and service as required.



Look for this symbol to point out important safety precautions. It means CAUTION!!! BECOME ALERT!!! YOUR SAFETY IS INVOLVED.



CAUTION: Always disconnect spark plug wire and place wire where it cannot contact spark plug in order to prevent accidental starting when setting up, transporting, adjusting or making repairs.

⚠ WARNING ⚠

The engine exhaust from this product contains chemicals known to the State of California to cause cancer, birth defects, or other reproductive harm.

SUGGESTED GUIDE FOR SIGHTING SLOPES FOR SAFE OPERATION

CONGRATULATIONS on your purchase of a Sears Tractor. It has been designed, engineered and manufactured to give you the best possible dependability and performance.

Should you experience any problem you cannot easily remedy, please contact your nearest Sears Authorized Service Center/Department. We have competent, well-trained technicians and the proper tools to service or repair this tractor.

Please read and retain this manual. The instructions will enable you to assemble and maintain your tractor properly. Always observe the "SAFETY RULES"

MODEL NUMBER	917 251561
SERIAL NUMBER	_____
DATE OF PURCHASE	_____
THE MODEL AND SERIAL NUMBERS WILL BE FOUND ON A PLATE UNDER THE SEAT	
YOU SHOULD RECORD BOTH SERIAL NUMBER AND DATE OF PURCHASE AND KEEP IN A SAFE PLACE FOR FUTURE REFERENCE.	

MAINTENANCE AGREEMENT

A Sears Maintenance Agreement is available on this product. Contact your nearest Sears store for details.

CUSTOMER RESPONSIBILITIES

- Read and observe the safety rules
- Follow a regular schedule in maintaining, caring for and using your tractor.
- Follow the instructions under "Customer Responsibilities" and "Storage" sections of this owner's manual

PRODUCT SPECIFICATIONS

HORSEPOWER:	22.5
GASOLINE CAPACITY AND TYPE:	3.5 GALLONS UNLEADED REGULAR
OIL TYPE (API-SF/SG):	SAE 10W30 (above 32°F) SAE 5W-30 (below 32°F)
OIL CAPACITY:	W/ FILTER: 4.2 PINTS W/O FILTER: 3.7 PINTS
SPARK PLUG: (GAP: .030")	CHAMPION RC12YC
VALVE CLEARANCE:	NOT ADJUSTABLE
GROUND SPEED (MPH):	FORWARD: 0 - 5.6 REVERSE: 0 - 2.5
TIRE PRESSURE:	FRONT: 14 PSI REAR: 10 PSI
CHARGING SYSTEM:	15 AMPS @ 3600 RPM
BATTERY:	AMP/HR: 35 MIN. CCA: 280 CASE SIZE: U1R
BLADE BOLT TORQUE:	30-35 FT. LBS.

WARNING: This tractor is equipped with an internal combustion engine and should not be used on or near any unimproved forest-covered, brush-covered or grass-covered land unless the engine's exhaust system is equipped with a spark arrester meeting applicable local or state laws (if any). If a spark arrester is used, it should be maintained in effective working order by the operator.

In the state of California the above is required by law (Section 4442 of the California Public Resources Code). Other states may have similar laws. Federal laws apply on federal lands. A spark arrester for the muffler is available through your nearest Sears Authorized Service Center/Department (See REPAIR PARTS section of this manual).

LIMITED TWO YEAR WARRANTY ON CRAFTSMAN RIDING EQUIPMENT

For two (2) years from the date of purchase, if this Craftsman Riding Equipment is maintained, lubricated and tuned up according to the instructions in the owner's manual, Sears will repair or replace, free of charge, any parts found to be defective in material or workmanship.

This Warranty does not cover:

- Expendable items which become worn during normal use, such as blades, spark plugs, air cleaners, belts, etc.
- Tire replacement or repair caused by punctures from outside objects, such as nails, thorns, stumps, or glass.
- Repairs necessary because of operator abuse, negligence, improper storage or accident or the failure to maintain the equipment according to the instructions contained in the owner's manual.
- Riding equipment used for commercial or rental purposes.

LIMITED 90 DAY WARRANTY ON BATTERY

For ninety (90) days from date of purchase, if any battery included with this riding equipment proves defective in material or workmanship and our testing determines the battery will not hold a charge, Sears will replace the battery at no charge.

IN-HOME WARRANTY SERVICE ON YOUR CRAFTSMAN RIDING EQUIPMENT IS AVAILABLE AT NO-CHARGE FOR 30 DAYS FROM THE DATE OF PURCHASE. PLEASE CONTACT YOUR NEAREST SERVICE CENTER. AFTER 30 DAYS FROM THE DATE OF PURCHASE, WARRANTY SERVICE IS AVAILABLE BY TAKING YOUR CRAFTSMAN RIDING EQUIPMENT TO YOUR NEAREST SEARS SERVICE CENTER. (IN-HOME WARRANTY SERVICE WILL STILL BE AVAILABLE AFTER 30 DAYS FROM THE DATE OF PURCHASE BUT A STANDARD TRIP CHARGE WILL APPLY.) THIS WARRANTY APPLIES ONLY WHILE THIS PRODUCT IS IN THE UNITED STATES.







This Warranty gives you specific legal rights, and you may also have other rights which may vary from state to state.

SEARS, ROEBUCK AND CO., D/817 WA, HOFFMAN ESTATES, IL 60179

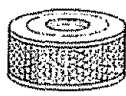
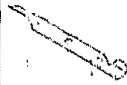

ACCESSORIES AND ATTACHMENTS

These accessories and attachments were available through most Sears retail outlets and service centers when the tractor was purchased. Most Sears stores can order these items for you when you provide the model number of your tractor.

ENGINE					MAINTENANCE	
SPARK PLUG	GAS CAN	ENGINE OIL	FUEL STABILIZER	AIR FILTER	BLADES	BELTS
						

PERFORMANCE

Sears offers a wide variety of attachments that fit your tractor. Many of these are listed below with brief explanations of how they can help you. This list was current at the time of publication; however, it may change in future years - more attachments may be added, changes may be made in these attachments, or some may no longer be available or fit your model. Contact your nearest Sears store for the accessories and attachments that are available for your tractor.

Most of these attachments do not require additional hitches or conversion kits (those that do are indicated) and are designed for easy attaching and detaching.

AERATOR promotes deep root growth for a healthy lawn. Tapered 2.5-inch steel spikes mounted on 10-inch diameter discs puncture holes in soil at close intervals to let moisture soak in. Steel weight tray for increased penetration.

BUMPER protects front end of tractor from damage.

CARTS make hauling easy. Variety of sizes available, plus accessories such as side panel kits, tool caddy, cart cover, protective mat and dolly.

CORING AERATOR takes small plugs out of soil to allow moisture and nutrients to reach grass roots. 36-inch swath. 24 hardened steel coring tips. 150 lb. capacity weight tray.

DISC HARROW has 2 gangs of 4 steel blades that angle from 10 to 20 degrees, 40 inches wide. Can hook 2 units in tandem. (Requires sleeve hitch.)

DOZER BLADE removes snow, grades dirt, sand and gravel. 48 inches wide, 17 inches high, clears 44-inch path when angled. Master lift control lever for operator ease. Spring trip for snow removal on uneven pavement; built-in float for blade to follow ground contour. Reversible, replaceable scraper bar. (Use with tire chains and wheel weights and/or rear drawbar weight.)

EASY OIL DRAIN VALVE makes oil changes easier, faster.

FRONT NOSE ROLLER canters in front of mower deck to reduce chances of "scalping" on uneven terrain.

GANG HITCH lets you tow 2 or 3 pull-behind attachments at once, such as sweepers, dethatchers, aerators (not for use with rollers, carts or other heavy attachments).

MULCH RAKE/DETHATCHER loosens soil and flips thatch and matted leaves to lawn surface for easy pickup. Twenty spring tine teeth. Useful to prepare bare areas for seeding. Available for front or rear mounting.

HIGH PERFORMANCE REEL-ACTION SPRING TINE DETHATCHER covers 36-inch wide path and tosses thatch into large hopper. Mounts behind tractor.

PLOW turns soil 6 inches deep, cuts 10-inch furrow. Crank adjustment controls depth, 3-position yoke sets width. Heavy steel landside for straight furrowing. (Requires sleeve hitch.)

RAMP TOPS AND FEET let you load and unload tractor from a pickup truck. Use with 2 x 8 or 2 x 10 lumber.

REAR GRADER BLADE is 42 inches wide and operated from driver's seat. Reversible steel blade can be angled at 30 degrees for grading. Reverses for pushing snow backwards. (Requires sleeve hitch.)

ROLLER for smoother lawn surface. 36-inch wide, 18-inch diameter water-tight drum holds up to 390 lbs. of weight. Rounded edges prevent harm to turf. Adjustable scraper automatically cleans drum.

SLEEVE CULTIVATOR is 43 inches wide. Prepares ground for seeding, helps weed control. Steel frame holds 5 adjustable sweeps. Adjusts vertically, horizontally. (Requires sleeve hitch.) **Optional accessory:** steel furrow opener for wider openings for potatoes, corn, and other deep-seeded crops.

SLEEVE HITCH for use with master lift system. Single pin couples/uncouples.

SNOWTHROWER has 42-inch swath. Drum-type auger handles powdery and wet/heavy snow. Mounts easily with simple pin arrangement. Discharge chute adjusts from tractor seat. 6-inch diameter spout discharges snow 10 to 50 feet. Lift controlled at tractor seat. (Use with chains and wheel weights and/or rear drawbar weight.)

SPRAYERS use 12-volt DC electric motor that connects to the tractor battery or other 12-volt source. Includes booms for automatic spraying and hand held wand for spot spraying. Wand has adjustable spray pattern. For applying herbicides, insecticides, fungicides and liquid fertilizers.

SPREADER/SEEDERS make seeding, fertilizing, and weed killing easy. Broadcast spreaders are also useful for granular de-icers and sand.

SWEEPERS let you collect grass clippings and leaves.

TILLER has 8 hp engine to prepare seed beds, cultivate, and compost garden residue. Chain-drive transmission. Six 1.1-inch diameter one piece heat-treated steel lines. Tills 30-inch path. (Requires sleeve hitch.) Or use 5 hp tow-behind **TILLER** with 36-inch swath to prepare seed beds, cultivate and compost garden residue. Tiller has its own built-in lift and depth control system and does NOT require a sleeve hitch. Fits any lawn, yard or garden tractor. Simply hook up to the tractor drawbar and go! **Optional accessories** for 5 hp tiller convert unit for dethatching, aerating, hilling, without tools.

TIRE CHAINS are heavy duty; closely spaced extra-large cross links give smooth ride, outstanding traction.

TRACTOR CAB has heavy duty vinyl fabric over tubular steel frame. ABS plastic top; clear plastic windshield offers 360 degree visibility. Hinged metal doors with catch. Keeps operator warm and dry. Remove vinyl sides and windshields for use as sun protector in summer. **Optional accessories** include: tinted/tempered solid safety glass windshield with hand operated wiper; 12-volt amber caution light for mounting on cab top.

VACS for powerful collection of heavy grass clippings and leaves. **Optional wand attachment** to pick up debris in hard-to-reach places. **VAC/CHIPPER** includes a chipper-shredder.

WEIGHT BRACKET for drawbar for snow removal applications. Can be mounted on front of tractor for plowing applications. Uses (1) 55 lb weight.

WHEEL WEIGHTS for rear wheels provide needed traction for snow removal or dozing heavy materials.

CONTENTS OF HARDWARE PACK

Parts Bag contents shown full size

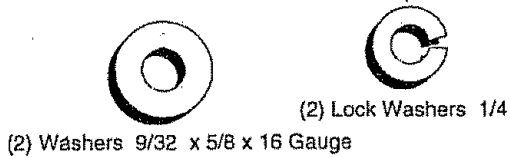
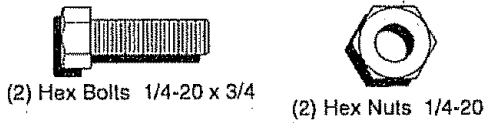
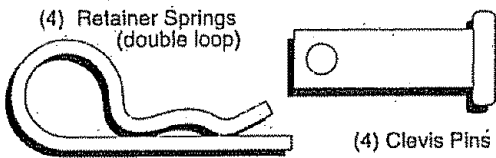
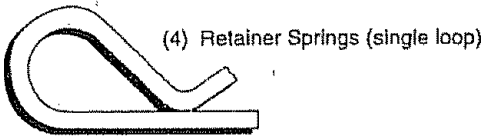
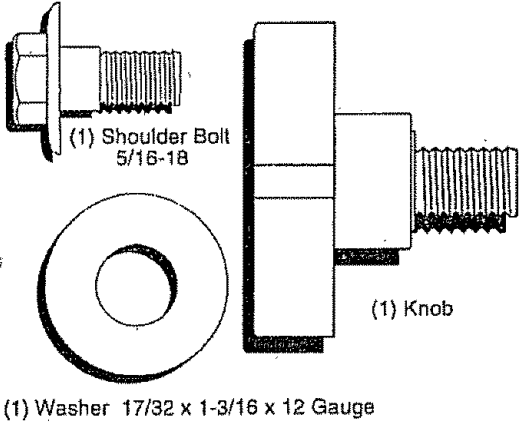

Parts packed separately in carton

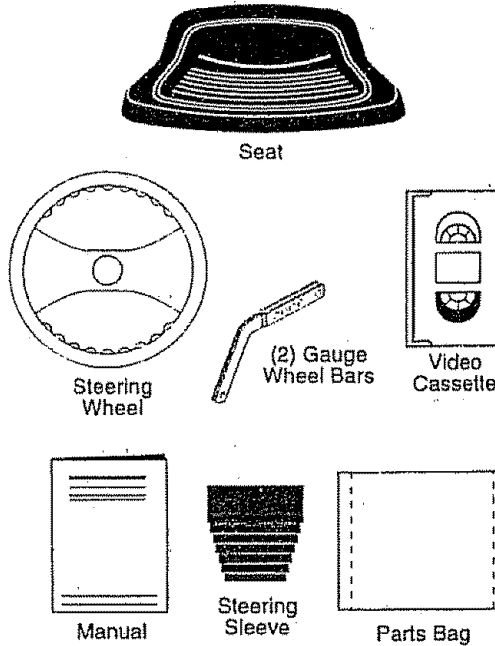

Parts bag contents not shown full size

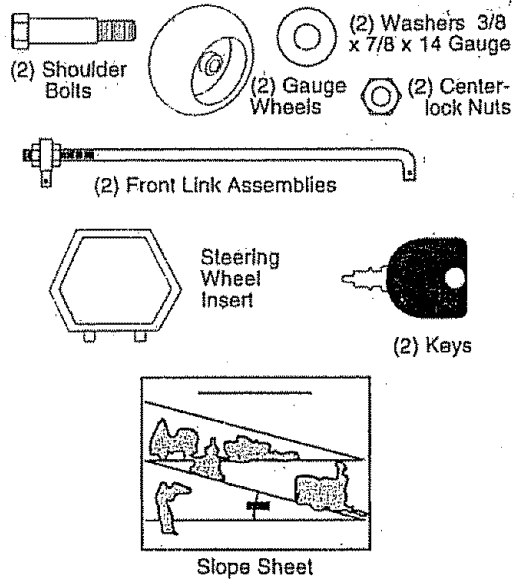

ASSEMBLY

Your new tractor has been assembled at the factory with the exception of those parts left unassembled for shipping purposes. To ensure safe and proper operation of your tractor all parts and hardware you assemble must be tightened securely. Use the correct tools as necessary to insure proper tightness.

TOOLS REQUIRED FOR ASSEMBLY

A socket wrench set will make assembly easier. Standard wrench sizes are listed.

- | | |
|------------------------------------|---------------------|
| (2) 7/16" wrenches | Tire pressure gauge |
| (1) 1/2" wrench | Utility knife |
| (1) 9/16" wrench | |
| (1) 3/4" socket with drive ratchet | |

When right or left hand is mentioned in this manual, it means when you are in the operating position (seated behind the steering wheel).

TO REMOVE TRACTOR FROM CARTON

UNPACK CARTON

- Remove all accessible loose parts and parts cartons from carton (See page 6).
- Cut, from top to bottom, along lines on all four corners of carton, and lay panels flat.
- Remove mower and packing materials.
- Check for any additional loose parts or cartons and remove.

BEFORE ROLLING TRACTOR OFF SKID

ATTACH STEERING WHEEL (See Fig. 1)

- Remove hex bolt, lock washer and large flat washer from steering shaft.
- Position front wheels of the tractor so they are pointing straight forward.
- Slide steering sleeve over steering shaft.
- Position steering wheel so cross bars are horizontal (left to right) and slide onto steering wheel adapter.
- Secure steering wheel to steering shaft with hex bolt, lock washer and large flat washer previously removed. Tighten securely.
- Snap steering wheel insert into center of steering wheel.
- Remove protective plastic from tractor hood and grill.

IMPORTANT: CHECK FOR AND REMOVE ANY STAPLES IN SKID THAT MAY PUNCTURE TIRES WHERE TRACTOR IS TO ROLL OFF SKID

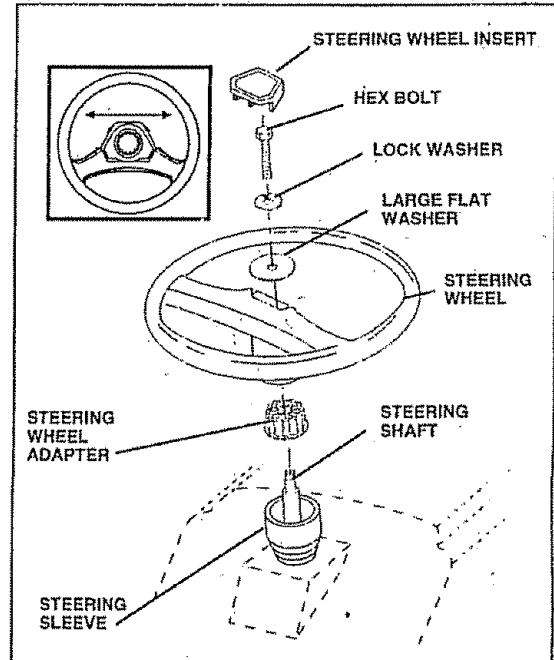

FIG. 1

TO ROLL TRACTOR OFF SKID (See Operation section for location and function of controls)

- Press lift lever plunger and raise attachment lift lever to its highest position.
- Release parking brake by depressing clutch/brake pedal.
- Place freewheel control in freewheeling position to disengage transmission (See "TO TRANSPORT" in the Operation section of this manual).
- Roll tractor forward off skid.
- Remove mower and packing materials.
- Remove ties from V-belts.

ASSEMBLY

CONNECT BATTERY (See Fig. 2)



CAUTION: Do not short battery terminals. Before connecting battery, remove metal bracelets, wristwatch bands, rings, etc.

Positive terminal must be connected first to prevent sparking from accidental grounding.

- Lift hood to raised position
- Open terminal access doors, remove terminal protective caps and discard.
- If this battery is put into service after month and year indicated on label (label located between terminals) charge battery for minimum of one hour at 6-10 amps.
- First connect RED battery cable to positive (+) battery terminal with hex bolt, flat washer, lock washer and hex nut as shown. Tighten securely.
- Connect BLACK grounding cable to negative (-) battery terminal with remaining hex bolt, flat washer, lock washer and hex nut. Tighten securely.
- Close terminal access doors.

Use terminal access doors for:

- Inspection for secure connections (to tighten hardware).
- Inspection for corrosion
- Testing battery
- Jumping (if required).
- Periodic charging

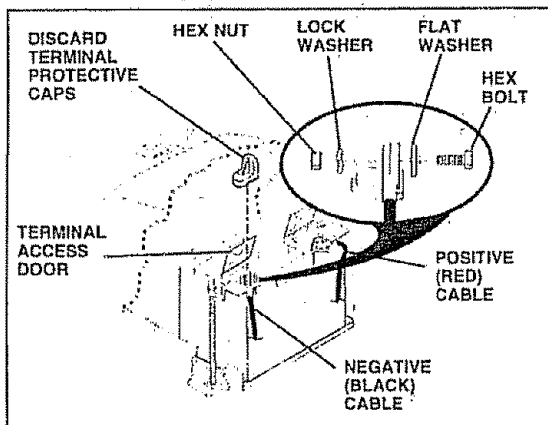

FIG. 2

INSTALL SEAT (See Fig. 3)

Adjust seat before tightening adjustment knob.

- Remove cardboard packing on seat pan.
- Place seat on seat pan and assemble shoulder bolt.
- Assemble adjustment knob and flat washer loosely. Do not tighten.
- Tighten shoulder bolt securely.
- Lower seat into operating position and sit on seat
- Slide seat until a comfortable position is reached which allows you to press clutch/brake pedal all the way down.
- Get off seat without moving its adjusted position.
- Raise seat and tighten adjustment knob securely.

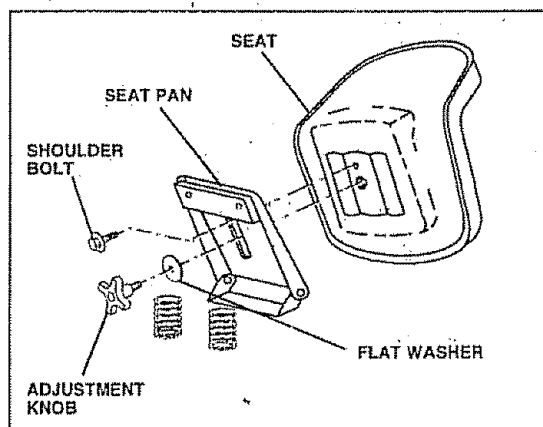

FIG. 3

CHECK TIRE PRESSURE

The tires on your tractor were overinflated at the factory for shipping purposes. Correct tire pressure is important for best cutting performance.

- Reduce tire pressure to PSI shown in "PRODUCT SPECIFICATIONS" on page 3 of this manual

CHECK BRAKE SYSTEM

After you learn how to operate your tractor, check to see that the brake is properly adjusted. See "TO ADJUST BRAKE" in the Service and Adjustments section of this manual.

ASSEMBLY

INSTALL MOWER AND DRIVE BELT (See Figs. 4 and 7)

Be sure tractor is on level surface and mower suspension arms are raised with attachment lift control. Engage parking brake.

- Cut and remove ties securing anti-sway bar and belts. Swing anti-sway bar to left side of mower deck.
- Slide mower under tractor with discharge guard to right side of tractor.

IMPORTANT: CHECK BELT FOR PROPER ROUTING IN ALL MOWER PULLEY GROOVES. INSTALL BELT INTO ELECTRIC CLUTCH PULLEY GROOVE

- Install one front link in top hole of the L.H. front mower bracket and L.H. front suspension bracket. Retain with two single loop retainer springs as shown.
- Install second front link in R.H. front suspension bracket only and retain with single loop retainer spring as shown.
- Slide right side of mower back and install link in top hole of R.H. front mower bracket. Retain with single loop retainer spring as shown.
- Turn height adjustment knob counterclockwise until it stops.
- Lower mower linkage with attachment lift control.
- Place the suspension arms on inward pointing deck pins. If necessary, rock and raise front of mower to align deck pins with the holes in suspension arms.

Retain with double loop retainer springs with loops down as shown.

- Connect anti-sway bar to chassis bracket under left footrest and retain with double loop retainer spring.
- Turn height adjustment knob clockwise to remove slack from mower suspension.
- Raise deck to highest position.
- Assemble gauge wheel bars to brackets using clevis pins and double loop retainer springs.
- Assemble gauge wheels as shown using long shoulder bolts, 3/8 washers, and 3/8-16 center locknuts. Tighten securely.
- Adjust gauge wheels before operating mower as shown in the Operation section of this manual.

CHECK MOWER LEVELNESS

For best cutting results, mower should be properly leveled. See "TO LEVEL MOWER HOUSING" in the Service and Adjustments section of this manual.

CHECK FOR PROPER POSITION OF ALL BELTS

See the figures that are shown for replacing motion, mower drive, and mower blade drive belts in the Service and Adjustments section of this manual. Verify that the belts are routed correctly.

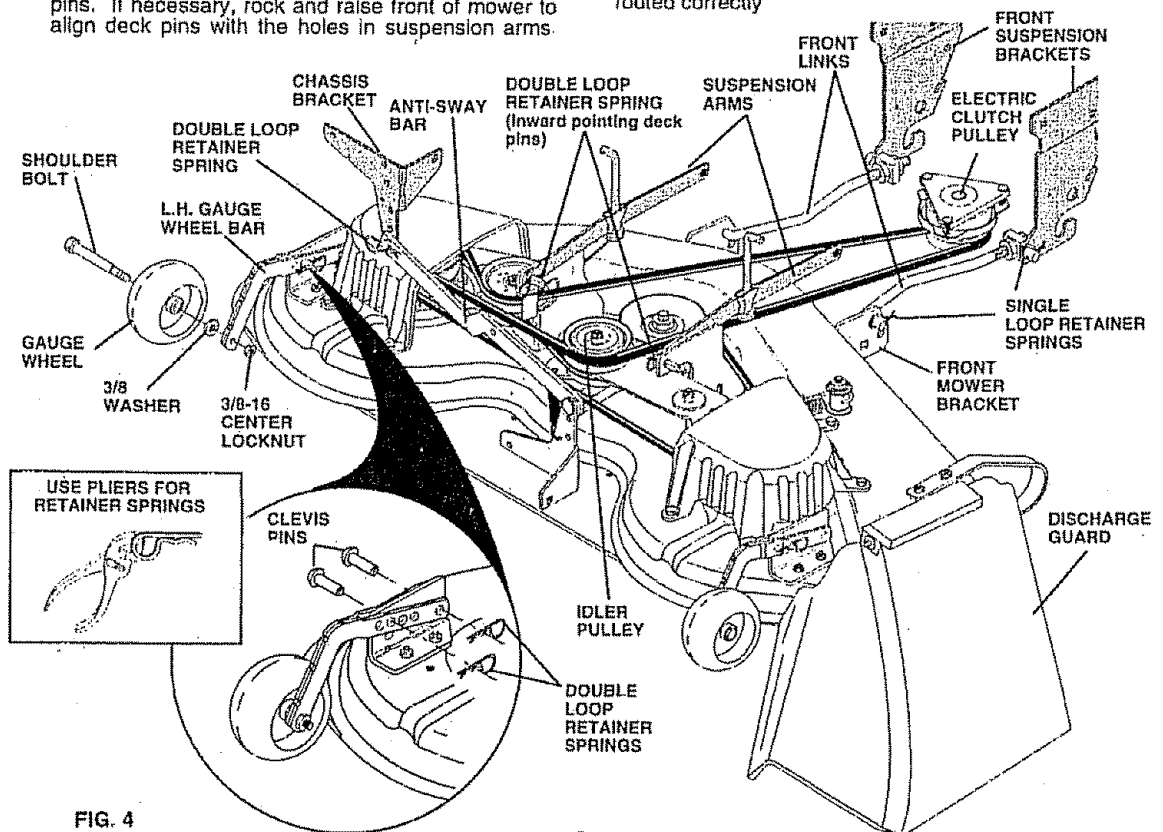

FIG. 4



ASSEMBLY

✓ CHECKLIST

BEFORE YOU OPERATE AND ENJOY YOUR NEW TRACTOR, WE WISH TO ASSURE THAT YOU RECEIVE THE BEST PERFORMANCE AND SATISFACTION FROM THIS QUALITY PRODUCT.

PLEASE REVIEW THE FOLLOWING CHECKLIST:

- ✓ All assembly instructions have been completed.
- ✓ No remaining loose parts in carton.
- ✓ Battery is properly prepared and charged. (Minimum 1 hour at 6 amps).
- ✓ Seat is adjusted comfortably and tightened securely.
- ✓ All tires are properly inflated. (For shipping purposes, the tires were overinflated at the factory).
- ✓ Be sure mower deck is properly leveled side-to-side/ front-to-rear for best cutting results. (Tires must be properly inflated for leveling).
- ✓ Check mower and drive belts. Be sure they are routed properly around pulleys and inside all belt keepers.
- ✓ Check wiring. See that all connections are still secure and wires are properly clamped.
- ✓ Before driving tractor, be sure freewheel control is in drive position.

WHILE LEARNING HOW TO USE YOUR TRACTOR, PAY EXTRA ATTENTION TO THE FOLLOWING IMPORTANT ITEMS:

- ✓ Engine oil is at proper level.
- ✓ Fuel tank is filled with fresh, clean, regular unleaded gasoline.
- ✓ Become familiar with all controls - their location and function. Operate them before you start the engine.
- ✓ Be sure brake system is in safe operating condition.
- ✓ It is important to purge the transmission before operating your tractor for the first time. Follow proper starting and transmission purging instructions (See "TO START ENGINE" and "PURGE TRANSMISSION" in the Operation section of this manual).

OPERATION

These symbols may appear on your tractor or in literature supplied with the product. Learn and understand their meaning.

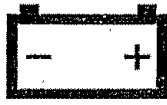

BATTERY



CAUTION OR WARNING



REVERSE



FORWARD



FAST



SLOW



ENGINE ON



ENGINE OFF



OIL PRESSURE



CLUTCH



LIGHTS ON



LIGHTS OFF



FUEL



CHOKE

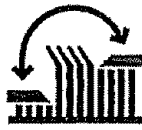

MOWER HEIGHT

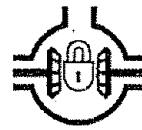

DIFFERENTIAL LOCK



PARKING BRAKE LOCKED



UNLOCKED



MOWER LIFT



REVERSE



NEUTRAL



HIGH



LOW



PARKING BRAKE



ATTACHMENT CLUTCH ENGAGED



ATTACHMENT CLUTCH DISENGAGED



IGNITION

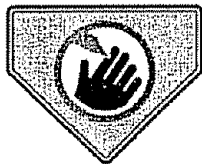

DANGER, KEEP HANDS AND FEET AWAY

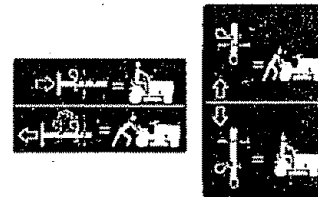

HYDROSTATIC FREE WHEEL
(Hydro Models only)

OPERATION

KNOW YOUR TRACTOR

READ THIS OWNER'S MANUAL AND SAFETY RULES BEFORE OPERATING YOUR TRACTOR.

Compare the illustrations with your tractor to familiarize yourself with the location of various controls and adjustments. Save this manual for future reference.

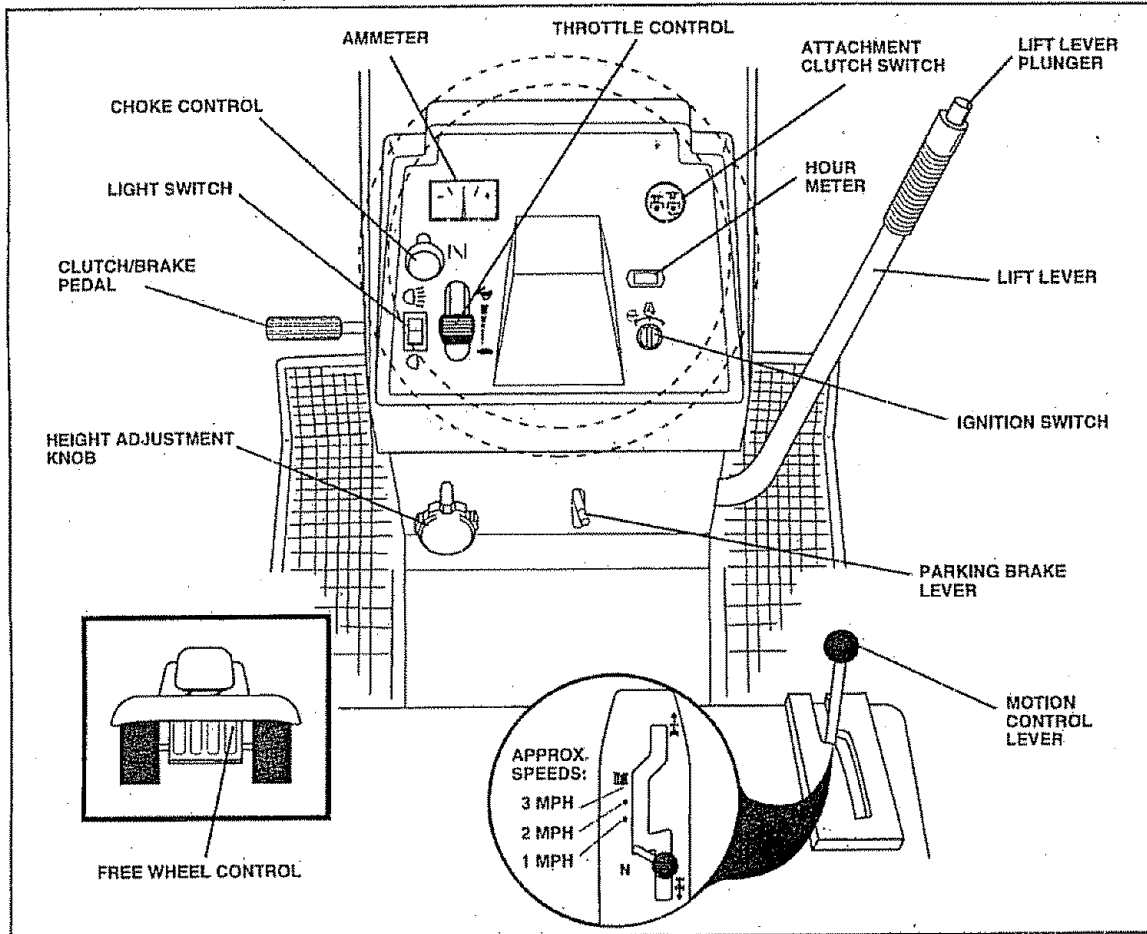

FIG. 5

Our tractors conform to the safety standards of the American National Standards Institute.

ATTACHMENT CLUTCH SWITCH - Used to engage mower blades or other attachments mounted to your tractor.

LIFT LEVER - Used to raise and lower mower deck or other attachments mounted to your tractor.

CLUTCH/BRAKE PEDAL - Used for declutching and braking the tractor and starting the engine.

MOTION CONTROL - Selects the speed and direction of tractor.

CHOKE CONTROL - Used when starting a cold engine.

LIGHT SWITCH - Turns the headlights on and off.

THROTTLE CONTROL - Used to control engine speed.

FREEWHEEL CONTROL - Disengages transmission for pushing or slowly towing the tractor with the engine off.

IGNITION SWITCH - Used to start and stop the engine.

AMMETER - Indicates battery charging (+) or discharging (-).

PARKING BRAKE LEVER - Locks clutch/brake pedal into the brake position.

HEIGHT ADJUSTMENT KNOB - Used to adjust the mower height.

HOURMETER - Indicates hours of operation.

OPERATION



The operation of any tractor can result in foreign objects thrown into the eyes, which can result in severe eye damage. Always wear safety glasses or eye shields while operating your tractor or performing any adjustments or repairs. We recommend a wide vision safety mask over the spectacles or standard safety glasses.

HOW TO USE YOUR TRACTOR

TO SET PARKING BRAKE (See Fig. 6)

Your tractor is equipped with an operator presence sensing switch. When engine is running, any attempt by the operator to leave the seat without first setting the parking brake will shut off the engine.

- Depress clutch/brake pedal into full "BRAKE" position and hold
- Place parking brake lever in "ENGAGED" position and release pressure from clutch/brake pedal. Pedal should remain in "BRAKE" position. Make sure parking brake will hold tractor secure.

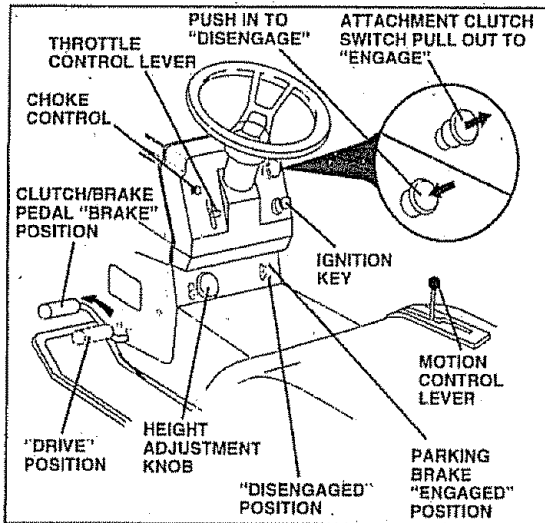

FIG. 6

STOPPING (See Fig. 6)

MOWER BLADES -

- Move attachment clutch switch to "DISENGAGED" position.

GROUND DRIVE -

- Depress clutch/brake pedal into full "BRAKE" position.
- Move motion control lever to neutral (N) position.

IMPORTANT: THE MOTION CONTROL LEVER DOES NOT RETURN TO NEUTRAL (N) POSITION WHEN THE CLUTCH/BRAKE PEDAL IS DEPRESSED.

ENGINE -

- Move throttle control to slow (S) position.

NOTE: Failure to move throttle control to slow (S) position and allowing engine to idle before stopping may cause engine to "backfire".

- Turn ignition key to "OFF" position and remove key. Always remove key when leaving tractor to prevent unauthorized use.
- Never use choke to stop engine.

NOTE: Under certain conditions when unit is standing idle with the engine running, hot engine exhaust gases may cause "browning" of grass. To eliminate this possibility, always stop engine when stopping tractor on grass areas.



CAUTION: Always stop tractor completely, as described above, before leaving the operator's position; to empty grass catcher, etc.

TO USE CHOKE CONTROL (See Fig. 6)

Use choke control whenever you are starting a cold engine. Do not use to start a warm engine.

- To engage choke control, pull knob out. Slowly push knob in to disengage.

TO USE THROTTLE CONTROL (See Fig. 6)

Always operate engine at full throttle.

- Operating engine at less than full throttle reduces the battery charging rate
- Full throttle offers the best bagging and mower performance.

TO MOVE FORWARD AND BACKWARD (See Fig. 6)

The direction and speed of movement is controlled by the motion control lever.

- Start tractor with motion control lever in neutral (N) position
- Release parking brake and clutch/brake pedal.
- Slowly move motion control lever to desired position.

TO ADJUST MOWER CUTTING HEIGHT (See Fig. 6)

The cutting height is controlled by turning the height adjustment knob in desired direction.

- Turn knob clockwise (↻) to raise cutting height.
- Turn knob counterclockwise (↺) to lower cutting height.

The cutting height range is approximately 1-1/4" to 4-1/2". The heights are measured from the ground to the blade tip with the engine not running. These heights are approximate and may vary depending upon soil conditions, height of grass and types of grass being mowed.

- The average lawn should be cut to approximately 2-1/2 inches during the cool season and to over 3 inches during hot months. For healthier and better looking lawns, mow often and after moderate growth.
- For best cutting performance, grass over 6 inches in height should be mowed twice. Make the first cut relatively high; the second to desired height.



OPERATION

TO ADJUST GAUGE WHEELS (See Fig. 7)

Adjust gauge wheels with tractor on a flat level surface

- Adjust mower to desired cutting height.
- Lower mower with lift control. Remove rear retainer spring and clevis pin which secure each gauge wheel.
- Lower gauge wheels to ground. Raise gauge wheels slightly to align holes in bracket and gauge wheel bar and insert clevis pins. Gauge wheels should be slightly off the ground.
- Replace retainer springs into clevis pins

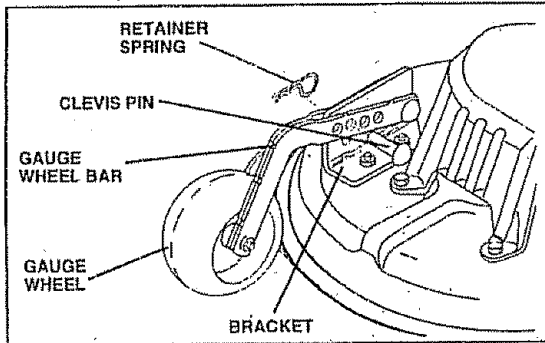

FIG. 7

TO OPERATE MOWER (See Figs. 5 and 6)

Your tractor is equipped with an operator presence sensing switch. Any attempt by the operator to leave the seat with the engine running and the attachment clutch engaged will shut off the engine.

- Select desired height of cut.
- Lower mower with attachment lift control.
- Start mower blades by engaging attachment clutch control.
- TO STOP MOWER BLADES - disengage attachment clutch control.



CAUTION: Do not operate the mower without either the entire grass catcher, on mowers so equipped, or the discharge guard in place.

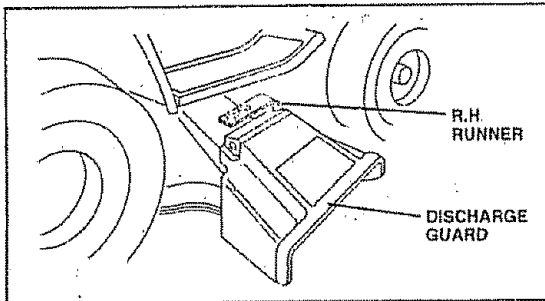

FIG. 8

TO OPERATE ON HILLS



CAUTION: Do not drive up or down hills with slopes greater than 15° and do not drive across any slope.

- Choose the slowest speed before starting up or down hills.
- Avoid stopping or changing speed on hills.
- If slowing is necessary, move throttle control lever to slower position.
- If stopping is absolutely necessary, push clutch/brake pedal quickly to brake position and engage parking brake.
- Move motion control lever to neutral (N) position.

IMPORTANT: THE MOTION CONTROL LEVER DOES NOT RETURN TO NEUTRAL (N) POSITION WHEN THE CLUTCH/BRAKE PEDAL IS DEPRESSED

- To restart movement, slowly release parking brake and clutch/brake pedal.
- Slowly move motion control lever to slowest setting.
- Make all turns slowly.

TO TRANSPORT (See Figs. 5 and 9)

When pushing or towing your tractor, be sure to disengage transmission by placing freewheel control in freewheeling position. Free wheel control is located at the rear drawbar of tractor.

- Raise attachment lift to highest position with attachment lift control.
- Remove retainer spring from freewheel control rod.
- Push control rod in to disengage transmission and reinsert retainer spring into control rod hole now on back side of the bracket.
- Do not push or tow tractor at more than two (2) MPH.
- To reengage transmission, reverse above procedure.

NOTE: To protect hood from damage when transporting your tractor on a truck or a trailer, be sure hood is closed and secured to tractor. Use an appropriate means of tying hood to tractor (rope, cord, etc.).

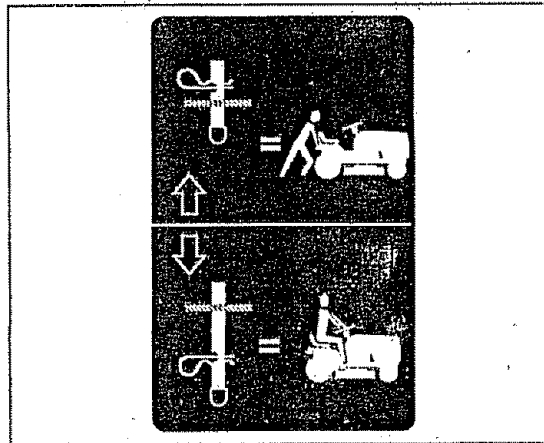

FIG. 9

OPERATION

BEFORE STARTING THE ENGINE

CHECK ENGINE OIL LEVEL (See Fig. 10)

- The engine in your tractor has been shipped, from the factory, already filled with summer weight oil.
- Check engine oil with tractor on level ground.
- Unthread and remove oil fill cap/dipstick; wipe oil off. Reinsert the dipstick into the tube and rest oil fill cap on the tube. Do not thread the cap onto the tube. Remove and read oil level. If necessary, add oil until "FULL" mark on dipstick is reached. Do not overfill.
- For cold weather operation you should change oil for easier starting (See "OIL VISCOSITY CHART" in the Customer Responsibilities section of this manual).
- To change engine oil, see the Customer Responsibilities section in this manual.

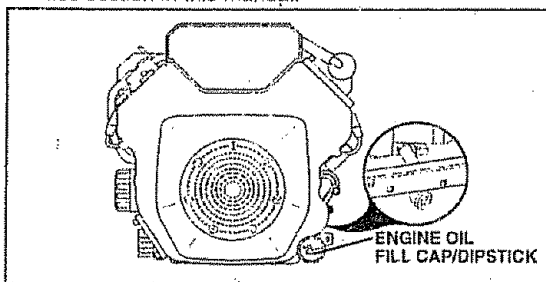

FIG. 10

ADD GASOLINE

- Fill fuel tank. Use fresh, clean, regular unleaded gasoline with a minimum of 87 octane. (Use of leaded gasoline will increase carbon and lead oxide deposits and reduce valve life). Do not mix oil with gasoline. Purchase fuel in quantities that can be used within 30 days to assure fuel freshness.

IMPORTANT: WHEN OPERATING IN TEMPERATURES BELOW 32°F (0°C), USE FRESH, CLEAN WINTER GRADE GASOLINE TO HELP INSURE GOOD COLD WEATHER STARTING.

WARNING: Experience indicates that alcohol blended fuels (called gasohol or using ethanol or methanol) can attract moisture which leads to separation and formation of acids during storage. Acidic gas can damage the fuel system of an engine while in storage. To avoid engine problems, the fuel system should be emptied before storage of 30 days or longer. Drain the gas tank, start the engine and let it run until the fuel lines and carburetor are empty. Use fresh fuel next season. See Storage Instructions for additional information. Never use engine or carburetor cleaner products in the fuel tank or permanent damage may occur.

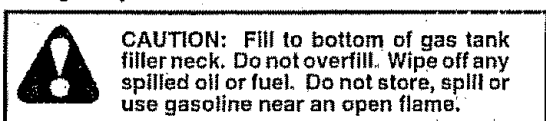

TO START ENGINE (See Fig. 6)

When starting the engine for the first time or if the engine has run out of fuel, it will take extra cranking time to move fuel from the tank to the engine.

- Depress clutch/brake pedal and set parking brake.
- Place motion control lever in neutral (N) position
- Move attachment clutch to "DISENGAGED" position.
- Move throttle control to fast (F) position
- Pull choke control out for a cold engine start attempt. For a warm engine start attempt the choke control may not be needed.

Note: Before starting, read the warm and cold starting procedures below.

- Insert key into ignition and turn key clockwise to "START" position and release key as soon as engine starts. Do not run starter continuously for more than fifteen seconds per minute. If the engine does not start after several attempts, push choke control in, wait a few minutes and try again. If engine still does not start, pull the choke control out and retry.

WARM WEATHER STARTING (50° F and above)

- When engine starts, slowly push choke control in until the engine begins to run smoothly. If the engine starts to run roughly, pull the choke control out slightly for a few seconds and then continue to push the control in slowly.
- The attachments and ground drive can now be used. If the engine does not accept the load, restart the engine and allow it to warm up for one minute using the choke as described above.

COLD WEATHER STARTING (50° F and below)

- When engine starts, slowly push choke control in until the engine begins to run smoothly. Continue to push the choke control in small steps allowing the engine to accept small changes in speed and load, until the choke control is fully in. If the engine starts to run roughly, pull the choke control out slightly for a few seconds and then continue to push the control in slowly. This may require an engine warm-up period from several seconds to several minutes, depending on the temperature.

HYDROSTATIC TRANSMISSION WARM UP

- Before driving the unit in cold weather, the transmission should be warmed up as follows:
 - Be sure the tractor is on level ground.
 - Place the motion control lever in neutral. Release the parking brake and let the clutch/brake slowly return to operating position.
 - Allow one minute for transmission to warm up. This can be done during the engine warm up period.
- The attachments can be used during the engine warm-up period after the transmission has been warmed up and may require the choke control be pulled out slightly.

NOTE: If at a high altitude (above 3000 feet) or in cold temperatures (below 32 F) the carburetor fuel mixture may need to be adjusted for best engine performance. See "TO ADJUST CARBURETOR" in the Service and Adjustments section of this manual.

OPERATION

PURGE TRANSMISSION



CAUTION: Never engage or disengage freewheel lever while the engine is running.

To ensure proper operation and performance, it is recommended that the transmission be purged before operating tractor for the first time. This procedure will remove any trapped air inside the transmission which may have developed during shipping of your tractor.

IMPORTANT: SHOULD YOUR TRANSMISSION REQUIRE REMOVAL FOR SERVICE OR REPLACEMENT, IT SHOULD BE PURGED AFTER REINSTALLATION BEFORE OPERATING THE TRACTOR.

- Place tractor safely on level surface with engine off and parking brake set.
- Disengage transmission by placing freewheel control in freewheeling position (See "TO TRANSPORT" in this section of manual).
- Sitting in the tractor seat, start engine. After the engine is running, move throttle control to slow (S) position. With motion control lever in neutral (N) position, slowly disengage clutch/brake pedal.
- Move motion control lever to full forward position and hold for five (5) seconds. Move lever to full reverse position and hold for five (5) seconds. Repeat this procedure three (3) times.

NOTE: During this procedure there will be no movement of drive wheels. The air is being removed from hydraulic drive system.

- Move motion control lever to neutral (N) position. Shut-off engine and set parking brake.
- Engage transmission by placing freewheel control in driving position (See "TO TRANSPORT" in this section of manual).
- Sitting in the tractor seat, start engine. After the engine is running, move throttle control to half (1/2) speed. With motion control lever in neutral (N) position, slowly disengage clutch/brake pedal.
- Slowly move motion control lever forward, after the tractor moves approximately five (5) feet, slowly move motion control lever to reverse position. After the tractor moves approximately five (5) feet return the motion control lever to the neutral (N) position. Repeat this procedure with the motion control lever three (3) times.
- Your tractor is now purged and now ready for normal operation.

MOWING TIPS

- Tire chains cannot be used when the mower housing is attached to tractor.
- Mower should be properly leveled for best mowing performance. See "TO LEVEL MOWER HOUSING" in the Service and Adjustments section of this manual.
- Use the runner on the right hand side of mower as a guide. The blade cuts approximately an inch outside the runner (See Fig. 8)
- The left hand side of mower should be used for trimming.
- Drive so that clippings are discharged onto the area that has been cut. Have the cut area to the right of the tractor. This will result in a more even distribution of clippings and more uniform cutting.
- When mowing large areas, start by turning to the right so that clippings will discharge away from shrubs, fences, driveways, etc. After one or two rounds, mow in the opposite direction making left hand turns until finished (See Fig. 11)

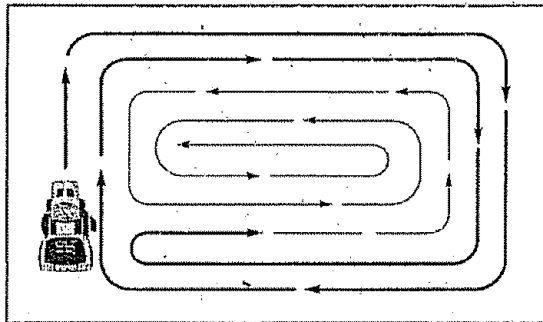

FIG. 11

- If grass is extremely tall, it should be mowed twice to reduce load and possible fire hazard from dried clippings. Make first cut relatively high; the second to the desired height.
- Do not mow grass when it is wet. Wet grass will plug mower and leave undesirable clumps. Allow grass to dry before mowing.
- Always operate engine at full throttle when mowing to assure better mowing performance and proper discharge of material. Regulate ground speed by selecting a low enough gear to give the mower cutting performance as well as the quality of cut desired.
- When operating attachments, select a ground speed that will suit the terrain and give best performance of the attachment being used.

CUSTOMER RESPONSIBILITIES

MAINTENANCE SCHEDULE FILL IN DATES AS YOU COMPLETE REGULAR SERVICE		BEFORE EACH USE							SERVICE DATES									
		BEFORE EACH USE	FIRST 2 HOURS	EVERY 8 HOURS	EVERY 25 HOURS	EVERY 50 HOURS	EVERY 100 HOURS	BEFORE SEASON	BEFORE STORAGE									
TRACTOR	Check Brake Operation	✓		✓														
	Check Tire Pressure	✓		✓														
	Check for Loose Fasteners	✓						✓ ₇		✓								
	Sharpen/Replace Mower Blades				✓ ₄													
	Lubrication Chart				✓					✓								
	Check Battery Level/Recharge				✓ ₆													
	Clean Battery and Terminals				✓					✓								
	Check Transaxle Cooling				✓													
	Adjust Blade Belt(s) Tension								✓ ₅									
	Adjust Mowon Drive Belt(s) Tension								✓ ₅									
ENGINE	Check Engine Oil Level	✓		✓														
	Change Engine Oil		✓		✓ _{1,2,3}					✓								
	Clean Air Filter				✓ ₂													
	Clean Air Screen				✓ ₂													
	Inspect Muffler/Spark Arrester					✓												
	Replace Oil Filter (If equipped)								✓ _{1,2}									
	Clean Engine Cooling Fins								✓ ₂									
	Replace Spark Plug								✓	✓								
	Replace Air Filter Paper Cartridge								✓ ₂									
Replace Fuel Filter										✓								

- 1 - Change more often when operating under a heavy load or in high ambient temperatures.
 2 - Service more often when operating in dirty or dusty conditions.
 3 - If equipped with oil filter, change oil every 50 hours.
 4 - Replace blades more often when mowing in sandy soil.
 5 - If equipped with adjustable system.
 6 - Not required if equipped with maintenance-free battery.
 7 - Tighten front axle pivot bolt to 35 ft.-lbs. maximum. Do not overtighten.

GENERAL RECOMMENDATIONS

The warranty on this tractor does not cover items that have been subjected to operator abuse or negligence. To receive full value from the warranty, operator must maintain tractor as instructed in this manual.

Some adjustments will need to be made periodically to properly maintain your tractor.

All adjustments in the Service and Adjustments section of this manual should be checked at least once each season.

- Once a year you should replace the spark plug, clean or replace air filter, and check blades and belts for wear. A new spark plug and clean air filter assure proper air-fuel mixture and help your engine run better and last longer.

BEFORE EACH USE

- Check engine oil level.
- Check brake operation.
- Check tire pressure.
- Check for loose fasteners.

IMPORTANT: DO NOT OIL OR GREASE THE PIVOT POINTS WHICH HAVE SPECIAL NYLON BEARINGS. VISCOUS LUBRICANTS WILL ATTRACT DUST AND DIRT THAT WILL SHORTEN THE LIFE OF THE SELF-LUBRICATING BEARINGS. IF YOU FEEL THEY MUST BE LUBRICATED, USE ONLY A DRY, POWDERED GRAPHITE TYPE LUBRICANT SPARINGLY.

LUBRICATION CHART

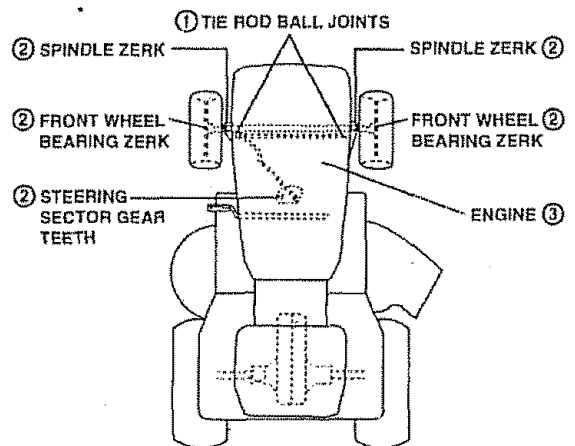

- 1 SPRAY SILICONE LUBRICANT (MOVE BOOTS TO LUBRICATE)
- 2 GENERAL PURPOSE GREASE
- 3 REFER TO CUSTOMER RESPONSIBILITIES "ENGINE" SECTION



CUSTOMER RESPONSIBILITIES

TRACTOR

Always observe safety rules when performing any maintenance.

BRAKE OPERATION

If tractor requires more than six (6) feet stopping distance at high speed in highest gear, then brake must be adjusted. (See "TO ADJUST BRAKE" in the Service and Adjustments section of this manual).

TIRES

- Maintain proper air pressure in all tires (See "PRODUCT SPECIFICATIONS" on page 3 of this manual):
- Keep tires free of gasoline, oil, or insect control chemicals which can harm rubber.
- Avoid stumps, stones, deep ruts, sharp objects and other hazards that may cause tire damage.

BLADE CARE

For best results mower blades must be kept sharp. Replace bent or damaged blades.

BLADE REMOVAL. (See Fig. 12)

- Raise mower to highest position to allow access to blades.
- Remove hex bolt, lock washer and flat washer securing blade.
- Install new or resharpened blade with trailing edge up towards deck as shown.
- Reassemble hex bolt, lock washer and flat washer in exact order as shown.
- Tighten bolt securely (30-35 Ft. Lbs. torque).

IMPORTANT: BLADE BOLT IS GRADE 8 HEAT TREATED

NOTE: We do not recommend sharpening blade - but if you do, be sure the blade is balanced.

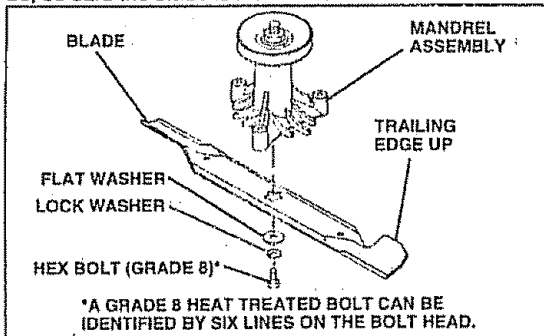

FIG. 12

TO SHARPEN BLADE (See Fig. 13)

Care should be taken to keep the blade balanced. An unbalanced blade will cause excessive vibration and eventual damage to mower and engine.

- The blade can be sharpened with a file or on a grinding wheel. Do not attempt to sharpen while on the mower.
- To check blade balance, you will need a 5/8" diameter steel bolt, pin, or a cone balancer. (When using a cone balancer, follow the instructions supplied with balancer).
- Slide blade on to an unthreaded portion of the steel bolt or pin and hold the bolt or pin parallel with the ground. If blade is balanced, it should remain in a horizontal position. If either end of the blade moves downward, sharpen the heavy end until the blade is balanced.

NOTE: Do not use a nail for balancing blade. The lobes of the center hole may appear to be centered, but are not.

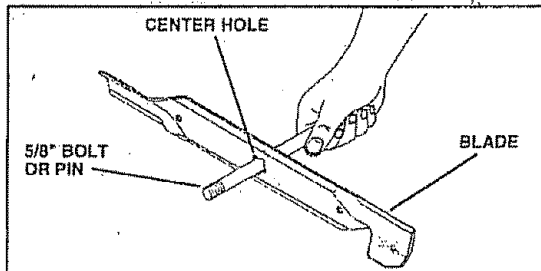

FIG. 13

BATTERY

Your tractor has a battery charging system which is sufficient for normal use. However, periodic charging of the battery with an automotive charger will extend its life.

- Keep battery and terminals clean.
- Keep battery bolts tight.
- Keep small vent holes open.
- Recharge at 6-10 amperes for 1 hour.

TO CLEAN BATTERY AND TERMINALS

Corrosion and dirt on the battery and terminals can cause the battery to "leak" power.

- Remove terminal guard.
- Disconnect BLACK battery cable first then RED battery cable and remove battery from tractor.
- Rinse the battery with plain water and dry.
- Clean terminals and battery cable ends with wire brush until bright.
- Coat terminals with grease or petroleum jelly.
- Reinstall battery (See "CONNECT BATTERY" in the Assembly section of this manual).

CUSTOMER RESPONSIBILITIES

TRANSAXLE COOLING

The fan and cooling fins of transmission should be kept clean to assure proper cooling.

Do not attempt to clean fan or transmission while engine is running or while the transmission is hot. To prevent possible damage to seals, do not use high pressure water or steam to clean transaxle.

- Inspect cooling fan to be sure fan blades are intact and clean.
- Inspect cooling fins for dirt, grass clippings and other materials. To prevent damage to seals, do not use compressed air or high pressure sprayer.

TRANSAXLE PUMP FLUID

The transaxle was sealed at the factory and fluid maintenance is not required for the life of the transaxle. Should the transaxle ever leak or require servicing, contact your nearest authorized service center/department.

V-BELTS

Check V-belts for deterioration and wear after 100 hours of operation and replace if necessary. The belts are not adjustable. Replace belts if they begin to slip from wear.

ENGINE

LUBRICATION

Only use high quality detergent oil rated with API service classification SF or SG. Select the oil's SAE viscosity grade according to your expected operating temperature.

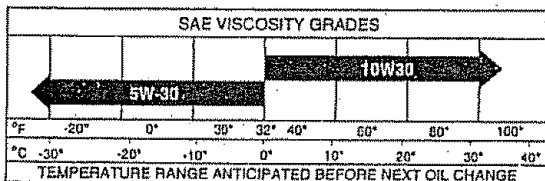

FIG. 14

NOTE: Although multi-viscosity oils (5W30, 10W30, etc) improves starting in cold weather, these multi-viscosity oils will result in increased oil consumption when used above 32°C. Check your engine oil level more frequently to avoid possible engine damage from running low on oil.

Change the oil after the first two hours of operation and every 50 hours thereafter or at least once a year if the tractor is not used for 50 hours in one year.

Check the crankcase oil level before starting the engine and after each eight (8) hours of continuous use.

TO CHANGE ENGINE OIL (See Figs. 14 and 15)

Determine temperature range expected before oil change. All oil must meet API service classification SF or SG.

- Be sure tractor is on level surface.
- Oil will drain more freely when warm.
- Catch oil in a suitable container.
- Remove oil fill cap/dipstick. Be careful not to allow dirt to enter the engine when changing oil.
- Remove drain plug.
- After oil has drained completely, replace oil drain plug and tighten securely.
- Refill engine with oil through oil fill dipstick tube. Pour slowly. Do not overfill. For approximate capacity see "PRODUCT SPECIFICATIONS" on page 3 of this manual.
- Use gauge on oil fill cap/dipstick for checking level. Be sure dipstick is in all the way for accurate reading. Keep oil at "FULL" line on dipstick.

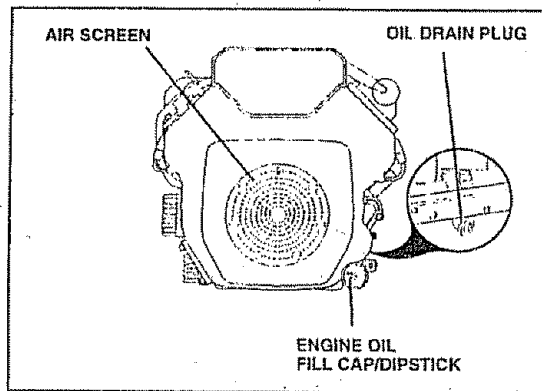

FIG. 15

CLEAN AIR SCREEN (See Fig. 15)

Air screen must be kept free of dirt and chaff to prevent engine damage from overheating. Clean with a wire brush or compressed air to remove dirt and stubborn dried gum fibers.

CUSTOMER RESPONSIBILITIES

CLEAN AIR INTAKE/COOLING AREAS

To insure proper cooling, make sure the grass screen, cooling fins, and other external surfaces of the engine are kept clean at all times.

Every 100 hours of operation (more often under extremely dusty, dirty conditions), remove the blower housing and other cooling shrouds. Clean the cooling fins and external surfaces as necessary. Make sure the cooling shrouds are reinstalled.

NOTE: Operating the engine with a blocked grass screen, dirty or plugged cooling fins, and/or cooling shrouds removed will cause engine damage due to overheating.

AIR FILTER (See Fig. 16)

Your engine will not run properly using a dirty air filter. Clean the foam pre-cleaner after every 25 hours of operation or every season. Service paper cartridge every 100 hours of operation or every season, whichever occurs first. Service air cleaner more often under dusty conditions.

- Loosen knob and remove cover.

TO SERVICE PRE-CLEANER

- Slide foam pre-cleaner off cartridge.
- Wash it in liquid detergent and water.
- Squeeze it dry in a clean cloth.
- Saturate it in engine oil. Wrap it in clean, absorbent cloth and squeeze to remove excess oil.

TO SERVICE CARTRIDGE

- Remove nut and cartridge plate.
- Gently tap the flat side of the paper cartridge to dislodge dirt. Do not wash the paper cartridge or use pressurized air, as this will damage the cartridge. Replace a dirty, bent, or damaged cartridge.
- Reinstall the pre-cleaner (cleaned and oiled) over the paper cartridge.
- Check rubber seal for damage and proper position around stud. Replace if necessary.
- Reassemble air cleaner, cartridge plate, and nut.
- Reinstall air cleaner cover and secure by tightening knob.

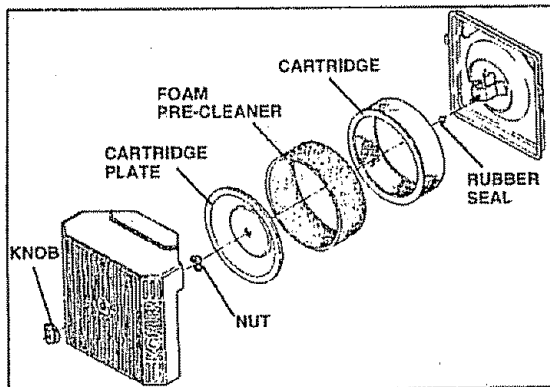

FIG. 16

ENGINE OIL FILTER

Replace the engine oil filter every season or every other oil change if the tractor is used more than 100 hours in one year.

MUFFLER

Inspect and replace corroded muffler and spark arrester (if equipped) as it could create a fire hazard and/or damage.

SPARK PLUGS

Replace spark plugs at the beginning of each mowing season or after every 100 hours of operation, whichever occurs first. Spark plug type and gap setting are shown in "PRODUCT SPECIFICATIONS" on page 3 of this manual.

IN-LINE FUEL FILTER (See Fig. 17)

The fuel filter should be replaced once each season. If fuel filter becomes clogged, obstructing fuel flow to carburetor, replacement is required.

- With engine cool, remove filter and plug fuel line sections.
- Place new fuel filter in position in fuel line with arrow pointing towards carburetor.
- Be sure there are no fuel line leaks and clamps are properly positioned.
- Immediately wipe up any spilled gasoline.

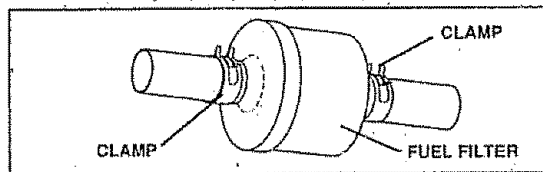

FIG. 17

CLEANING

- Clean engine, battery, seat, finish, etc. of all foreign matter.
- Keep finished surfaces and wheels free of all gasoline, oil, etc.
- Protect painted surfaces with automotive type wax.

We do not recommend using a garden hose to clean your tractor unless the electrical system, muffler, air filter and carburetor are covered to keep water out. Water in engine can result in a shortened engine life.

SERVICE AND ADJUSTMENTS



CAUTION: BEFORE PERFORMING ANY SERVICE OR ADJUSTMENTS:

- Depress clutch/brake pedal fully and set parking brake.
- Place motion control lever in neutral (N) position.
- Place attachment clutch in "DISENGAGED" position.
- Turn ignition key "OFF" and remove key.
- Make sure the blades and all moving parts have completely stopped.
- Disconnect spark plug wire from spark plug and place wire where it cannot come in contact with plug.

TRACTOR

TO REMOVE MOWER (See Fig. 18)

- Place attachment clutch in "DISENGAGED" position.
- Turn height adjustment knob to lowest setting.
- Lower mower to its lowest position.
- Remove retainer spring holding anti-swaybar to chassis bracket and disengage anti-swaybar from bracket.
- Remove retainer springs from suspension arms at deck and disengage arms from deck.
- Raise attachment lift to its highest position.
- Remove two retainer springs from each front link and remove links.
- Slide mower forward and remove belt from electric clutch pulley.
- Slide mower out from under right side of tractor.

IMPORTANT: IF AN ATTACHMENT OTHER THAN THE MOWER DECK IS TO BE MOUNTED ON THE TRACTOR, REMOVE THE FRONT LINKS.

TO INSTALL MOWER

Follow procedure described in "INSTALL MOWER AND DRIVE BELT" in the Assembly section of this manual.

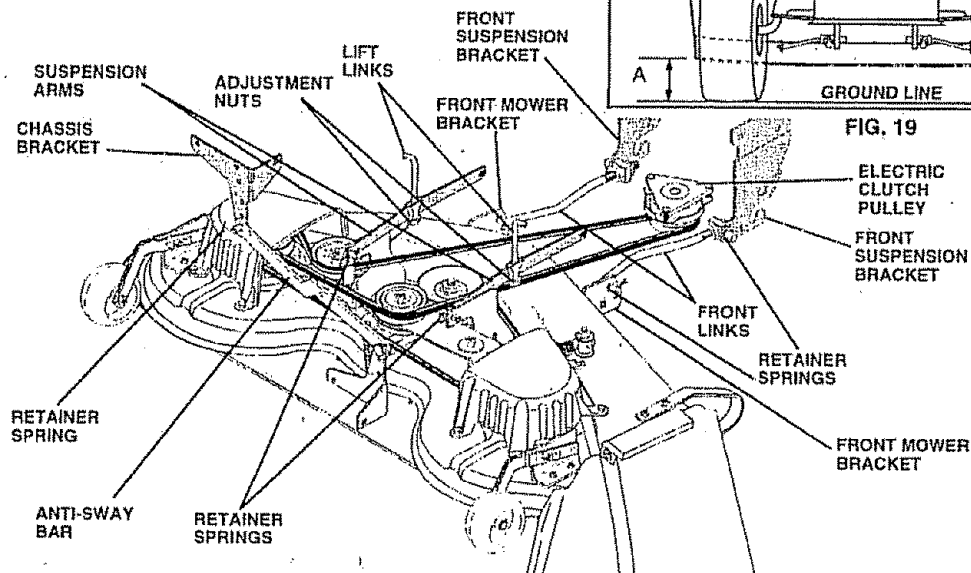

FIG. 18

TO LEVEL MOWER HOUSING

Adjust the mower while tractor is parked on level ground or driveway. Make sure tires are properly inflated (See "PRODUCT SPECIFICATIONS" on page 3 of this manual). If tires are over or underinflated, you will not properly adjust your mower.

SIDE-TO-SIDE ADJUSTMENT (See Figs 18 and 19)

- Raise mower to its highest position.
- Measure height from bottom of deck curl to ground level at front corners of mower. Distance "A" on both sides of mower should be the same.
- If adjustment is necessary, make adjustment on one side of mower only.
- To raise one side of mower, tighten lift link adjustment nut on that side.
- To lower one side of mower, loosen lift link adjustment nut on that side.

NOTE: Each half turn of adjustment nut will change mower height about 3/16".

- Recheck measurements after adjusting.

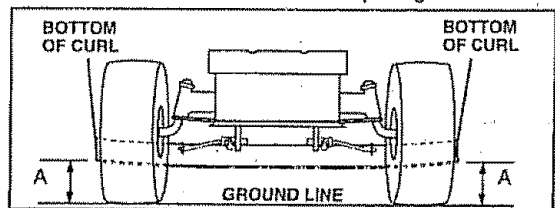

FIG. 19

SERVICE AND ADJUSTMENTS

FRONT-TO-BACK ADJUSTMENT (See Figs. 20 and 21) -

IMPORTANT: DECK MUST BE LEVEL SIDE-TO-SIDE. IF THE FOLLOWING FRONT-TO-BACK ADJUSTMENT IS NECESSARY, BE SURE TO ADJUST BOTH FRONT LINKS EQUALLY SO MOWER WILL STAY LEVEL SIDE-TO-SIDE

To obtain the best cutting results, the mower housing should be adjusted so the front is approximately 1/8" to 1/2" lower than the rear when the mower is in its highest position.

Check adjustment on right side of tractor. Measure distance "F" directly in front of and behind the mandrel at bottom edge of mower housing as shown.

- Before making any necessary adjustments, check that both front links are equal in length
- If links are not equal in length, adjust one link to same length as other link
- To lower front of mower housing, loosen nut "G" on both front links an equal number of turns
- When distance "F" is 1/8" to 1/2" lower at front than rear, tighten nut "H" against trunnion on both front links.
- To raise front of mower housing, loosen nut "H" from trunnion on both front links. Tighten nut "G" on both front links an equal number of turns
- When distance "F" is 1/8" to 1/2" lower at front than rear, tighten nut "H" against trunnion on both front links.

NOTE: Each full turn of nut "G" will change dim. "F" by approximately 3/8".

- Recheck side-to-side adjustment.

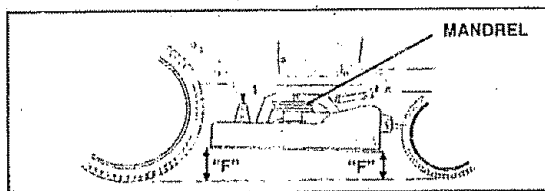

FIG. 20

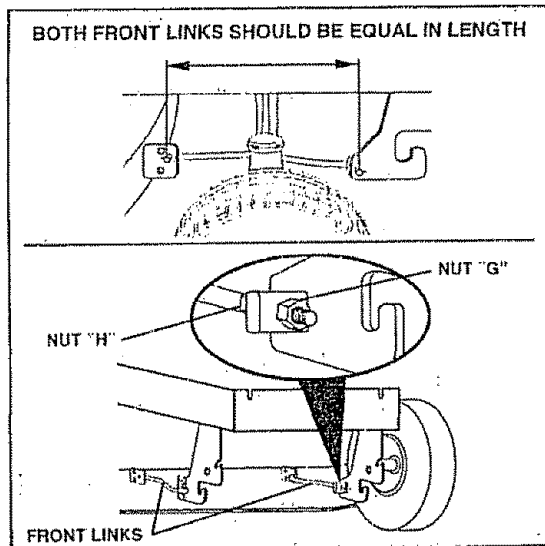

FIG. 21

TO REPLACE MOWER DRIVE BELT

MOWER DRIVE BELT REMOVAL (See Fig. 22) -

- Park tractor on a level surface. Engage parking brake.
- Remove four screws from L.H. mandrel cover and remove cover.
- Roll belt over the top of L.H. mandrel pulley.
- Remove belt from electric clutch pulley.
- Remove belt from idler pulleys
- Remove any dirt or grass clippings which may have accumulated around mandrels and entire upper deck surface.
- Check primary idler arm and two idlers to see that they rotate freely.
- Be sure spring is securely hooked to primary idler arm and bolt in mower housing.

MOWER DRIVE BELT INSTALLATION (See Fig. 22) -

- Install belt in both idlers. Make sure belt is in both belt keepers at the idlers as shown.
- Install new belt onto electric clutch pulley.
- Roll belt into upper groove of L.H. mandrel pulley.
- Carefully check belt routing making sure belt is in the grooves correctly and inside belt keepers.
- Reassemble L.H. mandrel cover.

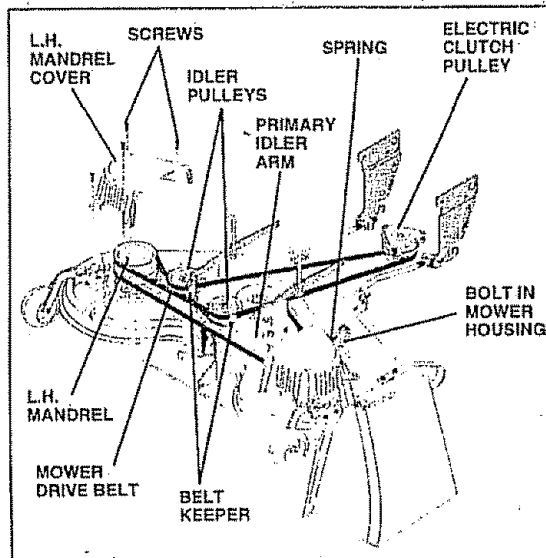

FIG. 22

SERVICE AND ADJUSTMENTS

TO REPLACE MOWER BLADE DRIVE BELT (See Fig. 23)

Park the tractor on level surface. Engage parking brake.

- Remove mower drive belt (See "TO REPLACE MOWER DRIVE BELT" in this section of this manual)
- Remove mower (See "TO REMOVE MOWER" in this section of this manual)
- Remove four screws from R.H. mandrel cover and remove cover. Unhook spring from bolt on mower housing.
- Carefully roll belt off R.H. mandrel pulley.
- Remove belt from center mandrel pulley, idler pulley, and L.H. mandrel pulley.
- Remove any dirt or grass which may have accumulated around mandrels and entire upper deck surface.
- Check secondary idler arm and idler to see that they rotate freely.
- Be sure spring is hooked in secondary idler arm and sway-bar bracket.
- Install new belt in lower groove of L.H. mandrel pulley, idler pulley, and center mandrel pulley as shown.
- Roll belt over R.H. mandrel pulley. Make sure belt is in all grooves properly.
- Reconnect spring to bolt in mower housing and reinstall R.H. mandrel cover.
- Reinstall mower to tractor (See "INSTALL MOWER AND DRIVE BELT" in the Assembly section of this manual)
- Reassemble mower drive belt (See "TO REPLACE MOWER DRIVE BELT" in this section of this manual).

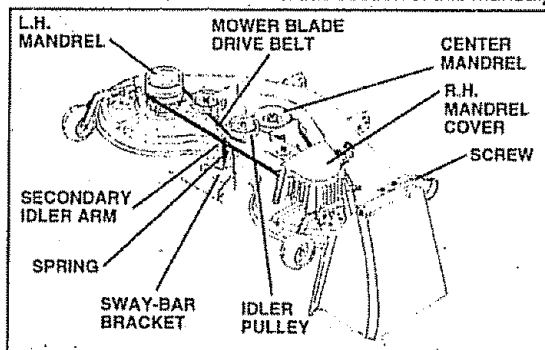

FIG. 23

TO ADJUST ATTACHMENT CLUTCH (See Fig. 24)

The electric clutch should provide years of service. The clutch has a built-in brake that stops the pulley within 5 seconds. Eventually, the internal brake will wear which may cause the mower blades to not engage, or, to not stop as required. Adjustments should be made by your nearest authorized service center/department.

- Make sure attachment clutch and ignition switches are in "OFF" position.
- Adjust the three nylon locknuts until space between clutch plate and rotor measures .012" at all three slot locations cut in side of brake plate.

NOTE: After installing a new electric clutch, run tractor at full throttle and engage and disengage electric clutch 10 cycles to wear in clutch plate.

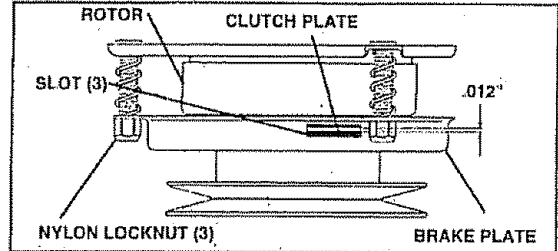

FIG. 24

TO ADJUST BRAKE (See Fig. 25)

Your tractor is equipped with an adjustable brake system which is mounted on the side of the transaxle.

If tractor requires more than six (6) feet stopping distance at high speed in highest gear, then brake must be adjusted.

- Depress clutch/brake pedal and engage parking brake.
- Measure distance between brake operating arm and nut "A" on brake rod.
- If distance is other than 1-1/2", loosen jam nut and turn nut "A" until distance becomes 1-1/2". Retighten jam nut against nut "A".
- Road test tractor for proper stopping distance as stated above. Readjust if necessary. If stopping distance is still greater than six (6) feet in highest gear, further maintenance is necessary. Contact your nearest authorized service center/department

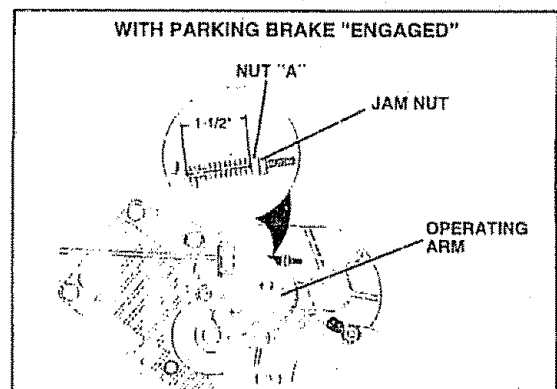

FIG. 25

SERVICE AND ADJUSTMENTS

TO REPLACE MOTION DRIVE BELT (See Fig. 26)

Park the tractor on level surface. Engage parking brake. For ease of service there is a belt installation guide decal on bottom of left footrest.

- Remove mower (See "TO REMOVE MOWER" in this section of this manual.)

BELT REMOVAL -

- Engage parking brake (creates slack in belt).
- Remove belt from clutching and fan idler pulleys.
- Remove belt from transaxle pulley.
- Remove belt from engine pulley and front V-idler pulley.
- Pull belt out of all belt keepers and remove from tractor.

BELT INSTALLATION -

- Place V part of belt into grooves on engine pulley and front V-idler, making sure to route belt inside of all belt keepers.
- Route belt on right side, coming from V-idler, towards back of tractor, above midspan belt keeper and to top of transaxle pulley.
- Route belt on left side, coming from engine pulley, towards back of tractor and through loop in midspan belt keeper.
- Place V part of belt into grooves on transaxle and fan idler pulleys, making sure to route belt inside of all belt keepers.
- Place belt around clutching idlers as shown, making sure to route belt inside of all belt keepers.
- Check to be sure belt is positioned correctly and is on proper side of all belt keepers.
- Reinstall mower.

IMPORTANT: CHECK BRAKE ADJUSTMENT.

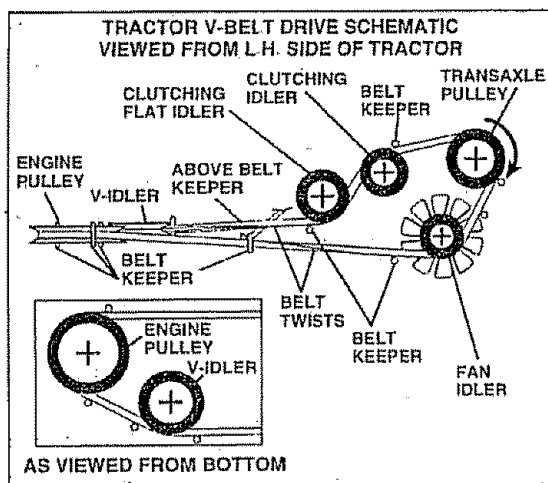

FIG. 26

TO ADJUST MOTION CONTROL LEVER (See Fig. 27)

The motion control lever has been preset at the factory and adjustment should not be necessary.

If for any reason the motion control lever will not hold its position while at a selected speed, it may be adjusted at the friction pack located on the right side of chassis.

- Park tractor on level surface. Stop tractor by turning ignition key to "OFF" position and engage parking brake.
- Place motion control lever in neutral (N) position.
- While holding locknut, loosen jam nut.
- Tighten locknut 1/4 turn.
- While holding locknut, tighten jam nut securely.

NOTE: If for any reason the effort to move the motion control lever becomes too excessive, reverse the above adjustment procedure by loosening locknut 1/4 turn.

Road test tractor after adjustment and repeat procedure if necessary.

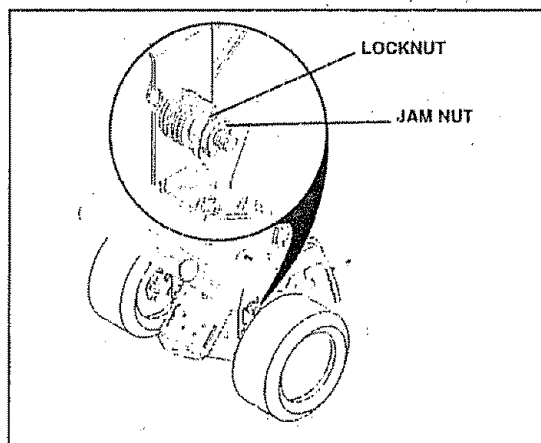

FIG. 27

TRANSMISSION REMOVAL/REPLACEMENT

Should your transmission require removal for service or replacement, it should be purged after reinstallation before operating the tractor. See "PURGE TRANSMISSION" in Operation section of this manual.

TO ADJUST STEERING WHEEL ALIGNMENT

If steering wheel crossbars are not horizontal (left to right) when wheels are positioned straight forward, remove steering wheel and reassemble per instructions in the Assembly section of this manual.

SERVICE AND ADJUSTMENTS

FRONT WHEEL TOE-IN ADJUSTMENT

Front wheel toe-in is required for proper steering operation. Toe-in was set at the factory and adjustment should not be necessary. If parts in the front axle or steering mechanism have been replaced or damaged, check toe-in and adjust if necessary.

TO CHECK TOE-IN (See Fig. 28) -

- Position front wheels straight ahead
- Measure distance between wheels at front and rear of tires (dimensions "A" and "B").
- Front dimension "A" should be 1/8" to 1/4" less than rear dimension "B".

TO ADJUST TOE-IN (See Figs. 28 and 29) -

- Loosen jam nuts at adjustment sleeves on tie rod.
- Adjust tie rod until dimension "A" is 1/8" to 1/4" less than dimension "B".
- Tighten jam nuts securely.

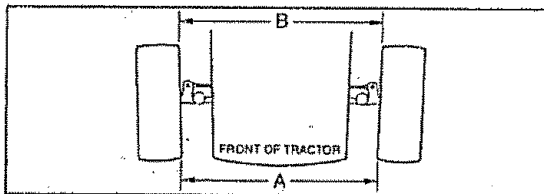

FIG. 28

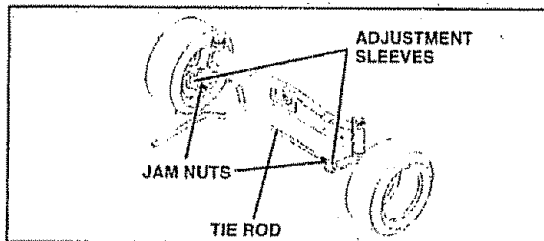

FIG. 29

FRONT WHEEL CAMBER

The front wheel camber is not adjustable on your tractor. If damage has occurred to affect the front wheel camber, contact your nearest authorized service center/department.

TO REMOVE WHEEL FOR REPAIRS

FRONT WHEEL (See Fig. 30) -

- Block up axle securely.
- Remove axle cover, retaining ring and washers to allow wheel removal.
- Repair tire and reassemble.
- Replace washers and snap retaining ring securely in axle groove.
- Replace axle cover.

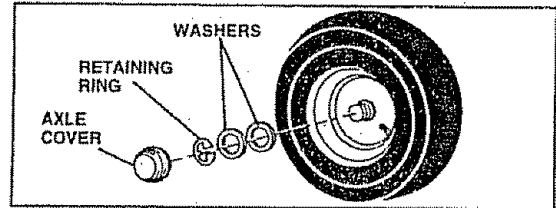

FIG. 30

REAR WHEEL -

- Block rear axle securely
- Remove five (5) hub bolts to allow wheel removal.
- Repair tire and reassemble. Replace and tighten hub bolts securely

TO START ENGINE WITH A WEAK BATTERY (See Fig. 31)



CAUTION: Lead-acid batteries generate explosive gases. Keep sparks, flame and smoking materials away from batteries. Always wear eye protection when around batteries.

If your battery is too weak to start the engine, it should be recharged. If "jumper cables" are used for emergency starting, follow this procedure:

IMPORTANT: YOUR TRACTOR IS EQUIPPED WITH A 12 VOLT NEGATIVE GROUNDED SYSTEM. THE OTHER VEHICLE MUST ALSO BE A 12 VOLT NEGATIVE GROUNDED SYSTEM. DO NOT USE YOUR TRACTOR BATTERY TO START OTHER VEHICLES.

TO ATTACH JUMPER CABLES -

- Connect each end of the RED cable to the POSITIVE (+) terminal of each battery, taking care not to short against chassis.
- Connect one end of the BLACK cable to the NEGATIVE (-) terminal of fully charged battery.
- Connect the other end of the BLACK cable to good CHASSIS GROUND, away from fuel tank and battery.

TO REMOVE CABLES, REVERSE ORDER -

- BLACK cable first from chassis and then from the fully charged battery
- RED cable last from both batteries.

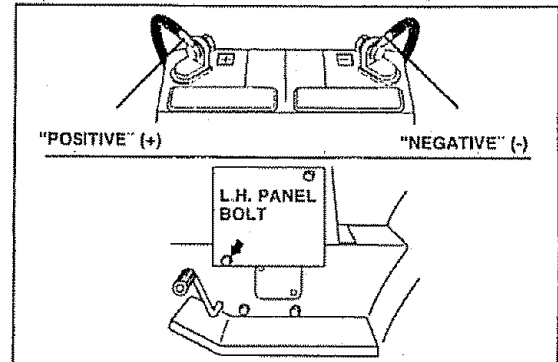

FIG. 31

SERVICE AND ADJUSTMENTS

TO REPLACE HEADLIGHT BULB

- Raise hood.
- Pull bulb holder out of the hole in the backside of the grill.
- Replace bulb in holder and push bulb holder securely back into the hole in the backside of the grill.
- Close hood.

INTERLOCKS AND RELAYS

Loose or damaged wiring may cause your tractor to run poorly, stop running, or prevent it from starting.

- Check wiring. See electrical wiring diagram in the Repair Parts section of this manual.

TO REPLACE FUSE

Replace with 30 amp automotive-type plug-in fuse. The fuse holder is located behind the dash.

TO ADJUST ATTACHMENT LIFT SPRING (See Fig. 32)

- While holding spring bushing with wrench, loosen jam nut.
- Turn adjustment bolt clockwise to extend spring and reduce lift effort for heavier attachments.
- Turn adjustment bolt counterclockwise for lighter attachments.
- Retighten jam nut against spring bushing.

IMPORTANT: DO NOT ADJUST FOR MAXIMUM SPRING TENSION WHEN USING LIGHT ATTACHMENTS SUCH AS A MOWER. ADJUST LIFT LEVER SPRING TO AID IN LIFTING ATTACHMENT. DO NOT OVERPOWER SPRING. WHEN REMOVING ATTACHMENT, ALWAYS ADJUST SPRING TENSION TO ITS LOWEST POSITION.

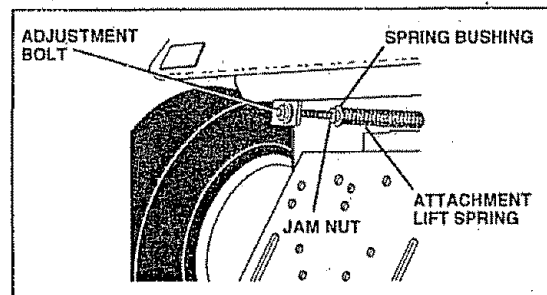

FIG. 32

TO REMOVE HOOD AND GRILL ASSEMBLY (See Fig. 33)

- Raise hood.
- Unsnap headlight wire connector.
- Stand in front of tractor. Grasp hood at sides, tilt toward engine and lift off of tractor.
- To replace, reverse above procedures.

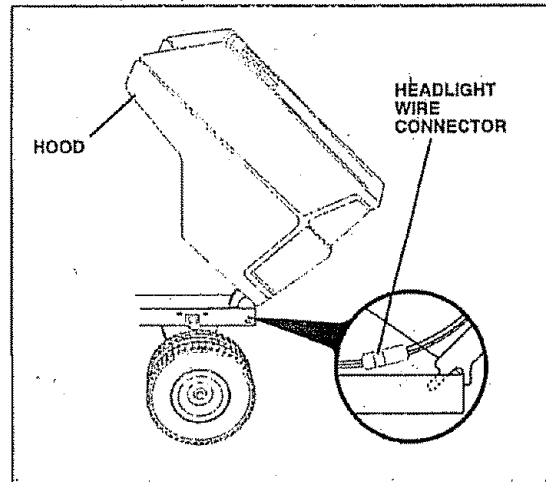

FIG. 33

ENGINE

TO ADJUST THROTTLE CONTROL CABLE (See Fig. 34)

The throttle control has been preset at the factory and adjustment should not be necessary. Check adjustment as described below before loosening cable. If adjustment is necessary, proceed as follows:

- With engine not running, move throttle control lever to fast (F) position.
- Check that speed control lever is against stop screw. If it is not, loosen casing clamp screw and pull throttle cable until lever is against screw. Tighten clamp screw securely.

SERVICE AND ADJUSTMENTS

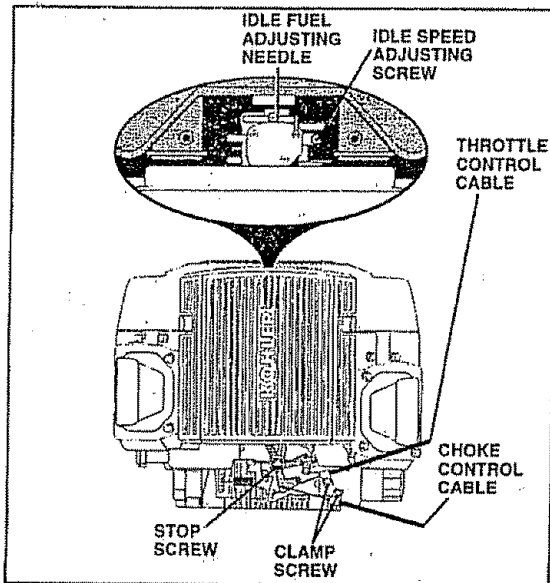

FIG. 34

TO ADJUST CHOKE CONTROL (See Figs. 34 and 35)

The choke control has been preset at the factory and adjustment should not be necessary. Check adjustment as described below before loosening cable. If adjustment is necessary, proceed as follows:

- With engine not running, move choke control (located on dash panel) to full choke (N) position.
- Remove air cleaner cover, filter and cartridge plate to expose carburetor choke (See "AIR FILTER" in the Customer Responsibilities section of this manual).
- Choke should be closed. If it is not, loosen casing clamp screw and move choke cable until choke is completely closed. Tighten casing clamp screw securely.
- Reassemble air cleaner.

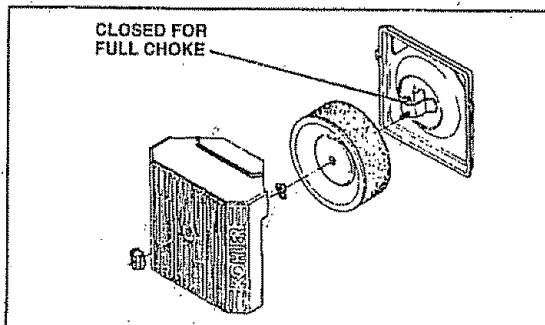

FIG. 35

TO ADJUST CARBURETOR (See Fig. 34)

The carburetor has been preset at the factory and adjustment should not be necessary. However, minor adjustment may be required to compensate for differences in fuel, temperature, altitude or load. If the carburetor does need adjustment, proceed as follows:

In general, turning the adjusting needles in (clockwise) decreases the supply of fuel to the engine giving a leaner fuel/air mixture. Turning the adjusting needles out (counterclockwise) increases the supply of fuel to the engine giving a richer fuel/air mixture.

IMPORTANT: DAMAGE TO THE NEEDLES AND THE SEATS IN CARBURETOR MAY RESULT IF SCREW IS TURNED IN TOO TIGHT.

PRELIMINARY SETTING -

- Be sure you have a clean air filter, and the throttle control cable is adjusted properly (see "TO ADJUST THROTTLE CONTROL CABLE" in the Service and Adjustments section of this manual).
- With engine off turn idle fuel adjusting needle in (clockwise) closing it finger tight and then turn out (counterclockwise) 1 turn.

FINAL SETTING -

- Start engine and allow to warm for five minutes. Make final adjustments with engine running and shift/motion control lever in neutral (N) position.
- The high idle is set at the factory and cannot be adjusted.
- **Idle speed setting** - With throttle control lever in slow (S) position, engine should idle at 1200 RPM. If engine idles too slow or fast, turn idle speed adjusting screw in or out until correct idle is attained.
- **Idle fuel needle setting** - With throttle control lever in slow (S) position, turn idle fuel adjusting needle in (clockwise) until engine speed decreases and then turn out (counterclockwise) approximately 3/4 turn to obtain the best low speed performance.
- Recheck idle speed. Readjust if necessary.

ACCELERATION TEST -

- Move throttle control lever from slow (S) to fast (F) position. If engine hesitates or dies, turn idle fuel adjusting needle out (counterclockwise) 1/8 turn. Repeat test and continue to adjust, if necessary, until engine accelerates smoothly.

High speed stop is factory adjusted. Do not adjust-damage may result.

IMPORTANT: NEVER TAMPER WITH THE ENGINE GOVERNOR, WHICH IS FACTORY SET FOR PROPER ENGINE SPEED. OVERSPEEDING THE ENGINE ABOVE THE FACTORY HIGH SPEED SETTING CAN BE DANGEROUS. IF YOU THINK THE ENGINE-GOVERNED HIGH SPEED NEEDS ADJUSTING, CONTACT YOUR NEAREST AUTHORIZED SERVICE CENTER/DEPARTMENT, WHICH HAS PROPER EQUIPMENT AND EXPERIENCE TO MAKE ANY NECESSARY ADJUSTMENTS

STORAGE

Immediately prepare your tractor for storage at the end of the season or if the tractor will not be used for 30 days or more.



CAUTION: Never store the tractor with gasoline in the tank inside a building where fumes may reach an open flame or spark. Allow the engine to cool before storing in any enclosure.

TRACTOR

Remove mower from tractor for winter storage. When mower is to be stored for a period of time, clean it thoroughly, remove all dirt, grease, leaves, etc. Store in a clean, dry area.

- Clean entire tractor (See "CLEANING" in the Customer Responsibilities section of this manual).
- Inspect and replace belts, if necessary (See belt replacement instructions in the Service and Adjustments section of this manual).
- Lubricate as shown in the Customer Responsibilities section of this manual.
- Be sure that all nuts, bolts and screws are securely fastened. Inspect moving parts for damage, breakage and wear. Replace if necessary.
- Touch up all rusted or chipped paint surfaces; sand lightly before painting.

BATTERY

- Fully charge the battery for storage.
- After a period of time in storage, battery may require recharging.
- To help prevent corrosion and power leakage during long periods of storage, battery cables should be disconnected and battery cleaned thoroughly (see "TO CLEAN BATTERY AND TERMINALS" in the Customer Responsibilities section of this manual).
- After cleaning, leave cables disconnected and place cables where they cannot come in contact with battery terminals.
- Be sure battery drain tube is securely attached.
- If battery is removed from tractor for storage, do not store battery directly on concrete or damp surfaces.

ENGINE

FUEL SYSTEM

IMPORTANT: IT IS IMPORTANT TO PREVENT GUM DEPOSITS FROM FORMING IN ESSENTIAL FUEL SYSTEM PARTS SUCH AS CARBURETOR, FUEL FILTER, FUEL HOSE, OR TANK DURING STORAGE. ALSO, EXPERIENCE INDICATES THAT ALCOHOL BLENDED FUELS (CALLED GASOHOL OR USING ETHANOL OR METHANOL) CAN ATTRACT MOISTURE WHICH LEADS TO SEPARATION AND FORMATION OF ACIDS DURING STORAGE. ACIDIC GAS CAN DAMAGE THE FUEL SYSTEM OF AN ENGINE WHILE IN STORAGE.

- Drain the fuel tank.
- Start the engine and let it run until the fuel lines and carburetor are empty.
- Never use engine or carburetor cleaner products in the fuel tank or permanent damage may occur.
- Use fresh fuel next season.

NOTE: Fuel stabilizer is an acceptable alternative in minimizing the formation of fuel gum deposits during storage. Add stabilizer to gasoline in fuel tank or storage container. Always follow the mix ratio found on stabilizer container. Run engine at least 10 minutes after adding stabilizer to allow the stabilizer to reach the carburetor. Do not drain the gas tank and carburetor if using fuel stabilizer.

ENGINE OIL

Drain oil (with engine warm) and replace with clean engine oil. (See "ENGINE" in the Customer Responsibilities section of this manual)

CYLINDERS

- Remove spark plug(s)
- Pour one ounce of oil through spark plug hole(s) into cylinder(s).
- Turn ignition key to "START" position for a few seconds to distribute oil.
- Replace with new spark plug(s)

OTHER

- Do not store gasoline from one season to another.
- Replace your gasoline can if your can starts to rust. Rust and/or dirt in your gasoline will cause problems.
- If possible, store your tractor indoors and cover it to give protection from dust and dirt.
- Cover your tractor with a suitable protective cover that does not retain moisture. Do not use plastic. Plastic cannot breathe which allows condensation to form and will cause your tractor to rust.

IMPORTANT: NEVER COVER TRACTOR WHILE ENGINE AND EXHAUST ARE STILL WARM.

TROUBLESHOOTING POINTS

PROBLEM	CAUSE	CORRECTION
Will not start	<ol style="list-style-type: none"> 1. Out of fuel. 2. Engine not "CHOKED" properly 3. Engine flooded 4. Bad spark plug 5. Dirty air filter 6. Dirty fuel filter 7. Water in fuel 8. Loose or damaged wiring 9. Carburetor out of adjustment. 10. Engine valves out of adjustment. 	<ol style="list-style-type: none"> 1. Fill fuel tank 2. See "TO START ENGINE" in Operation section. 3. Wait several minutes before attempting to start. 4. Replace spark plug. 5. Clean/replace air filter. 6. Replace fuel filter. 7. Drain fuel tank and carburetor, refill tank with fresh gasoline and replace fuel filter 8. Check all wiring. 9. See "To Adjust Carburetor" in Service Adjustments section. 10. Contact an authorized service center/department.
Hard to start	<ol style="list-style-type: none"> 1. Dirty air filter 2. Bad spark plug. 3. Weak or dead battery 4. Dirty fuel filter 5. Stale or dirty fuel 6. Loose or damaged wiring. 7. Carburetor out of adjustment 8. Engine valves out of adjustment. 	<ol style="list-style-type: none"> 1. Clean/replace air filter 2. Replace spark plug 3. Recharge or replace battery 4. Replace fuel filter 5. Drain fuel tank and refill with fresh gasoline 6. Check all wiring. 7. See "To Adjust Carburetor" in Service Adjustments section. 8. Contact an authorized service center/department.
Engine will not turn over	<ol style="list-style-type: none"> 1. Clutch/brake pedal not depressed 2. Attachment clutch is engaged 3. Weak or dead battery. 4. Blown fuse. 5. Corroded battery terminals 6. Loose or damaged wiring 7. Faulty ignition switch. 8. Faulty solenoid or starter. 9. Faulty operator presence switch(es). 	<ol style="list-style-type: none"> 1. Depress clutch/brake pedal 2. Disengage attachment clutch. 3. Recharge or replace battery 4. Replace fuse 5. Clean battery terminals: 6. Check all wiring. 7. Check/replace ignition switch. 8. Check/replace solenoid or starter. 9. Contact an authorized service center/department
Engine clicks but will not start	<ol style="list-style-type: none"> 1. Weak or dead battery 2. Corroded battery terminals 3. Loose or damaged wiring. 4. Faulty solenoid or starter. 	<ol style="list-style-type: none"> 1. Recharge or replace battery 2. Clean battery terminals 3. Check all wiring. 4. Check/replace solenoid or starter.
Loss of power	<ol style="list-style-type: none"> 1. Cutting too much grass/too fast. 2. Throttle in "CHOKE" position. 3. Build-up of grass, leaves and trash under mower. 4. Dirty air filter. 5. Low oil level/dirty oil. 6. Faulty spark plug 7. Dirty fuel filter 8. Stale or dirty fuel 9. Water in fuel 10. Spark plug wire loose. 11. Dirty engine air screen/fins. 12. Dirty/clogged muffler 13. Loose or damaged wiring 14. Carburetor out of adjustment 15. Engine valves out of adjustment. 	<ol style="list-style-type: none"> 1. Set in "Higher Cut" position/reduce speed. 2. Adjust throttle control 3. Clean underside of mower housing 4. Clean/replace air filter 5. Check oil level/change oil 6. Clean and regap or change spark plug. 7. Replace fuel filter. 8. Drain fuel tank and refill with fresh gasoline. 9. Drain fuel tank and carburetor, refill tank with fresh gasoline and replace fuel filter 10. Connect and tighten spark plug wire. 11. Clean engine air screen/fins. 12. Clean/replace muffler 13. Check all wiring. 14. See "To Adjust Carburetor" in Service Adjustments section. 15. Contact an authorized service center/department.
Excessive vibration	<ol style="list-style-type: none"> 1. Worn, bent or loose blade 2. Bent blade mandrel. 3. Loose/damaged part(s). 	<ol style="list-style-type: none"> 1. Replace blade Tighten blade bolt. 2. Replace blade mandrel. 3. Tighten loose part(s) Replace damaged parts



TROUBLESHOOTING POINTS

PROBLEM	CAUSE	CORRECTION
Engine continues to run when operator leaves seat with attachment clutch engaged	<ol style="list-style-type: none"> 1. Faulty operator-safety presence control system 	<ol style="list-style-type: none"> 1. Check wiring, switches and connections. If not corrected, contact an authorized service center/department
Poor cut - uneven	<ol style="list-style-type: none"> 1. Worn, bent or loose blade. 2. Mower deck not level 3. Buildup of grass, leaves, and trash under mower. 4. Bent blade mandrel 5. Clogged mower deck vent holes from buildup of grass, leaves, and trash around mandrels 	<ol style="list-style-type: none"> 1. Replace blade. Tighten blade bolt 2. Level mower deck. 3. Clean underside of mower housing. 4. Replace blade mandrel 5. Clean around mandrels to open vent holes
Mower blades will not rotate	<ol style="list-style-type: none"> 1. Obstruction in clutch mechanism. 2. Worn/damaged mower drive belt 3. Frozen idler pulley. 4. Frozen blade mandrel 	<ol style="list-style-type: none"> 1. Remove obstruction 2. Replace mower drive belt. 3. Replace idler pulley. 4. Replace blade mandrel
Poor grass discharge	<ol style="list-style-type: none"> 1. Engine speed too slow. 2. Travel speed too fast. 3. Wet grass. 4. Mower deck not level. 5. Low/uneven tire air pressure 6. Worn, bent or loose blade. 7. Buildup of grass, leaves and trash under mower. 8. Mower drive belt worn. 9. Blades improperly installed. 10. Improper blades used. 11. Clogged mower deck vent holes from buildup of grass, leaves, and trash around mandrels 	<ol style="list-style-type: none"> 1. Place throttle control in "FAST" position 2. Shift to slower speed. 3. Allow grass to dry before mowing. 4. Level mower deck. 5. Check tires for proper air pressure. 6. Replace/sharpen blade. Tighten blade bolt 7. Clean underside of mower housing 8. Replace mower drive belt. 9. Reinstall blades sharp edge down 10. Replace with blades listed in this manual 11. Clean around mandrels to open vent holes
Headlight(s) not working (if so equipped)	<ol style="list-style-type: none"> 1. Switch is "OFF". 2. Bulb(s) burned out 3. Faulty light switch. 4. Loose or damaged wiring. 5. Blown fuse 	<ol style="list-style-type: none"> 1. Turn switch "ON" 2. Replace bulb(s) 3. Check/replace light switch 4. Check wiring and connections. 5. Replace fuse
Battery will not charge	<ol style="list-style-type: none"> 1. Bad battery cell(s). 2. Poor cable connections 3. Faulty regulator (if so equipped) 4. Faulty alternator. 	<ol style="list-style-type: none"> 1. Replace battery. 2. Check/clean all connections 3. Replace regulator. 4. Replace alternator.
Loss of drive	<ol style="list-style-type: none"> 1. Freewheel control in "disengaged" position 2. Motion drive belt worn, damaged, or broken 3. Air trapped in transmission during shipment or servicing 	<ol style="list-style-type: none"> 1. Place freewheel control in "engaged" position 2. Replace motion drive belt. 3. Purge transmission
Engine "backfires" when turning engine "OFF"	<ol style="list-style-type: none"> 1. Engine throttle control not set at "SLOW" position for 30 seconds before stopping engine. 	<ol style="list-style-type: none"> 1. Move throttle control to "SLOW" position and allow to idle for 30 seconds before stopping engine.



TRACTOR -- MODEL NUMBER 917.251561

SCHEMATIC

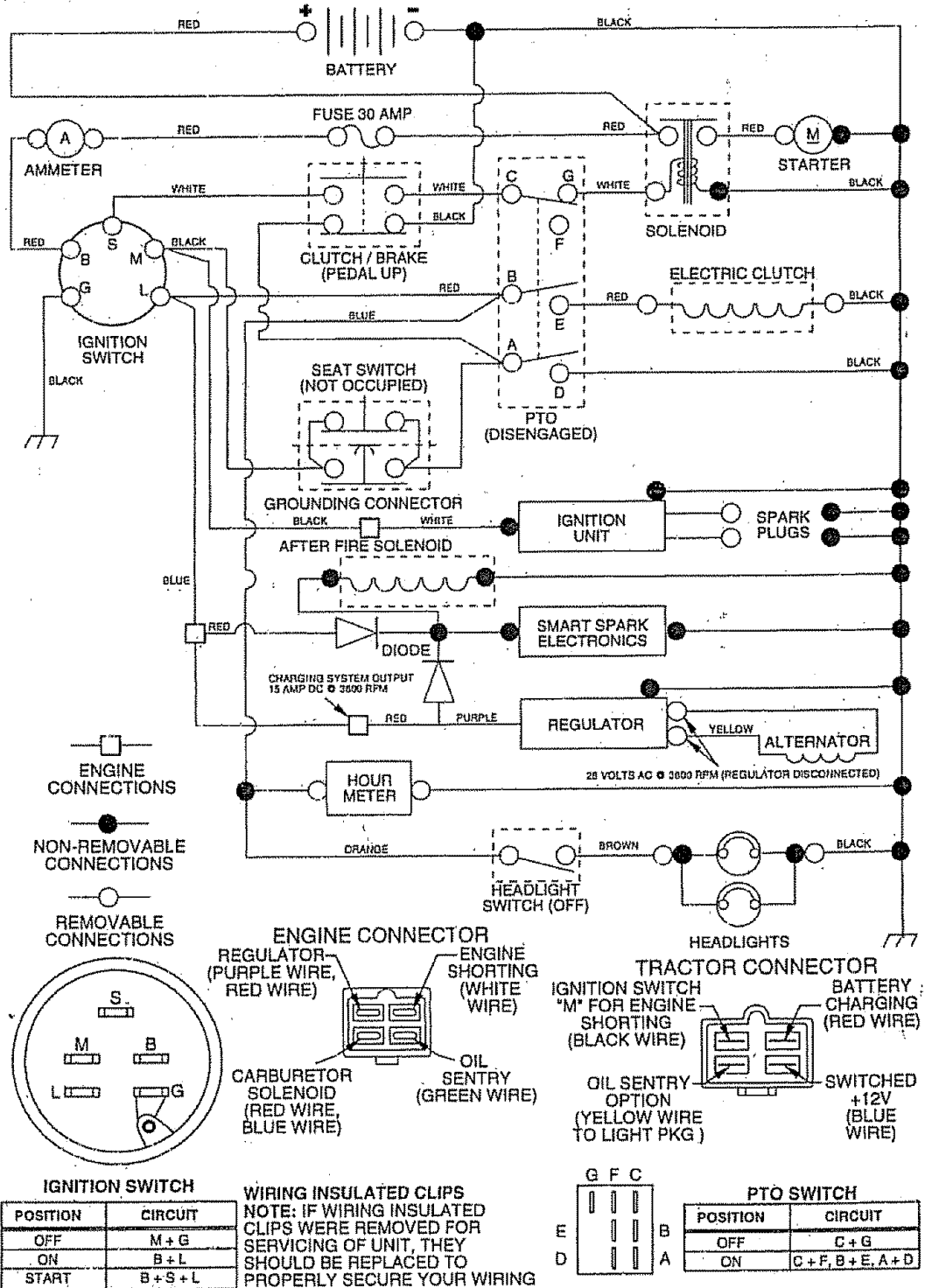

REPAIR PARTS

TRACTOR -- MODEL NUMBER 917.251561

ELECTRICAL

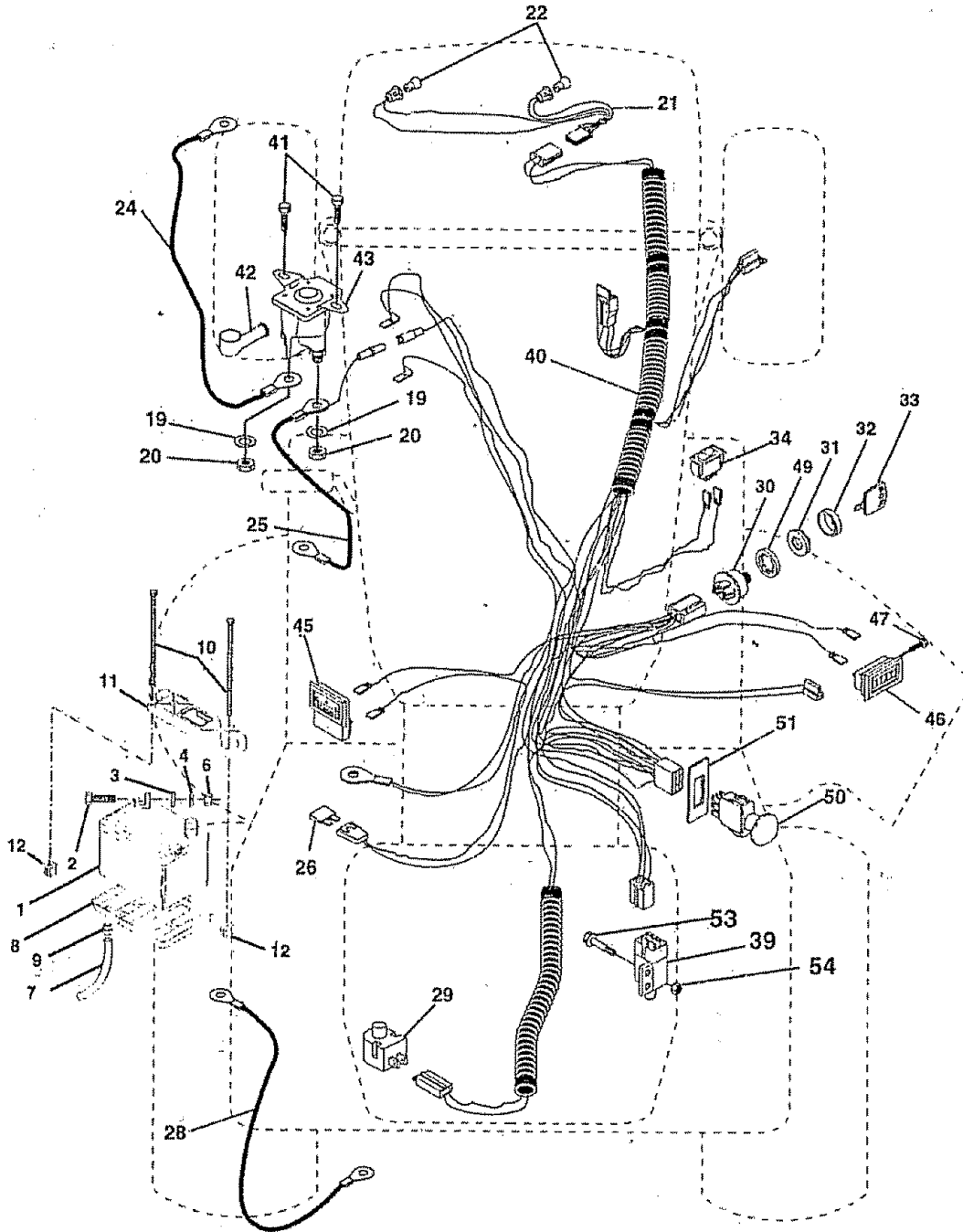

REPAIR PARTS

TRACTOR -- MODEL NUMBER 917.251561

ELECTRICAL

KEY NO.	PART NO.	DESCRIPTION
1	146141	Battery
2	74760412	Bolt Hex Head 1/4-20 x 3/4
3	STD551125	Washer, Lock 1/4
4	STD551025	Washer 9/32 x 5/8 x 16 Ga
6	STD541025	Nut Flt Hex 1/4-20
7	7697J	Tube Plastic
8	7603J	Tray, Battery
9	109596X	Clamp, Hose
10	145211	Bolt Wet BTR 1/4-20 x 7 5 Zinc
11	145209	Hold down Battery Dash Mount
12	145769	Nut Push Nylon 1/4" Wet Battery
19	STD551125	Washer, Lock 1/4
20	73350400	Nut, Jam Hex 1/4-20
21	136850	Harness Socket Light W/4152J
22	4152J	Bulb Light
24	4014J	Cable Battery 4 Ga. 22" Red
25	146686	Cable Battery Red 4 Ga. w/16 Wire
26	108824X	Fuse
28	6408R	Cable Battery 4 Gauge 12"
29	121305X	Switch, Plunger
30	144921	Switch, Ign
31	140400	Nut, Ignition Switch
32	141226	Cover Switch Key
33	140403	Key
34	110712X	Switch, Light
39	109553X	Intlk Switch
40	151730	Harness Ign.
41	17720408	Screw 1/4-20 x 1/2
42	131563	Cover, Terminal Red
43	145673	Solenoid
45	122822X	Ammeter
46	110940X	Meter, Hour
47	17011008	Screw
49	153249	Washer, Pinned Delta
50	146283	Switch, PTO
51	140405	Ring Retainer PTO
53	71031008	Screw Hex Washer Hd #10-32 x 1
54	73951000	Nut Keps #10-32

NOTE: All component dimensions given in U.S. Inches
1 inch = 25.4 mm

REPAIR PARTS

TRACTOR -- MODEL NUMBER 917.251561

CHASSIS AND ENCLOSURES

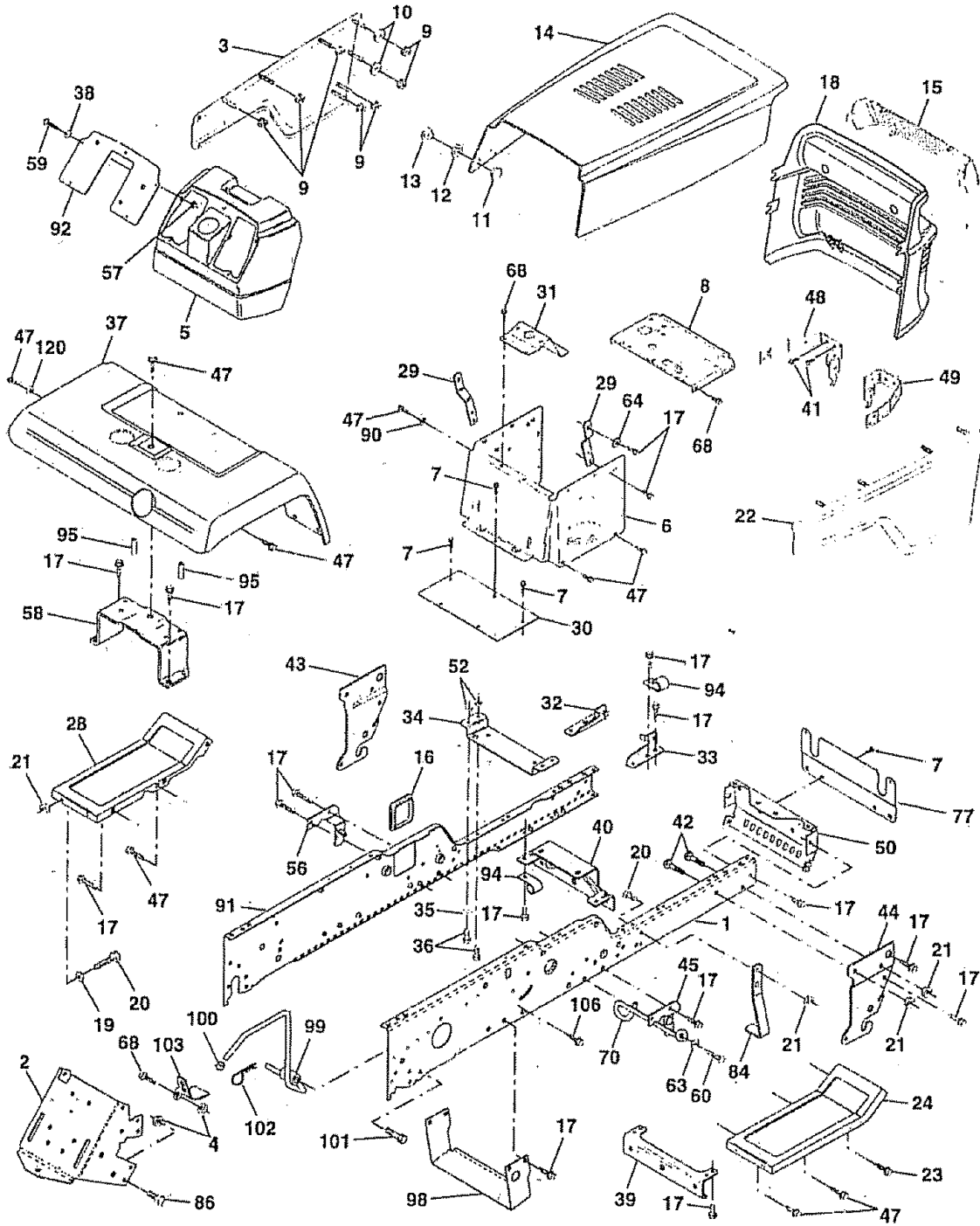

REPAIR PARTS

TRACTOR - - MODEL NUMBER 917.251561

CHASSIS AND ENCLOSURES

KEY NO.	PART NO.	DESCRIPTION	KEY NO.	PART NO.	DESCRIPTION
1	150253	Rail, Frame RH	42	72140608	Bolt, Carriage 3/8-16 x 1
2	140506	Drawbar, Gt	43	136939	Bracket, Spnsn Front Lh
3	136671X558	Panel Asm., Side LH	44	136940	Bracket, Spnsn Front Rh
4	73800700	Nut, Lock Hex 7/16 Unc	45	138460	Bracket Asm., Susp Chassis Rh
5	145203	Dash, Plastic Black	47	17490608	Screw Thdrol 3/8-16 x 1/2
6	150273	Dash Asm., Lower	48	142133	Bracket Asm., Pivot Hood Lh
7	17720408	Screw, Thd Cut 1/4-20 x 1/2	49	142134	Bracket Asm., Pivot Hood Rh
8	145166	Support, Battery	50	152728	Bracket, Chassis Front
9	108067X	Nut, Pal	52	STD541431	Nut, Crownlock 5/16-18
10	19092016	Washer 9/32 x 1-1/4 x 16 Ga.	56	138461	Bracket Asm., Susp Chassis Lh
11	137270	Rivet, Ratchet Male	57	73640400	Nut, Keps Hex 1/4-20
12	137269	Washer, Nylon	58	137113	Bracket Asm., Fender
13	137271	Rivet, Ratchet Female	59	74180412	Screw, Mach Cr 1/4-20 x 3/4
14	136673X558	Hood Asm., Pnt	60	17490620	Screw Thdrol 3/8-16 x 1-1/4
15	136374	Lens, Bar Clear	63	19131614	Washer 13/32 x 1 x 14 Ga.
16	121794X	Cover, Access	64	144283	Washer, Serrated Disc 13/32 x 1
17	17490612	Screw, Thdrol 3/8-16 x 3/4	68	17490508	Screw, Thd 5/16-18 x 1/2
18	136373X428	Grille	70	137159	Guide, Belt Mid Span
19	19131312	Washer 13/32 x 13/16 x 12 Ga.	77	137308	Shield, Front
20	STD523710	Bolt, Fin Hex 3/8-16 x 1	84	142992	Stop, Over Center Mower
21	STD541437	Nut, Crownlock 3/8-16 Unc	86	74760716	Bolt, Fin Hex 7/16-14 Unc x 1
22	136670X558	Panel Asm., Side RH	90	STD551237	Washer, Lock External Tooth 3/8
23	17490616	Screw Thdrol 3/8-16 x 1 Ty-Tt	91	150851	Rail, Frame Lh
24	145243X558	Footrest, RH	92	146967X011	Plate, Silkscreen Dash
28	145244X558	Footrest, LH	94	100207K	Clip, Fuel Line
29	145349	Bracket, Support Dash	95	105531X	Push Nut, Nylon
30	145052	Saddle, Hydro 1995	98	140503	Bracket Skid Chassis
31	145183	Brace, Support Steering	99	140871	Rod By Pass
32	141315	Bracket Asm., Frame Pivot Lh	100	124236X	Cap By Pass Rod
33	141314	Bracket Asm., Frame Pivot Rh	101	17490628	Screw Thdrol 3/8-16 x 1-3/4
34	142131	Bracket, Engine Support Rear	102	4497H	Retainer, Spring
35	19111116	Washer 11/32 x 11/16 x 16 Ga.	103	142273	Lock, By Pass
36	74780512	Bolt, Fin Hex 5/16-18 x 3/4	106	138776	Bolt 5/16-18 Type TT
37	140002X558	Fender, Pnt	120	19131616	Washer 13/32 x 1 x 16 Ga.
38	19091216	Washer 9/32 x 3/4 x 16 Ga.	--	8022J	Plug, Hole
39	136961	Bracket, Axle Front			
40	142132	Bracket, Support Axle/Engine			
41	17580408	Screw Tap Tite 1/4-20 x 1/2			

NOTE: All component dimensions given in U.S. inches
1 inch = 25.4 mm

REPAIR PARTS

TRACTOR -- MODEL NUMBER 917.251561

GROUND DRIVE

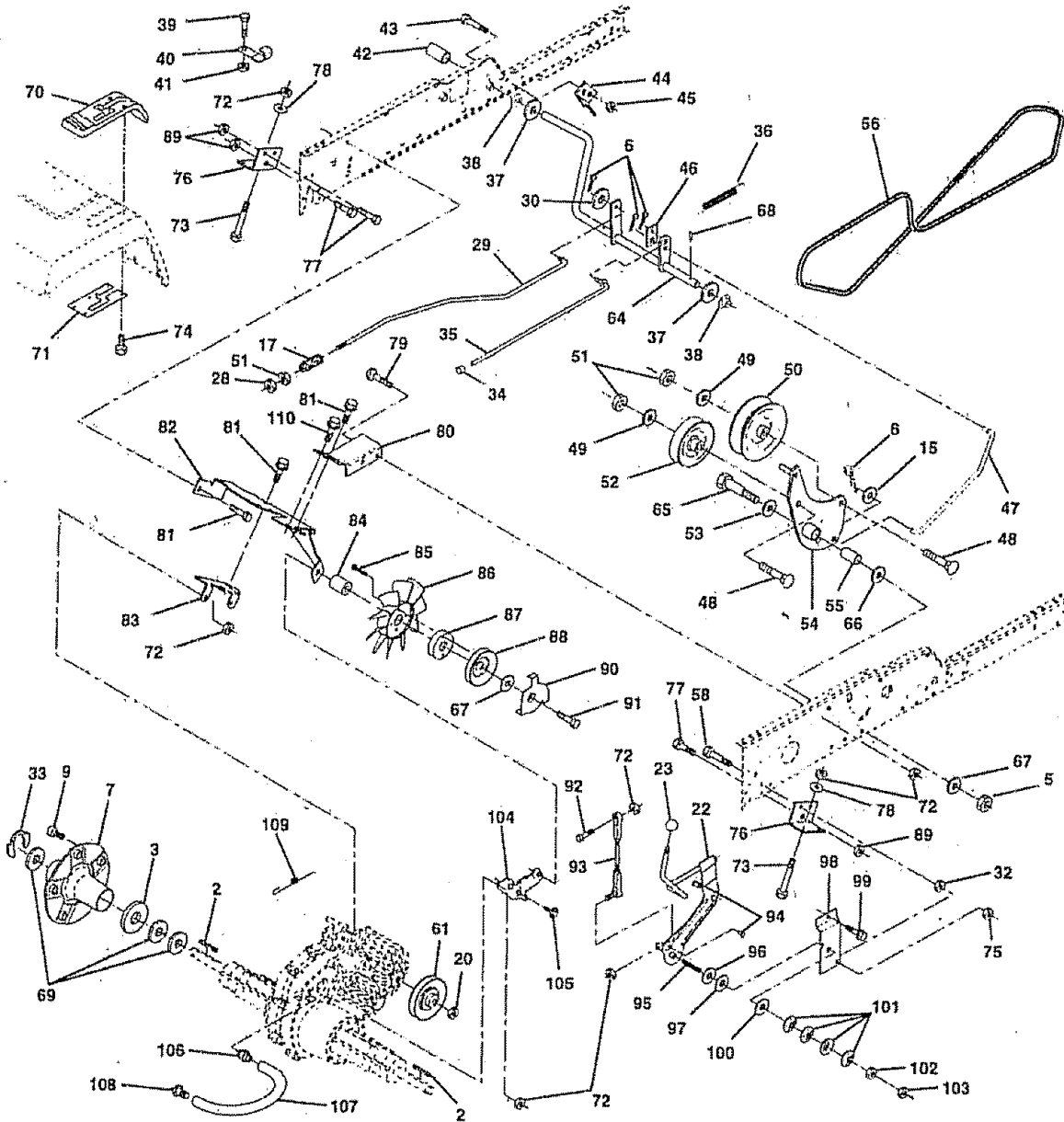

REPAIR PARTS

TRACTOR -- MODEL NUMBER 917.251561

GROUND DRIVE

KEY NO.	PART NO.	DESCRIPTION	KEY NO.	PART NO.	DESCRIPTION
2	7070E	Key 1/4 x 2.5	69	123800X	Washer
3	7563R	Washer Thrust Axle Harden	70	151146	Console Hydro Fender
5	STD541437	Nut Crownlock 3/8-16	71	151179	Plate Console Shift
6	STD561210	Pin Cotter 1/8 x 3/4	72	STD541431	Locknut Hex W/Washer Insert
7	140507	Wheel Hub Asm.	73	74780548	Bolt Fin Hex 5/16-18 x 3
9	140980	Bolt Hub	74	142432	Screw Hex Wsh. Hi-Lo 1/4-1/2
15	STD551037	Washer 13/32 x 13/16 x 16 Ga	75	73800700	Nut Lock Hex 7/16
17	140921	Spring Rod Brake	76	140481	Bracket Transaxle
20	73940800	Nut Hex Jam Toplock 1/2-20	77	74760716	Bolt Fin Hex 7/16-14 x 1
22	140498	Shift Arm Asm	78	19111212	Washer 1 1/32 x 3/4 x 12 Ga
23	130564	Knob	79	72110505	Bolt Carriage 5/16-18 x 5/8
28	STD541237	Nut	80	140484	Bracket Torque RH
29	140494	Brake Rod	81	17490612	Screw Thdrol 3/8-16 x 3/4
30	19131616	Washer 13/32 x 1 x 16 Ga.	82	150586	Bracket Mount Torque/Fan
32	73220700	Nut Hex 7/16-14	83	140479	Strap Torque Mid
33	12000053	Ring E	84	140490	Spacer
34	124236X	Cap Parking Brake	85	17541020	Screw #10-24 x 1-1/4
35	137648	Rod Parking Brake	86	140462	Fan 7" Hydro
36	149412	Spring Drive Ground	87	140491	Adapter Fan
37	121749X	Washer 25/32 x 1-1/4 x 16 Gauge	88	140492	Pulley Idler
38	150035	Nyliner	89	73680700	Nut Crownlock 7/16-14 UNC
39	74321016	Screw Fin #10-24 x 1	90	140489	Keeper Bell
40	5304J	Actuator Interlock Switch	91	17490644	Screw Thdrol 3/8-16 x 2-3/4
41	73631000	Nut Lock #10-24	92	74760520	Bolt Fin Hex 5/16-18 x 1.25
42	8883R	Cover Pedal	93	140502	Link Shift Asm
43	74760412	Bolt Hex Head 1/4-20 x 3/4	94	133835	Fastner Christmas Tree
44	104601X	Bracket Interlock	95	23200528	Screw Set 5/16-18 x 1.5
45	73800400	Nut Lock W/Insert 1/4-20	96	141103	Washer Nickel Plated
46	145170	Retainer Spring	97	126874X	Bearing Trust
47	138228	Clutch Rod	98	141004	Bracket Shift
48	72110614	Bolt Carriage 3/8-16 x 1-3/4 Gr 5	99	17490624	Screw Thdrol 3/8-16 x 1-1/2
49	19131413	Washer 13/32 x 7/8 x 13 Ga	100	126881X	Washer Compression
50	131494	Pulley Idler Flat	101	59285	Washer Belleville
51	STD541437	Nut Crownlock 3/8-16 UNC	102	73560500	Nut Hex Nylok
52	139123	Pulley Idler Grooved	103	73350500	Nut Hex Jam 5/16-18
53	207J	Washer Hardened	104	140480	Bracket Idler
54	138390	Clutch Arm Asm	105	17580408	Screw Tap 1/4-20 x 1/2
55	105706X	Bearing, Idler	106	142576	Fitting Vent Hose
56	140218	V-Belt	107	142577	Vent Hose
58	74760724	Bolt Fin Hex 7/16-14 x 1-1/2	108	142578	Cap Vent Hose
61	140488	Pulley Input	109	140929	Spring Return Brake
64	137649	Shaft Asm Brake Parking Clutch	110	88652	Bolt
65	67609	Bolt Shoulder	--	150073	Transaxle Hydro
66	140296	Washer Hardened			
67	19131312	Washer 13/32 x 13/16 x 12 Ga			
68	5142H	Pin Roll			

NOTE: All component dimensions given in U.S. Inches
1 inch = 25.4 mm



REPAIR PARTS

TRACTOR -- MODEL NUMBER 917.251561

STEERING ASSEMBLY

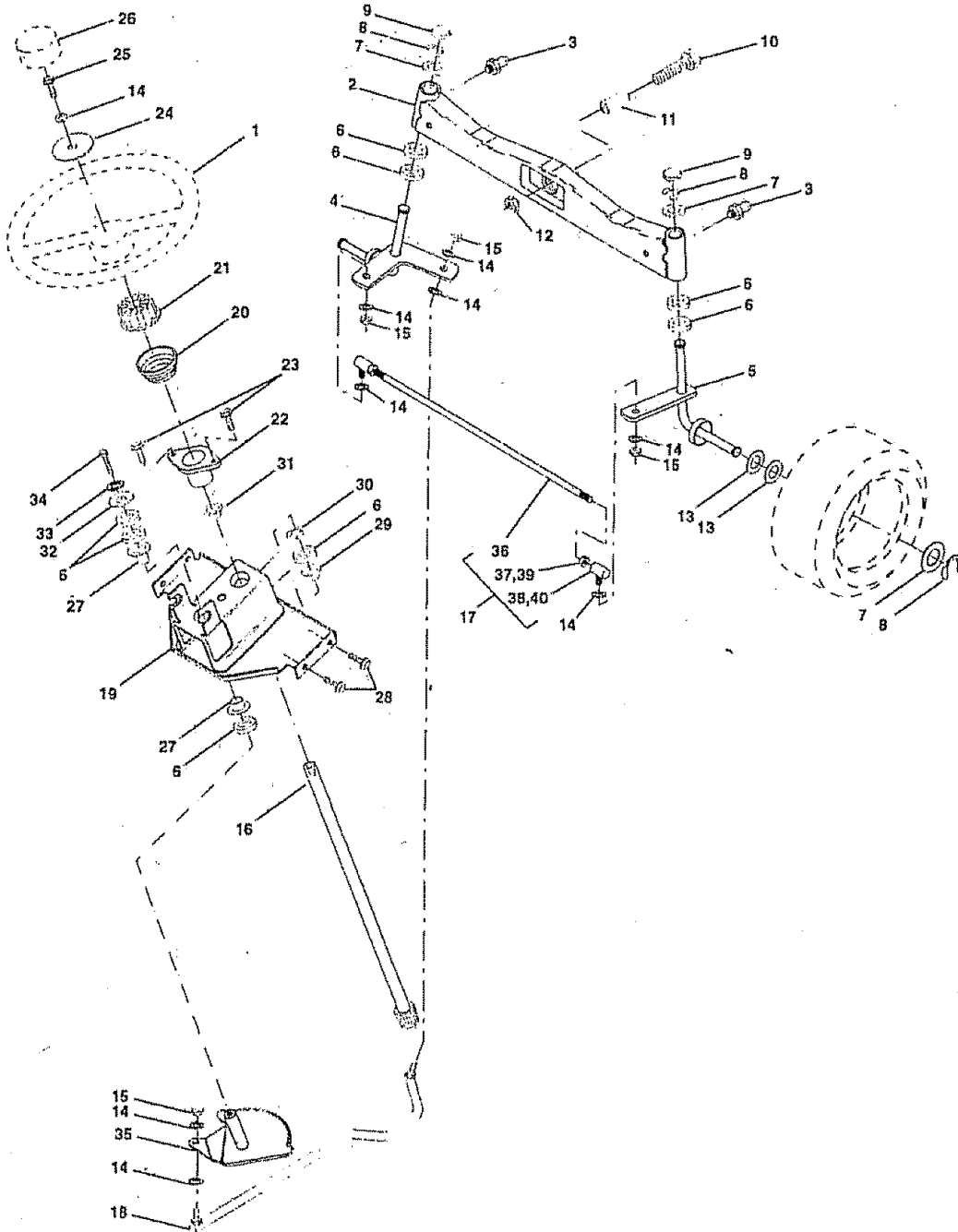

REPAIR PARTS

TRACTOR - - MODEL NUMBER 917.251561

STEERING ASSEMBLY

KEY NO.	PART NO.	DESCRIPTION
1	121472X	Wheel, Steering
2	137094	Axle Asm., Front
3	6855M	Fitting, Grease
4	136960	Spindle Asm., LH
5	136959	Spindle Asm., RH
6	6266H	Bearing, Race Thrust Harden
7	121748X	Washer 25/32 x 1-5/8 x 16 Ga.
8	12000029	Ring, Klip #T5304-75
9	121232X	Cap, Spindle
10	74781044	Bolt, Fin Hex 5/8-11 x 2-3/4
11	136518	Spacer, Brg Axle Front
12	73901000	Nut, Lock Flange 5/8-11 Unc
13	121749X	Washer 25/32 x 1-1/4 x 16 Ga.
14	STD551137	Washer, Lock Hvy Hlcl Spr 3/8
15	73610600	Nut, Fin Hex 3/8-24 Unf
16	145103	Shaft Asm., Steering
17	137347	Rod Asm., Tie Bail J Ball Vgt (Inc. Key No. 36-40)
18	137155	Draglink, Bail Joint Solid Vgt
19	146611	Support Asm., Steering Vgt
20	145182	Column, Steering
21	100711L	Adapter, Wheel Steering
22	1554J	Bushing, Strg. Blk
23	152927	Screw, TT #10-32.5.3/8 Flange
24	19133808	Washer 13/32 x 2-3/8 x 8 Ga.
25	STD523710	Bolt, Fin Hex 3/8-16 x 1 Gr. 5
26	126805X	Cap, Wheel Steering
27	3366R	Bearing, Col. Strg.
28	17490612	Screw, Thrdrol 3/8-16 x 3/4
29	104239X	Bearing, Flange
30	12000034	Ring, Klip Truarc #5304-75
31	138136	Bushing, Nylon Snap
32	19111610	Washer 11/32 x 1 x 10 Ga.
33	STD551131	Washer, Lock Hvy Hlcl Spr 5/16
34	STD523107	Bolt, Hex Hd 5/16-18 x 3/4
35	138059	Gear, Sector Steering
36	137156	Tie Rod
37	73360600	Jam Nut RH Thread
38	109850X	Joint Asm. Ball RH Thread
39	73700600	Jam Nut LH Thread
40	109851X	Joint Asm. Ball LH Thread

NOTE: All component dimensions given in U.S. inches
1 Inch = 25.4 mm

REPAIR PARTS

TRACTOR - - MODEL NUMBER 917.251561

ENGINE

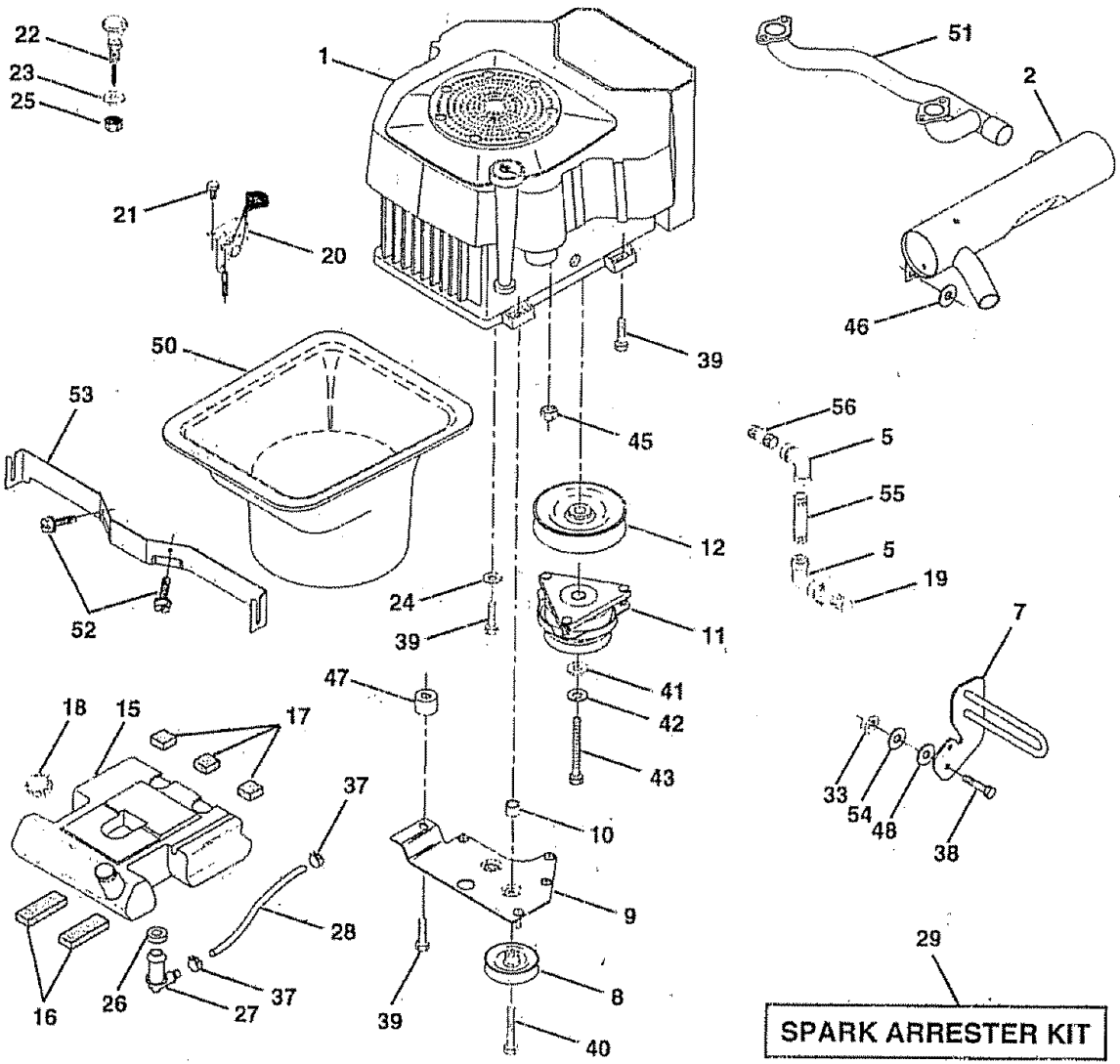

REPAIR PARTS

TRACTOR -- MODEL NUMBER 917.251561

ENGINE

KEY NO.	PART NO.	DESCRIPTION
1	140847	Engine Kohler 22.5 HP Model CV22-PS67515
2	144636	Muffler Cylinder VGT (Inc. Key No. 34)
5	13200300	Elbow STD 90 Degree 3/8 - 18 NPT
7	151396	Muffler Assembly Guard
8	121361X	Pulley V-Idler
9	145109	Stop Keeper Asm VGT
10	105432X	Bushing
11	140923	Clutch Electric
12	143996	Pulley Engine
15	151346	Tank Fuel Rear 3.50 YT/GT
16	109227X	Pad Spacer
17	106082X	Pad Spacer
18	151296	Cap Asm Fuel W/Gauge Vented
19	13290300	Plug Oil Drain (Order From Engine Manufacturer)
20	132755	Control Throttle
21	17720410	Screw Hex Thd Cut 1/4 - 20 X 5/8
22	132779	Control Choke
23	19132616	Washer 13/32 X 1 - 5/8 X 16 Ga
24	STD551237	Lockwasher Ext Tooth 3/8
25	73920600	Nut Keps 3/8 - 24 UNF
26	3645J	Bushing
27	139277	Stem Tank Fuel
28	7834R	Fuel Line
29	132920	Spark Arrester Kit
33	STD541437	Nut Lock Hex w/Ins 3/8-16 Unc
37	123487X	Clamp Hose
38	74780624	Bolt Fin Hex 3/8-16 Unc x 1-1/2
39	17490636	Screw Tt 3/8-16 x 2-1/4 Unc
40	17490664	Screw Tt 3/8-16 x 4 Unc
41	126197X	Washer 1-1/2 OD X 15/32 ID X .250
42	10040700	Washer Lock 7/16
43	150280	Bolt Hex 7/16-20 X 4-1/4 Ga 5
45	128861	Nut Flange 1/4-20 Starter Nut
46	19131616	Washer 13/32 x 1 x 16 Ga.
47	142040	Spacer Engine CV22 Round Pm
48	19132007	Washer 13/32 x 1-1/4 x 7 Ga.
50	143020	Duct Air VGT Sears Kohler CV22
51	140787	Pipe Crossover CV22
52	17580408	Screw Tap Tite 1/4-20 x 1/2
53	143528	Bracket Duct Air Rear Support
54	19131414	Washer Flat 13/32 x 7/8 x 14 Ga.
55	13090336	Nipple Pipe 3/8 Npt x 4-1/2.
56	13090308	Nipple Pipe 3/8 Npt x 1.00
61	2751R	Clp Line Fuel

NOTE: All component dimensions given in U.S. inches
1 inch = 25.4 mm

REPAIR PARTS

TRACTOR -- MODEL NUMBER 917.251561

SEAT ASSEMBLY

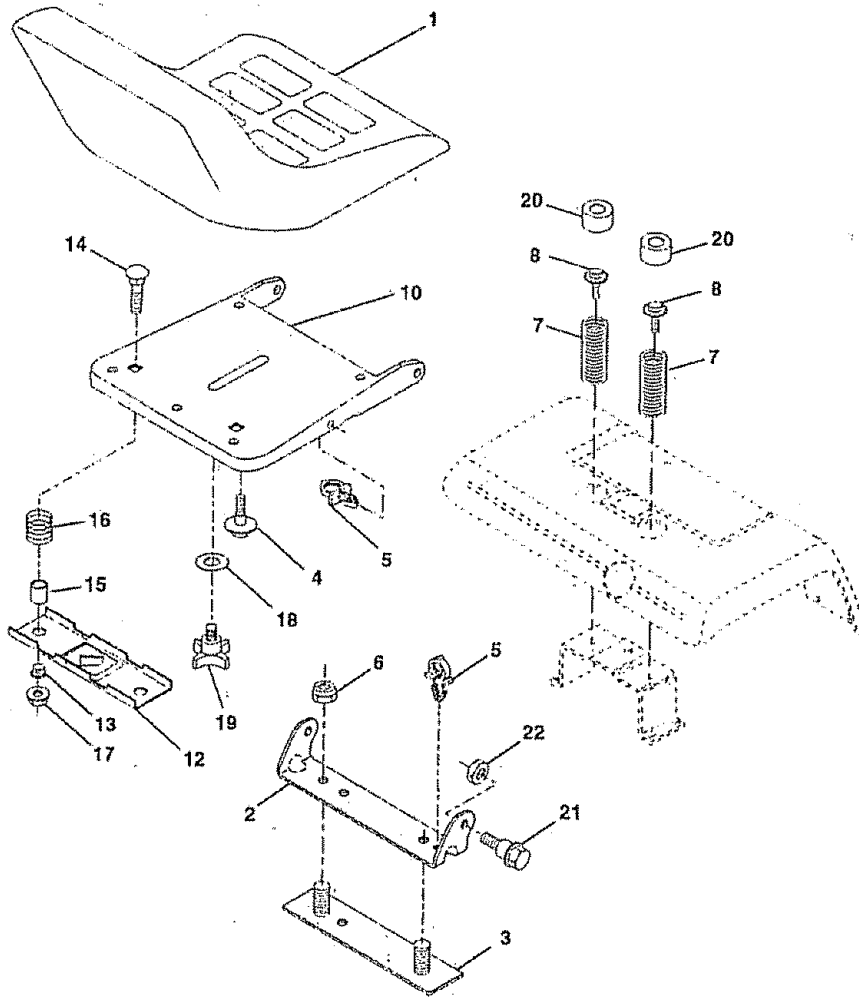

KEY PART
NO. NO.

KEY NO.	PART NO.	DESCRIPTION
1	140124	Seat
2	140551	Bracket, Pivot Seat
3	140675	Strap, Fender
4	127018X	Bolt, Shoulder 5/16-18 X .62
5	145006	Clip, Push In Hinged
6	STD541437	Nut, Crownlock 3/8-16 Unc
7	124181X	Spring, Seat Cprsn
8	150176	Bolt 5/16-18 UNC x 3/4 w/Sem
10	140552	Pan, Seat
12	121246X	Bracket, Mounting Switch
13	121248X	Bushing, Snap

KEY PART
NO. NO.

KEY NO.	PART NO.	DESCRIPTION
14	72050411	Bolt, Carriage 1/4-20 X 1-3/8
15	121249X	Spacer, Split
16	123740X	Spring, Cprsn
17	123976X	Nut, Lock 1/4 Lge Fig Gr. 5
18	19171912	Washer 17/32 X 1-3/16 X 12 Ga.
19	120068X	Knob, Seat 1/2-13 Unc
20	124238X	Cap, Spring Seat
21	153236	Bolt, Shoulder 5/16-18 Unc
22	STD541431	Nut, Crownlock 5/16-18 Unc

NOTE: All component dimensions given in U.S. inches
1 inch = 25.4 mm



REPAIR PARTS

TRACTOR - - MODEL NUMBER 917.251561

DECALS

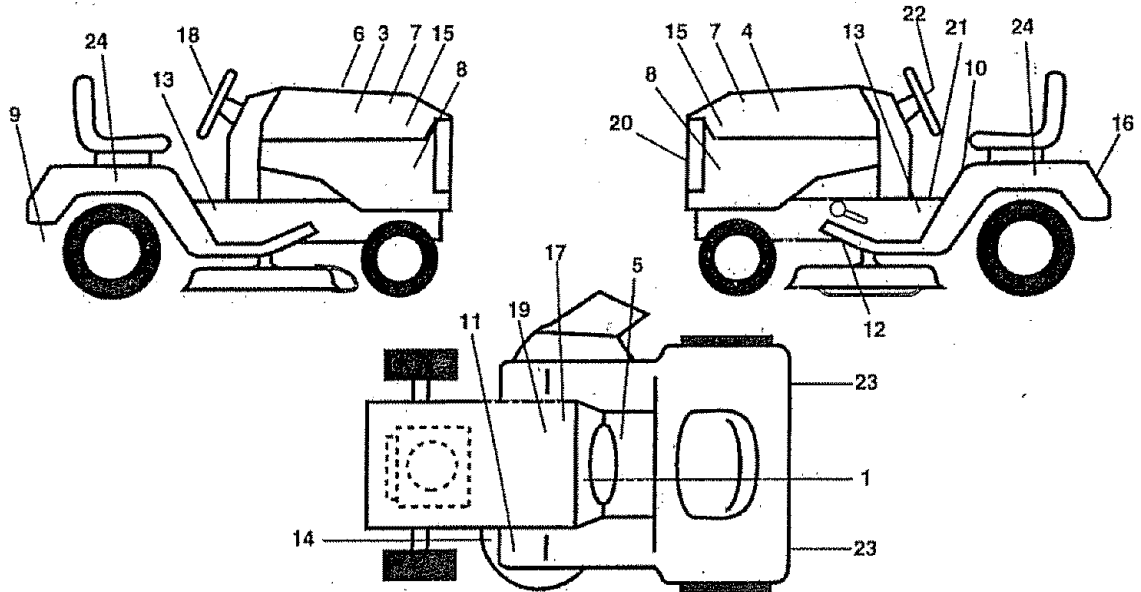

KEY NO.	PART NO.	DESCRIPTION
1	138955	Decal, Operating Instruction
3	146705	Decal, Hood, Craftsman, RH
4	146706	Decal, Hood, Craftsman, LH
5	140837	Decal, Brake Parking Saddle
6	133644	Decal, Maintenance
7	138048	Decal, Side Panel
8	151568	Decal, Ins. Hood
9	142342	Decal, Control Movement
10	137537	Decal, Caution
11	4900J	Decal, Clutch/Brake
12	139346	Decal, V-Belt Drive Schematic
13	146711	Decal, Chassis, Hydro 50"
14	146790	Decal, V-Belt Schematic
15	142241	Decal, Panel Side

KEY NO.	PART NO.	DESCRIPTION
16	146709	Decal, Fender
17	149516	Decal, Btry Dngr/Psn Eng. Acme
18	146710	Decal, Insert Strg
19	138047	Decal, Battery
20	151448	Decal, Grille
21	142336	Decal, SDL Cold Start
22	150333	Decal, Cap Cnsmr Help Line Srs
23	106202X	Reflector, Taillight
24	149918	Decal, Fender Hyd/Auto Gold Srs
--	138311	Decal, Handle LFT Hleght Adj. (Lift Handle)
--	145245	Pad Footrest
--	145247	Fastener Pop-In Footrest
--	154452	Manual, Owner's (Eng)
--	154453	Manual, Owner's (Span)

WHEELS & TIRES

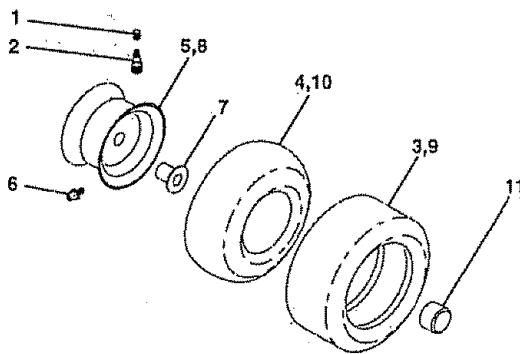

KEY NO.	PART NO.	DESCRIPTION
1	59192	Cap, Valve, Tire
2	65139	Stem, Valve
3	148741	Tire, Front
4	8134H	Tube, Front (Service Item Only)
5	148736X427	Rim Assembly, Front
6	6856M	Fitting, Grease
7	9040H	Bearing, Flange (Front Wheel Only)
8	148738X427	Rim Assembly, Rear
9	151607	Tire, Rear
10	7154J	Tube, Rear
11	104757X	Cap Hub Axle BLK 1.50 x 1.00
--	144334	Sealant, Tire (10 oz. tube)

NOTE: All component dimensions given in U.S. inches
1 inch = 25.4 mm

REPAIR PARTS

TRACTOR - - MODEL NUMBER 917.251561

LIFT ASSEMBLY

KEY NO.	PART NO.	DESCRIPTION
1	121006X	Rod Asm., Lever
2	145542	Shaft Asm., Lift Vgt
3	121002X	Lever Asm., Lift Rh
4	1200022	E-Ring Truarc #5133-67
5	19292016	Washer 29/32 x 1-1/4 x 16 Ga.
6	74780624	Bolt, Fin Hex 3/8-16 x 1-1/2
7	125631X	Grip, Handle Fluted
8	122365X	Button, Plunger
9	122364X	Plunger, Lever Lift
10	2876H	Spring 2-1/8"
11	146704	Link Lift
12	3146R	Retainer, Spring
13	139868	Arm, Suspension Vgt
14	140302	Bearing, Pvt. Lift Spherical
15	STD541437	Nut, Crownlock 3/8-16 Unc
16	674A247	Spring Asm., Assist Lift
17	STD541237	Nut, Hex Jam 3/8-16 Unc
18	143363	Bracket, Spring Assist
19	STD551037	Washer 13/32 x 13/16 x 16 Ga.
20	5326J	Bolt, Adjust Spring Assist
21	STD523710	Bolt, Fin Hex 3/8-16 x 1
22	127218	Link, Front
23	4939M	Retainer, Spring
24	73350800	Nut, Jam Hex 1/2-13 Unc
25	130171	Trunnion
26	73800800	Nut, Lock W/Wsh 1/2-13 Unc
29	150233	Trunnion, Infln. Height
30	110807X	Nut, Special
31	19131016	Washer 13/32 x 5/8 x 16 Ga.
32	137150	Spring, Compression Inf Hgt
33	76020308	Pin, Cotter 3/32 x 1/2
34	137167	Rod, Adj Lift
35	138057	Knob, Inf 3/8-16 Unc
36	17490612	Screw, Thdrol 3/8-16 x 3/4
37	120529X	Washer, Nylon
38	123933X505	Pointer, Pnt Height Indicator
39	123935X	Plug, Hole
40	17490512	Screw Thdrol 5/16-18 x 3/4
41	73540600	Nut, Crownlock 3/8-24
42	19112410	Washer 11/32 x 1-1/2 x 10 Ga.
43	123934X	Scale, Indicator Height
70	154212	Nut, Hex, Flange, Lock

NOTE: All component dimensions given in U.S. inches
1 inch = 25.4 mm

REPAIR PARTS

TRACTOR -- MODEL NUMBER 917.251561

MOWER DECK

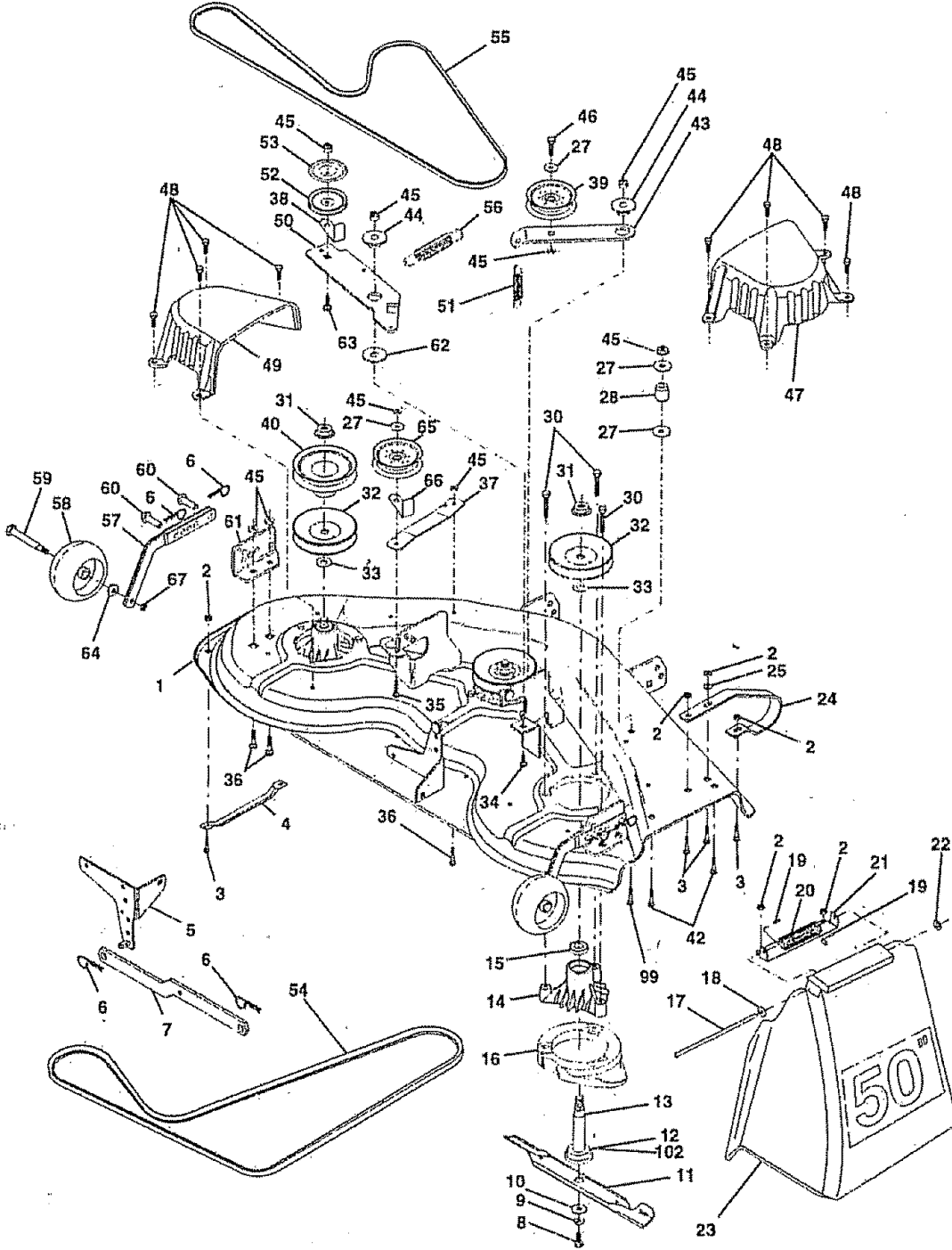

REPAIR PARTS

TRACTOR -- MODEL NUMBER 917.251561

MOWER DECK

KEY NO.	PART NO.	DESCRIPTION	KEY NO.	PART NO.	DESCRIPTION
1	136457	Deck Asm., Mower 50" Vented	538	137554	Keeper, Belt Idler
2	STD541431	Nut, Crownlock 5/16-18	39	131494	Pulley, Idler Flat
3	72110506	Bolt, Carriage 5/16-18 x 3/4	40	136572	Pulley, Driven
4	7631J	Runner, Mower LH	42	72140506	Bolt, Carriage 5/16-18 Unc x 3/4
5	136457	Bracket Asm., Sway Bar	43	136460	Arm, Idler Secondary
6	4939M	Retainer, Spring	44	122052X	Spacer, Retainer
7	130832	Arm Suspension, Rear	45	STD541437	Nut, Crownlock 3/8-16 Unc
8	850857	Bolt 3/8-24 x 1.25 Gr. 8 Patched	46	74760628	Bolt, Fin Hex 3/8-16 Unc x 1-3/4
9	STD551137	Washer, Lock Hvy 3/8 Unplated	47	137200	Cover, Mandrel RH
10	140296	Washer, Hard Blade Mower Vented	48	137729	Screw, Thd Roll 1/4-20 x 5/8
11	137380	Blade (3 Required)	49	136574	Cover, Mandrel LH
12	129895	Bearing, Ball #6204 (Mandrel)	50	137272	Arm, Idler Primary
13	137553	Shaft Asm., W/Lower Brg (Includes Key No. 12)	51	137273	Spring, Secondary
14	137152	Housing, Mandrel 44" Vent	52	139245	Pulley, Idler V Groove
15	110485X	Bearing, Ball Mandrel	53	137789	Shield, Idler
16	140329	Stripper, Mower Round	54	139573	V-Belt, Mower Primary
17	106735X	Rod, Hinge	55	144959	V-Belt, Mower Secondary
18	19111016	Washer 11/32 x 5/8 x 16 Ga.	56	138687	Spring, Primary
19	105304X	Cap, Sleeve	57	136577	Bar Asm., Wheel Gauge
20	123713X	Spring, Torsion Deflector	58	133957	Wheel, Gauge
21	137607	Bracket, Deflector	59	137644	Bolt, Shoulder
22	110452X	Nut, Push	60	139031	Pin, Clevis
23	110509X	Shield, Deflector Mower	61	136573	Bracket, Wheel Gauge
24	136320	Runner, RH	62	133943	Washer Hardened
25	19111216	Washer 11/32 x 3/4 x 16 Ga.	63	72110612	Bolt Carriage 3/8-16 x 1-1/2
27	19131316	Washer 13/32 x 13/16 x 16 Ga.	64	19121414	Washer 3/8 x 3/4 x 14Ga
28	132823	Spacer, Spring Stop Idler	65	151831	Pulley, Flat, Idler5
30	138776	Screw Thdrol Hex Head	66	139622	Keeper, Belt, Idler
31	137266	Nut, Flg Top Lock Cntr 9/16	67	73930600	Nut, Centerlock 3/8-16
32	153535	Pulley, Mandrel5	99	72110614	Bolt, Carriage 3/8-16 x 1-3/4 Gr. 5
33	129963	Washer, Spacer Mower Vented	102	153390	Felt Washer
34	72140610	Bolt, Carriage 3/8-16 x 1-1/4	--	141051	Mower Service
35	72110616	Bolt, Carriage 3/8-16 x 2	--	143651	Mandrel Asm. (Includes Key Nos. 8-10, 12-15, 31, 33)
36	72110608	Bolt, Carriage 3/8-16 x 1 Gr 5			
37	137166	Stiffener, Arm Idler			

NOTE: All component dimensions given in U.S. inches
1 inch = 25.4 mm



REPAIR PARTS

TRACTOR -- MODEL NUMBER 917.251561

HYDRO GEAR TRANSAXLE -- MODEL NUMBER 218-3010

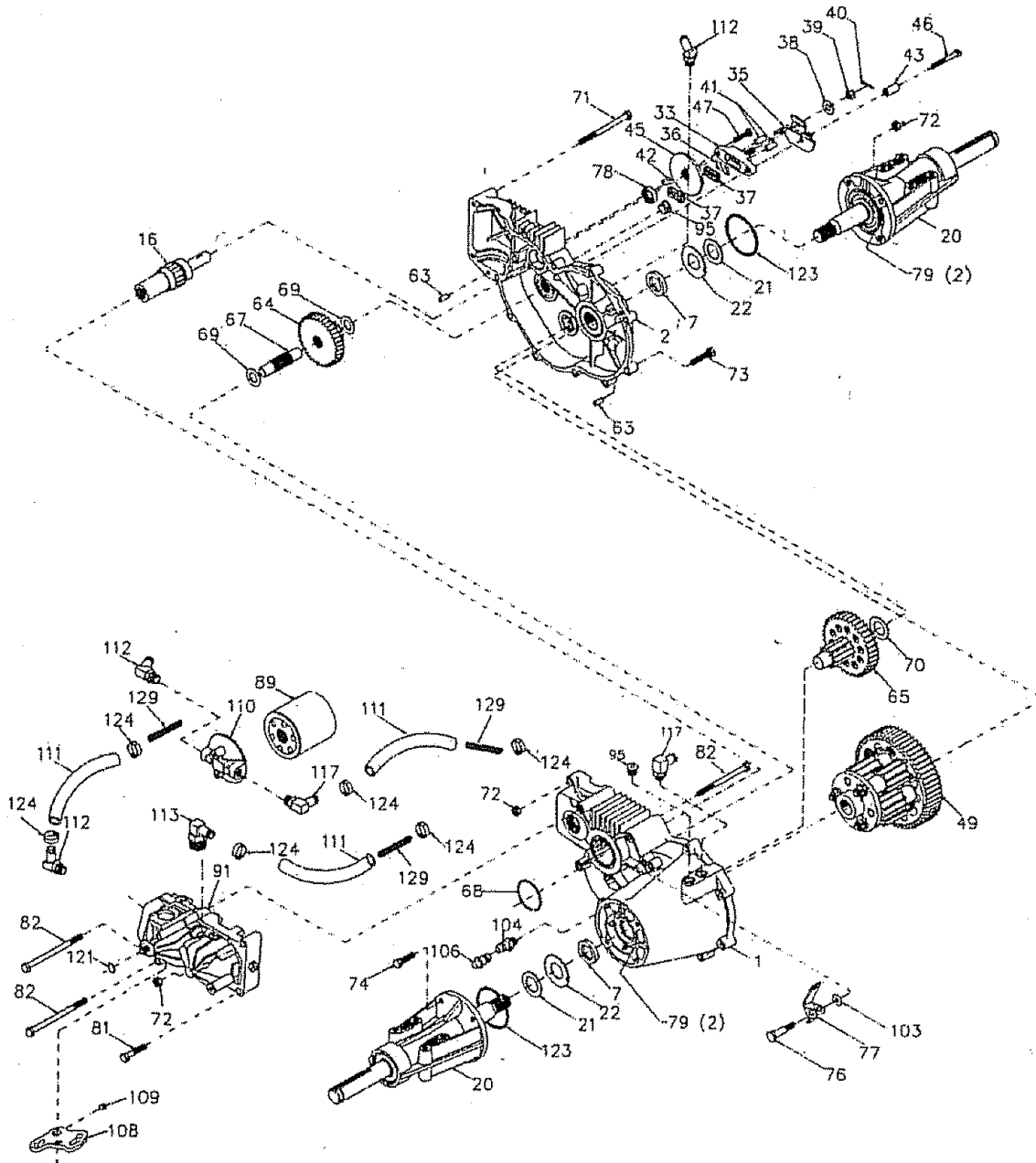

REPAIR PARTS

TRACTOR - - MODEL NUMBER 917.251561

HYDRO GEAR TRANSAXLE - - MODEL NUMBER 218-3010

KEY PART NO. NO.	DESCRIPTION	KEY PART NO. NO.	DESCRIPTION
1 142874	Assembly, Housing, LH	72 153767	Locknut, Hex 5/16-18
2 142875	Assembly, Housing, RH	73 142904	Bolt, Hex 5/16-18 x 1-1/2
7 153765	Oil Seal .984 x 1.5 x .25	74 142905	Hex Cap Screw 5/16-18 x 1
16 142876	Brake Shaft Assembly	76 142907	Shoulder Bolt
20 142877	Axle Mounting Horn Assembly	77 142908	Freewheel Actuating Arm
21 142878	Washer 1.0 x 1.63 x .08	78 142909	Oil Seal .625 x 1.0 x .25
22 142879	Washer 1.0 x 2.06 x .09	79 153768	Grease (10 oz. Tube)
33 142829	Brake Yoke Assembly	81 142910	Bolt, Hex 5/16-18 x 1-3/4
35 142880	Brake Arm	82 142911	Bolt 5/16-18 x 4-1/2
36 142882	Puck Plate	89 142912	Filter, Spin On
37 142883	Brake Puck	91 153769	Pump, BDU-10L-122
38 142884	Washer 7/8 O.D. x 7/16 x .060	95 142914	Plug, Straight Thread
39 142885	Nut, Castle 5/16-24	96 153770	60° 7/18 SAE x 5/16 Fitting
40 142886	Cotter Pin	103 142916	Washer
41 142887	Brake Actuating Pin	104 142917	Vent Cap Assembly
42 142888	Hi Pro Key	106 142918	Fitting O-Ring Assembly
43 142889	Spacer	108 142919	Control Arm
45 142890	Brake Disc	109 142920	Set Screw
46 142891	Bolt 1/4-20 x 1-1/2	110 142921	Filter Head
47 142892	Bolt 1/4-20 x 1	111 150820	Hose 1/2"
49 153766	Differential Assembly	112 150823	Fitting, 1/2" Beaded 90° 7/8 SAE
63 142894	Dowel Pin	113 150821	Fitting, 1/2" Beaded 60° 9/16
64 150818	Reduction Gear, 14 Teeth to 38 Teeth	117 150822	Fitting, 1/2" Beaded 90° 9/16
65 142897	Final Drive Pinion Assembly	123 150824	O Ring
67 142898	Jackshaft	124 150825	Pinch Clamp
68 142899	O-Ring	129 153771	Spring, Long
69 142900	Washer 5/8 X 1-5/32		
70 142901	Washer 7/8 X 1-1/2		
71 142902	Bolt, Hex 5/16-18 x 3.5		

NOTE: All component dimensions given in U.S. inches
1 inch = 25.4 mm



REPAIR PARTS

TRACTOR -- MODEL NUMBER 917.251561

HYDRO GEAR PUMP - MODEL NUMBER BU-10L-122

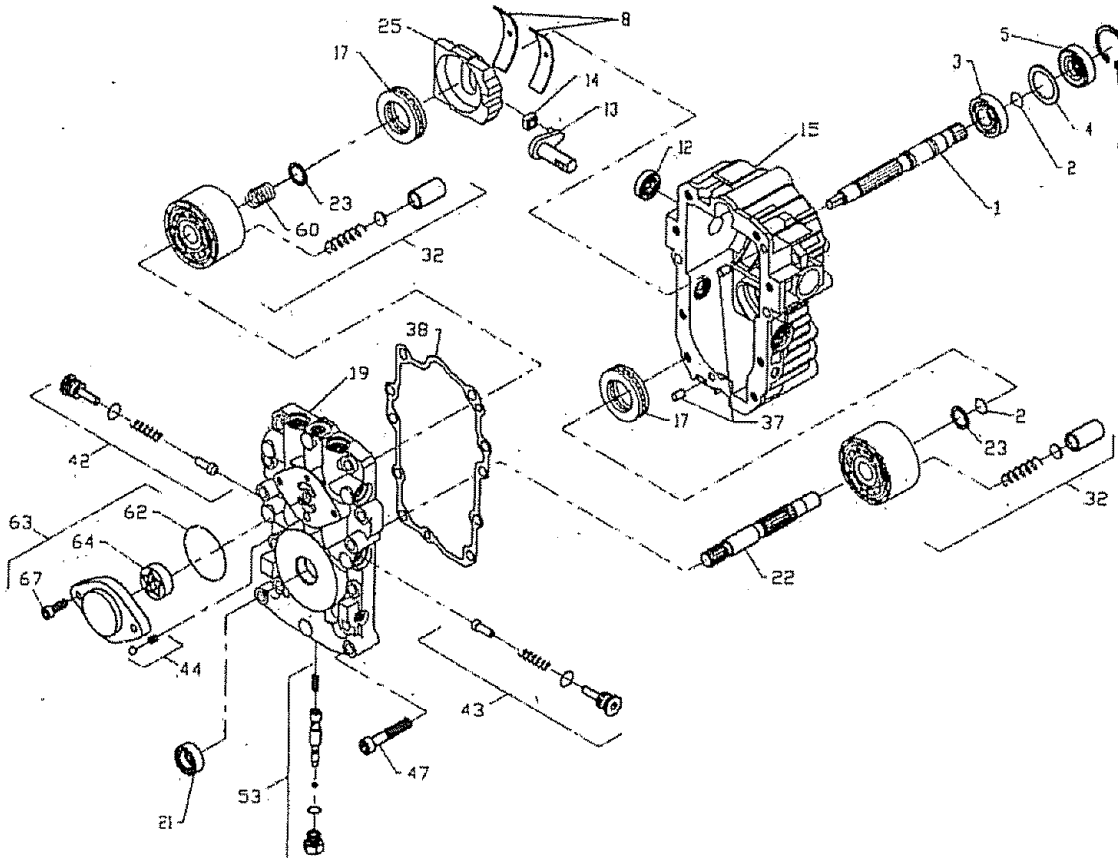

KEY PART NO.	NO.	DESCRIPTION	KEY PART NO.	NO.	DESCRIPTION
1	144569	Shaft, Pump	25	127148X	Swashplate, Variable
2	122716X	Ring, Retaining	32	14293B	Block Assembly
3	122745X	Bearing, Ball	37	122786X	Pin, Stainless, Headless
4	122715X	Spacer	38	122718X	Gasket, Center Section
5	122700X	Seal, Lip	42	144578	Check Valve Kit
6	122699X	Ring, Retaining	43	144578	Check Valve Kit
8	122767X	Bearing, Cradle	44	144579	Charge Relief Kit
12	122717X	Seal, Lip	47	122752X	Screw, Socket Head, Cap.
13	122748X	Arm, Trunnion	53	127153X	Bypass Valve Kit
14	122749X	Guide, Slot	60	142977	Block Spring
15	144571	Housing Kit, Transmission	62	144581	O-Ring
17	122770X	Bearing, Thrust, Ball	63	144582	Charge Pump Kit
19	153801	Center Section Kit	64	144583	Gerotor Assembly
21	122722X	Seal, Lip	67	144584	Screw, Socket Head, Cap.
22	144573	Shaft, Motor	--	153769	Pump Assembly, Complete
23	142978	Washer, Block Thrust			



REPAIR PARTS

TRACTOR - MODEL NUMBER 917.251561

KOHLER ENGINE - MODEL NUMBER CV22S, TYPE NUMBER 67515

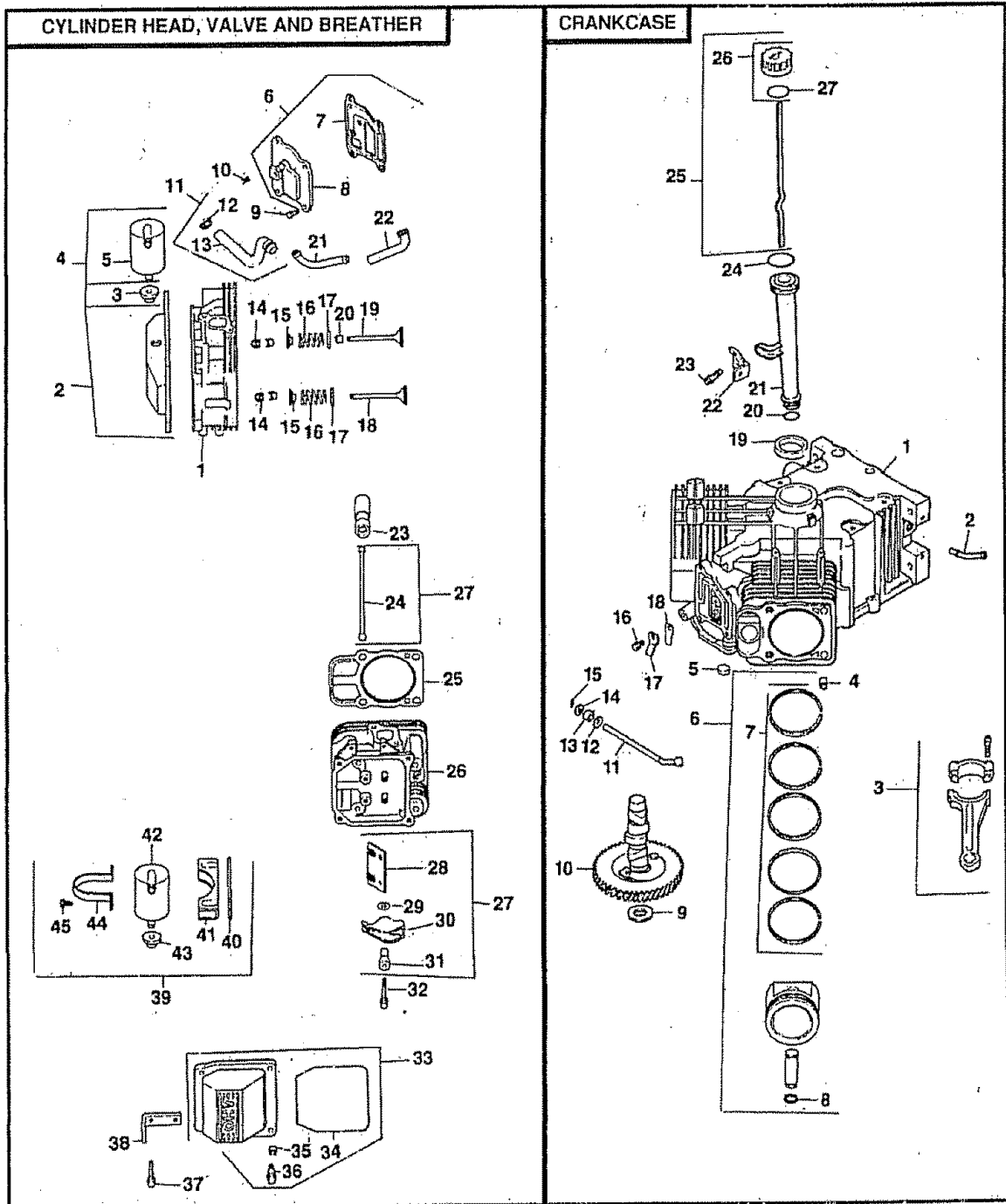

REPAIR PARTS

TRACTOR - - MODEL NUMBER 917.251561

KOHLER ENGINE - MODEL NUMBER CV22S, TYPE NUMBER 67515

CYLINDER HEAD/VALVE/BREATHER

KEY PART NO. NO.	DESCRIPTION
1 24 318 11	Head Assembly, #1 Cylinder
2 24 755 76	Kit, Valve Cover, Breather (Includes Key #3, 34 thru 36)
3 25 313 02	Grommet, Rubber
4 24 755 20	Kit, Breather (Includes Key #3 & 5)
5 24 595 02	Separator, Oil Breather
6 24 033 03	Kit, Breather Cover with Gasket (Includes Key Numbers 7 and 8)
7 24 041 23	Gasket, Breather
8 24 096 15	Cover, Breather
9 SM-0645020	Screw M6 x 1.0 x 20 (4)
10 X-75-23	Plug, Hex Head, Countersunk 1/8 N.P.T.F.
11 24 755 67	Kit, Breather Hose (Includes 12-13)
12 X-426-9	Clamp, Hose (2)
13 24 326 08	Hose, Breather
14 12 755 03	Kit, Retainer (4)
15 12 173 01	Cap, Valve Spring (4)
16 24 089 02	Spring, Valve (4)
17 235011	Retainer, Spring (4)
18 24 016 01	Valve, Exhaust, Standard Size (2)
24 016 02	Valve, Exhaust, .25 Oversize (2)
19 24 017 01	Valve, Intake, Standard Size (2)
24 017 02	Valve, Intake, .25 Oversize (2)
20 24 032 05	Seal, Valve Stem (2)
21 24 294 02	Fitting
22 24 326 05	Hose, Breather
23 12 351 01	Lifter, Valve (4)
24 24 411 04	Rod, Push (4)
25 24 041 08	Gasket, Cylinder Head (2)
26 24 318 12	Head Assembly, #2 Cylinder
27 24 755 61	Kit, Valve Train (Includes Key Numbers 24, 28-31)
28 24 146 09	Plate, Gulde (2)
29 SM-0631005	Washer, Plain (4)
30 24 186 03	Arm, Rocker (4)
31 24 194 02	Pivot, Rocker Arm (4)
32 M-0640034	Screw M6 x 1.0 x 34 (4)
33 24 755 74	Kit, Valve Cover, Plain (Includes Key Numbers 34 thru 36)
34 24 153 11	O-Ring
35 24 112-08	Spacer (4)
36 24 086 32	Screw, Shoulder (4)
37 24 086 16	Screw M10 x 1.5 x 91 (8)
38 24 445 01	Strap, Lifting
39 24 755 57	Kit, Breather Separator (Includes Key Numbers 40 thru 45)
40 24 112 12	Spacer
41 24 126 44	Bracket, Breather Separator
42 24 595 02	Separator, Oil Breather
43 25 313 02	Grommet, Rubber
44 24 445 02	Strap, Breather Separator
45 M-0545016	Screw M5 x 0.8 x 16 (2)

CRANKCASE

KEY PART NO. NO.	DESCRIPTION
1 24 782 05	Cylinder Block (Use Miniblock)
2 24 294 03	Fitting
3 24 067 01	Connecting Rod (Standard) (2)
24 067 02	Connecting Rod (.25) (2)
4 12 380 03	Pin, Dowel Locating (6)
5 52 139 09	Plug, Cup
6 24 874 01	Piston with Ring Set (Standard) (2)
24 874 02	Piston with Ring Set (.25) (2)
24 874 03	Piston with Ring Set (.50) (2)
7 24 108 01	Ring Set (Standard) (2)
24 108 02	Ring Set (.25) (2)
24 108 03	Ring Set (.50) (2)
8 24 018 01	Retainer, Piston Pin (4)
9 12 422 10	Shim, Camshaft, Yellow
12 422 09	Shim, Camshaft, Green (As Required)
12 422 13	Shim, Camshaft, Black (As Required)
12 422 07	Shim, Camshaft, White (As Required)
12 422 08	Shim, Camshaft, Blue (As Required)
12 422 11	Shim, Camshaft, Red (As Required)
12 422 12	Shim, Camshaft, Grey (As Required)
10 24 010 03	Camshaft
11 24 144 01	Shaft, Governor Cross
12 X-25-63	Washer, Plain 1/4
13 12 032 01	Seal, Governor Cross Shaft
14 X-25-102	Washer, Plain 1/4
15 12 380 04	Pin, Hitch
16 M-0545010	Screw, Reed Retainer M5 x 0.8 x 10 (2)
17 24 018 04	Retainer, Reed (2)
18 24 402 05	Reed, Breather (2)
19 24 032 01	Seal, Oil, Front
20 12 153 01	O-Ring, Lower Oil Fill Tube
21 12 123 04	Tube, Oil Fill
22 24 126 19	Bracket, Oil Fill Tube
23 M-0545016	Screw, Oil Fill Tube Bracket M5 x 0.8 x 16
24 12 153 02	O-Ring, upper Oil Fill Tube
25 24 038 04	Dipstick Assembly (Includes 26-27)
26 25 755 13	Kit, Oil Fill Cap (Includes 27)
27 12 153 03	O-Ring, Dipstick

NOTE: All component dimensions given in U.S. Inches
1 inch = 25.4 mm



REPAIR PARTS

TRACTOR -- MODEL NUMBER 917.251561

KOHLER ENGINE - MODEL NUMBER CV22S, TYPE NUMBER 67515

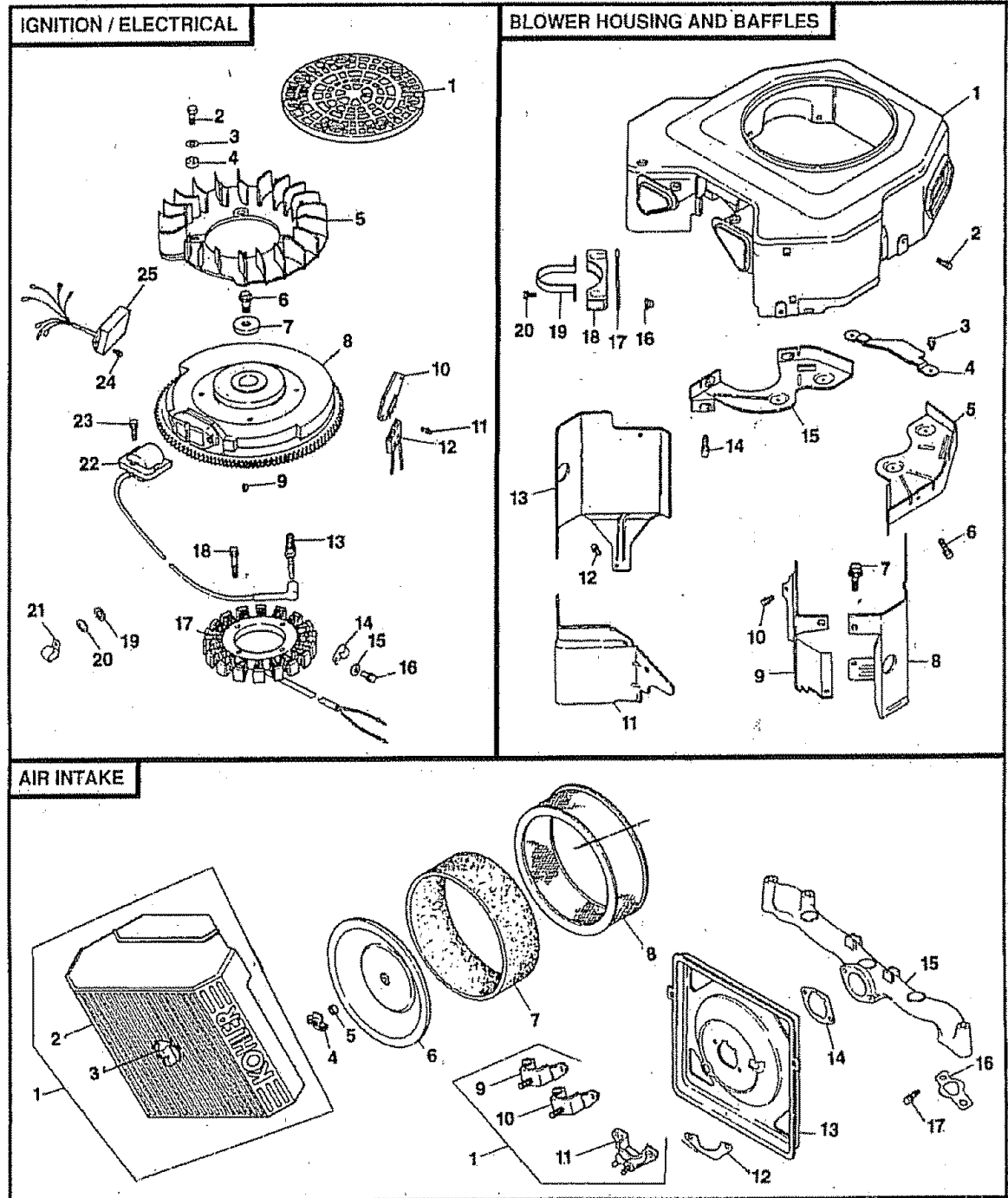

REPAIR PARTS

TRACTOR - - MODEL NUMBER 917.251561

KOHLER ENGINE - MODEL NUMBER CV22S, TYPE NUMBER 67515

IGNITION/ELECTRICAL

KEY PART NO.	NO.	DESCRIPTION
1	24 162 17	Screen, Grass
2	M-0403025	Screw, Grass Screen M4 x 0.7 x 24 (4)
3	X-25-92	Washer, Plain 1/2 (4)
4	24 112 04	Spacer, Fan (4)
5	24 157 03	Fan
6	M-0639016	Screw M6 x 1.0 x 16 (4)
7	12 112 01	Spacer, Fan (4)
8	24 025 05	Flywheel Assembly
9	X-42-15	Key
10	25 403 03	Rectifier-Regulator
11	24 086 18	Screw, Phillips (2)
12	236602	Connector, Rectifier-Regulator, 3 Contact
13	12 132 02	Spark Plug (2)
14	48 154 02	Clip, Cable
15	12 468 03	Washer, Stator Harness Clip
16	12 086 14	Screw, Stator Harness Clip M10 x 1.5 x 46
17	24 085 01	Stator, 15 Amp
18	M-0548025	Screw, Stator Mounting M5 x 0.8 x 25 (2)
19	X-25-63	Washer, Plain 1/4 (2)
20	X-25-92	Washer, Plain 1/2 (2)
21	47 154 01	Clip, Cable
22	24 584 03	Module, Ignition (2)
23	M-0560020	Screw, Module M5 x 0.8 x 20 (4)
24	M-0448010	Screw, Module M4 x 0.7 x 10 (2)
25	24 584 05	Module, Speed Advance
NOT ILLUSTRATED		
--	24 176 27	Harness, Wire
--	24 518 04	Lead, Green (3", 18 Gauge, Insulated Grip Barrel Eyelets)
--	24 113 18	Decal, Grass Screen
--	24 063 27	Baffle, Heat Shield

BLOWER HOUSING & BAFFLES

KEY PART NO.	NO.	DESCRIPTION
1	24 027 20	Housing, Blower
2	M-0549016	Screw M5 x 0.8 x 16 (3)
3	SM-0645016	Screw M6 x 1.0 x 16 (4)
4	24 314 05	Guard, Flywheel
5	24 146 02	Plate, Backing, # 2 Side
6	M-0545020	Screw M5 x 0.8 x 20 (2)
7	M-0551016	Screw M5 x 0.8 x 14
8	24 063 20	Baffle, Cylinder Barrel, # 2 Side
9	24 063 23	Baffle, Valley, # 1 Side
10	M-0545010	Screw M5 x 0.8 x 10 (2)
11	24 063 14	Baffle, Valley, # 2 Side
12	M-0545016	Screw M5 x 0.8 x 16 (2)
13	24 063 19	Baffle, Cylinder Barrel, # 1 Side
14	M-0645016	Screw M6 x 1.0 x 16 (2)
15	24 146 08	Plate, Backing, # 1 Side
16	24 100 01	Nut, Plastic
17	24 112 12	Spacer
18	24 126 44	Bracket, Breather Separator
19	24 445 02	Strap, Breather
20	24 086 27	Screw (2)
NOT ILLUSTRATED		
--	24 100 01	Nut, Plastic (3) (Included with Blower Housing)
--	24 100 02	Nut, Plastic (2) (Included with Blower Housing)
--	25 139 16	Plug, Button 9/16 (Included with Blower Housing)
--	24 113 23	Decal, Horsepower

AIR INTAKE

KEY PART NO.	NO.	DESCRIPTION
1	24 743 05	Kit, Air Cleaner Cover (Includes Key Numbers 2, 3, and 9 thru 11)
2	24 096 24	Cover, Air Cleaner
3	25 341 02	Knob, Cover
4	12 100 01	Wing Nut
5	24 380 03	Pin, Latch Lever (2)
6	24 096 01	Cover, Inner Air Cleaner
7	24 083 02	Element, Pre-Cleaner
8	47 083 03	Element, Air Cleaner
9	24 126 21	Bracket, Air Cleaner
10	24 126 43	Bracket, Air Cleaner
11	24 109 01	Cup, Fuel Spillback
12	24 041 13	Gasket, Fuel Spillback Cup
13	24 094 02	Base, Air Cleaner
14	24 041 14	Gasket, Air Cleaner Base
15	24 164 06	Manifold, Intake
16	24 041 01	Gasket, Intake Manifold (2)
17	M-0639055	Screw M6 x 1.0 x 18 (4)
NOT ILLUSTRATED		
--	12 113 53	Decal, Air Cleaner

NOTE: All component dimensions given in U.S. Inches
1 inch = 25.4 mm



REPAIR PARTS

TRACTOR -- MODEL NUMBER 917.251561

KOHLER ENGINE - MODEL NUMBER CV22S, TYPE NUMBER 67515

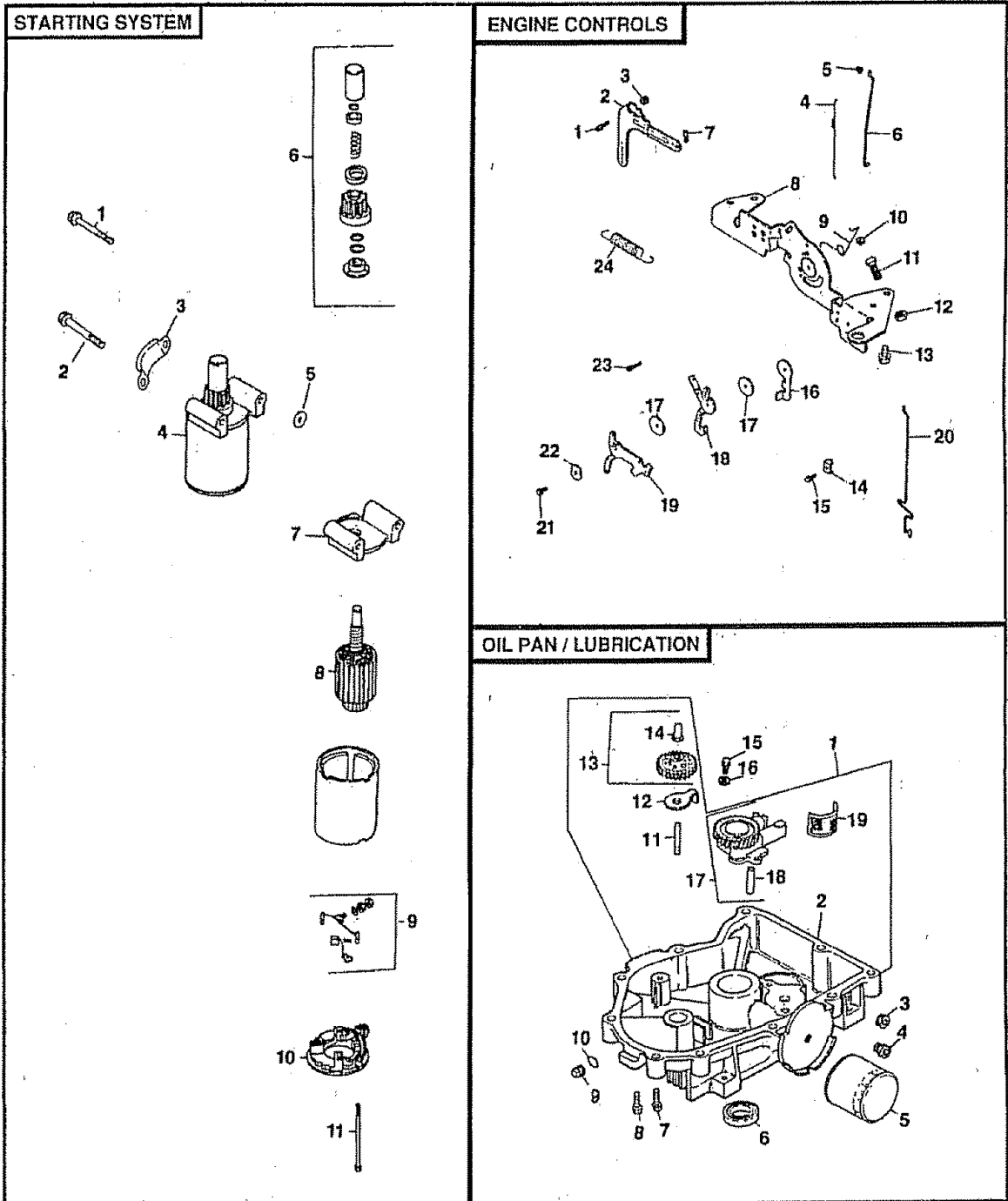

REPAIR PARTS

TRACTOR -- MODEL NUMBER 917.251561

KOHLER ENGINE - MODEL NUMBER CV22S, TYPE NUMBER 67515

STARTING SYSTEM

KEY PART NO. NO.	DESCRIPTION
1 M-0839070	Screw M8 x 1.25 x 70
2 M-0839080	Screw M8 x 1.25 x 80
3 24 096 05	Cover, Pinion
4 25 098 03	Starter Assembly (Includes 6-11)
5 12 468 01	Washer (3)
6 12 755 54	Kit, Drive End
7 12 227 06	Cap, Drive End
8 45 170 03	Armature
9 82 755 28	Kit, Brush and Spring
10 12 227 11	Cap, Commutator End
11 12 086 25	Bolt, Thru (2)

OIL PAN/LUBRICATION

KEY PART NO. NO.	DESCRIPTION
1 24 199 07	Oil Pan Assembly
2 24 199 04	Oil Pan
3 X-75-32	Plug, Hex, Countersunk, 3/8 N.P.T.F.
4 24 136 01	Nipple, Oil Filter
5 12 050 01	Filter, Oil
6 52 032 08	Seal, Oil (PTO End)
7 24 086 17	Screw, Oil Pan M8 x 1.25 x 45
8 24 086 16	Screw, Oil Pan M8 x 1.25 x 45 (9)
9 X-75-10	Plug, Solid, Square Head, 3/8 N.P.T.F.
10 24 153 08	O-Ring
11 12 144 02	Shaft, Governor Gear
12 52 448 02	Tab, Locking
13 24 043 12	Kit, Governor Gear with Pin (Includes Key Number 14)
14 12 380 01	Pin, Governor Regulating
15 M-0645025	Screw M6 x 1.0 x 25 (2)
16 SM-0631005	Washer, Plain (2)
17 24 393 08	Oil Pump Assembly (Includes 18)
18 24 123 05	Tube, Oil Pickup
19 25 162 07	Screen, Oil

ENGINE CONTROLS

KEY PART NO. NO.	DESCRIPTION
1 SM-0642025	Screw M6 x 1.0 x 25
2 24 090 14	Lever, Governor
3 SM-0641060	Nut M6 x 1.0
4 24 089 01	Spring, Linkage
5 25 158 08	Bushing, Linkage Retaining
6 24 079 04	Linkage, Throttle
7 25 158 11	Bushing, Throttle Linkage
8 24 126 13	Bracket, Control
9 24 089 03	Spring, Choke Return
10 M-0547050	Locknut, Hex M5 x 0.8
11 SM-0545016	Screw M5 x 0.8 x 16
12 M-0446030	Nut, Hex M4 x 0.7
13 SM-0645016	Screw M6 x 1.0 x 16 (4)
14 12 237 01	Clamp, Cable (2)
15 SM-0545016	Screw M5 x 0.8 x 16 (2)
16 24 090 07	Lever, Throttle Actuator
17 24 468 01	Washer (3)
18 24 090 13	Lever, Throttle Control
19 24 090 05	Lever, Choke
20 24 079 05	Linkage, Choke
21 SM-0545020	Screw M5 x 0.8 x 20
22 41 468 03	Washer, Wave
23 M-0403025	Screw M4 x 0.7 x 24
24 24 089 18	Spring, Governor

NOTE: All component dimensions given in U.S. inches
1 inch = 25.4 mm

REPAIR PARTS

TRACTOR - - MODEL NUMBER 917.251561

KOHLER ENGINE - MODEL NUMBER CV22S, TYPE NUMBER 67515

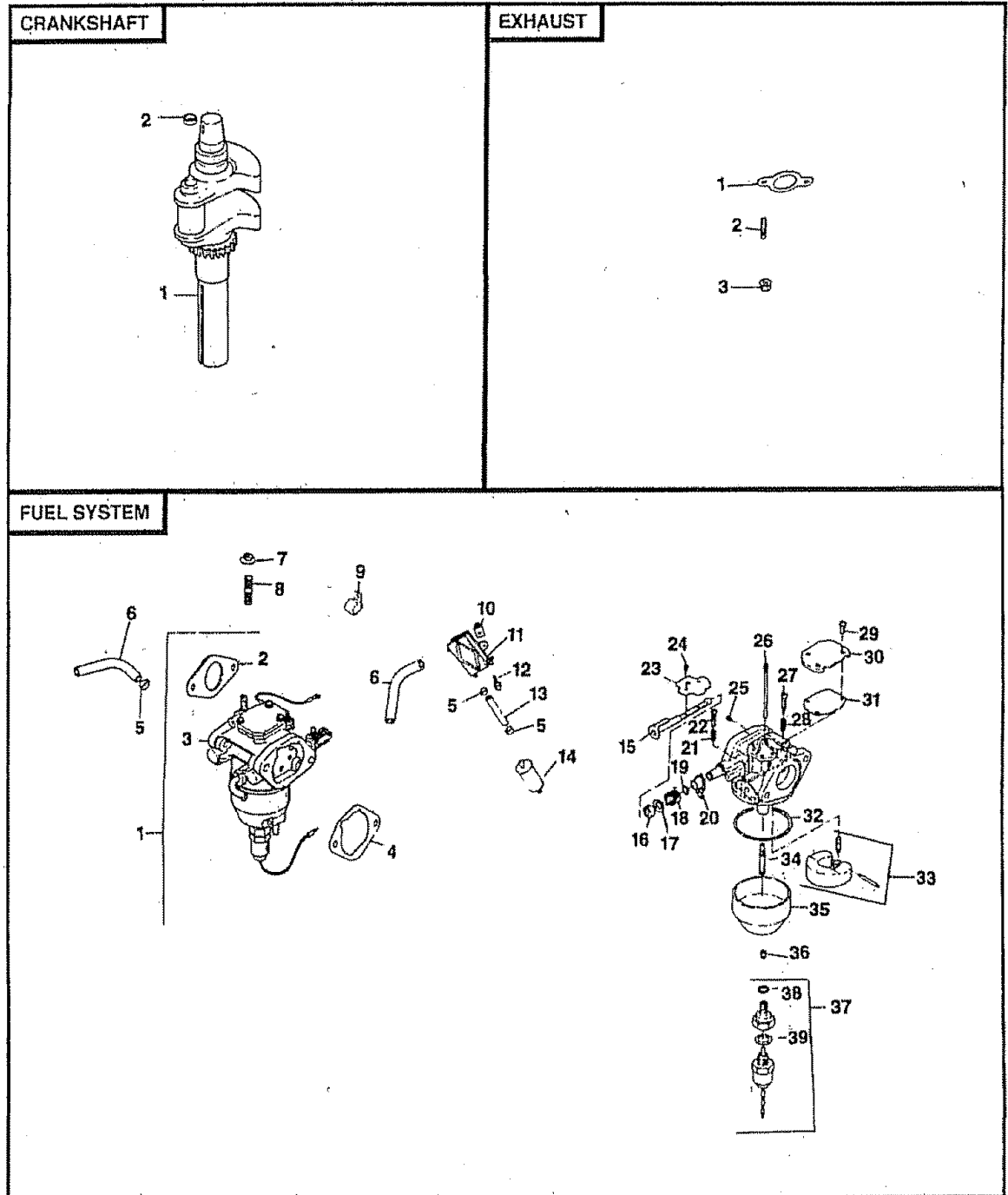

REPAIR PARTS

TRACTOR - - MODEL NUMBER 917.251561

KOHLER ENGINE - MODEL NUMBER CV22S, TYPE NUMBER 67515

FUEL SYSTEM

KEY PART NO.	NO.	DESCRIPTION
1	24 853 25	Kit, Carburetor with Gasket (Includes Key Numbers 2 thru 4)
2	24 041 15	Gasket, Carburetor
3	24 053 25	Carburetor Assembly (For Information Only, Not Available Separately) (Includes 15-39)
4	24 041 14	Gasket, Air Cleaner Base
5	X-426-9	Clamp, Hose (6)
6	24 353 03	Line, Fuel, 10-5/8" (2)
7	SM-0641060	Nut M6 x 1.0 (2)
8	M-0629095	Stud M6 x 1.0 x 95 (2)
9	47 154 01	Clip, Cable
10	24 100 01	Nut, Plastic (2)
11	24 393 04	Pump, Fuel, Pulse
12	24 086 12	Screw, Hex Cap Head (2)
13	25 353 03	Line, Fuel, 13-1/2"
14	25 050 02	Filter, Fuel
15	24 144 15	Shaft, Choke
16	24 468 05	Washer
17	24 241 01	Collar, Choke
18	24 089 22	Spring, Choke Return
19	24 141 04	Ring, Choke Lever
20	24 090 10	Lever, Choke
21	24 089 24	Spring, Throttle Adjust Screw
22	24 086 19	Screw, Throttle Adjust
23	24 462 02	Valve, Choke
24	24 086 20	Screw, Throttle and Choke Shaft (4)
25	24 337 27	Jet, Air Bleed
26	24 337 11	Jet, Slow
27	24 086 22	Screw, Idle Adjust
28	24 089 23	Spring, Idle Adjust Screw
29	24 086 21	Screw (3)
30	24 096 13	Cover, Passage
31	24 041 18	Gasket, Passage Cover
32	24 041 19	Gasket, Float Chamber
33	24 757 05	Kit, Float Repair
34	24 369 01	Nozzle, Main
35	24 234 01	Chamber, Float
36	24 337 28	Jet, Main
37	24 755 15	Kit, Solenoid Valve (Includes 38-39)
38	24 041 21	Gasket, Chamber Screw
39	24 041 20	Gasket, Solenoid
NOT ILLUSTRATED		
--	24 041 15	Gasket, Carburetor
--	24 757 06	Kit, Carburetor Repair
--	24 755 72	Kit, High Altitude (1500-3000 Meters)
--	24 755 73	Kit, High Altitude (Over 3000 Meters)

CRANKSHAFT

KEY PART NO.	NO.	DESCRIPTION
1	24 014 72	Crankshaft
2	52 139 09	Plug, Cup

EXHAUST

KEY PART NO.	NO.	DESCRIPTION
1	24 041 02	Gasket, Exhaust (2)
2	M-0829033	Stud, Exhaust Manifold M8 x 1.25 x 20 (4)
3	M-0841080	Nut, Muffler Mounting M8 x 1.25 (4)

NOT ILLUSTRATED

KEY PART NO.	NO.	DESCRIPTION
--	24 755 03	Gasket Set

RPM Settings: Low Speed: 1150-1650
High Speed: 3200-3400

NOTE: All component dimensions given in U.S. inches
1 inch = 25.4 mm



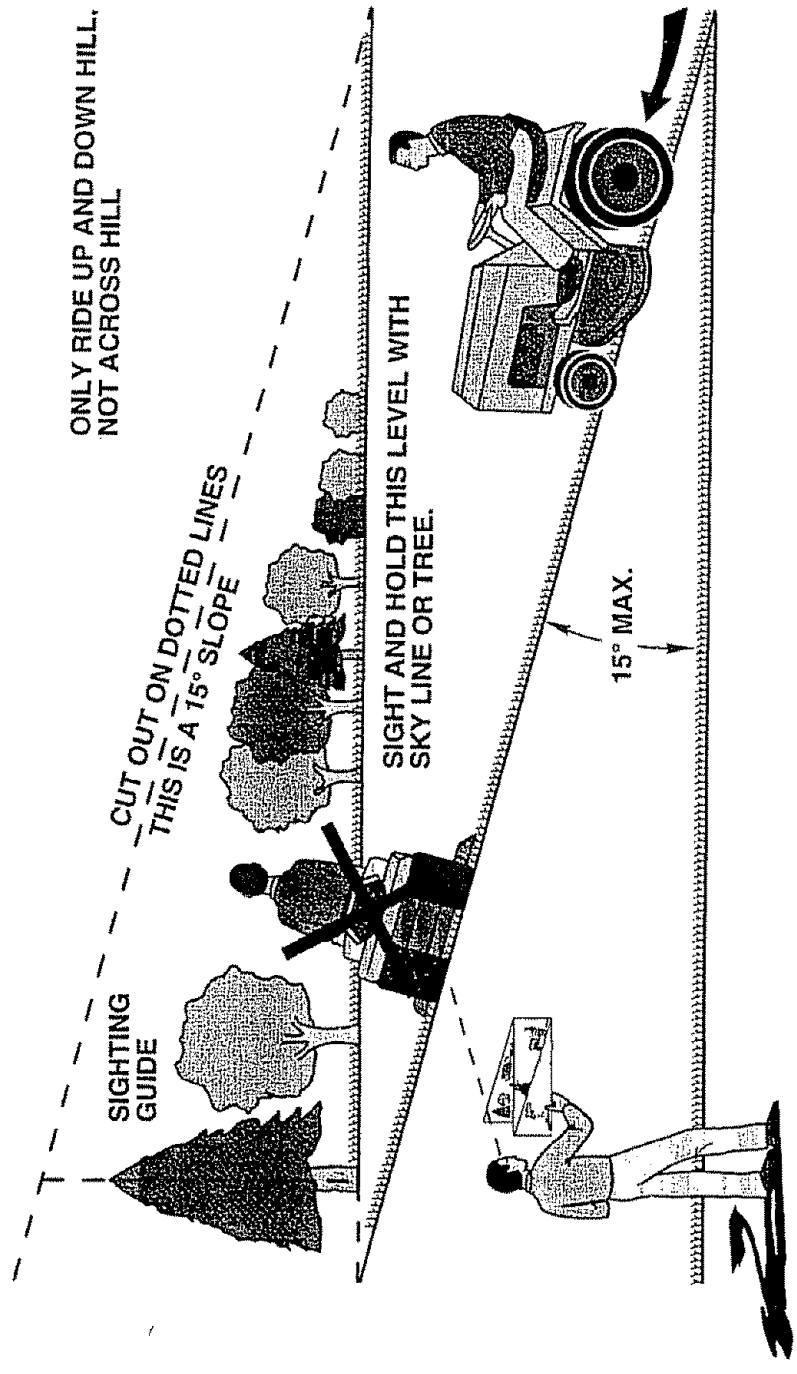

 Operate your Tractor up and down the face of slopes (not greater than 15°), never across the face. Make turns gradually to prevent tipping or loss of control. Exercise extreme caution when changing direction on slopes.

SEARS

**OWNER'S
MANUAL**

**MODEL NO.
917.251561**

**IF YOU NEED
REPAIR SERVICE
OR PARTS:**

FOR REPAIR SERVICE, CALL
THIS TOLL FREE NUMBER:

1-800-4-REPAIR
(1-800-473-7247)

FOR REPLACEMENT PARTS
INFORMATION AND
ORDERING, CALL THIS
TOLL FREE NUMBER:

1-800-FON-PART
(1-800-366-7278)

FOR CONSUMER ASSISTANCE
HOT LINE, CALL THIS
TOLL FREE NUMBER:

1-800-659-5917

CRAFTSMAN®

**22.5 HP TWIN CYLINDER
ELECTRIC START
50" MOWER
HYDROSTATIC (AUTOMATIC)
GARDEN TRACTOR**

Each tractor has its own model number. Each engine has its own model number.

The model number for your tractor will be found on the model plate located under the seat.

The model number for your engine will be found on the blower housing of the engine.

All parts listed herein may be ordered from any Sears, Roebuck and Co. Service Center/Department and most Retail Stores.

**WHEN ORDERING REPAIR PARTS, ALWAYS GIVE THE
FOLLOWING INFORMATION:**

- **PRODUCT - TRACTOR**
- **MODEL NUMBER - 917.251561**
- **ENGINE MODEL NO. - CV22-PS67515**
- **PART NUMBER**
- **PART DESCRIPTION**

Your Sears merchandise has added value when you consider Sears has service units nationwide staffed with Sears trained technicians.. professional technicians specifically trained to insure that we meet our pledge to you, we service what we sell