



PRO

Installation Instructions & Owner's Manual

Water Filters



For Models:

- APBF
- APIS

TABLE OF CONTENTS

Pre-Installation Instructions for Dealers	3
Bypass Valve	4
Installation	5
Programming Procedures	8
Startup Instructions	10
Operating Displays and Maintenance	11
Replacement Mineral Instructions for Acid Neutralizers	16
Troubleshooting Guide	18
Replacement Parts	23
Installation Fitting Assemblies	29
Specifications	31
Warranty	32
Quick Reference Guide	33

YOUR WATER TEST

Hardness _____ gpg
Iron _____ ppm
pH _____ number
*Nitrates _____ ppm
Manganese _____ ppm
Sulphur _____ yes/no
Total Dissolved Solids _____

*Over 10 ppm may be harmful for human consumption.
Water conditioners do not remove nitrates or coliform bacteria,
this requires specialized equipment.

PRODUCT INFORMATION

MODEL NUMBER _____

SERIAL NUMBER _____

DEALER INFORMATION:

Your A. O. Smith Pro Series water filter is a precision built, high quality product. These units will deliver filtered water for many years to come when installed and operated properly. Please study this manual carefully and understand the cautions and notes before installing. This manual should be kept for future reference. If you have any questions regarding your water filter, contact your local dealer.

PRE-INSTALLATION INSTRUCTIONS

The manufacturer has preset the water treatment unit's sequence of regeneration cycles and cycle times.

THE DEALER SHOULD...

- Read this page and guide the installer regarding day override and time of regeneration settings prior to installation.

THE INSTALLER SHOULD...

- Program installer settings including day override and time of regeneration.
- Read Operating Displays and Maintenance section.
- Set the time of day.
- Read Power Loss and Error Display section.
- Ensure that system and installation are in compliance with all state and local laws and regulations.

THE HOMEOWNER SHOULD...

- Read Programming Procedures section.
- Read Operating Displays and Maintenance section.

GENERAL OPERATING DISPLAYS & NAVIGATION

During normal operation, the default user displays are "time of day" and "gallons per minute". Flow rate, capacity remaining, and days to a regeneration are optional displays. For more explanation, consult the "operating displays and maintenance section". Pressing the **NEXT** button on a general operating screen will cycle through the available operating displays.

In any screen other than a general operating display, the **NEXT** button will proceed to the next step, the **REGEN** button will return to a previous step, and the **CLOCK** button will return to the general operating displays. Any changes made prior to the exit will be incorporated. If no buttons are pressed within five minutes, the display will return to the general operating displays.

DOUBLE REGENERATION

Two generations within 24 hours are possible with a return to the preset program. To initiate a double regeneration:

1. Press the **REGEN** button once. "REGEN TODAY" will flash on the display.
2. Press and hold the **REGEN** button for three seconds until a regeneration begins.

Once the valve has completed the immediate regeneration, the valve will regenerate once more during the preset time.

BYPASS VALVE

The bypass valve is typically used to isolate the control valve from the plumbing system's water pressure in order to perform control valve repairs or maintenance. The 1" full flow bypass valve incorporates four positions, including a diagnostic position that allows a service technician to have pressure to test a system while providing untreated bypass water to the building. Be sure to install bypass valve onto main control valve before beginning plumbing or make provisions in the plumbing system for a bypass. The bypass body and rotors are glass-filled Noryl® and the nuts and caps are glass-filled polypropylene. All seals are self-lubricating EPDM to help prevent valve seizing after long periods of non-use. Internal "O" Rings can easily be replaced if service is required.

The bypass consists of two interchangeable plug valves that are operated independently by red arrow shaped handles. The handles identify the direction of flow. The plug valves enable the bypass valve to operate in four positions.

- 1. NORMAL OPERATION POSITION:** The inlet and outlet handles point in the direction of flow indicated by the engraved arrows on the control valve. Water flows through the control valve for normal operation of a water softener or filter. During the regeneration cycle this position provides regeneration water to the unit, while also providing untreated water to the distribution system (**Fig. 1**).
- 2. BYPASS POSITION:** The inlet and outlet handles point to the center of the bypass. The system is isolated from the water pressure in the plumbing system. Untreated water is supplied to the building (**Fig. 2**).
- 3. DIAGNOSTIC POSITION:** The inlet handle points toward the control valve and the outlet handle points to the center of bypass valve. Untreated supply water is allowed to flow to the system and to the building, while not allowing water to exit from the system to the building (**Fig. 3**). This allows the service technician to test the unit and perform other functions without disrupting the water going to the building.

NOTE: The system must be rinsed before returning the bypass valve to the normal position.

- 4. SHUT OFF POSITION:** The inlet handle points to the center of the bypass valve and the outlet handle points away from the control valve. The water is shut off to the building. The water treatment system will depressurize upon opening a tap in the building. A negative pressure in the building combined with the unit being in regeneration could cause a siphoning to the building. If water is available on the outlet side of the unit, it is an indication of water bypassing the system (**Fig. 4**) (i.e. a plumbing cross-connection somewhere in the building).

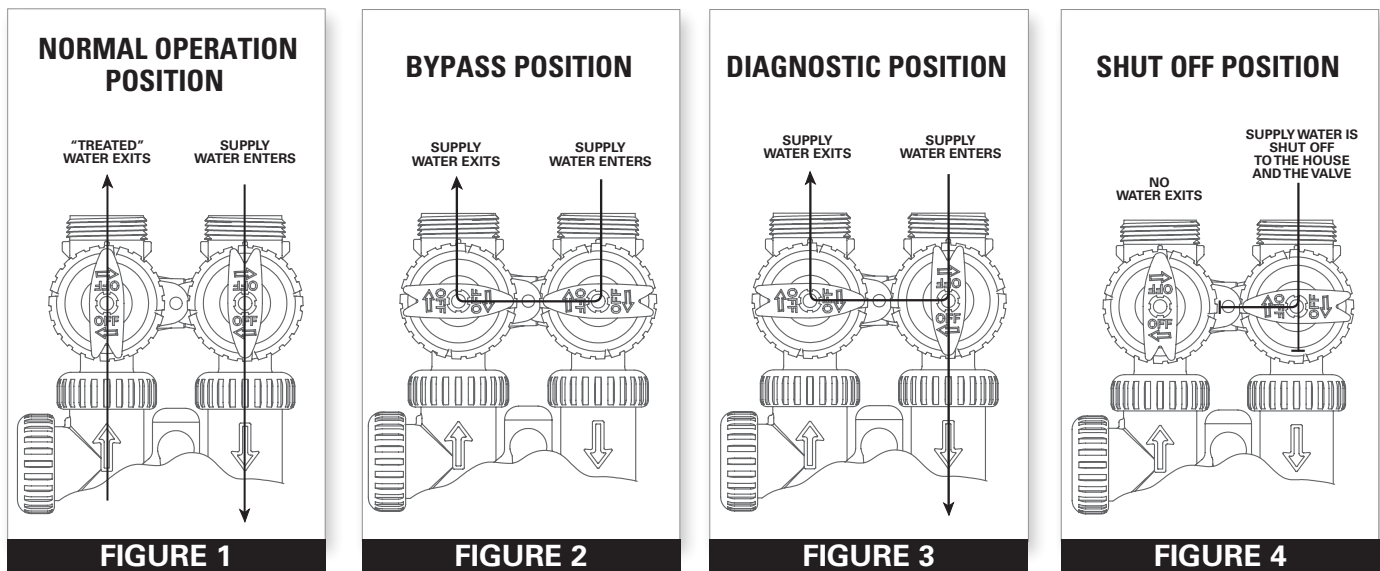

INSTALLATION

GENERAL INSTALLATION & SERVICE WARNINGS

The control valve, fittings and/or bypass are designed to accommodate minor plumbing misalignments. There is a small amount of “give” to properly connect the piping, but the water treatment unit is not designed to support the weight of the plumbing.

Do not use petroleum jelly, oils, other hydrocarbon lubricants, or spray silicone anywhere. A silicone lubricant may be used on black “O” Rings, but is not necessary. **Avoid any type of lubricants, including silicone, on red or clear lip seals.**

Do not use pipe dope or other sealants on threads. Plumber’s tape must be used on the threads of the 1” NPT inlet and outlet and on the threads for the drain line connection. Plumber’s tape is not used on the nut connections or caps because “O” Ring seals are used. The nuts and caps are designed to be unscrewed or tightened by hand or with the special plastic Service Wrench, #100249864 (CV3193-02). If necessary, pliers can be used to unscrew the nut or cap. Do not use a pipe wrench to tighten nuts or caps. **Do not place screwdriver in slots on caps and/or tap with a hammer.**

SITE REQUIREMENTS

- Water pressure – 25-100 psi
- Water temperature – 33-100°F (0.5-37.7°C)
- Electrical – 115/120V, 60Hz uninterrupted outlet
- Current draw is 0.5 amperes
- The plug-in transformer is for dry locations only

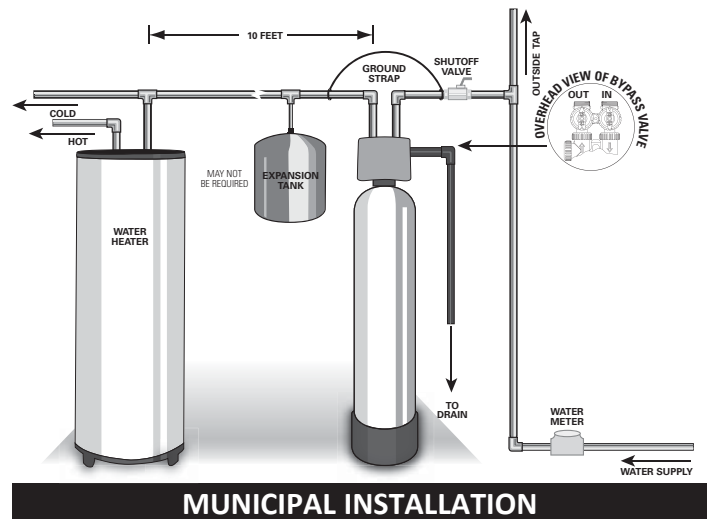
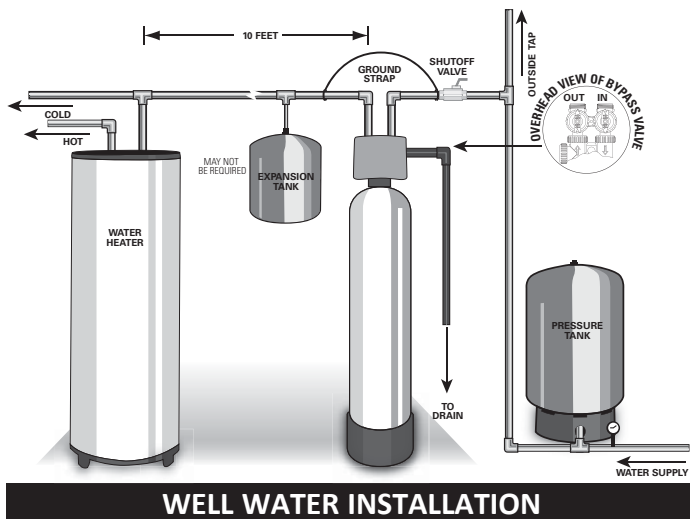

1. The distance between the drain and the water conditioner should be as short as possible (see #8).
2. The media tank should be installed on a firm, level surface (above or below grade).
3. It is NOT recommended to install any water treatment unit with less than 10 feet of piping between its outlet and the inlet of a water heater.



CAUTION: To protect the unit in the event of a hot water heater backup, the manufacturer recommends the use of an expansion tank on the outlet side of the unit (see diagram).

4. Do not locate unit where it or its connections (including the drain and overflow lines) will ever be subjected to temperatures under 33°F.
5. Do not subject the tank to any vacuum as this may cause an “implosion” and could result in leaking. If there is a possibility a vacuum could occur, please make provision for a vacuum breaker in the installation.
6. **INLET/OUTLET PLUMBING:** Be sure to install Bypass Valve onto main control valve before beginning plumbing. If it is desired to bypass outside hydrants, a cold water kitchen sink, or other locations, provisions should be made at this time. Install an inlet shutoff valve and plumb to the unit’s bypass valve inlet located at the right rear as you face the unit. There are a variety of installation fittings available. They are listed under the Installation Fitting Assemblies section of the manual. When assembling the installation fitting package (inlet and outlet), connect the fitting to the plumbing system first and then attach the nut, split ring and “O” Ring. Heat from soldering or solvent cements may damage the nut, split ring or “O” Ring. Solder joints should be cool and solvent cements should be set before installing the nut, split ring and “O” Ring. Avoid getting solder flux, primer, and solvent cement on any part of the “O” Rings, split rings, bypass valve or control valve. If the building’s electrical system is grounded to the plumbing, install a copper grounding strap from the inlet to the outlet pipe. Plumbing must be done in accordance with all applicable local codes.

When installing an air regenerating filter the customer may experience, under certain conditions, small amounts of air (cloudy water) at the taps. This is normal. On rare occasions, this may result in “shots of air” at a particular fixture. By installing a loop or “U” on the outlet side of the unit, this will act as an air trap and improve this situation.

An internal check valve is located inside the inlet on air filtration units (see diagram at right). This check valve holds the air in the system, preventing its escape from the tank. Plumbing codes may require the installation of a thermal expansion tank on the outlet side of the system to prevent a water heater backup condition.

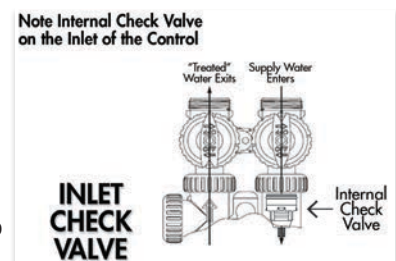

INSTALLATION

Provisions should be made to bypass outside hydrants that are not to have filtered water. It is also advisable to install hose bibs on the inlet and outside of the filter for future testing and service of the equipment. Where heavy sediment from the well is observed, it is advisable to install a cartridge or bag-style filter immediately upstream from the filter. A nominal micron rating of 50 to 100 is recommended. The purpose of this is to protect the control valve of any debris from the well. If desired, a cartridge filter may be used after the system as a polishing filter.

7. **INSTALLING GROUND:** To maintain an electrical ground in metal plumbing of a home's cold water piping (such as a copper plumbing system), install a ground clamp or jumper wiring.

NOTE: If replacing an existing unit, also replace the ground clamps/wire. If removing a unit, replace the piping with the same type of piping as the original to assure plumbing integrity and grounding.

8. **DRAIN LINE:** First, be sure that the drain can handle the backwash rate of the system. Solder joints near the valve must be done prior to connecting the drain line flow control fitting. Leave at least 6" between the drain line flow control fitting and solder joints. Failure to do this could cause interior damage to the flow control.

Backwash of an automatic filter can be directed into a septic tank in most cases, but because of the higher volume of water discharged, care should be taken. The backwash discharge can be directed to a subsurface drainage system or other safe location. Remember to follow all local codes.

When installing the drain line on any backwashing filter, especially filters that utilize air as the regenerant, hard piping such as PVC, Schedule 80 Plastic or copper is recommended. Remove the drain line nut (if included) and discard. A 3/4" NPT connection on the elbow is provided. **During backwash, high volumes of water (more than a softener) and air can be expelled. This release of air can cause a thrashing or movement of the drain line causing it to dislodge from the drain, resulting in water damage. In order to prevent this, it is recommended to use other means of securing the drain line to the floor, wall or ceiling to avoid this thrashing of piping.** Our patent pending Backwash Air cycle greatly reduces the chance of this occurring but should not be the only means of protection.

Where the drain line is elevated but empties into a drain below the level of the control valve, form a 7" loop at the discharge end of the line so that the bottom of the loop is level with the drain connection on the control valve. This will provide an adequate anti-siphon trap. Piping the drain line overhead <10 ft is normally not a problem. Be sure adequate pressure is available (40-60 psi is recommended). Where the drain empties into an overhead sewer line, a sink-type trap must be used. Run drain to its discharge point in accordance with plumbing codes. Pay special attention to codes for air gaps and anti-siphon devices.



CAUTION: Never insert a drain line into a drain, sewer line, or trap. Always allow an air gap of 1-1/2" or twice the pipe diameter, whichever is greater, between the drain line and the wastewater to prevent the possibility of sewage being back-siphoned into the unit.

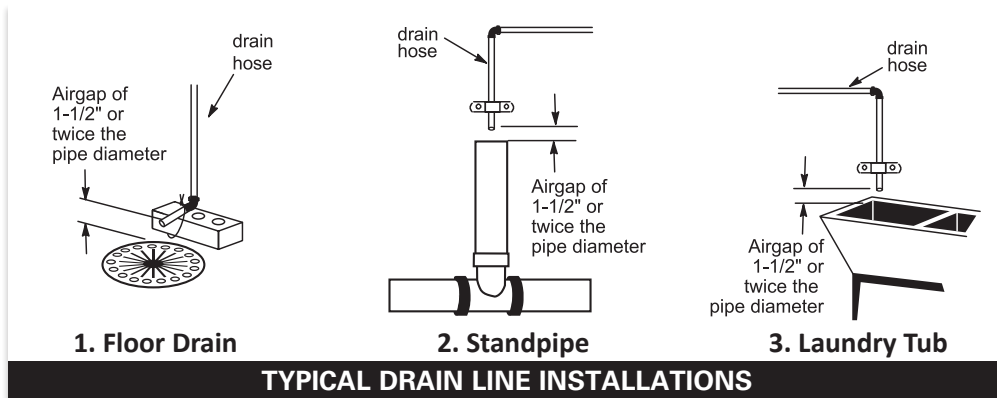
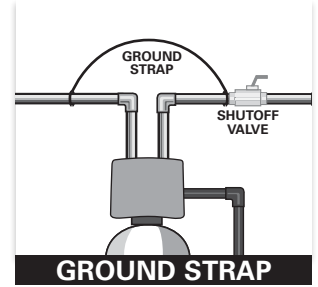

INSTALLATION

9. **CHECK VALVE (AIR FILTRATION SYSTEMS ONLY):** All air systems include an internal check valve and screen assembly as part of the air draw system (see diagram at right). This check valve, screen, and elbow are exclusive to the air system and are not to be confused or interchanged with a brine elbow used on a softener. The gray color of the elbow indicates use with an air system vs. a black elbow which indicates use with a water softener.

NOTE: Under certain conditions (finished basements, utility room, etc.) it may be advisable to disconnect the screen and run a 3/8" line close to a drain, in case of check valve failure and water leakage.



CAUTION: Check valve may be under pressure and can result in sudden release of part, causing injury.

In order to replace or remove the check valve from the control valve, it is necessary to relieve the pressure from the system. Place filter into by-pass mode (Fig. 2 Page 4) and release pressure by manually stepping through an entire regeneration sequence. This will adequately release the pressure on the system so the check valve can be serviced. After servicing, replace part, secure the check valve assembly with the red clip. Open by-pass to the normal service position (Fig. 1 Page 4).

10. **OZONE GENERATOR KIT:** In situations where additional cleaning is needed due to high levels of iron or sulfur bacteria, an Ozone Generator (part # 100349795, OZ-1-A) may be beneficial. This device produces ozone, a powerful cleaning agent which is used to help reduce service calls due to nuisance bacteria*. Please consult with your local dealer or distributor for more information.

*Nuisance bacteria refers to iron and sulfate reducing bacteria which is harmless to human health. This bacteria can cause slime, taste, and odor issues.

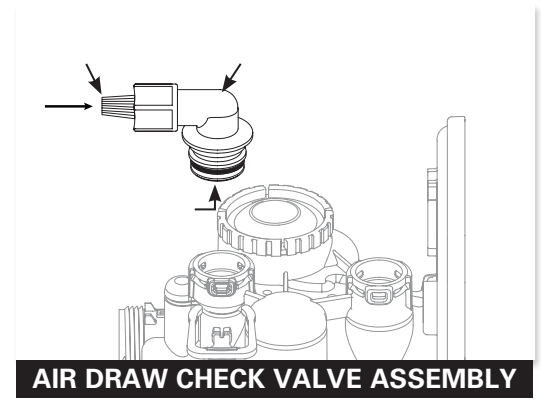

PROGRAMMING PROCEDURES

1. Set Time of Day

Typically, time of day should only need to be set after extended power outages or when daylight saving time begins or ends or after the battery has been replaced. If an extended power outage occurs, the time of day will flash on and off indicating that the time should be reset. To set the clock:

STEP 1 – Press the **CLOCK** button.

STEP 2 – Set the hour of the day using **+** or **-** buttons. AM/PM toggles after 12. Press **NEXT** to go to step 3.

STEP 3 – Set the minutes using **+** or **-** buttons. Press **NEXT** to go to step 4 or **REGEN** to return to previous step.

STEP 4 – Set the day of the week using **+** or **-** buttons. Press **NEXT** to exit clock setting or **REGEN** to return to previous step.

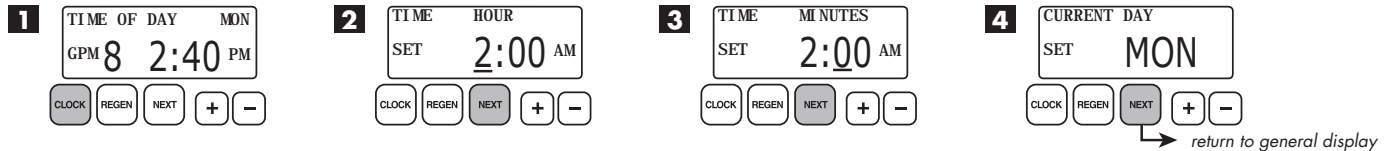

2. Programming

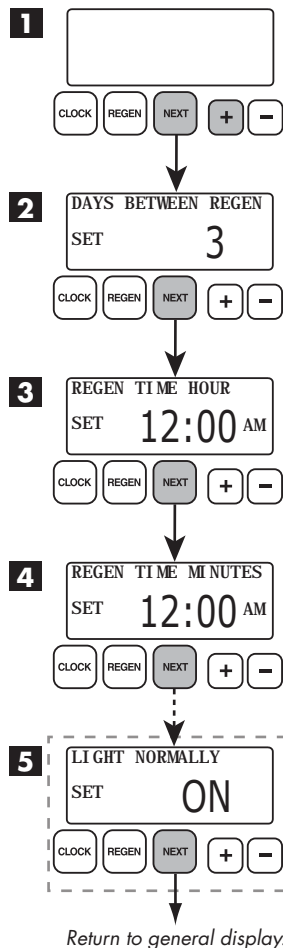

Press **NEXT** to cycle to the next step or **REGEN** to return to the previous step.

STEP 1 – Press and hold the **NEXT** and **+** buttons simultaneously for 3 seconds.

STEP 2 – DAYS BETWEEN REGENERATION (DAY OVERRIDE): Use the **+** or **-** buttons to adjust the day override. Adjustable from 1-28 days or OFF. The manufacturer has factory set 3 days as the default.

The Day Override value represents the maximum number of days between regenerations. If any number is set (1-28 days), a regeneration will be scheduled for that day if the gallon capacity has not been met. If OFF is set, the unit will only initiate a regeneration once the gallon capacity has been met.

STEP 3 – REGENERATION HOUR: Use the **+** or **-** buttons to adjust the time of day the unit will regenerate. AM/PM toggles after 12. The manufacturer has factory set 12:00 A.M. as the default setting which is recommended for a normal household.

STEP 4 – REGENERATION MINUTES: Use the **+** or **-** buttons to set minutes.

STEP 5 – BACKLIGHT DISPLAY CONTROL: Use the **+** or **-** buttons to turn the backlight setting ON or OFF. If unit is set to OFF, the backlight will turn off after 5 minutes of inactivity. **This setting is not available on all models.**

Press **NEXT** to return to General Display.

OZONE GENERATOR PROGRAMMING

1. Unlock Controller

Once the ozone generator has been properly installed, it must be turned on and programmed in the controller's settings prior to operation. Settings for ozone generators takes place in the Service/OEM Filtering level of programming.

To access the Service/OEM Filtering level, the control valve must first be unlocked. Controllers are factory set in the locked position to avoid any unwanted access to programming parameters.

STEP 1 – To unlock the controller, press **–**, **NEXT**, **+**, and then **CLOCK** in that order. The screen will read "UNLOCK" if the sequence is inputted correctly from a general operating screen. Following the programming procedures below, re-lock the controller by inputting the same sequence.

STEP 2 – Once unlocked, press and hold the **NEXT** and **–** buttons simultaneously for three seconds to access the "Service/OEM Filtering" screens below.

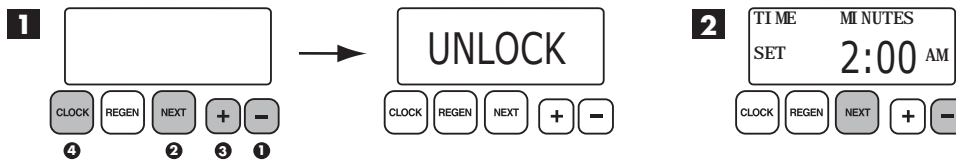

2. Programming

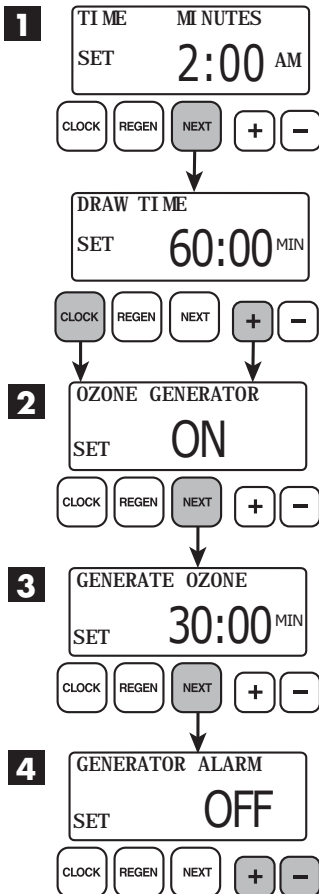

STEP 1 – Press **NEXT** to advance to the "Draw Time" screen.

On the "DRAW TIME" screen, press and hold the **CLOCK** and **+** buttons simultaneously for three seconds to access Ozone Generator Settings.

STEP 2 – Use the **+** or **–** buttons to select **ON**. This turns the Ozone Generator on.

STEP 3 – Determine how long the ozone generator will run. The default is 30 minutes. Adjust the time as needed and press **NEXT**.

STEP 4 – Use the **+** or **–** buttons to turn alarm **ON** or **OFF**. When **ON**, a **SERVICE OZONE** message will display when failure is detected.

STARTUP INSTRUCTIONS

FLUSHING OF SYSTEM:

To flush the system of any debris and air after installation is complete, please perform the following steps:

1. Rotate bypass handles to the bypass mode (see Fig. 2 of page 4).
2. Turn on inlet water and check for leaks in the newly installed plumbing.
3. Fully open a cold water faucet, preferable at a laundry sink or bathtub without an aerator.
4. Wait two to three minutes or until water runs clear, then turn water off and follow start-up instructions.

System regeneration sequence is in the following order. Some sequence differences may be noticed depending upon local conditions. (If it is desired to change this sequence, please contact the manufacturer.)

Sequencing for Various Filters:

Air Filters (Iron & Sulfur)

1. Backwash Air
2. Backwash
3. Regenerant Draw Down (Air draw)
4. Return to service

Inch Worm Feature:

Air filter units are programmed with the backwash air cycle feature (nicknamed "inch worm"). This unique feature allows for small movements or "inching" of the piston towards the backwash cycle. As the piston approaches this cycle, the backwash port opens slightly with each advancement, allowing air to escape to drain. This cycle is twelve very small mini steps of the piston which take place twenty seconds apart. Usually midway between the twelve positions, the air begins to be released very slowly to the drain in normal operating conditions.

When first starting up an air sulfur or air iron, it is advised to step through these positions and go to the normal backwash cycle in order to fill the unit.

To Advance in Backwash Air Cycle:

1. Pushing the **NEXT** button will advance to each of the twelve mini steps within the backwash air cycle. While there are usually twelve steps to this cycle, the valve may make two or three movements for each step. Wait for these movements to complete before pressing **NEXT** again.
2. Pushing and holding the **REGEN** button for three seconds while in the Backwash Air cycle will skip the remaining mini steps and proceed to the next cycle of regeneration which is usually Backwash.

The system is now ready for filling with water and for testing for Air Filters.

NOTE: The "filling" sequence below represents the start-up procedure for Air Filters.

Please reference "Sequence for Various Filters" for proper regeneration sequence (shown above).

1. Place the bypass valve into the bypass mode (Fig. 2 on page 4).
2. Press and hold the **REGEN** button until the motor starts. Release button. Put the valve into "BACKWASH" position. (Please see note above.) Unplug the transformer so that the valve will not cycle to the next position. Open the inlet handle of the bypass valve very slightly allowing water to fill the tank slowly in order to expel air.



CAUTION: If water flows too rapidly, there will be a loss of media to the drain.

Certain medias such as carbon, or other dry medias, should not be backwashed immediately for extended periods of time. These medias need to "soak" in the water for a 24-hour period prior to full backwash conditions.

Dry media exposed to water too quickly in backwash will result in media plugging the drain and valve assembly.

3. After the water is flowing steadily to the drain, clear and without the presence of air, slowly open the inlet valve. Restore power and momentarily press the **REGEN** button to advance the control to the "REGENERANT DRAW DOWN" position.
4. With the bypass still in the diagnostic mode (Fig. 3 on page 4), there should be a slow flow to the drain.
5. Press **REGEN** button in sequence until display returns to "TIME." Place bypass valve in the normal operating mode (Fig. 1 on page 4) by opening the outlet bypass handle.

6. CONDITIONING OF MEDIA:

To flush any remaining debris and air from the system again:

1. Turn on a cold water faucet wide open, preferably at a laundry sink or bathtub without an aerator.
 2. Wait two to three minutes or until water runs clear, then turn water off.
 3. Turn on hot water and check for air, then turn water off after air is discharged.
7. Place unit into regeneration and allow to complete a full cycle. Upon completion, unit will deliver treated water.

OPERATING DISPLAYS AND MAINTENANCE

The air sulfur and air iron filter systems look and function much like any backwashing whole house filter; however, unlike these conventional filters, they use air as a regenerant. This atmospheric air (containing oxygen) helps convert iron or hydrogen sulfide into particles. These filters capture the particles of iron or hydrogen sulfide gas within the filter media. Your dealer has recommended the proper media depending on your local water conditions. In some cases where an acidic water condition (low pH) is present, the media may need to be periodically replenished if using this filter to raise the pH to an acceptable level. Consult dealer for this service. The system is pre-factory set to regenerate every (3) three days at midnight. The frequency and start time of backwash/regeneration is adjustable to meet local operating conditions and contaminant levels. Total backwash and recharge time may vary between one half hour to one hour and fifteen minutes depending on the unit configuration

1. GENERAL OPERATION: When the system is operating, one of five displays may be shown and will alternate with the installing dealer's name and phone number for future service. Pressing **NEXT** will alternate between the displays.

1. **Time of Day Screen:** Displays the current time of day, the day of the week, and flow rate.
2. **Flow Rate Screen:** Displays the current treated water flow rate through the system in Gallons Per Minute.
3. **Capacity Remaining Screen:** Displays the amount of gallons of treated water remaining until the system triggers a regeneration.
4. **Days to a Regen Screen:** Displays the number of days until the system triggers a regeneration. Based on the days override value.
5. **Dealer Name Screen:** Displays dealer specific name and phone number. This scrolling display will only appear if set by the dealer.

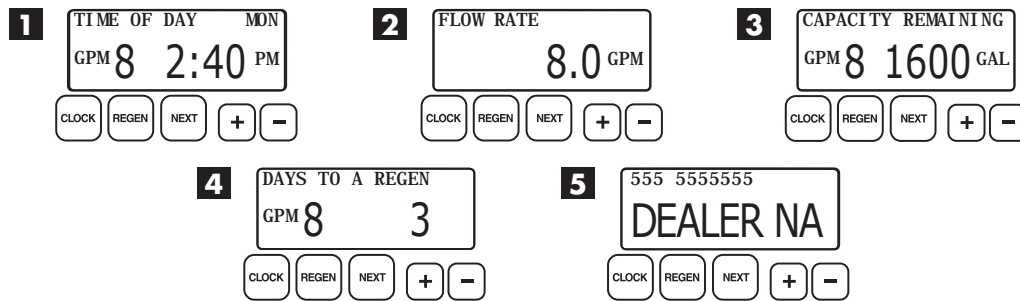

If the system has called for a regeneration that will occur at the preset time of regeneration, the words "REGEN TODAY" will appear on the display. If a water meter is installed, "GPM" flashes on the display when water is being treated, indicating gallons per minute flowing through the system.

2. REGENERATION MODE: Typically, a system is set to regenerate at a time of no water usage. If there is a demand for water when the system is regenerating, untreated water will be delivered. When the system begins to regenerate, the display will include information about the step of the regeneration process and the time remaining for that step to be completed. The system runs through the steps automatically and will reset itself to provide treated water when the regeneration has been completed.

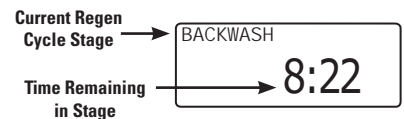

REGENERATION MODE

3. MANUAL REGENERATION: Sometimes there may be a need to regenerate a unit before the control valve calls for it. This may be needed if a period of heavy water use is anticipated.

- To initiate a manual regeneration at the next preset regeneration time, press and release the **REGEN** button. The words "REGEN TODAY" will flash on the display to indicate that the system will regenerate at the scheduled regeneration time (see the Programming Procedures section). If you pressed the **REGEN** button in error, pressing and releasing the button again will cancel the command.
- To initiate a manual regeneration immediately, press and hold the **REGEN** button for three seconds. The system will begin to regenerate immediately. **This command cannot be canceled.**

REGEN TODAY and TIME OF DAY will flash alternately if a regeneration is expected tonight.

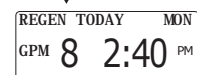

MANUAL REGEN

Once a manual regeneration is initiated, the unit will enter the first regeneration cycle position. Once the unit advances to its first position and subsequent positions thereafter, (see Start Up Instructions for regeneration sequence) the water filter will deliver water, but it will be untreated.

OPERATING DISPLAYS AND MAINTENANCE

4. POWER LOSS AND BATTERY REPLACEMENT: If an extended power outage occurs, the control valve will retain the time of day settings until the board's battery is depleted. Once the battery is depleted, the display will appear dark and absent of any information. If this occurs, following these steps will determine if the problem is a low battery or a board failure.

To determine if the battery is depleted:

1. Remove valve cover. Disconnect power from PC Board at the four pin connector at the bottom of the board.
2. Wait five minutes for board to de-energize. Remove battery with a non-conductive/non-metallic material. Reference the Parts Breakdown section of this manual for location.
3. Wait five minutes for board to de-energize.
4. With the battery out, re-connect the power supply to the board. The board's display should begin to show information.

This indicates that the board is operating correctly. If the display does not work, call installing dealer for service.

5. To replace with new battery, unplug transformer from outlet. Install a 3 volt Lithium Coin Cell type 2032 battery, available at most stores. Plug unit back into outlet.

It is important to replace the battery with the valve unplugged to avoid causing a short and potentially ruining the board.

6. Reset the time of day (see programming procedures) and initiate regeneration (see operating displays and maintenance).

If these procedures do not remedy the problem, please consult the installing dealer for service.

5. ERROR MESSAGE: If the word "ERROR" appears and flashes alternately with the dealer name and phone number, record the ERROR number and contact your servicing dealer promptly. This indicates that the control valve was not able to function properly.

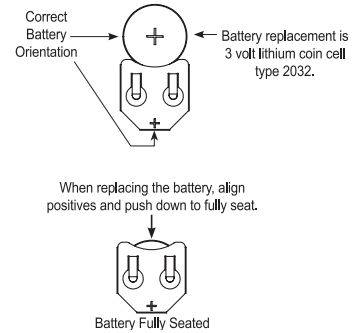

BATTERY REPLACEMENT



ERROR SCREEN

OZONE GENERATOR MAINTENANCE

For optimal performance, it is necessary to perform yearly maintenance on the filter and ozone generator in use by replacing the ozone check valve and injector. Failure of the check valve may result in water flowing to the ozone generator. This may, in turn, result in the failure of the generator and cause water damage to the surrounding area.

When three consecutive regenerations occur where the recorded amperage of the generator is below 200mA or above 400mA, the generator will signal an alarm and will require maintenance. A "Service Ozone" indicator will appear on the screen of the valve controller which signals that a cell needs replacement or a potentiometer adjustment. This maintenance should be performed by the servicing dealer. Follow the instructions below to determine the cause behind an Ozone Generator alarm.

SERVICE OZONE

SERVICE OZONE SCREEN

1. CHECK OZONE HISTORY

When on and functioning correctly, the valve controller records a snapshot of the voltage and amperage of the ozone generator for the past 50 regenerations. It is important to check these statistics to determine how the generator was performing prior to the alarm being triggered. These stats can be accessed via the first-level history area of the controller programming. To access it:

1. From a general operating screen, press and hold the + and - buttons simultaneously for three seconds.
2. Once the screen changes, press **NEXT** until the Ozone Generator history screen displays. **NOTE: If the Ozone Generator History screen does not display, ensure that the ozone generator has been turned on in the programming.**
3. Use the + or - buttons to view ozone generator performance during the last 50 regenerations. A regen sequence indicator (A) will alternate being viewed with "mA" if the Alternate Regen Feature was active for this regen. Regens with multiple regenerate draws will only record the first one in the sequence.

The normal operating amperage should be between 220mA and 260mA. The normal operating voltage should be between 12.0 and 12.1. When viewing the generator history, be aware of these values and note any anomalies.

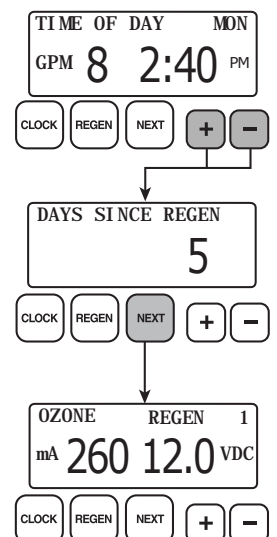

OZONE GENERATOR MAINTENANCE

2. ADJUST THE POTENTIOMETER

If the recorded amperage or voltage is outside of normal levels, the potentiometer may need to be adjusted. This dial is accessible on the back of the ozone generator unit once removed from its enclosure and can be adjusted using a screwdriver. To access and adjust, follow the steps below.

1. Remove the cover of the ozone generator enclosure by pulling it upward.
2. Locate the Potentiometer on the back of the generator internals. Using a screwdriver, turn the potentiometer dial fully clockwise. The potentiometer dial controls the amount of amperage being supplied to the board to the generator. Turning it fully clockwise will supply the lowest amperage to the generator.
3. On the controller, press and hold the **REGEN** button until a manual regeneration is initiated. Press the **REGEN** button to cycle through regeneration steps until the "Regenerant Draw Down (Air-Draw)" step is reached.
4. Wait on the "Regenerant Draw Down" Screen for ten seconds. Press and hold the **UP** and **DOWN** buttons for three seconds to reach the "Ozone generator live-view" screen.
5. The live-view screen provides a live reading of the amperage and voltage being supplied to the generator. The ozone generator should read between 220mA-260mA and 12.0VDC-12.1VDC. Using a screwdriver, gently turn the potentiometer dial counter-clockwise. Continue to turn the dial until the amperage is within the 220mA-260mA range. Confirm that the voltage reading is either 12.0 or 12.1.

NOTE: Turning the dial too far in the counter-clockwise position can force the generator to shut down (399mA or over). If this occurs, the controller screen will appear frozen. Press and hold the **NEXT** and **REGEN** buttons for three seconds to reboot the board. Once the controller reboots, return to **STEP 3** and continue.

6. Once the amperage and voltage are within acceptable ranges, press the **NEXT** button on the controller to exit the live-view. Replace the enclosure cover.

- If successful, the unit will resume normal operation and the alarm will cease.
- If moisture is suspected to have affected the cell, such as with a check valve failure or the result of environmental conditions, leave the cell to dry by resuming normal operation. In some cases, the electrical current running through the cell can dry it, restoring it to its normal functionality.
- If the alarm continues after three consecutive regenerations, it is advised to replace the cell.

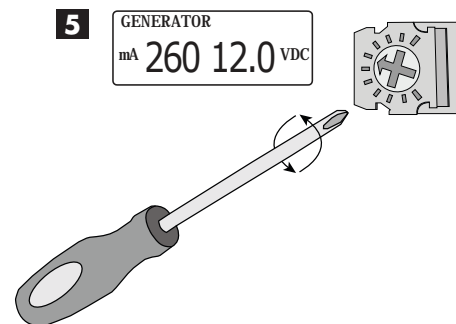
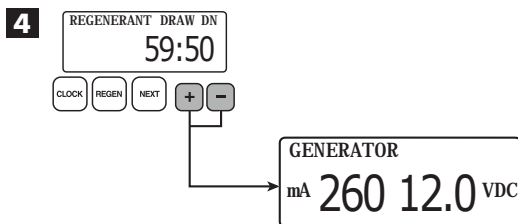
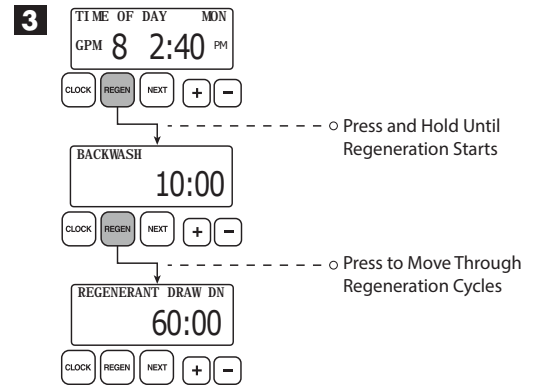
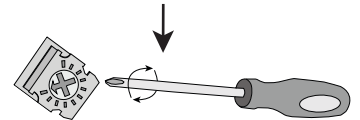
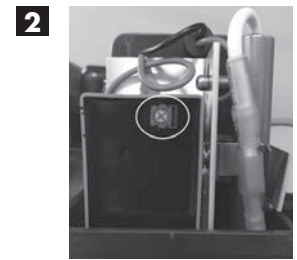

OZONE GENERATOR MAINTENANCE

3. REPLACE THE CELL

Over time, the ozone generator cell will become clogged with debris, will lose its generating capabilities, and will require replacement. If adjusting the potentiometer does not solve an ozone alarm issue, replacing the cell is necessary.

1. Disconnect the unit from power by unplugging the 110V transformer from its power supply.
2. Remove the cover of the ozone generator enclosure.
3. Remove the ozone generator internal components from the enclosure. Flip internals over to reveal a screw on the back. Using a screwdriver, remove and set aside the screw and the cell clip.
4. Detach the current ozone cell from the generator by pulling connectors apart and removing it from the cell clip by pulling away from the generator.
5. Attach new cell to the wire connectors and insert it into the clip. Re-attach the cell clip and replace the enclosure cap.
6. Reconnect the 110V transformer to its power supply.

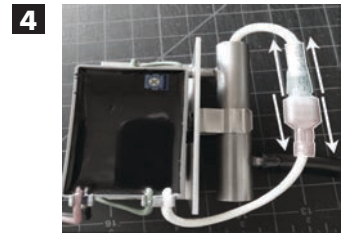
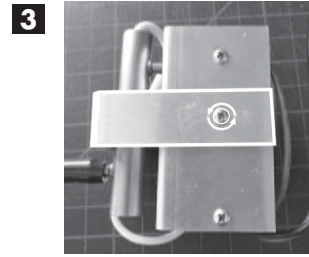

4. REPLACE THE OZONE CHECK VALVE AND INJECTOR

Replacement of the check valve and the injector is required yearly for optimal performance of the ozone generator and filter. This yearly maintenance also prevents check-valve related failure, which can cause significant water damage to the filtration unit and the area surrounding it.

1. Using a service wrench, loosen and remove the injector cap.
2. Pull out and dispose of the existing injector. Install the replacement.
3. Loosen the nut and remove the hose connected to the existing air-check elbow.
4. Remove the red clip and pull upwards on the air-draw elbow to remove it. Install the new air-draw elbow by pushing it down into the port and inserting the red clip until it clicks.



REPLACEMENT MINERAL INSTRUCTIONS FOR ACID NEUTRALIZERS

Acid Neutralizers raise the pH of mildly acidic water. The raising of pH utilizes a sacrificial mineral that will need replenishment every 6 to 12 months. Typically the media should not be below the halfway point in the tank. In order to check the mineral height and before adding mineral to the system, please follow these instructions.

For Automatic Backwash Filters With Dome Hole

1. Check the media height by shining a flashlight through the tank to see the height of the mineral. If the level is not visible, the top fill plug will have to be removed (if available) to measure the height. The media tank should only be two-thirds full (see diagram). Proceed to step 2.
2. To remove top fill plug, turn off the source of the water and open a conditioned water tap to relieve the water pressure on the system. Place unit into the bypass mode. Unscrew the top fill plug.



Caution: Never unscrew top fill plug unless pressure is fully released from system. Serious injury and/or flooding can occur.

3. Siphon out some water from the tank through the dome hole. This will allow room when adding the media.
4. Add the appropriate amount of replacement media through the dome hole (top fill plug). Make sure you add the correct amount and type of media (calcite or calcite/corosex mix). If needed, siphon out more water as the media will displace the water inside the tank. Pay close attention to media level when filling (see diagram).

Do not overfill. The additional media added should not be higher than two-thirds of the tank height when measuring from the bottom (see diagram). Once the right height has been achieved, replace top fill plug. Grease "O" ring if necessary using only silicone grease.

Do not use petroleum based grease such as Vaseline. Tighten appropriately.

5. Leaving controller in the bypass position, turn on water source and refer to the start-up instructions of the controller and complete the procedure.
6. Once start up is complete, please check the top fill plug for any leaking.

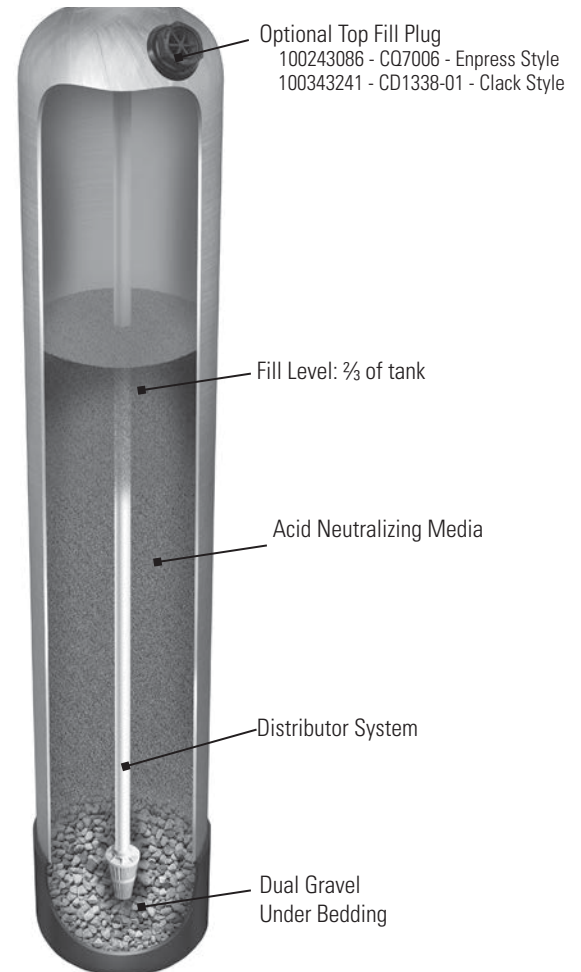

This page intentionally left blank.

TROUBLESHOOTING GUIDE

PROBLEM	CAUSE	CORRECTION
1. No display on PC board.	A. Depleted battery.	A. See Operating Display and Maintenance section.
	B. Control valve power adapter not plugged into outlet or power cord end not connected to PC board connection.	B. Plug power adapter into outlet or connect power cord end to PC board connection.
	C. Improper power supply.	C. Verify proper voltage is being delivered to PC board.
	D. Defective power adapter.	D. Replace power adapter.
	E. Defective PC board.	E. Replace PC board.
	F. No power at electric outlet.	F. Repair outlet or use working outlet.
2. PC board does not display correct time of day.	A. Power adapter plugged into electric outlet controlled by light switch.	A. Use uninterrupted outlet.
	B. Tripped breaker switch and/or tripped GFI.	B. Reset breaker switch and/or GFI switch.
	C. Power outage.	C. Reset time of day. If PC board has battery back up present the battery may be depleted. See front cover and drive assembly drawing for instructions.
	D. Defective PC board.	D. Replace PC board.
3. Display does not indicate that water is flowing. Refer to user instructions for how the display indicates water is flowing.	A. Bypass valve in bypass position.	A. Turn bypass handles to place bypass in service position.
	B. Meter is not connected to meter connection on PC board.	B. Connect meter to three pin connection labeled METER on PC board.
	C. Restricted/stalled meter turbine.	C. Remove meter and check for rotation or foreign material.
	D. Meter wire not installed securely into three pin connector.	D. Verify meter cable wires are installed securely into three pin connector labeled METER.
	E. Defective meter.	E. Replace meter.
	F. Defective PC board.	F. Replace PC board.
4. Control valve regenerates at wrong time of day.	A. Power outage.	A. Reset time of day. If PC board has battery back up present the battery may be depleted. See front cover and drive assembly drawing for instructions.
	B. Time of day not set correctly.	B. Reset to correct time of day.
	C. Time of regeneration set incorrectly.	C. Reset regeneration time.
	D. Control valve set at immediate regeneration.	D. Check programming setting and reset to DELAYED (for a delayed regen time).
5. Time of day flashes on and off.	A. Power outage.	A. Reset time of day. If PC board has battery back up present the battery may be depleted. See front cover and drive assembly drawing for instructions.
6. Control valve does not regenerate automatically when the correct button(s) is pressed and held. For timeclock valves the buttons are + or -. For all other valves the button is REGEN.	A. Broken drive gear or drive cap assembly.	A. Replace drive gear or drive cap assembly.
	B. Broken piston rod.	B. Replace piston rod.
	C. Defective PC board.	C. Defective PC board.
	D. Cover installed incorrectly.	D. Reinstall cover.

TROUBLESHOOTING GUIDE

PROBLEM	CAUSE	CORRECTION
7. Control valve does not regenerate automatically but does when the correct button(s) is depressed and held. For timeclock valves the buttons are + or -. For all other valves the button is REGEN.	A. Bypass valve in bypass position.	A. Turn bypass handles to place bypass in service position.
	B. Meter is not connected to meter connection on PC board.	B. Connect meter to three pin connection labeled METER on PC board.
	C. Restricted/stalled meter turbine.	C. Remove meter and check for rotation or foreign material.
	D. Incorrect programming.	D. Check for programming error.
	E. Meter wire not installed securely into three pin connector.	E. Verify meter cable wires are installed securely into three pin connector labeled METER.
	F. Defective meter.	F. Replace meter.
	G. Defective PC board.	G. Replace PC board.
8. Hard or untreated water is being delivered.	A. Bypass valve is open or faulty.	A. Fully close bypass valve or replace.
	B. Media is exhausted due to high water usage.	B. Check program settings or diagnostics for abnormal water usage.
	C. Meter not registering.	C. Remove meter and check for rotation or foreign material.
	D. Water quality fluctuation.	D. Test water and adjust program values accordingly.
	E. No regenerant or low level of regenerant in regenerant tank.	E. Add proper regenerant to tank.
	F. Control fails to draw in regenerant.	F. Refer to Troubleshooting Guide number 12.
	G. Insufficient regenerant level in regenerant tank.	G. Check refill setting in programming. Check refill flow control for restrictions or debris and, if necessary, replace.
	H. Damaged seal/stack assembly/piston.	H. Replace seal/stack assembly and/or piston.
	I. Control valve body type and piston type mix matched.	I. Verify proper control valve body type and piston type match.
	J. Fouled media bed.	J. Replace media bed.
9. Control valve uses too much regenerant.	A. Improper refill setting.	A. Check refill setting.
	B. Improper program settings.	B. Check program setting to make sure they are specific to the water quality and application needs.
	C. Control valve regenerates frequently.	C. Check for leaking fixtures that may be exhausting capacity or system is undersized.
10. Residual regenerant being delivered to service.	A. Low water pressure.	A. Check incoming water pressure – water pressure must remain at minimum of 25 psi.
	B. Incorrect, damaged, or restricted injector.	B. Replace injector with correct size for the application.
	C. Restricted drain line.	C. Check drain line for restrictions or debris and remove any obstructions.
11. Excessive water in regenerant tank.	A. Improper program settings.	A. Check refill setting.
	B. Plugged injector.	B. Remove injector and replace.
	C. Drive cap assembly not tightened in properly.	C. Re-tighten the drive cap assembly.
	D. Damaged seal/stack assembly/piston.	D. Replace seal/stack assembly and/or piston.
	E. Restricted or kinked drain line.	E. Check drain line for restrictions or debris and or unkink drain line.
	F. Plugged backwash flow controller.	F. Remove backwash flow controller and replace, if necessary.
	G. Missing refill flow controller.	G. Install refill flow controller.
	H. Brine tube not inserted properly into brine elbow in brine tank.	H. Install tube all the way into elbow.

TROUBLESHOOTING GUIDE

PROBLEM	CAUSE	CORRECTION
12. Control valve fails to draw in regenerant.	A. Injector is plugged.	A. Remove injector and replace.
	B. Faulty regenerant piston.	B. Replace regenerant piston.
	C. Regenerant line connection leak.	C. Inspect regenerant line for air leak.
	D. Drain line restriction or debris cause excess back pressure.	D. Inspect drain line and remove to correct restriction.
	E. Drain line too long or too high.	E. Shorten length and or height.
	F. Low water pressure.	F. Check incoming water pressure – water pressure must remain at minimum of 25 psi.
13. Water running to drain.	A. Power outage during regeneration.	A. Upon power being restored control will finish the remaining regeneration time. Reset time of day. If PC board has battery back up present the battery may be depleted. See front cover and drive assembly drawing for instructions.
	B. Damaged seal/stack assembly.	B. Replace seal/stack assembly.
	C. Piston assembly failure.	C. Replace piston assembly.
	D. Drive cap assembly not tightened in properly.	D. Re-tighten the drive cap assembly.
14. E1, Err – 1001, Err – 101 = Control unable to sense motor movement.	A. Motor not inserted full to engage pinion, motor wires broken or disconnected.	A. Disconnect power, make sure motor is fully engaged, check for broken wires, make sure two pin connector on motor is connected to the two pin connection on the PC board labeled MOTOR. Press NEXT and REGEN buttons for 3 seconds to resynchronize software with piston position or disconnect power supply from PC board for 5 seconds and then reconnect.
	B. PC board not properly snapped into drive bracket.	B. Properly snap PC board into drive bracket and then Press NEXT and REGEN buttons for 3 seconds to resynchronize software with piston position or disconnect power supply from PC board for 5 seconds and then reconnect.
	C. Missing drive gears.	C. Replace missing gears.
	D. Motor does not drive/run.	D. Replace motor.
	E. Viewing eye or encoder is blocked or damaged.	E. clear viewing eye on board, on drive bracket, or replace PC board if no debris is found.
15. E2, Err – 1002, Err – 102 = Excessive Motor Draw.	A. Foreign material is lodged in control valve.	A. Open up control valve and pull out piston assembly and seal/stack assembly for inspection. Press NEXT and REGEN buttons for 3 seconds to resynchronize software with piston position or disconnect power supply from PC board for 5 seconds and then reconnect.
	B. Mechanical binding.	B. Check piston and seal/stack assembly, check reduction gears, check drive bracket and main drive gear interface. Press NEXT and REGEN buttons for 3 seconds to resynchronize software with piston position or disconnect power supply from PC board for 5 seconds and then reconnect.
	C. Drive cap too loose.	C. Completely tighten drive cap assembly.
	D. Drive cap not “clicked” into backplate.	D. Verify that backplate is properly “clicked” into place.

TROUBLESHOOTING GUIDE

PROBLEM	CAUSE	CORRECTION
16. E3, Err – 1003, Err – 103 = Control valve motor ran too long and was unable to find the next cycle position.	A. Drive bracket not snapped in properly and out enough that reduction gears and drive gear do not interface.	A. Snap drive bracket in properly then Press NEXT and REGEN buttons for 3 seconds to resynchronize software with piston position or disconnect power supply from PC board for 5 seconds and then reconnect.
17. E4, Err – 1004, Err – 104 = Control valve motor ran too long and timed out trying to reach home position.	A. Drive bracket not snapped in properly and out enough that reduction gears and drive gear do not interface.	A. Snap drive bracket in properly then Press NEXT and REGEN buttons for 3 seconds to resynchronize software with piston position or disconnect power supply from PC board for 5 seconds and then reconnect.
	B. Piston not connected to drive cap.	B. Connect or replace (if damaged) piston/drive cap.
18. Err – 1006, Err – 106, Err – 116 = MAV/ SEPS/ NHBP/ AUX MAV valve motor ran too long and unable to find the proper park position. <ul style="list-style-type: none"> ● Motorized Alternating Valve = MAV ● Separate Source = SEPS ● No Hard Water Bypass = NHBP ● Auxiliary MAV = AUX MAV 	A. Control valve programmed for ALT A or B, nHbP, SEPS, or AUX MAV with out having a MAV or NHBP valve attached to operate that function.	A. Press NEXT and REGEN buttons for 3 seconds to resynchronize software with piston position or disconnect power supply from PC board for 5 seconds and then reconnect. Then reprogram valve to proper setting.
	B. MAV/NHBP motor wire not connected to PC board.	B. Connect MAV/NHBP motor to PC board two pin connection labeled DRIVE. Press NEXT and REGEN buttons for 3 seconds to resynchronize software with piston position or disconnect power supply from PC board for 5 seconds and then reconnect.
	C. MAV/NHBP motor not fully engaged with reduction gears.	C. Properly insert motor into casing, do not force into casing Press NEXT and REGEN buttons for 3 seconds to resynchronize software with piston position or disconnect power supply from PC board for 5 seconds and then reconnect.
	D. Foreign matter built up on piston and stack assemblies creating friction and drag enough to time out motor.	D. Replace piston and stack assemblies. Press NEXT and REGEN buttons for 3 seconds to resynchronize software with piston position or disconnect power supply from PC board for 5 seconds and then reconnect.
19. Err – 1007, Err – 107, Err – 117 = MAV/ SEPS/NHBP/ AUX MAV valve motor ran too short (stalled) while looking for proper park position. <ul style="list-style-type: none"> ● Motorized Alternating Valve = MAV ● Separate Source = SEPS ● No Hard Water Bypass = NHBP ● Auxiliary MAV = AUX MAV 	A. Foreign material is lodged in MAV/NHBP valve.	A. Open up MAV/NHBP valve and check piston and seal/ stack assembly for foreign material. Press NEXT and REGEN buttons for 3 seconds to resynchronize software with piston position or disconnect power supply from PC board for 5 seconds and then reconnect.
	B. Mechanical binding.	B. Check piston and seal/stack assembly, check reduction gears, drive gear interface, and check MAV/NHBP black drive pinion on motor for being jammed into motor body. Press NEXT and REGEN buttons for 3 seconds to resynchronize software with piston position or disconnect power supply from PC board for 5 seconds and then reconnect.

TROUBLESHOOTING GUIDE

PROBLEM	CAUSE	CORRECTION
20. Err – 201 200 errors are only viewable in history screens. These do not flash when error occurs.	A. Invalid regeneration cycle step detected.	A. Replace PC board.
21. Err – 202 200 errors are only viewable in history screens. These do not flash when error occurs.	A. Short power disruption.	A. Check transformer voltage and verify power source.
	B. Foreign material dislodged.	B. Check piston and stack for damage.
22. Err – 204 = Leak detected 200 errors are only viewable in history screens. These do not flash when error occurs.	A. Occurs when dP input is active for “ALARM” and the input is closed. The alarm buzzer will activate and the screen will display the error.	A. Check for low flow leak. Press NEXT and REGEN buttons for 3 seconds to resynchronize software with piston position or disconnect power supply from PC Board for 5 seconds and then reconnect to clear error.
23. Err – 400* Memory Errors *All 400 errors pertain to memory related errors. 400 and 200 errors are only viewable in history screens. These do not flash when error occurs.	A. Depleted Battery.	A. See Operating Display and Maintenance section.
	B. Defective PC Board.	B. Replace PC board.

REPLACEMENT PARTS

FRONT COVER AND DRIVE ASSEMBLY

Item #	Legacy Part #	Current Part #	Description	Qty.
1	CV4637-01	100379001	Valve cover	1
2	CV3107-1	100246273	Motor Assembly	1
3	CV3002-A	100246193	Drive assembly (includes #5 and #6)	—
4	CV4229XP-03	100243791	PC board	1
5	CV3110	100246279	Drive gear, 12 x 36	3
6	CV3109	100246278	Drive gear cover	1
not shown	CV3186-06	100249863	Transformer, 110V-12V, AC (standard)	1

NOTE: Battery Location

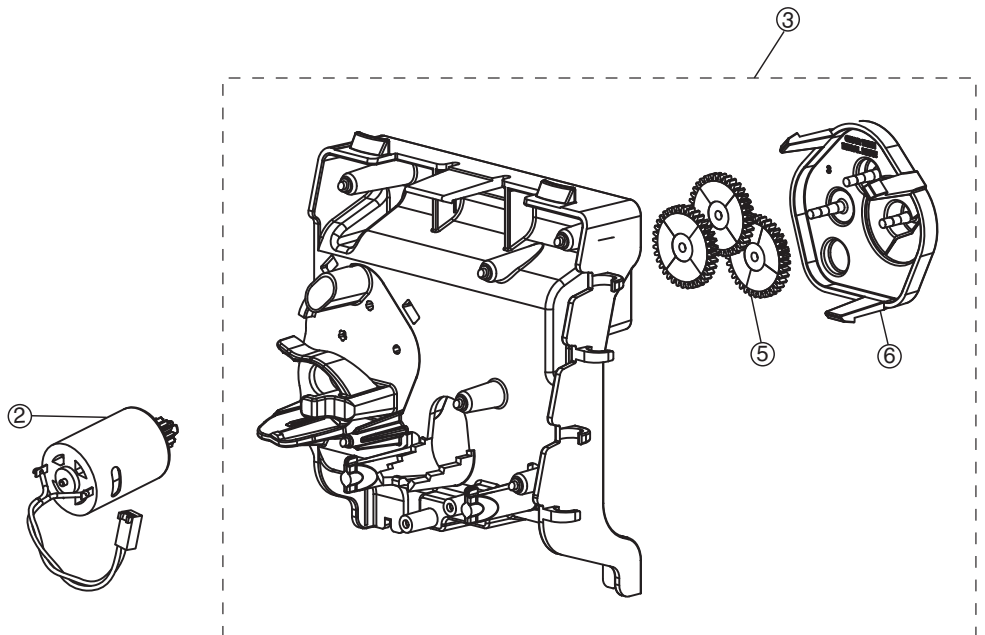
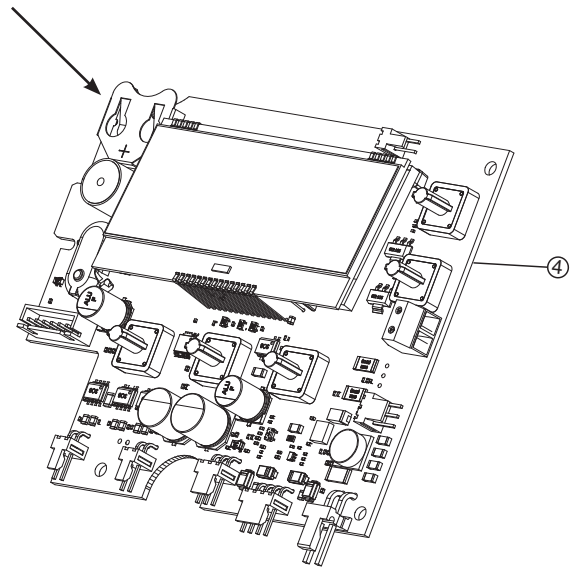
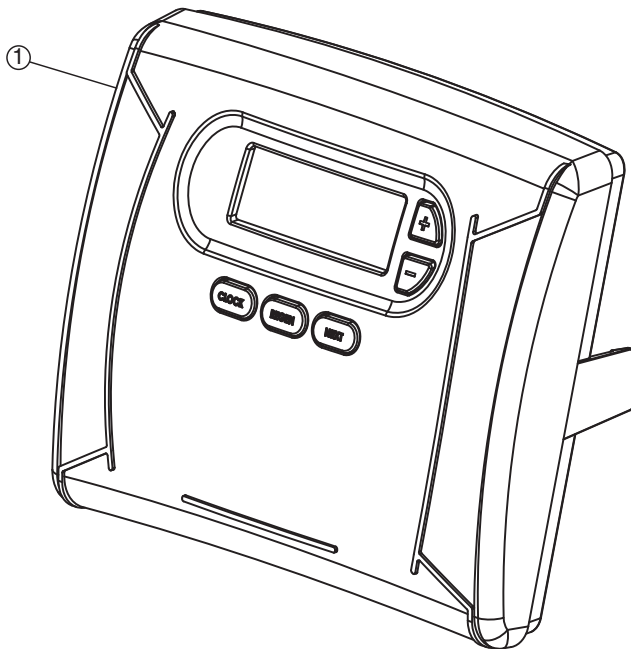

REPLACEMENT PARTS

PISTON ASSEMBLY

Item #	Legacy Part #	Current Part #	Description	Qty.
1	CV3005-02	100249844	1" spacer stack assembly	1
	CV3430-01	100249865	1.25" spacer stack assembly	1
2	CV3004	100246196	Drive cap assembly	1
3	CV3135	100246281	O-ring 228 (drive cap o-ring)	1
4	CV3011	100246232	1" piston assembly downflow	1
	CV3011-01	100246233	1" piston assembly upflow	1
	CV3407	100243924	1.25" piston assembly downflow	1
5	CV3174	100246296	Regenerant piston	1
6	CV3001-04	100244557	1" body assembly downflow	1
	CV3001-04UP	100243827	1" body assembly upflow	1
	CV3020	100246239	1.25" body assembly downflow	1
7	CV3541	100249867	Drive backplate	1
Not Shown	CD1225-05	100249834	Top basket softener (optional)	
	CD1249WR	100245766	Top basket filter	
	OV32 DN32	100248209	Internal check valve	

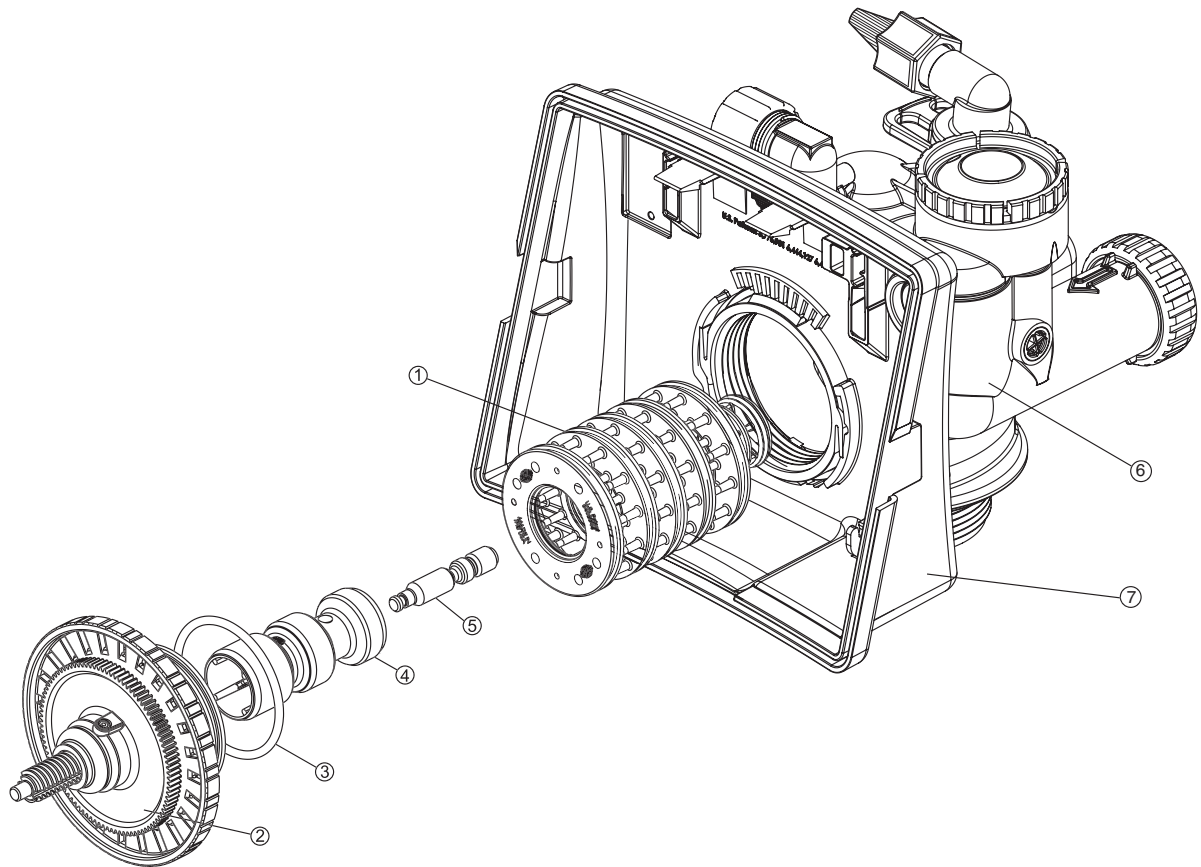

REPLACEMENT PARTS

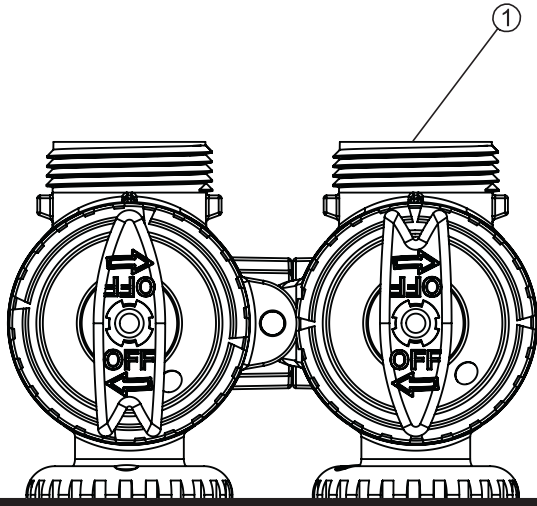

BYPASS VALVE

Item #.	Legacy Part #	Current Part #	Description	Qty.
1	CV3006	100249845	Bypass assembly	1
2	CV3147	100246284	Bypass handles	2

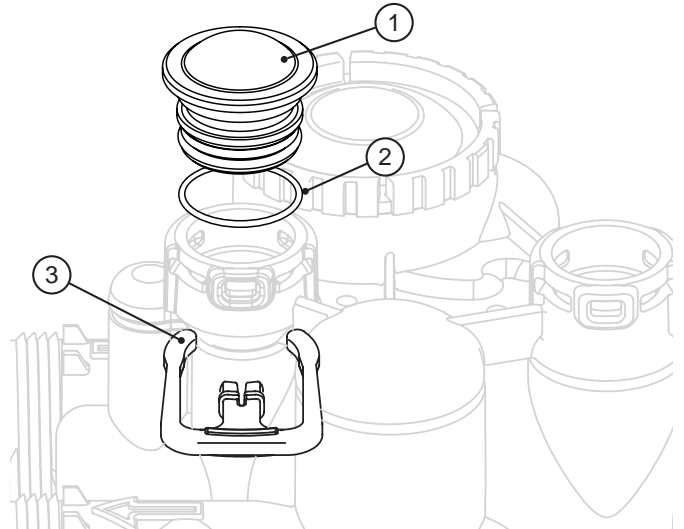

BRINE ELBOW ASSEMBLY

Item #	Legacy Part #	Current Part #	Description	Qty.
1	CV3195-01	100246323	Refill port plug assembly	1
2	CV3163	100246291	O-ring 019	1
3	CH4615	100245862	Elbow locking clip	1

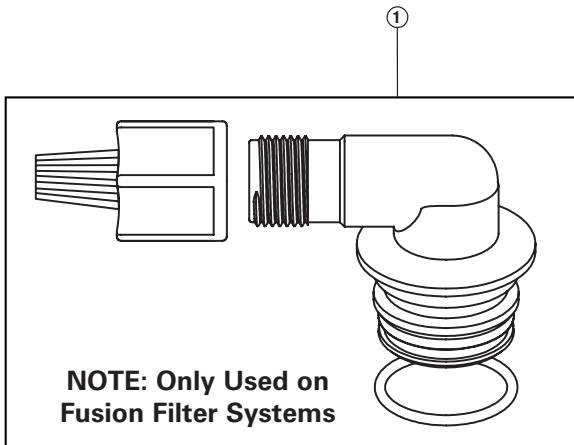

CHECK VALVE ASSEMBLY

Item #	Legacy Part #	Current Part #	Description	Qty.
1	CH4642-WR-A	100243963	Air check valve assembly	1

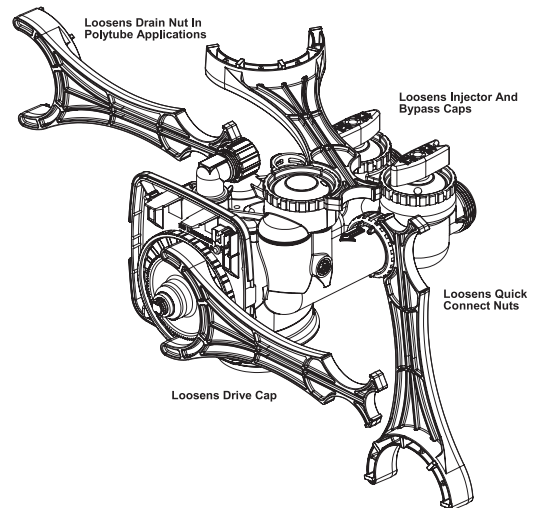

SERVICE WRENCH - 100249864 (CV3193-02)

Although no tools are necessary to assemble or disassemble the valve, the Service Wrench, (shown in various positions on the valve) is available to aid in assembly or disassembly.

REPLACEMENT PARTS

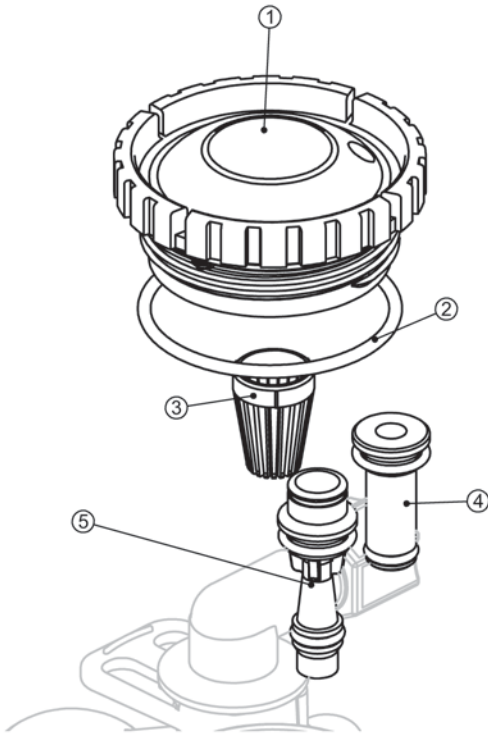

INJECTOR ASSEMBLIES

Item #	Legacy Part #	Current Part #	Description	Qty.
1	CV3176-01	100246304	Injector cap	1
2	CV3152	100244507	O-ring 135	1
3	CV3177-01	100246305	Injector screen	1
4	CV3010-1Z	100246221	Injector assembly plug	1
5	CV3010-1F	100246215	F injector assembly, BLUE	
	CV3010-1G	100246216	G injector assembly, YELLOW	

*The injector plug and the injector each use one lower and one upper O-ring.

WATER METER AND METER PLUG

Item #	Legacy Part #	Current Part #	Description	Qty.
1	CV3151	100246287	Nut, 1" Quick Connect	1
2	CV3003-05	100253284	Meter assembly	1
3	CV3003-01	100246195	Meter plug assembly	1

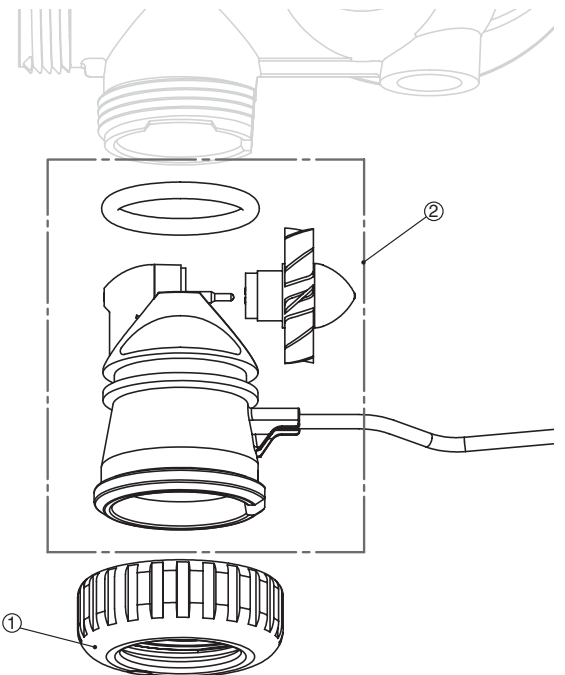
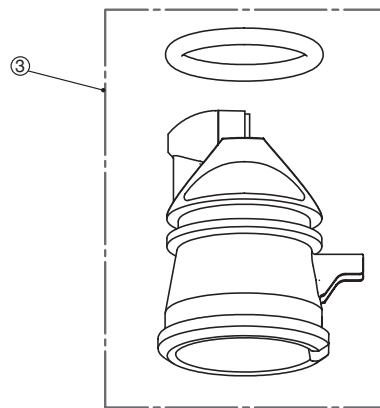

REPLACEMENT PARTS

DRAIN LINE ASSEMBLY 3/4"

Item #	Legacy Part #	Current Part #	Description	Qty.
1	CH4615	100245862	Elbow locking clip	1
2	CPKP10TS8-BULK	100245919	Optional insert, 5/8" tube	1
3	CV3192	100246322	Optional nut, 3/4" drain elbow	1
4	CV3158-02	100249851	Drain elbow, 3/4" NPT with O-ring, w/o silencer	1
5	CV3163	100246291	O-ring 019	1
6	CV3159-01	100246290	DLFC retainer assembly	1
7	CV3162-053	100249856	5.3 DLFC for 3/4" elbow	One DLFC must be used if 1" fitting is used
	CV3162-065	100249857	6.5 DLFC for 3/4" elbow	
	CV3162-075	100249858	7.5 DLFC for 3/4" elbow	
8	CV3331A	100245051	Drain elbow and retainer assembly (requires DLFC)	1

Items 2 and 3, nut and insert are only used with 1/2" I.D. by 5/8" O.D. polytubing. For other piping material, the 3/4" NPT is used.

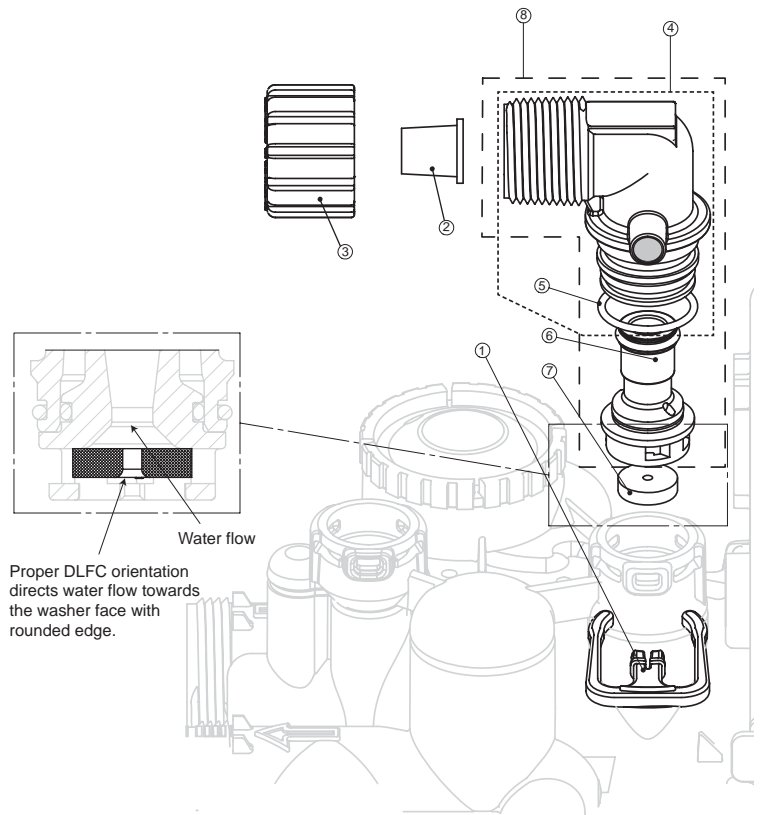

DRAIN LINE ASSEMBLY 1"

Item #	Legacy Part #	Current Part #	Description	Qty.
1	CH4615	100245862	Elbow locking clip	1
2	CV3166	100246292	Drain FTG body 1	1
	CV3166-01	100246293	FTG flow control body 1	
3	CV3163	100246291	O-ring 019	1
4	CV3150	100246286	Split ring	1
5	CV3151	100246287	Nut 1" QC	1
6	CV3105	100246272	O-ring 215	
7	CV3190-090	100246313	9.0 gpm DLFC for 1" elbow	One DLFC must be used if 1" fitting is used
	CV3190-100	100246314	10.0 gpm DLFC for 1" elbow	
	CV3190-110	100246315	11.0 gpm DLFC for 1" elbow	
	CV3190-130	100246316	13.0 gpm DLFC for 1" elbow	
	CV3190-150	100246317	15.0 gpm DLFC for 1" elbow	
	CV3190-170	100246318	17.0 gpm DLFC for 1" elbow	
	CV3190-200	100246319	20.0 gpm DLFC for 1" elbow	
CV3190-250	100246320	25.0 gpm DLFC for 1" elbow		
8	CV3008-04	100243824	FTG Drain 1" Strt No/Silencer (Requires DLFC)	1

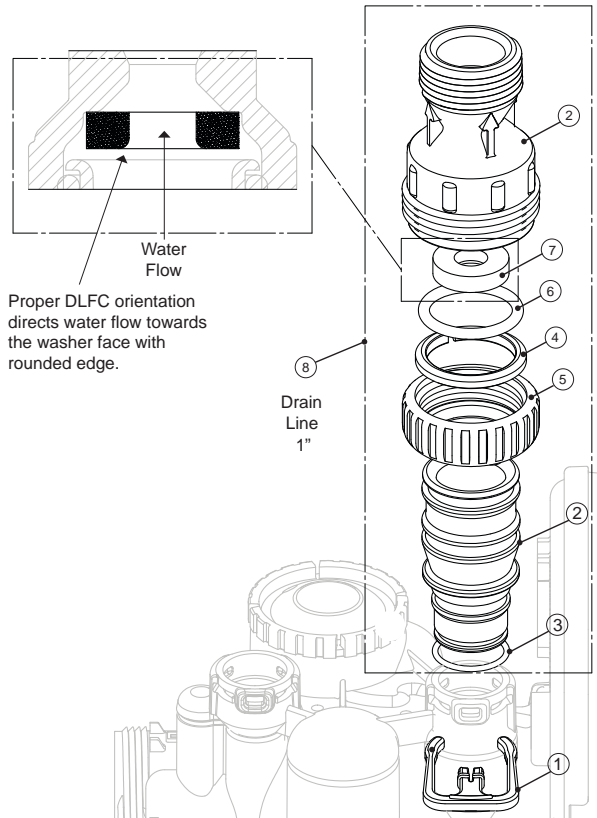

REPLACEMENT PARTS

IN/OUT HEAD

Item #	Legacy Part #	Current Part #	Description	Qty.
	CD1400	100245769	1191 In/Out Head	1
Not Shown	CV3180	100246307	Base O-Ring	1
	CV3105	100246272	Distributor Pilot O-Ring 215	1

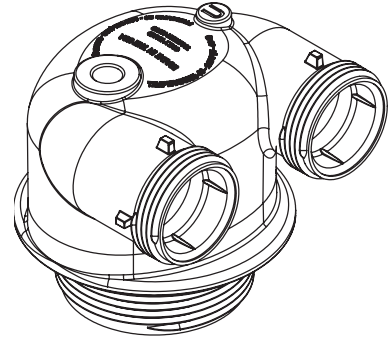

IN/OUT HEAD W/FILL PORT

Item #	Legacy Part #	Current Part #	Description	Qty.
	CD1220-01	100245758	1190 In/Out Head W/Port	1
Not Shown	CV3180	100246307	Base O-Ring	1
	CV3105	100246272	Distributor Pilot O-Ring 215	1
	CV3135	100246281	O-Ring, Fill Cap	1

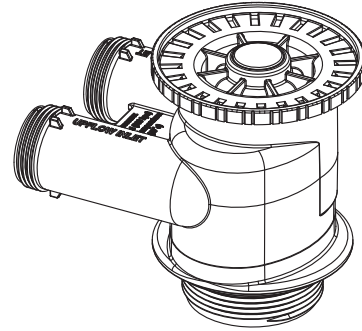

DOME HOLE PLUG

Item #	Legacy Part #	Current Part #	Description	Qty.
	CQ7006	100243086	Enpress Style Plug	1
	CD1338-01	100343241	Clack Style Plug	1

Both Style Plugs Include O-Ring

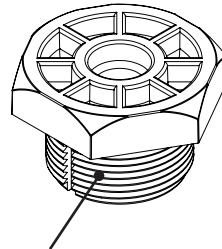

ENPRESS VERSION

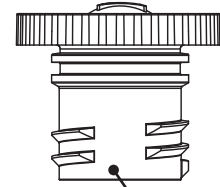

CLACK VERSION



OZONE GENERATOR

Item #	Legacy Part #	Current Part #	Description	Qty.
1	OZ1-A-99	100349795	Ozone Kit Assembly with No Replacement Board	1
1	OZ1-CASE	100174201	Enclosure Top, Bottom, and Clip	1
2	OZ33217-WRP3	100343535	Replacement Cell	1
3	CH4642-WR-A	100243963	Air Draw Elbow/Check Valve (includes part #4)	1
4	CJCPG-6PBLK	100245902	3/8" Compression Nut	1
5	CJCP-P-4	100245904	1/4" Polypropylene Insert	1



INSTALLATION FITTING ASSEMBLIES

NOTE: Not all available fittings are displayed below. Contact manufacturer for optional fittings.

For All Assemblies

Item #	Legacy Part #	Current Part #	Description	Qty.
1	CV3151	100246287	Nut, 1" quick connect	2
2	CV3150	100246286	Split ring	2
3	CV3105	100246272	O-ring 215	2

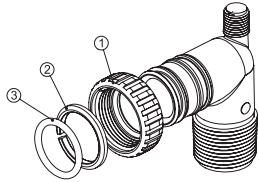

Legacy Part #	Current Part #	Description	Qty.
CV3007	100246197	1" PVC male NPT elbow assembly	2

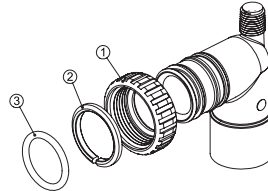

Legacy Part #	Current Part #	Description	Qty.
CV3007-01	100246198	3/4" & 1" PVC solvent elbow assembly	2

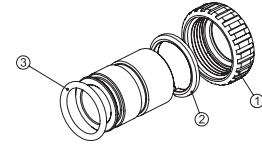

Legacy Part #	Current Part #	Description	Qty.
CV3007-02	100246199	1" brass sweat assembly	2

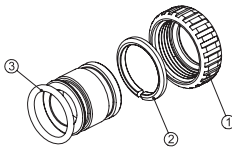

Legacy Part #	Current Part #	Description	Qty.
CV3007-03	100249846	3/4" brass sweat assembly	2

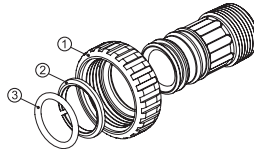

Legacy Part #	Current Part #	Description	Qty.
CV3007-04	100244506	1" plastic male NPT assembly	2

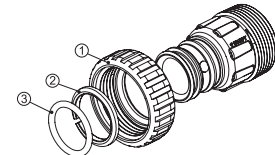

Legacy Part #	Current Part #	Description	Qty.
CV3007-05	100243921	1-1/4" plastic male assembly	2

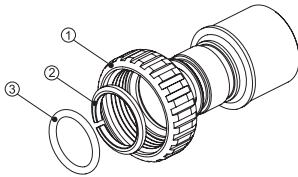

Legacy Part #	Current Part #	Description	Qty.
CV3007-09	100243922	1-1/4" & 1-1/2" brass sweat assembly	2

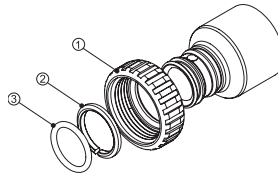

Legacy Part #	Current Part #	Description	Qty.
CV3007-07	100243375	1-1/4" & 1-1/2" PVC solvent assembly	2

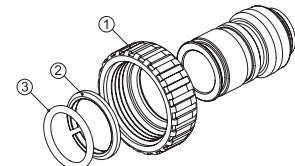

Legacy Part #	Current Part #	Description	Qty.
CV3007-12	100249847	3/4" brass shark bite assembly	2

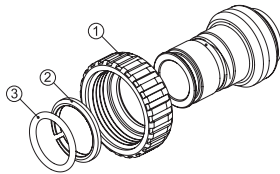

Legacy Part #	Current Part #	Description	Qty.
CV3007-13	100249848	1" brass shark bite assembly	2

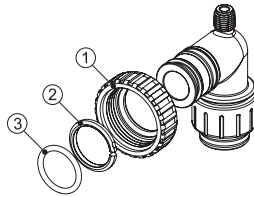

Legacy Part #	Current Part #	Description	Qty.
CV3007-15	100246200	3/4" john guest elbow assembly	2

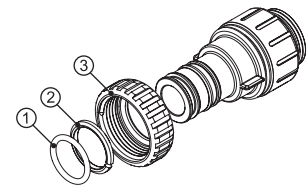

Legacy Part #	Current Part #	Description	Qty.
CV3007-17	100245045	1" john guest assembly	2

This page intentionally left blank.

FILTER SPECIFICATIONS

Backwashing/Acid Neutralizing Filters

MODEL	APBF-1054	APBF-1054	APBF-1054
Mineral Type	Carbon	Turbidex	Calcite or Mix
Amount (Cu. Ft.)	1.5	1.5	1.5
Continuous Flow (GPM)	5.0	7.0	4.8
Peak Flow (GPM)	9.0	11.0	11.0
Backwash Flow (GPM)	5.3	9.0	5.3
Total Dimensions	10"W x 62"H	10"W x 62"H	10"W x 62"H
Weight:			
Unfilled/Media (Lbs)	66/50	66/75	66/135

Air Filter

MODEL	APIS-1054
Mineral Type	Catalytic Carbon
Amount (Cu. Ft.)	1.0
Service Flow (GPM)	5.0
¹ Peak Flow (GPM)	8.0
Backwash Flow (GPM)	5.3
² Hydrogen Sulfide/Iron Reduction	5.0
pH Range	Greater than 7.0
Total Dimensions	10"W x 62"H
Weight Filled (Lbs.)	99

¹ Not tested at peak flow rate. Water quality will vary.

² Hydrogen Sulfide and Iron reduction may vary depending on local conditions. A maximum combined total of Hydrogen Sulfide and Iron must be 5.0ppm or less.

Cycle Times & Usage

MODEL	APBF-1054	
	MIN.	GAL.
Backwash	5	27
Rapid Rinse	1	5
Backwash	5	27
Rapid Rinse	4	21
Total	15	80

MODEL	APIS-1054	
	MIN.	GAL.
Backwash Air	4	16
Backwash	10	50
Regenerant Draw	60	25
Total	74	91

MODEL	APBF-1054 CARBON		APBF-1054 TURBIDEX		APBF-1054 CALCITE OR MIX	
	MIN.	GAL.	MIN.	GAL.	MIN.	GAL.
Backwash	5	27	5	45	5	27
Rinse	1	5	1	9	1	5
Backwash	5	27	5	45	5	27
Rinse	4	21	4	36	4	21

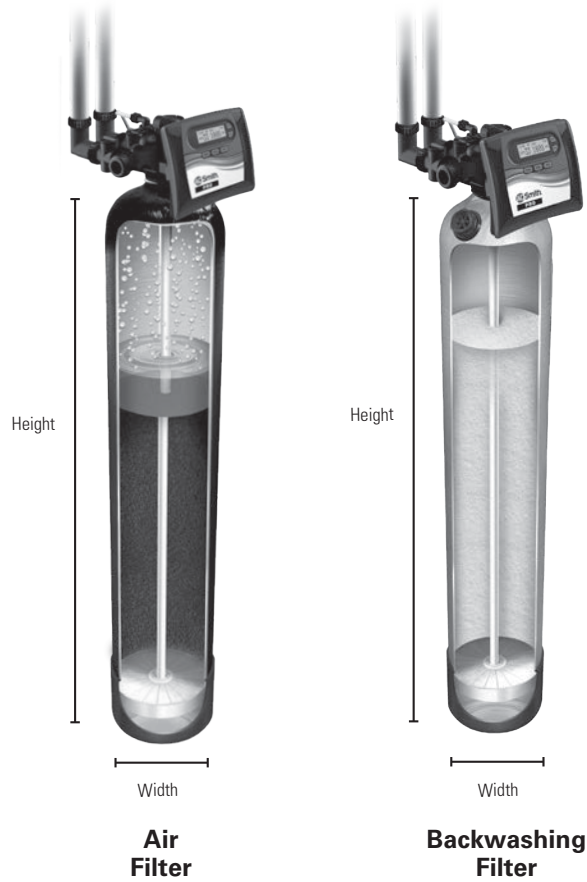



PRO

Water Filter Limited Warranty

Congratulations. You have purchased one of the finest water treatment systems available. In the unlikely event of a problem due to defects in material and workmanship, we proudly warrant our water filters to the original owner, when installed in accordance with A. O. Smith® specifications. This warranty is effective from the date of original installation for:

A period of TEN YEARS: **Fiberglass mineral tanks 13” and smaller; except for damages due to freezing, high pressure (120 PSI and above), extreme temperature (100°F and above) or a vacuum on the system.**

A period of FIVE YEARS: **Valve Body and PC Board.
Fiberglass mineral tanks 14” and larger.**

A period of ONE YEAR: **All other filter components.**

Any part found defective within the terms of this warranty will be repaired or replaced by the dealer. You pay only freight from our factory and local dealer charges. To obtain local warranty service, contact original dealer or an authorized service dealer. If no authorized dealer is located in your area, please ship defective part or component freight prepaid to A. O. Smith, 1900 Prospect Ct., Appleton, Wisconsin 54914. A. O. Smith, at its discretion, will repair or replace the part or component at its expense and return part freight collect.

The above provisions of the warranty are valid as long as the unit is connected in compliance with local plumbing codes and in an equivalent manner and condition of the original installation and is owned by the original owner.

This warranty does not cover damages due to accident, fire, flood, freezing, or any other Act of God. We are not responsible for damages due to change in water conditions, misapplication, misuse, neglect, vacuum, oxidizing agents, alteration, or lack of maintenance. No responsibility is assumed for loss of use of the unit, inconvenience, loss or damage to real or personal property or any incidental or consequential damages. Furthermore, we assume no liability and extend no warranties, express or implied, for the use of this product with a non-potable water source. **To the extent permitted by law, A. O. Smith disclaims all implied warranties, including without limitation warranties of merchantability and fitness for particular purpose; to the extent required by law, any such implied warranties are limited in duration to the aforementioned period specified above.**

Some states do not allow the exclusion of implied warranties or limitations on how long an implied warranty lasts. Consequently, the above limitation may not apply to you.

This warranty gives you specific legal rights, and you may also have other rights which vary from state to state.

QUICK REFERENCE GUIDE

GENERAL OPERATION

When the system is operating, one of four displays will be shown:

1. Time of day/gpm
2. Flow rate
3. Capacity remaining
4. Days to a regen
5. Dealer name and phone number

Pressing **NEXT** will toggle between the four choices.

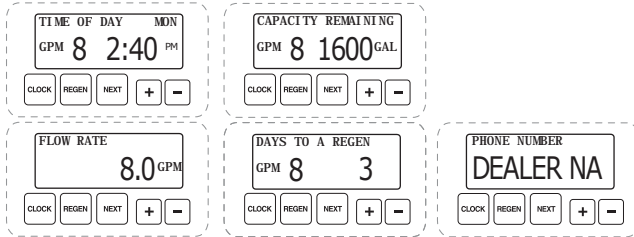

TO SET TIME OF DAY

In the event of a prolonged power outage, time of day flashes, indicating that this needs to be reset. All other information will be stored in memory no matter how long the power outage.

1. Accessed by pressing **CLOCK**
2. Adjust hours with + or — buttons, AM/PM toggles at 12
3. Press **NEXT**
4. Adjust minutes with + or — buttons
5. Press **NEXT**
6. Adjust current day with + or — buttons
7. Press **NEXT** to complete and return to normal operation

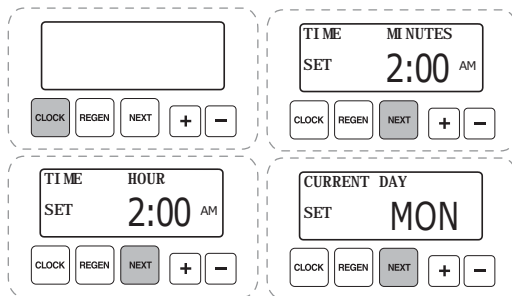

MANUAL REGENERATION

NOTE: If you need to initiate a manual regeneration, either immediately, or the same night at the pre-programmed time for regeneration (typically 2:00 AM), complete the following steps.

For Immediate Regeneration:

Press and hold **REGEN** until valve motor starts (typically 3 seconds).

For Regeneration the same night:

Press and release **REGEN** (notice that flashing “REGEN TODAY” appears).

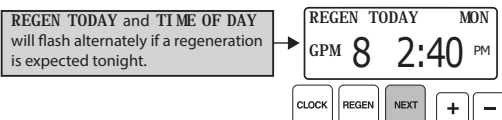

ERROR

If the display toggles between “Error” and an error code (i.e. a number), call a service technician and report the error code.

CALL FOR SERVICE
ERROR 106

BYPASS VALVE OPERATION

To shut off water to the system, position arrow handles as shown in the bypass operation diagram below. If your valve doesn't look like the diagram below, contact your service technician for instructions on how to shut off water.

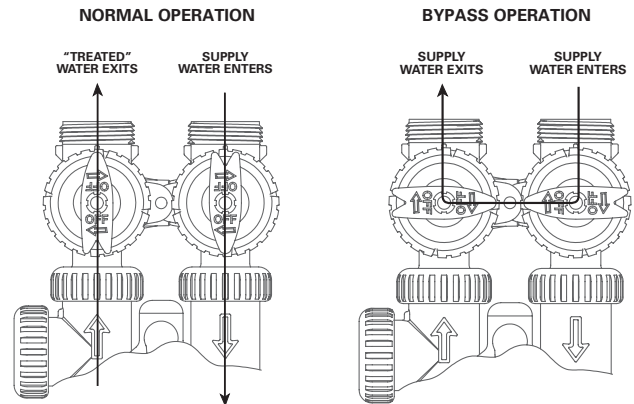

ADJUST DAYS BETWEEN REGENERATION, AND TIME OF REGENERATION

For initial set-up or to make adjustments, please complete the following steps.

1. Accessed by pressing **NEXT** and + button simultaneously
2. Press **NEXT**
3. Adjust days between regenerations using + or — buttons
4. Press **NEXT**
5. Adjust time of regeneration hour with + or — buttons, AM/PM toggles at 12.
6. Press **NEXT**
7. Adjust time of regeneration minutes with + or — buttons
8. Press **NEXT**
9. Turn display backlight ON or OFF with + or — buttons. Default is ON.
10. Press **NEXT** to complete and return to normal operation.

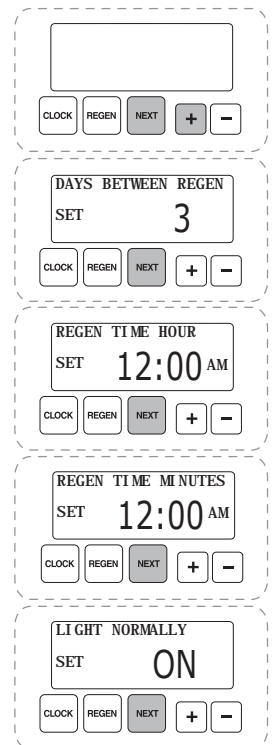

This page intentionally left blank.

This page intentionally left blank.



PRO

1900 Prospect Court, Appleton, WI, 54914
aosmith.com/watertreatment

