

Operator's Manual

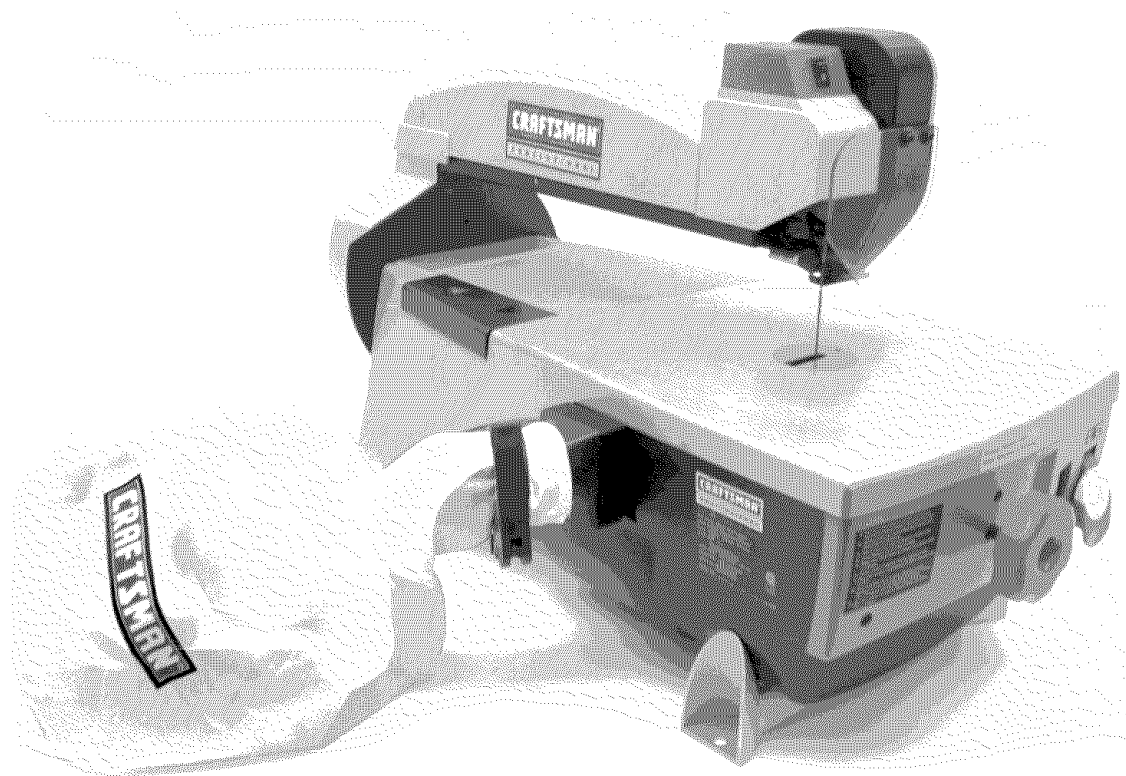

16" TILTING ARM SCROLL SAW WITH DUST COLLECTION

Model No.
351.224360



CAUTION: Read and follow all Safety Rules and Operating Instructions before First Use of this Product.

Sears, Roebuck and Co., Hoffman Estates, IL 60179 U.S.A.

www.sears.com/craftsman

21975.02 Draft (07/21/04)

TABLE OF CONTENTS

| | |
|-------------------------------|-------|
| Warranty | 2 |
| Safety Rules | 2-3 |
| Unpacking | 3 |
| Assembly | 3-4 |
| Installation | 4-5 |
| Operation | 5-8 |
| Maintenance | 8-9 |
| Troubleshooting | 10 |
| Parts Illustrations and Lists | 12-15 |

WARRANTY

FULL ONE YEAR WARRANTY

If this product fails due to a defect in material or workmanship within one year from the date of purchase, Sears will at its option repair or replace it free of charge. Contact your nearest Sears Service Center (1-800-4-MY-HOME) to arrange for product repair, or return this product to place of purchase for replacement.

If this product is used for commercial or rental purposes, this warranty will apply for 90 days from the date of purchase.

This warranty applies only while this product is used in the United States.

This warranty gives you specific legal rights and you may also have other rights which vary from state to state.

Sears, Roebuck and Co., Dept. 817WA, Hoffman Estates, IL 60179

SAFETY RULES

WARNING: For your own safety, read all of the instructions and precautions before operating tool.

CAUTION: Always follow proper operating procedures as defined in this manual — even if you are familiar with use of this or similar tools. Remember that being careless for even a fraction of a second can result in severe personal injury.

BE PREPARED FOR JOB

- Wear proper apparel. Do not wear loose clothing, gloves, neckties, rings, bracelets or other jewelry which may get caught in moving parts of machine.
- Wear protective hair covering to contain long hair.
- Wear safety shoes with non-slip soles.
- Wear safety glasses complying with United States ANSI Z87.1. Everyday glasses have only impact resistant lenses. They are **NOT** safety glasses.
- Wear face mask or dust mask if operation is dusty.

- Be alert and think clearly. Never operate power tools when tired, intoxicated or when taking medications that cause drowsiness.

PREPARE WORK AREA FOR JOB

- Keep work area clean. Cluttered work areas invite accidents.
- Do not use power tools in dangerous environments. Do not use power tools in damp or wet locations. Do not expose power tools to rain.
- Work area should be properly lighted.
- Proper electrical receptacle should be available for tool. Three-prong plug should be plugged directly into properly grounded, three-prong receptacle.
- Extension cords should have a grounding prong and the three wires of the extension cord should be of the correct gauge.
- Keep visitors at a safe distance from work area.
- Keep children out of workplace. Make workshop childproof. Use padlocks, master switches or remove switch keys to prevent any unintentional use of power tools.

TOOL SHOULD BE MAINTAINED

- Always unplug tool prior to inspection.
- Consult manual for specific maintaining and adjusting procedures.
- Keep tool lubricated and clean for safest operation.
- Remove adjusting tools. Form habit of checking to see that adjusting tools are removed before switching machine on.
- Keep all parts in working order. Check to determine that the guard or other parts will operate properly and perform their intended function.
- Check for damaged parts. Check for alignment of moving parts, binding, breakage, mounting and any other condition that may affect a tool's operation.
- A guard or other part that is damaged should be properly repaired or replaced. Do not perform makeshift repairs. (Use parts list provided to order replacement parts.)

KNOW HOW TO USE TOOL

- Use right tool for job. Do not force tool or attachment to do a job for which it was not designed.
- Disconnect tool when changing blade.
- Avoid accidental start-up. Make sure that the tool is in the OFF position before plugging in.
- Do not force tool. It will work most efficiently at the rate for which it was designed.
- Keep hands away from moving parts and cutting surfaces.
- Never leave tool running unattended. Turn the power off and do not leave tool until it comes to a complete stop.
- Do not overreach. Keep proper footing and balance.

- Never stand on tool. Serious injury could occur if tool is tipped or if blade is unintentionally contacted.
- Know your tool. Learn the tool's operation, application and specific limitations.
- Use recommended accessories (refer to page 15). Use of improper accessories may cause risk of injury to persons.
- Handle workpiece correctly. Protect hands from possible injury.
- Turn machine off if it jams. Blade jams when it digs too deeply into workpiece. (Motor force keeps it stuck in the work.) Do not remove jammed or cut off pieces until the saw is turned off, unplugged and the blade has stopped.

WARNING: The operation of any power tool can result in foreign objects being thrown into the eyes, which can result in severe eye damage. Always wear safety goggles complying with United States ANSI Z87.1 (shown on package) before commencing power tool operation. Safety goggles are available through your Sears catalog.

UNPACKING

Check for shipping damage. If damage has occurred, a claim must be filed with carrier. Check for completeness. Immediately report missing parts to dealer.

The scroll saw comes assembled as one unit. Additional parts which need to be fastened to the saw should be located and accounted for before assembling:

- A Scroll Saw
- B Dust Bag
- C Clamp
- D Dust Chute

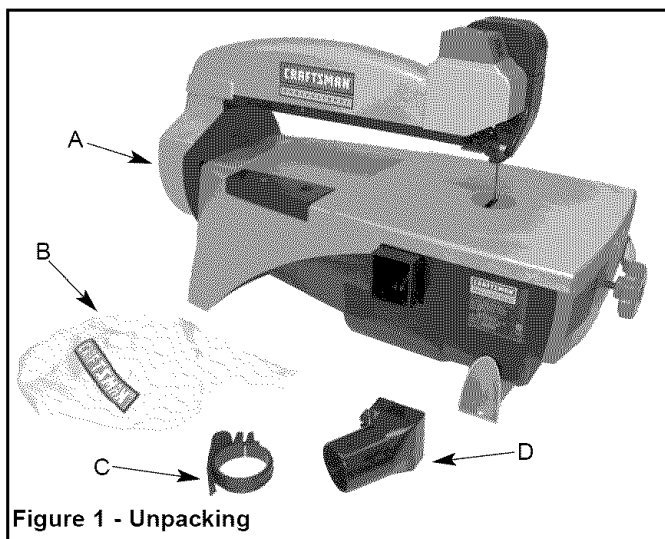

Figure 1 - Unpacking

IMPORTANT: Table is coated with a protectant. To ensure proper fit and operation, remove coating. Coating is easily removed with mild solvents, such as mineral spirits, and a soft cloth. Avoid getting solution on paint or any of the rubber or plastic parts. Solvents may deteriorate these finishes. Use soap and water on paint, plastic or rubber components. After cleaning, cover all exposed surfaces with a light coating of oil. Paste wax is recommended for table top.

WARNING: Never use highly volatile solvents. Non flammable solvents are recommended to avoid possible fire hazard.

ASSEMBLY

CAUTION: Do not attempt assembly if parts are missing. Use operator's manual to order replacement parts.

MOUNT SCROLL SAW TO WORK SURFACE

- Scroll saw should be mounted to stable, level bench or table. See Recommended Accessories, page 15.
- Base of band saw has four mounting holes (see Figure 2 for dimensions and required spaces).
- If predrilled holes do not exist on work surface, drill four holes.
- Securely mount band saw to work surface by bolting (hardware not supplied) it through the holes.

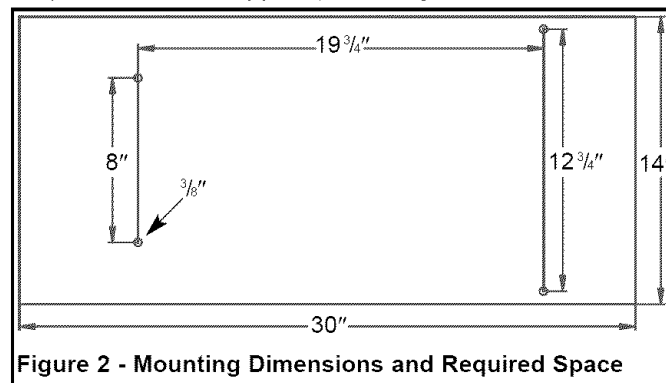

Figure 2 - Mounting Dimensions and Required Space

INSTALL DUST CHUTE

- Slide dust chute over fan housing. Secure in position with screw (see Figure 3).

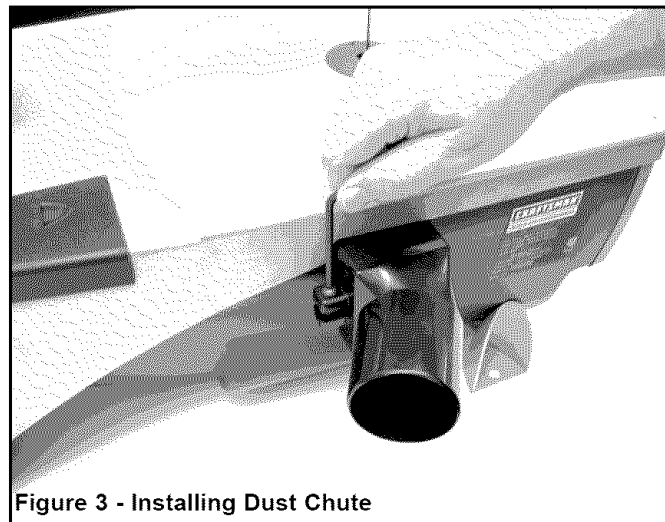

Figure 3 - Installing Dust Chute

INSTALL DUST COLLECTION BAG

Dust collection system consists of a 30-micron bag and clamp.

- Place clamp over bag sleeve (see Figure 4).
- Slide sleeve with clamp over dust chute. Rotate handle to increase clamp size.
- Secure in position by tightening clamp. **Do not force handle.**

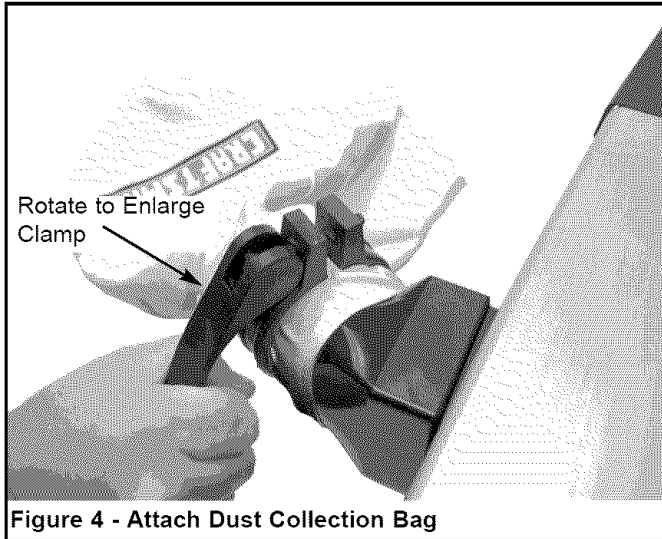

Figure 4 - Attach Dust Collection Bag

INSTALLATION

Refer to Figures 5, 6 and 7.

MOTOR

The 120 Volt AC motor has the following specifications:

| | |
|--|--------|
| Horsepower (Maximum Developed) | 2/5 |
| Voltage | 120 |
| Amps | 2.3 |
| Hertz | 60 |
| Phase | Single |
| RPM | 1725 |

POWER SOURCE

The motor is designed for operation on the voltage and frequency specified. Normal loads will be handled safely on voltages not more than 10% above or below the specified voltage.

Running the unit on voltages which are not within the range may cause overheating and motor burn-out. Heavy loads require that the voltage at motor terminals be no less than the voltage specified. Power supply to the motor is controlled by a single pole locking rocker switch. Remove the key to prevent unauthorized use.

GROUNDING INSTRUCTIONS

WARNING: Improper connection of equipment grounding conductor can result in the risk of electrical shock. Equipment should be grounded while in use to protect operator from electrical shock.

Check with a qualified electrician if grounding instructions are not understood or if in doubt as to whether the tool is properly grounded.

This tool is equipped with an approved 3 conductor cord rated at 150V and a three prong grounding type plug for your protection against shock hazards.

Grounding plug should be plugged directly into a properly installed and grounded 3-prong grounding-type receptacle, as shown (Figure 5).

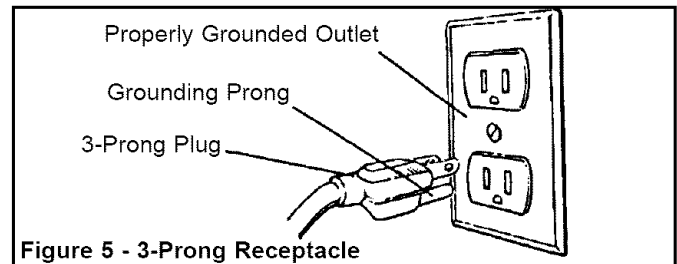

Figure 5 - 3-Prong Receptacle

Do not remove or alter grounding prong in any manner. In the event of a malfunction or breakdown, grounding provides a path of least resistance for electrical shock.

WARNING: Do not permit fingers to touch the terminals of plug when installing or removing from outlet.

Plug must be plugged into matching outlet that is properly installed and grounded in accordance with all local codes and ordinances. Do not modify plug provided. If it will not fit in outlet, have proper outlet installed by a qualified electrician.

Inspect tool cords periodically, and if damaged, have them repaired by an authorized service facility.

Green (or green and yellow) conductor in cord is the grounding wire. If repair or replacement of the electric cord or plug is necessary, do not connect the green (or green and yellow) wire to a live terminal.

Where a 2-prong wall receptacle is encountered, it must be replaced with a properly grounded 3-prong receptacle installed in accordance with National Electric Code and local codes and ordinances.

WARNING: This work should be performed by a qualified electrician.

A temporary 3-prong to 2-prong grounding adapter (see Figure 6) is available for connecting plugs to a two pole outlet if it is properly grounded.

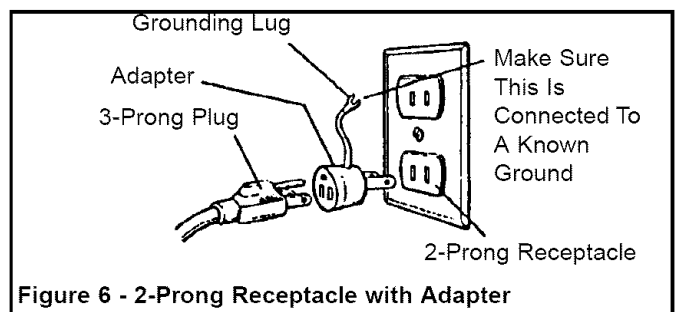

Figure 6 - 2-Prong Receptacle with Adapter

Do not use a 3-prong to 2-prong grounding adapter unless permitted by local and national codes and ordinances. (A 3-prong to 2-prong grounding adapter is not permitted in Canada.) Where permitted, the rigid green

tab or terminal on the side of the adapter must be securely connected to a permanent electrical ground such as a properly grounded water pipe, a properly grounded outlet box or a properly grounded wire system. Many cover plate screws, water pipes and outlet boxes are not properly grounded. To ensure proper ground, grounding means must be tested by a qualified electrician.

EXTENSION CORDS

- The use of any extension cord will cause some drop in voltage and loss of power.
- Wires of the extension cord must be of sufficient size to carry the current and maintain adequate voltage.
- Use the table to determine the minimum wire size (A.W.G.) extension cord.
- Use only 3-wire extension cords having 3-prong grounding type plugs and 3-pole receptacles which accept the tool plug.
- If the extension cord is worn, cut or damaged in any way, replace immediately.

EXTENSION CORD LENGTH

| Wire Size | A.W.G. |
|----------------------|--------|
| Up to 50 ft. | 16 |

NOTE: Using extension cords over 50 ft. long is not recommended.

ELECTRICAL CONNECTIONS

WARNING: All electrical connections must be performed by a qualified electrician. Make sure tool is off and disconnected from power source while motor is mounted, connected, reconnected or anytime wiring is inspected.

Motor and wires are installed as shown in wiring schematic (see Figure 7). Motor is assembled with approved, 3-conductor cord to be used at 120 volts.

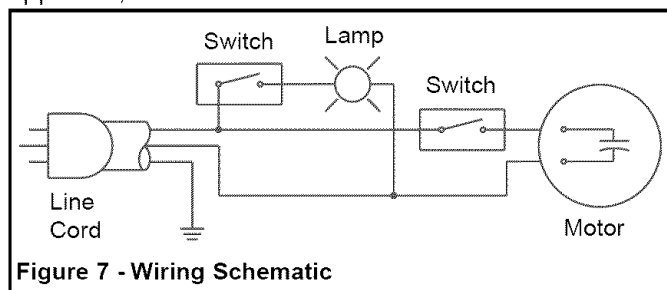

The green ground line must remain securely fastened to the frame to properly protect against electrical shock. The power supply to the motor is controlled by a single pole locking rocker switch.

- Remove the key to prevent unauthorized use.

OPERATION

Refer to Figures 8 - 16, pages 6-8.
The Craftsman 16" Tilting Arm Scroll Saw features aluminum frame construction, built-in dust collection and a

constant power mechanical variable speed control system. It is designed for cutting hard and soft woods, as well as nonferrous metals and plastics. Arm of the saw tilts from 90° to 45° while the table remains in horizontal position for straight line feeding of the material. The built-in motor driven, dust collection system helps to keep the workpiece clean from both above and below the worksurface. Sawdust is deposited into a detachable 30 micron filter bag for convenient disposal. A convenient quick tensioning mechanism makes blade changing quick and easy.

SPECIFICATIONS

| | |
|---|--------------------------------------|
| Depth of throat at 90° | 16 ³ / ₄ " |
| Maximum thickness of cut at 90° | 2" |
| Maximum thickness of cut at 45° | 1 ¹ / ₄ " |
| Table size | 12 ¹ / ₂ x 13" |
| Arm tilt | 90° to 45° |
| Blade length (pin type) | 5" |
| Blade speed (strokes/minute) | 300-1400 |
| Stroke length | ³ / ₄ " |
| Overall dimensions (D x W x H) | 30 x 14 x 18" |
| Weight | 76 lbs |
| Dust collection port | 2 ¹ / ₂ " |

SAFETY RULES FOR SCROLL SAWS

WARNING: For your own safety, read all of the instructions and precautions before operating tool.

WARNING: Operation of any power tool can result in foreign objects being thrown into eyes which can result in severe eye damage. Always wear safety goggles complying with United States ANSI 287.1 (shown on package) before commencing power tool operation.

CAUTION: Always observe the following safety precautions:

- Know general power tool safety. Make sure all precautions are understood (see pages 2-3).
- Make sure scroll saw is securely fastened to a workbench, worktable or stand.
- Use scroll saw indoors only.
- Make sure blade is properly installed before using saw.
- Make sure blade teeth point downward towards the table.
- Always keep hands and fingers away from blade.
- Never use dull or bent blades.
- Always adjust holddown properly for each workpiece.
- Always clear table of objects (tools; scrap pieces) before turning saw ON.
- Never cut material that is too small to be held safely.
- Always hold workpiece firmly on table.
- Always make sure that large workpieces are completely supported.
- Make sure that arm tilting handle is locked before using saw.



- Never start saw with workpieces pressed against the blade.
- Always stop saw before removing scrap pieces from the table.
- Use extra caution when cutting round workpieces and workpieces that have an irregular cross section.

OPERATING CONTROLS AND ADJUSTMENTS

Refer to Figure 8.

ON/OFF Switch

The ON/OFF switch is located on the right side of the front panel of the saw. To turn the saw ON, move the switch to the up position. To turn the saw OFF, move the switch to the down position.

Speed Control Knob

The speed control knob is located in the center of the front panel of the saw. To increase blade speed, rotate the knob counterclockwise. To decrease blade speed, rotate the knob clockwise.

CAUTION: Change speeds only while machine is running.

Speed Indicator

Indicates the blade speed in strokes per minute.

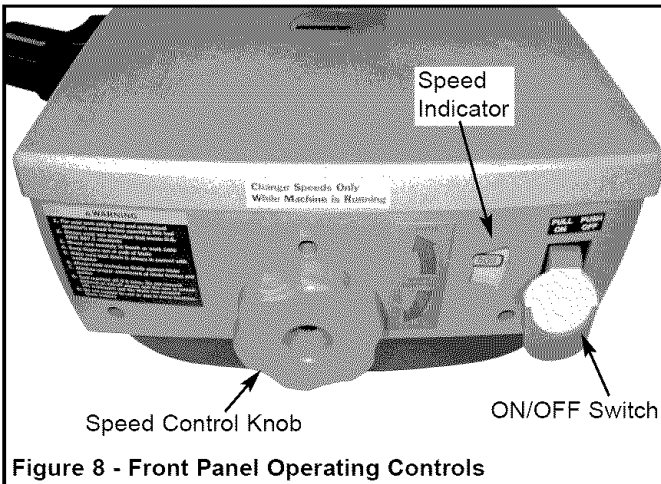

Switch Lock

Refer to Figure 9.

The saw can be locked from unauthorized use by locking the switch. To lock the switch:

- Turn the switch to OFF position and disconnect saw from power source.
- Pull the key out. The switch cannot be turned on with the key removed.

NOTE: Should the key be removed from the switch at the ON position, the switch can be turned off but cannot be turned on.

- To replace key, slide key into the slot on switch until it snaps.

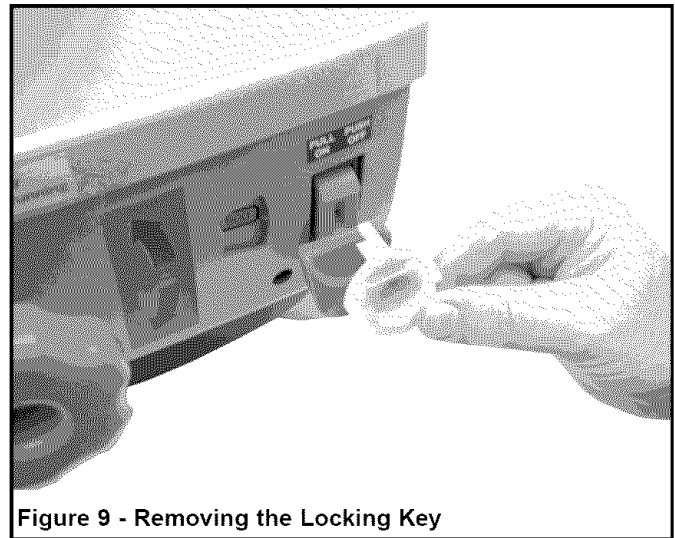

Work Light

Refer to Figure 10.

The worklight and worklight switch are located at the end of the saw arm.

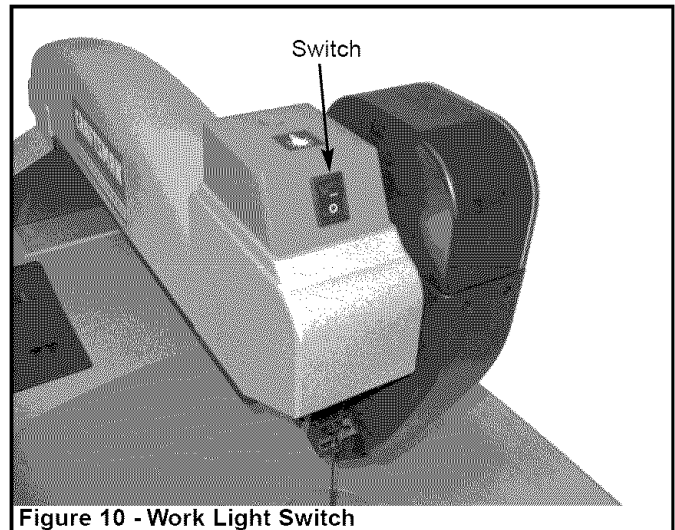

Tool Blade Storage

Refer to Figure 11.

Tools and extra blades can be stored in the toolbox located at the rear left side of the table.

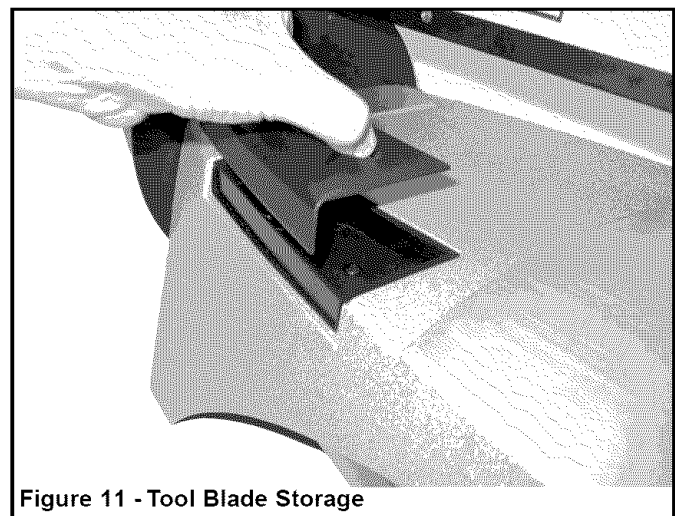

Tilting The Arm

Refer to Figure 12.

The arm of the scroll saw can be tilted from 0 to 45° to the left by loosening the arm locking handle counter-clockwise, tilting the arm to desired angle, and tightening the arm locking handle clockwise. Scale and pointer show the angle of tilt.

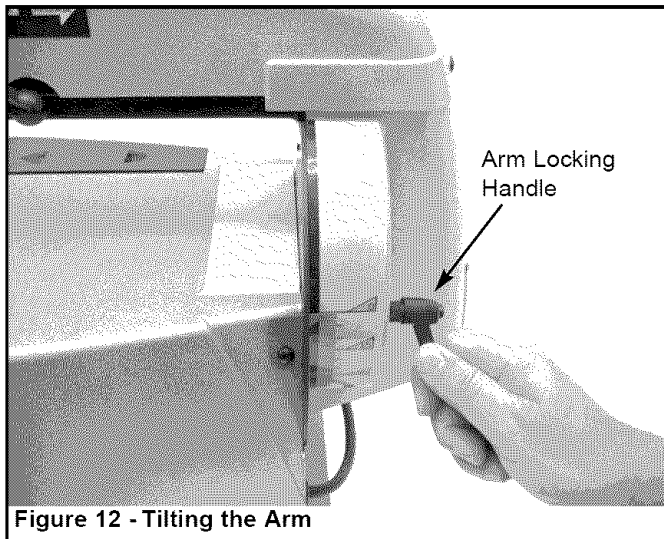

Figure 12 - Tilting the Arm

Holddown Assembly

Refer to Figure 13.

The holddown assembly is located at the right front of the arm. To adjust pull up on lever, reposition holddown foot to contact top of workpiece, and release lever. The assembly includes a clear plastic blade guard and nozzle for dust collection.

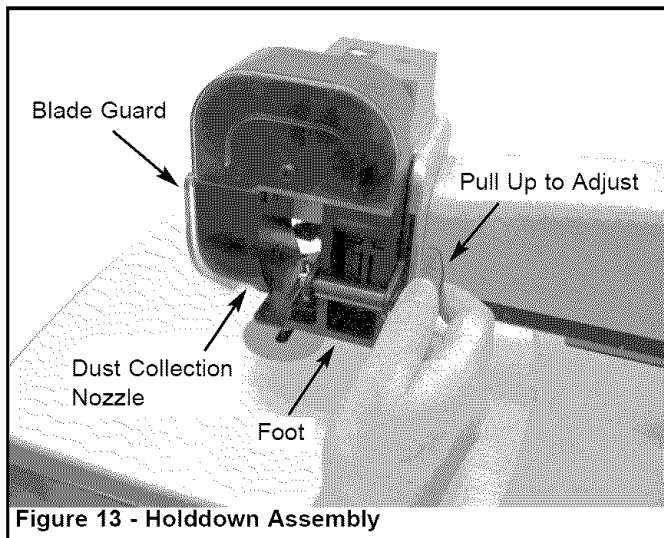

Figure 13 - Holddown Assembly

Blade Lock/Release Lever

Refer to Figure 14.

WARNING: To avoid injury from accidental starting, always turn switch OFF and remove power cord plug from electrical outlet before removing or replacing blade.

The blade/lock release lever is located on the middle right side of the arm and is used when changing blades. Lever rests in the "lock" position. Pushing lever back releases tension on the blade holders and blade can be installed or removed.

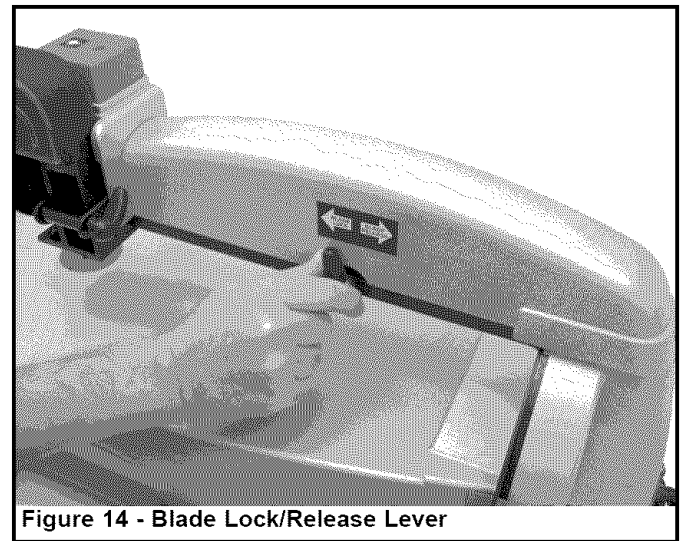

Figure 14 - Blade Lock/Release Lever

INSTALLING AND REMOVING BLADES

Refer to Figures 14, 15 and 16, pages 7 and 8.

WARNING: To avoid injury from accidental starting, always turn switch OFF and remove power cord plug from electrical outlet before removing or replacing blade.

- Remove table insert. Release blade tension by pushing lock/release lever backwards (see Figure 14).
- Carefully remove blade from upper and lower holders.
- Insert new blade into the lower holder first and then into the upper holder (see Figures 15 and 16).

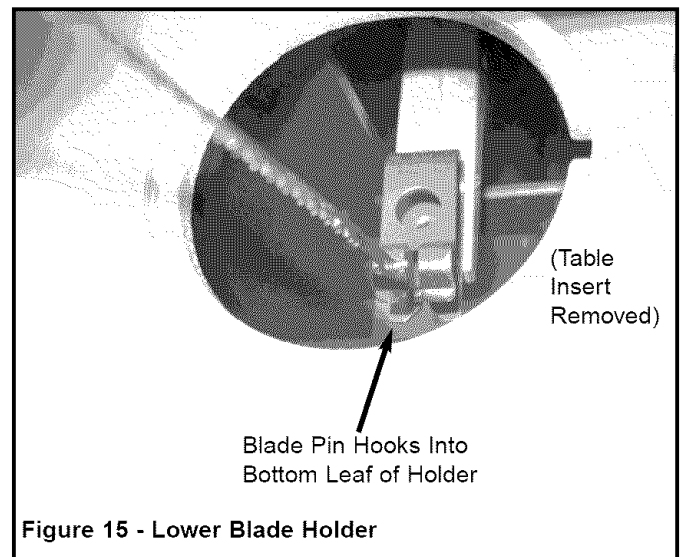

Figure 15 - Lower Blade Holder

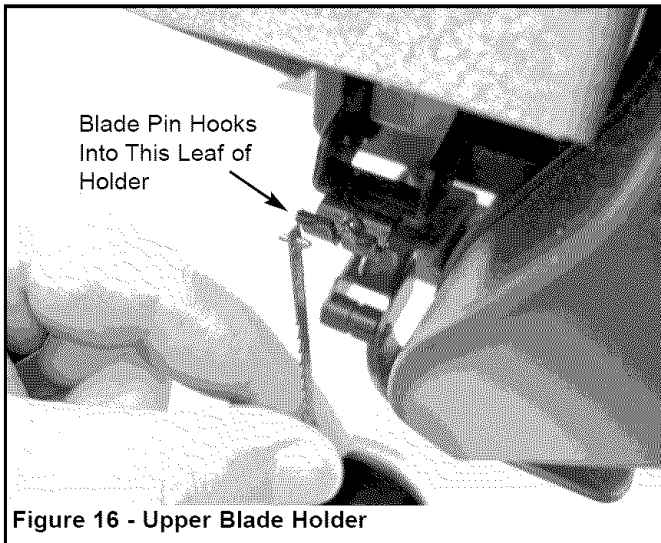

Figure 16 - Upper Blade Holder

- Release blade lock/release lever.
- Replace table insert.

FEED RATES

- Feeding at a slower rate produces a better surface finish.
- Do not try to feed workpiece faster than the blade can cut. This will cause blade breakage.

BLADE SPEEDS

- Most workpieces (hardwood and softwood thicker than 1/4") can be cut with speeds of 1000 to 1400 strokes/minute.
- Begin at a slower speed and gradually increase the speed to the above mentioned range.
- Use slower speeds for thin workpieces, intricate cuts and when using thin blades.

BLADE SELECTION

- Blades vary depending on type of material, size of workpiece and type of cut that is being performed.
- Characteristics which make blades different are width, thickness and pitch.

BLADE WIDTH

- Width of blade describes distance from tip of a tooth to back of blade.
- Width of blade will affect rigidity of blade. A wider blade will wander less and produce a straighter cut.
- Width of blade also limits the smallest radius which can be cut. A 1/4" wide blade can cut about a 1/2" radius.

BLADE THICKNESS

- Blade thickness describes the distance between sides of blade. A thicker blade has more rigidity and stronger teeth.

BLADE PITCH

- Pitch describes number of teeth per inch or tooth size. A blade with more teeth per inch will produce a smoother cut.

- Use a finer (more teeth/inch) blade for thin workpieces and hard materials.
- Use a coarser (less teeth/inch) blade for thick workpieces and softer materials.
- There should always be at least two teeth in contact with workpiece.
- Blade manufacturers are prepared to supply information about blades for specific applications.

TYPE OF CUT

- Contour cutting is done by guiding workpiece free-handed to produce curved shapes.
- Beveled cutting can be done by tilting saw arm and using proper work guide method.
- Regardless of which work guiding method is used, a workpiece which overhangs table by more than 5" should be properly supported

CONTOUR SAWING

- When contour sawing, use both hands to keep workpiece flat against table and guided along desired path.
- Avoid positioning hands in line with blade. If hands slip, they could contact blade.
- Cut small corners by sawing around them. Saw to remove scrap until desired shape is obtained.

BEVEL CUTTING

Refer to Figure 12, page 7.

- Perform bevel cutting by tilting head to desired degree.
- Unlock head by loosening locking handle located on the backside of the unit.
- Tilt head to desired position.
- Lock head in position by tightening locking handle.

MAINTENANCE

WARNING: Make certain that unit is disconnected from power source before attempting to service or remove any component.

CLEANING

- Keep machine and workshop clean. Do not allow sawdust to accumulate on scroll saw.
- Keep mechanisms and threaded or sliding surfaces clean and free of foreign particles.

LUBRICATION

- The shielded ball bearings are permanently lubricated and require no further lubrication.
- Small amounts of machine oil can be applied to belt pulley mechanism and threaded or sliding surfaces.
- Occasionally apply a coat of paste wax to table top to keep it slick and corrosion free.

KEEP SCROLL SAW IN REPAIR

- If power cord is worn or cut in any way, have it replaced.
- Replace any damaged or missing part.
- Use parts list to order parts.

REPLACING BELTS

Refer to Figures 17, 18 and 19..

- Remove screw, washer and speed control knob (Fig. 18, Key Nos. 1, 2 and 3).
- Remove three bolts from front panel (Fig. 18, Key Nos. 4 and 6).
- Carefully pull front panel out and slide dust boot OFF switch (Fig. 18, Key Nos. 5 and 7). Disconnect wires from switch.
- Remove two screws (Fig. 19, Key No. 20) from the base. Tip the saw on its side.
- Remove two bolts (Fig. 18, Key No. 33). Remove the foot and bottom cover (Fig. 18, Key Nos. 31 and 32).
- The fan belt (Fig. 18, Key No. 30) can be removed and replaced at this time.
- To replace the other belts, continue and remove the pulley assembly from the base.
- Loosen two bolts and remove the blower assembly (Fig. 18, Key Nos. 12 and 17). Remove flexible tube (Fig. 18, Key No. 22) from blower assembly.
- Loosen two bolts and remove motor assembly (Fig. 18, Key Nos. 23-29).
- Loosen set screw in shaft coupler (Fig. 19, Key Nos. 21 and 22).
- Remove four bolts and vari-speed pulley assembly (Fig. 18, Key Nos. 12 and 15).
- Mark teeth of gears so that they may be assembled in same position as when removed (Fig. 17, Ref. C and D).
- Remove screw, spacer and gear (Fig. 17, Ref. A, B and C).

- Loosen set screw and remove gear (Fig. 17, Ref. D).
- Loosen and remove two bolts and fork assembly (Fig. 17, Ref. E and F).
- Remove bearing plate and bushing (Fig. 17, Ref. G and H).
- Loosen and remove four bolts and front plate (Fig. 17, Ref. I and J). Be careful to not change position of rod.
- Motor drive belt can be removed and replaced at this time.
- Remove snap ring (Fig. 17, Ref. K) and slide pulleys from shaft.
- CAUTION:** Pulleys are under spring tension.
- Remove and replace vari-speed belt.
- Reassemble in reverse order.

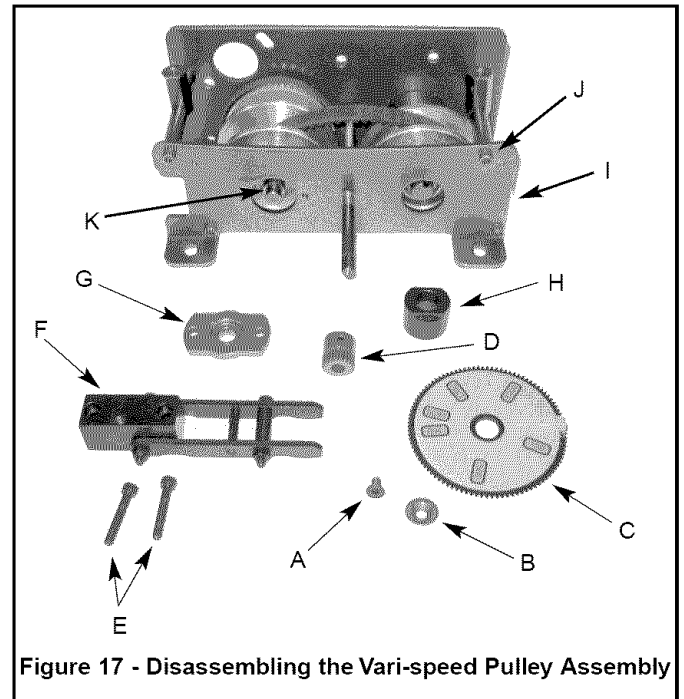

Figure 17 - Disassembling the Vari-speed Pulley Assembly

TROUBLESHOOTING

| SYMPTOM | POSSIBLE CAUSE(S) | CORRECTIVE ACTION |
|------------------------------------|---|---|
| Excessive blade breakage | <ol style="list-style-type: none"> 1. Material not secure on table 2. Blade too coarse for material 3. Teeth in contact with work before sawing 4. Bent blades 5. Blade too thick for wheel diameter 6. Rate of feed too great 7. Cutting a sharp turn | <ol style="list-style-type: none"> 1. Hold workpiece firmly; make sure holddown foot is in contact with top of workpiece. 2. Use finer pitch blade 3. Place blade in contact with work after saw is started and has reached full speed 4. Replace blade 5. Use thinner blade 6. Reduce rate of feed 7. Increase turn radius or use thinner blade |
| Crooked cuts | <ol style="list-style-type: none"> 1. Work not square 2. Rate of feed too great 3. Holddown foot too far from workpiece 4. Dull blade 5. Blade holder loose | <ol style="list-style-type: none"> 1. Adjust tilt of arm at 90° 2. Reduce rate of feed 3. Adjust holddown foot to just contact top of workpiece 4. Replace blade 5. Tighten blade |
| Rough cuts | <ol style="list-style-type: none"> 1. Rate of feed too great 2. Blade too coarse | <ol style="list-style-type: none"> 1. Reduce feed rate 2. Replace with finer blade |
| Motor running too hot | <ol style="list-style-type: none"> 1. Blade too coarse for work 2. Blade too fine for work 3. Excessive dirt and chips | <ol style="list-style-type: none"> 1. Use blade with finer teeth 2. Use blade with coarser teeth 3. Clean thoroughly |
| Saw will not start | Loose electrical connections | Have qualified electrician check electrical connections |
| Dust collection not working | <ol style="list-style-type: none"> 1. Dust collection bag full 2. Obstruction in collection tubes 3. Fan belt loose or broken 4. Impeller loose or broken | <ol style="list-style-type: none"> 1. Empty dust collection bag 2. Clear all collection tubes 3. Replace fan belt 4. Remove blower assembly and inspect. Tighten fan or replace assembly |
| Motor runs; Blade is not moving | <ol style="list-style-type: none"> 1. Loose or broken shaft drive belt 2. Loose or broken motor drive belt 3. Drive shaft loose | <ol style="list-style-type: none"> 1. Check and/or replace shaft drive belt 2. Check and/or replace motor drive belt 3. Check and tighten set screws on drive shaft and pulley |
| Blade speed cannot be changed | Vari-speed pulleys binding on shafts | Apply light machine oil to pulley shafts in belt assembly |
| Blade Loose | Blade needs more tension | Increase blade tension. Remove cover and turn the hex head bolt to increase tension on upper blade holder |

Model 351.224360

Figure 18 - Replacement Parts Illustration for Base

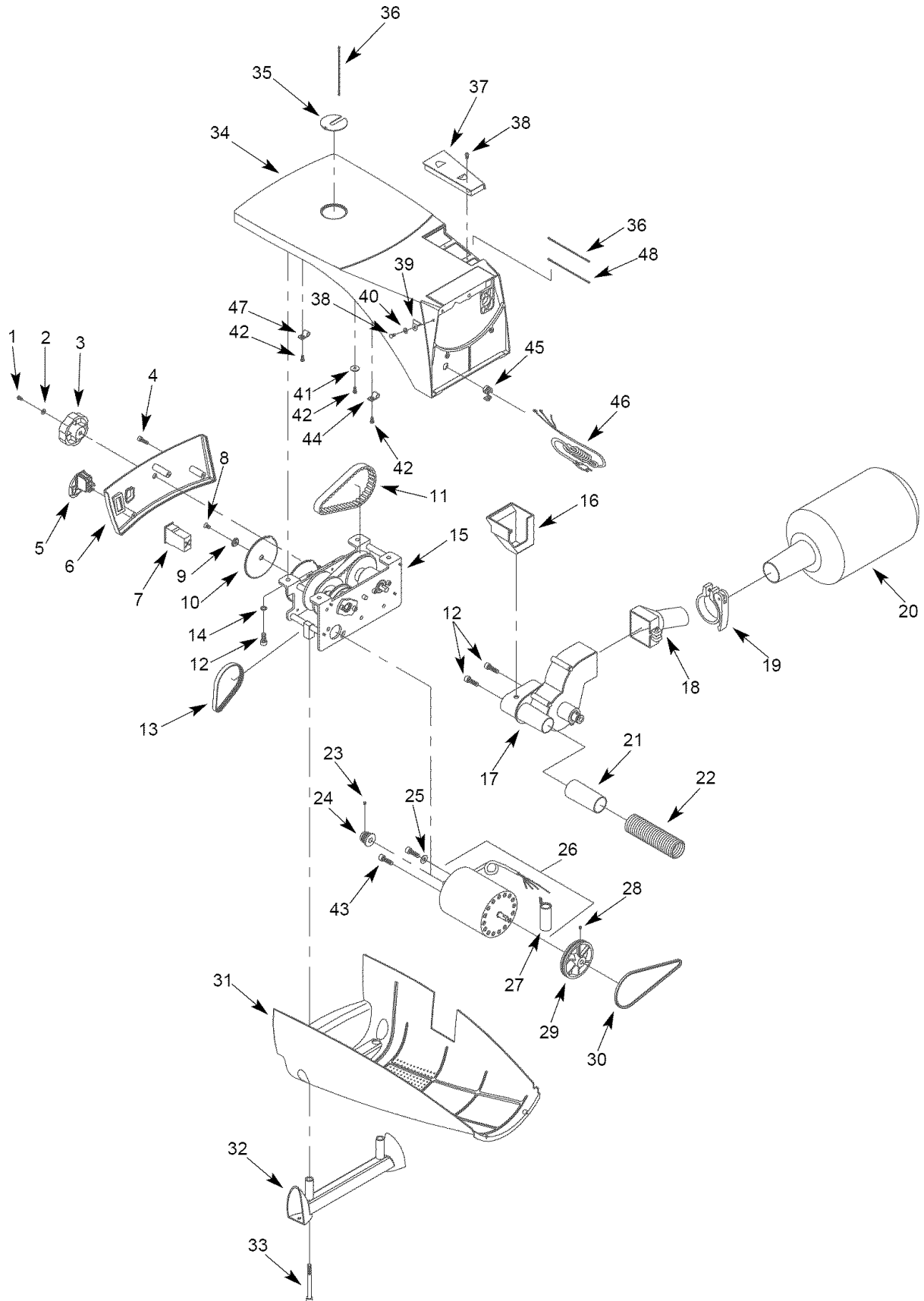

REPLACEMENT PARTS LIST FOR BASE

| KEY NO. | PART NO. | DESCRIPTION | QTY. |
|---------|-----------|---|------|
| 1 | STD863510 | 5-0.8 x 10mm Pan Head Screw* | 1 |
| 2 | 22016.00 | Spacer | 1 |
| 3 | 22017.00 | Knob | 1 |
| 4 | STD870512 | 5-0.8 x 12mm Socket Head Bolt* | 3 |
| 5 | 16080.00 | Switch | 1 |
| 6 | 22018.00 | Front Panel | 1 |
| 7 | 22019.00 | Dust Boot | 1 |
| 8 | 08567.00 | 6-1.0 x 12mm Flat Head Screw | 1 |
| 9 | 22021.00 | Spacer | 1 |
| 10 | 22022.00 | Gear with Label | 1 |
| 11 | 20565.00 | Vari-speed Belt | 1 |
| 12 | STD870820 | 8-1.25 x 20mm Socket Head Bolt* | 6 |
| 13 | 22020.00 | Motor Drive | 1 |
| 14 | STD852008 | 8mm Lock Washer* | 4 |
| 15 | 22023.00 | Vari-speed Pulley Assembly (Incl. Key Nos. 8-11 and 13) | 1 |
| 16 | 22025.00 | Lower Collection Chute | 1 |
| 17 | 22026.00 | Blower Assembly | 1 |
| 18 | 18288.00 | Dust Chute with Screw | 1 |
| 19 | 20777.00 | Bag Clamp | 1 |
| 20 | 20776.00 | Dust Collection Bag | 1 |
| 21 | 22027.00 | Tube | 1 |
| 22 | 22028.00 | Flexible Tube | 1 |
| 23 | STD864406 | 4-0.7 x 6mm Set Screw* | 1 |
| 24 | 22029.00 | 16T Pulley | 1 |
| 25 | 22037.00 | Spacer | 1 |
| 26 | 22030.01 | Motor (Incl. Key No. 27) | 1 |
| 27 | 22031.00 | Capacitor | 1 |
| 28 | 03069.00 | 5-0.8 x 6mm Set Screw | 1 |
| 29 | 22032.00 | Pulley | 1 |
| 30 | 22033.00 | Fan Belt | 1 |
| 31 | 22034.00 | Bottom Cover | 1 |
| 32 | 22035.00 | Foot | 1 |
| 33 | 22036.00 | 8-1.25 x 85mm Socket Head Bolt | 2 |
| 34 | 21978.00 | Base | 1 |
| 35 | 21979.00 | Table Insert | 1 |
| 36 | 21980.00 | Blade, 15 TPI | 1 |
| 37 | 21981.00 | Tool Box Assembly | 1 |
| 38 | STD863408 | 4-0.7 x 8mm Pan Head Screw* | 4 |
| 39 | 21982.00 | Pointer | 1 |
| 40 | STD851004 | 4mm Flat Washer* | 1 |
| 41 | 01474.00 | 5mm Serrated Washer | 1 |
| 42 | STD863508 | 5-0.8 x 8mm Pan Head Screw* | 3 |
| 43 | STD870816 | 8-1.25 x 16mm Socket Head Bolt* | 2 |
| 44 | 22549.00 | Cord Clamp | 1 |
| 45 | 21990.00 | Strain Relief | 1 |
| 46 | 21991.00 | Line Cord | 1 |
| 47 | 00620.00 | Cord Clamp | 1 |
| 48 | 22058.00 | Blade, 18 TPI | 1 |
| Δ | 21975.02 | Operator's Manual | 1 |

* Standard hardware item available locally.

REPLACEMENT PARTS LIST FOR ARM

| KEY NO. | PART NO. | DESCRIPTION | QTY. |
|---------|-----------|--|------|
| 1 | 22012.00 | Blade Guard | 1 |
| 2 | 22013.00 | Holddown Assembly (Incl. Key Nos. 3-7 and 43) | 1 |
| 3 | 22010.00 | 5-0.8 x 50mm Pan Head Screw | 2 |
| 4 | STD851105 | 5mm Flat Washer* | 2 |
| 5 | STD840508 | 5-0.8mm Hex Nut* | 2 |
| 6 | 22009.00 | Blade Guide | 1 |
| 7 | STD852004 | 4mm Flat Washer* | 1 |
| 8 | 22006.00 | Handle Assembly | 1 |
| 9 | 22005.00 | Back Cover Assembly | 1 |
| 10 | 21983.00 | Bracket | 1 |
| 11 | STD852005 | 5mm Lock Washer* | 2 |
| 12 | STD870512 | 5-0.8 x 12mm Socket Head Bolt* | 2 |
| 13 | 01043.00 | 6-1.0 x 8mm Set Screw | 1 |
| 14 | 22004.00 | Dust Guide | 1 |
| 15 | 22003.00 | Shaft Drive Belt | 1 |
| 16 | 22002.00 | Arm Assembly (Inc. Key Nos. 10, 13, 17, 26 and 37-55) | 1 |
| 17 | 22000.00 | Cam | 1 |
| 18 | 21988.00 | Pivot | 1 |
| 19 | 21989.00 | Tilt Plate | 1 |
| 20 | 22550.00 | 5-2.1 x 12mm Thread Forming Screw | 2 |
| 21 | 03069.00 | 5-0.8 x 6mm Set Screw | 1 |
| 22 | 21984.00 | Shaft | 1 |
| 23 | 21985.00 | Swivel Bearing | 1 |
| 24 | 21986.00 | Bearing Flange | 1 |
| 25 | STD863610 | 6-1.0 x 10mm Pan Head Screw* | 2 |
| 26 | STD864406 | 4-0.7 x 6mm Set Screw* | 2 |
| 27 | 21987.00 | 17T Pulley | 1 |

| KEY NO. | PART NO. | DESCRIPTION | QTY. |
|---------|-----------|--------------------------------------|------|
| 28 | STD870512 | 5-0.8 x 12mm Socket Head Bolt* | 1 |
| 29 | 21992.00 | Cover with Switch | 1 |
| 30 | 21993.00 | Cover | 1 |
| 31 | 21994.00 | Work Light Assembly | 1 |
| 32 | 22039.00 | Light Bulb | 1 |
| 33 | 08996.00 | 4 x 60mm Dowel Pin | 2 |
| 34 | 21995.00 | Arm Cover | 1 |
| 35 | 18344.00 | 5-2.1 x 12mm Thread Forming Screw | 1 |
| 36 | 21996.00 | Dust Cover | 1 |
| 37 | 21997.00 | Spring | 1 |
| 38 | 21998.00 | Spring | 1 |
| 39 | STD870425 | 4-0.7 x 25mm Socket Head Bolt* | 1 |
| 40 | 21201.00 | Upper Blade Holder | 1 |
| 41 | 01509.00 | 4 x 25mm Spring Pin | 1 |
| 42 | STD843407 | 4-0.7mm Fiber Hex Nut* | 1 |
| 43 | STD870410 | 4-0.7 x 10mm Socket Head Bolt* | 2 |
| 44 | 22014.00 | Lower Blade Holder | 1 |
| 45 | 15107.00 | 4-0.7 x 4mm Set Screw | 1 |
| 46 | 22043.00 | Eccentric Sleeve | 1 |
| 47 | 22024.00 | Spring | 1 |
| 48 | 22042.00 | Handle | 1 |
| 49 | 22007.00 | Pivot | 1 |
| 50 | 05148.00 | 3AMI-8 Retaining Ring | 1 |
| 51 | 00870.00 | 6-1.0 x 25mm Hex Head Bolt | 1 |
| 52 | STD840610 | 6-1.0mm Hex Nut* | 2 |
| 53 | 21999.00 | Spring | 2 |
| 54 | STD863508 | 5-0.8 x 8mm Pan Head Screw* | 6 |
| 55 | STD833020 | 6-1.0 x 20mm Hex Head Screw* | 1 |
| 56 | STD863408 | 4-0.7 x 8mm Pan Head Screw* | 1 |

* Standard hardware item available locally.

| Recommended Accessories | | Model No. |
|-------------------------|-----------------------------|-----------|
| Δ | Blade 5" x 0.07 x 25 TPI | 9-29444 |
| Δ | Blade 5" x 0.110 x 10 TPI | 9-29440 |
| Δ | Blade 5" x 0.110 x 15 TPI | 9-29441 |
| Δ | Blade 5" x 0.055 x 18.5 TPI | 9-29443 |
| Δ | Blade 5" x 0.110 x 20 TPI | 9-29442 |

Get it fixed, at your home or ours!

Your Home

For repair – **in your home** – of **all** major brand appliances, lawn and garden equipment, or heating and cooling systems, **no matter who made it, no matter who sold it!**

For the replacement parts, accessories and owner's manuals that you need to do-it-yourself.

For Sears professional installation of home appliances and items like garage door openers and water heaters.

1-800-4-MY-HOME® (1-800-469-4663)

Call anytime, day or night (U.S.A. and Canada)

www.sears.com www.sears.ca

Our Home

For repair of carry-in items like vacuums, lawn equipment, and electronics, call or go on-line for the location of your nearest **Sears Parts & Repair Center.**

1-800-488-1222

Call anytime, day or night (U.S.A. only)

www.sears.com

To purchase a protection agreement (U.S.A.) or maintenance agreement (Canada) on a product serviced by Sears:

1-800-827-6655 (U.S.A.)

1-800-361-6665 (Canada)

Para pedir servicio de reparación a domicilio, y para ordenar piezas:

1-888-SU-HOGARSM
(1-888-784-6427)

Au Canada pour service en français:

1-800-LE-FOYER^{MC}
(1-800-533-6937)
www.sears.ca

SEARS

® Registered Trademark / TM Trademark / SM Service Mark of Sears, Roebuck and Co.

® Marca Registrada / TM Marca de Fábrica / SM Marca de Servicio de Sears, Roebuck and Co.

^{MC} Marque de commerce / ^{MD} Marque déposée de Sears, Roebuck and Co.

© Sears, Roebuck and Co.