

GE Monogram®

Use and Care Guide

Stainless Steel
Professional
24" 27" 36" & 48"
Outdoor
Cooking Center

Introduction

Your new Monogram cooking center makes an eloquent statement of style, convenience and home planning flexibility. Whether you chose it for its purity of design, assiduous attention to detail—or for both of these reasons—you’ll find that your Monogram cooking center’s superior blend of form and function will delight you for years to come.

The information on the following pages will help you operate and maintain your cooking center properly.

If you have any other questions—please call the GE Answer Center® 800.626.2000.

In Canada, please call 1.888.880.3030.

OR

Visit our Website at www.monogram.com.

Contents

Care and Cleaning	Problem Solver	27
Burner Grates	Product Registration	4, 29, 30
Burners	Safety Instructions	3, 5–7
Ceramic Briquettes	Warranty for customers in Canada	31
Control Panel and Knobs	Warranty for customers in the USA	32
Drip Trays		
Gourmet Radiant™ Trays	Using the Cooking Center	
Grill Components	Features	8
Grill Rack(s)	Ceramic Briquettes	10
Lava Rocks	Cooking Center	9–14
Orifice Cleaning	Gourmet Radiant™ Trays	9
Rotary Igniter	Grilling Guide	14
Rotisserie	Grilling Hints	13
Spider and Insect Warning	Lava Rocks	10
Stainless Steel	Lighting the Grill	10–12
	Range-Top Burners	15
Consumer Services	Rotisserie	16–20
Important Phone Numbers	Smoker System	21
Model and Serial Number		



TESTED IN ACCORDANCE WITH ANSI Z21.58, LATEST EDITION STANDARD FOR OUTDOOR COOKING GAS APPLIANCES. THIS COOKING CENTER IS FOR OUTDOOR USE ONLY.

Check your local building codes for the proper method of installation. In the absence of local codes, this unit should be installed in accordance with the national Fuel Gas Code No. Z223.1, Latest Edition and the National Electric Code ANSI/NFPA No. 70, Latest Edition.

FOR YOUR SAFETY

If you smell gas:

1. Shut off gas to the appliance.
2. Extinguish any open flame.
3. Open lid.
4. If odor continues, immediately call your gas supplier or your fire department.

▲ WARNING

Do not try lighting this appliance without reading the lighting instructions contained in this Use and Care Guide.

FOR YOUR SAFETY

1. Do not store or use gasoline or other flammable vapors and liquids in the vicinity of this or any other appliance.
2. An LP cylinder not connected for use shall not be stored in the vicinity of this or any other appliance.

POUR VOTRE SÉCURITÉ

Si vous sentez une odeur de gaz :

1. Fermer l'alimentation de gaz vers l'appareil.
2. Éteindre toute flamme nue.
3. Ouvrir le couvercle.
4. Si l'odeur persiste, téléphoner immédiatement à votre fournisseur de gaz ou à votre service d'incendie.

▲ AVERTISSEMENT

Ne pas essayer d'allumer cet appareil sans lire les instructions d'allumage contenues dans ce Guide d'utilisation et d'entretien.

POUR VOTRE SÉCURITÉ

1. Ne pas remiser ou utiliser de l'essence ou autres vapeurs et liquides inflammables près de cet appareil ou de tout autre appareil.
2. Un cylindre de gaz propane non relié pour l'utilisation ne doit pas être remis près de cet appareil ou de tout autre appareil.

Consumer Information

Stainless Steel Outdoor Cooking Center

Before using your cooking center

Read this guide carefully. It is intended to help you operate and maintain your new cooking center properly.

Keep it handy for answers to your questions.

If you do not understand something or need more help, call:

GE Answer Center®
800.626.2000
24 hours a day, 7 days a week
1.888.880.3030 in Canada.

Write down the model & serial numbers

On 36" or 48" models you will find them on a label in the rear of the burner box below the burner grates.

On 27" models you will find them in the back right corner of the cooking center.

On 24" models, you will find them on the angled surface beneath the grill controls.

These numbers are also on the Consumer Product Ownership Registration Card included in this guide.

Before sending in this card, please write these numbers here:

Model Number

Serial Number

Use these numbers in any correspondence or service calls concerning your cooking center.

If you received a damaged cooking center

Immediately contact the dealer (or builder) that sold you the cooking center.

Save time & money

Before you request service, check the Problem Solver in the back of this guide.

It lists causes of minor operating problems that you can correct yourself.

If you need service

To obtain service, see the Consumer Services page in the back of this guide.

We are proud of our service and want you to be pleased. If for some reason you are not happy with the service you receive, here are steps to follow for further help.

FIRST, contact the people who serviced your appliance. Explain why you are not pleased. In most cases, this will solve the problem.

NEXT, if you are still not pleased, write all the details—including your phone number—to:

Manager, Consumer Relations
GE Appliances
Appliance Park
Louisville, KY 40225

IMPORTANT SAFETY NOTICE

- **The California Safe Drinking Water and Toxic Enforcement Act** requires the Governor of California to publish a list of substances known to the state to cause cancer, birth defects or other reproductive harm, and requires businesses to warn customers of potential exposure to such substances.
- **Gas appliances can cause minor exposure to four of these substances**, namely benzene, carbon monoxide, formaldehyde and soot, caused primarily by the incomplete combustion of natural gas or LP fuels.

Properly adjusted burners, indicated by a bluish rather than a yellow flame, will minimize incomplete combustion. Exposure to these substances is minimized because this is an outdoor unit.

SAFETY PRECAUTIONS

When using your appliance, follow basic safety precautions, including the following:

- **Be sure your appliance is properly installed and grounded** by a qualified technician in accordance with the provided installation instructions.
- **Do not attempt to repair or replace any part of your cooking center unless it is specifically recommended in this guide.** All other servicing should be referred to a qualified technician.
- **Have the installer show you where the gas shut-off valve is located** so that you know where to shut off the gas to the cooking center.
- **If you smell gas**, the installer has not done a proper job of checking for leaks. You can have a small leak and therefore a faint gas smell if the connections are not completely tight.

Finding a gas leak is **NOT** a do-it-yourself procedure. Some leaks can only be found with the burner control in the ON position and for your protection it must be done by a qualified service technician. Never use an open flame to locate a leak.
- **This cooking center is for outdoor use only.** Tested in accordance with ANSI Z21.58, Latest Edition standard for outdoor cooking gas appliances.
- **Check your local building codes for the proper method of installation.** In the absence of local codes, this unit should be installed in accordance with the National Fuel Gas Code No. Z223.1, Latest Edition and the National Electrical Code ANSI-NFPA No. 70, Latest Edition.
- **Do not try lighting this appliance without reading the lighting instructions in this guide.**
- **Read this guide carefully and completely before using your cooking center** to reduce the risk of fire, burn hazard or other injury. Please retain this guide for future reference.
- **This outdoor cooking gas appliance is not intended to be installed in or on recreational vehicles and/or boats.**
- **Never allow anyone to sit, stand or play on or around the cooking center at any time.** When in use, portions of the cooking center get hot enough to cause severe burns.
- **Do not store items of interest to children around or below the cooking center, in the cart or built-in enclosure.**
- **Never allow children to crawl inside a cart or enclosure.**
- **Never let clothing, pot holders or other flammable materials come in contact with or too close to any grate, burner or hot surface until it has cooled.** Fabric may ignite and result in personal injury.
- **Do not use water on grease fires. Never pick up a flaming pan.** Turn the controls off. Smother a flaming pan on a burner by covering the pan completely with a well-fitting lid, cookie sheet or flat tray. Use a multi-purpose dry chemical or foam-type fire extinguisher.

Flaming grease outside a pan can be put out by covering it with baking soda or, if available, by using a multi-purpose dry chemical or foam-type fire extinguisher.

SAFETY PRECAUTIONS

- **Use this appliance only for its intended use** as described in this guide.
- **Children should not be left alone or unattended in an area where the cooking center is being used.**
- **Do not leave the cooking center unattended while cooking.**
- **For personal safety, wear proper apparel.** Loose fitting garments or sleeves should never be worn while using this appliance. Some synthetic fabrics are highly flammable and should not be worn while cooking.
- **Only certain types of glass, heat-proof glass ceramic, earthenware, or other glazed utensils are suitable for grill use.** Unsuitable types of materials may break with sudden temperature changes. Use only on low or medium heat settings according to the manufacturer's directions.
- **Do not heat unopened food containers** as a build-up of pressure may cause the container to burst.
- **Use a pot holder when opening the roll top lid.** Open the lid slowly to allow heat and steam to escape.
- **Use only dry pot holders**—moist or damp pot holders on hot surfaces may result in burns from steam. Do not use a towel or other bulky cloth in place of a pot holder. Do not let pot holders touch hot portions of the grill rack or burner grates.
- **Never lean over an open grill.**
- **Pay close attention when lighting a burner.** Be certain you are rotating the igniter labeled for the burner you intend on using.
- **When using the grill, do not touch the grill rack, burner grate or immediate surrounding areas** as these areas become extremely hot and could cause burns. **Keep children away!**
- **Grease is flammable. Let hot grease cool before attempting to handle it.** Avoid letting grease deposits collect in the drip pans. Clean the drip pans often. (On some models)
- **Do not use aluminum foil to line drip pans or grill racks.** This can severely upset combustion air flow or trap excessive heat in the control area. The result of this can be melted knobs or rotary igniters.
- **When using the range-top burners always use flat-bottomed pans which are large enough to cover the burner.** Adjust the flame so that it heats only the bottom of the pan to avoid ignition of clothing. Position handles inward away from open edges of the unit to avoid burns associated with spillovers. Hold the handle of the pan with a pot holder when turning or stirring food.
- **Do not use the grill for cooking excessively fatty meats or products which promote flare-ups.**
- **Never grill without the drip pan in place and pushed all the way to the back of the grill.** Without it, hot grease could leak downward and produce a fire or explosion hazard.
- **Never rotisserie cook without the basting pan in place and pushed all the way to the back of the grill.** Without it, hot grease could leak downward and produce a fire or explosion hazard.
- **For proper lighting and performance of the burners** it is necessary to keep the ports clean.
- **Clean the grill with caution.** To avoid steam burns, do not use a wet sponge or cloth to clean the grill while it is hot. Some cleaners produce noxious fumes or can ignite if applied to a hot surface.
- **Do not operate the cooking center under unprotected combustible construction.** Use only in well ventilated areas. Do not use in buildings, garages, sheds, breezeways or other such enclosed areas. This unit is for outdoor use only.
- **Do not locate the cooking center where the grill exhaust is directed at combustible materials,** windows (open or closed), doorways, etc. The grill vents combustion gases and smoke to the back of the appliance.
- **Keep the area surrounding the cooking center free from combustible materials,** trash, or combustible fluids and vapors such as gasoline or charcoal lighter fluid. Do not obstruct the flow of combustion and ventilation air.
- **Cook meat and poultry thoroughly—meat to at least an INTERNAL 160°F. and poultry to at least an INTERNAL 180°F.** Cooking to these temperatures usually protects against foodborne illness.

SAFETY PRECAUTIONS

- **At least once a year, the unit should be inspected** for the presence of spiders, spider webs or other insects. The burner area is a common and desired spider haven and can present a dangerous condition which can damage the cooking center and render it unsafe for use. The presence of spiders, spider webs or other insects can cause the gas to flow from the front of the burner. This is a very dangerous condition which can cause a fire to occur behind the valve panel. Check the cooking center immediately if any of the following conditions exist:
 1. The smell of gas in conjunction with extreme yellow tipping of the burner flames.
 2. The grill or range-top burners do not reach temperature.
 3. The grill or range-top burners heat unevenly.
 4. The burners make popping noises.
- **Do not use charcoal on the grill.**
- **Keep any electrical supply cord, or the rotisserie motor away from the heated areas of the cooking center.**
- **Never use the cooking center in windy conditions.** If located in a consistently windy area (oceanfront, mountaintop, etc.) a wind break will be required. Always adhere to the specified clearances listed in the installation instructions.
- **The 24" professional grill is designed for single rows of ceramic briquettes to be placed in the stainless steel radiant trays above the grill burners.** To avoid blocking off the area for the grill burners to vent, do not place the ceramic briquettes over the holes in the stainless steel radiant trays. Placing the ceramic briquettes over the holes in the stainless steel radiant trays can damage ignition components and knobs and void the warranty.
- **Some 27", 36" and 48" professional grills utilize Gourmet Radiant™ Trays to evenly distribute heat and to minimize cooking flare ups.** Do not place lava rocks on top of the Gourmet Radiant™ Trays. This can damage the knobs and ignition components and void the warranty.
- **Some 27", 36" and 48" professional grills are designed for a single layer of lava rock to be spread evenly over the stainless steel radiant tray above the grill burners.** To avoid blocking off the area for the grill burners to vent, do not use more than a single layer of lava rock. Adding excess rock can damage ignition components and knobs and void the warranty.
- **Natural gas model grills:** Be sure to **CLOSE** the manual safety valve supplying the unit after every use of the grill.
- **LP gas models:** Be sure to **CLOSE** the LP tank mounted valve after every use of the grill.
- **If a cart unit is stored indoors ensure that it is cool before attempting to move it.** If LP, the cylinder must be unhooked and the LP cylinder stored outside in a well ventilated area, out of the reach of children. From the caster side of the cooking center push, never pull, the cooking center.
- **Never use a dented or rusty LP tank.** See the requirements in the installation instructions.
- **Never put more than one LP cylinder below a cart-mounted cooking center.** Never modify the cart to house a larger cylinder or more than one cylinder at a time. Do not store spare tanks in a built-in enclosure.
- **Keep the ventilation openings of the LP cylinder enclosure free and clear from debris.**
- **LP units require an LP tank** equipped with a type 1 connector and an over-fill protection device. If you use a tank exchange system, be sure to **exchange this tank for a similarly equipped tank.**

SAVE THESE INSTRUCTIONS

Features of Your Cooking Center

Stainless Steel Outdoor Cooking Center

Design information

(Not all features are on all models. Appearance may vary throughout this Guide.)

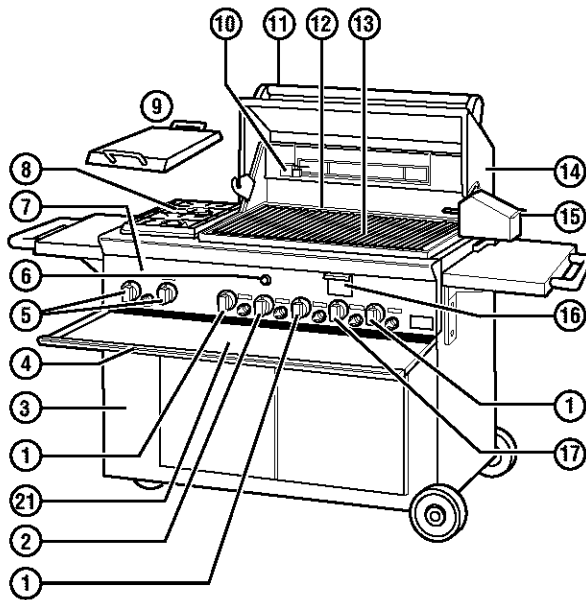

With Rotisserie	Without Rotisserie
ZGG48L31	ZGG48L30
ZGG48N31	ZGG48N30
ZGG48L42	ZGG48L40
ZGG48N42	ZGG48N40

Feature Index	Page
1 Grill Control(s)	11
2 Rotisserie Control(s)	17
3 LP Gas Cylinder Enclosure	---
4 Drip Tray	20
5 Range-Top Burner Controls	14
6 Safety Valve Button	17
7 Lighting Instructions (location may vary)	---
8 Range-Top Burners (on some models)	14
9 Burner Cover	14
10 Rotisserie Electrode Cover	---
11 Insulated Handle	---
12 Model and Serial Numbers	4, 30
13 Grill Rack(s)	9-12
14 Roll Top Lid	11, 17, 19
15 Rotisserie Motor Assembly	16
16 Smoker System	19
17 Smoker Control	19
18 Rotisserie Basting Pan	17
19 LP Tank (on some models)	10
20 Match Lighting Hole	11
21 Match Stick Extension Rod	---

Grill covers are available from our Parts and Accessories.

Call 800.626.2002

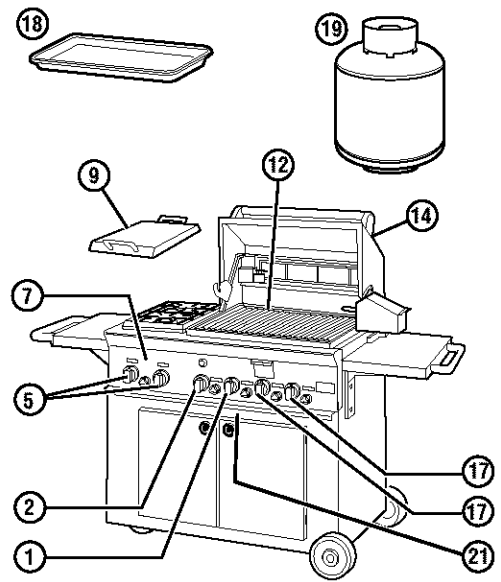

With Rotisserie	Without Rotisserie
ZGG36L21	ZGG36L20
ZGG36N21	ZGG36N20
ZGG36L31	ZGG36L30
ZGG36N31	ZGG36N30

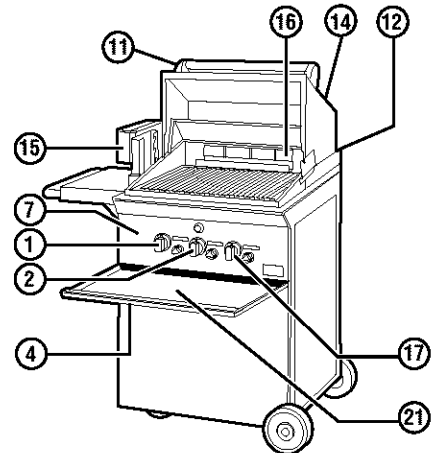

With Rotisserie	Without Rotisserie
ZGG27L21	ZGG27L20
ZGG27N21	ZGG27N20

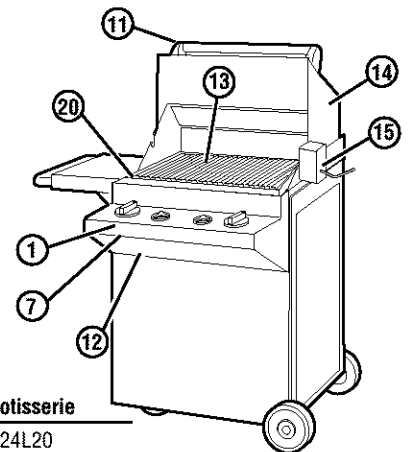

With Rotisserie
ZGG24L20

The Grill

Stainless Steel Outdoor Cooking Center

General information

The grill section consists of a large cast iron burner or burners (depending on model), a series of stainless steel heat baffles (on some models), a bed of natural lava rocks or ceramic briquettes, or Gourmet Radiant™ Trays (depending on model) and a porcelain enameled heat retaining grill rack(s).

Each burner is rated at 15,000 BTU for 24" models.

Each burner is rated at 20,000 BTU for 27", 36" and 48" models.

Below each burner is a stainless steel heat baffle (on some models) which reflects usable heat upward into the cooking area and reduces the temperature of the drip pan below (on some models).

The cast iron grill burner encompasses the entire cooking area and is top ported to operate cooler and last longer.

On some models, the burners in the cooking area are side ported.

Above the burner(s) on 24" models are two stainless steel radiant tray(s) which support ceramic briquettes and protect the grill burner ports from blockage.

The Gourmet Radiant™ Trays (on some models) protect the grill burner ports from blockage on some 27", 36" and 48" models.

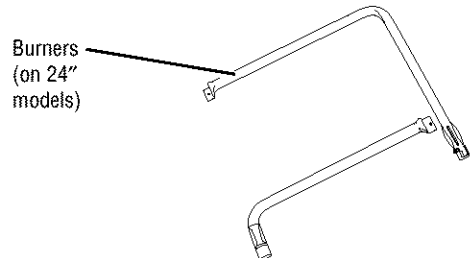
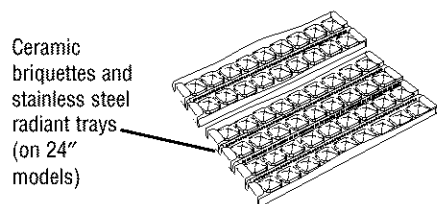
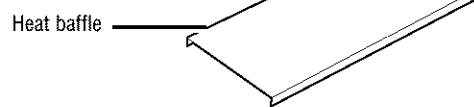
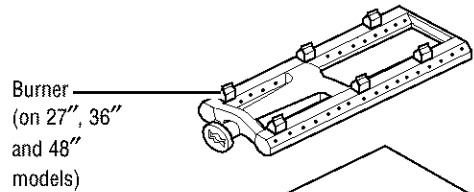
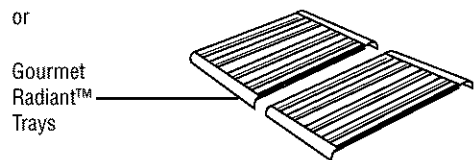
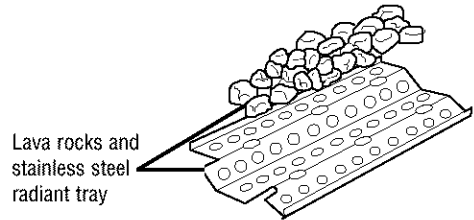
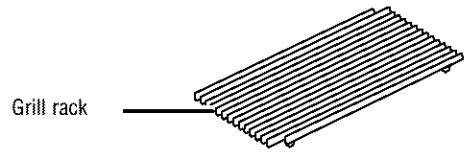

Gourmet Radiant™ Trays

(on some models)

Some grills are supplied with Gourmet Radiant™ Trays. They are uniquely shaped and effectively distribute the heat from the burners evenly across the grill area.

Flare ups are minimized because the Gourmet Radiant™ Trays quickly redirect grease down to the drip pan before it can begin to burn.

The intense heat produced by this system produces true grilled flavor as fats and juices are brought to the surface of the food and caramelized.

Lava rock *(on some models)*

The grill is supplied with natural lava rock (on some models). Because of the porosity of natural lava rock it is superior in its ability to capture heat as it rises from the grill burners. It also possesses the thermal mass needed for professional results. Flare-ups are controlled because the lava radiant keeps grease from getting to the flames and igniting.

The intense heat produced by this system produces true grilled flavor as fats and juices are brought to the surface of the food and caramelized.

Place lava rocks in a single layer on top of the stainless steel radiant tray located under the grill rack. It is important to distribute the rocks evenly over the tray without leaving any large gaps. Uneven distribution of the rocks and air gaps can cause localized “hot” and “cold” spots which could result in unsatisfactory cooking performance.

Ceramic briquettes *(on some models)*

The intense radiant heat from the ceramic briquettes caramelizes the fats and juices that are brought to the surface of the food, giving it the barbecued flavor.

The ceramic briquettes are in two separate stainless steel trays located under the grill

racks. The small tray is to be placed in the back and the large tray is to be placed in the front. (See the Rotisserie section for placement when rotisserie cooking.)

Make sure the briquettes are in place in the trays so that they do not cover the holes in the trays.

Before lighting the grill

WARNING: IMPORTANT!

Inspect the gas supply piping or hose prior to turning the gas on. If there is evidence of cuts, wear or abrasion, it must be replaced prior to use. Any replacement pressure regulators or hose assembly must be the type specified by the manufacturer.

For LP use, the pressure regulator and hose assembly supplied with the unit must be used.

This LP tank is equipped with overflow protection. When you refill or trade in your tank, make sure the one you receive also has overflow protection.

If the grill uses LP gas, connect the regulator to the LP tank and check the hose and regulator connections for leaks with a soap and water solution before operating the grill.

Keep a spray bottle of soapy water near the gas supply valve and check the connections for gas leaks before each use.

Turn all knobs to OFF then turn on the gas supply.

Do not use the grill if the odor of gas is present.

AVERTISSEMENT : IMPORTANT!

Inspecter la canalisation d'alimentation de gaz ou le tuyau avant d'allumer le gaz. S'il existe un indice de coupure, usure ou abrasion, cette canalisation doit être remplacée avant l'utilisation de l'appareil. Tous les régulateurs de pression ou montage de tuyau de remplacement doivent être du type spécifié par le fabricant.

Pour l'utilisation avec le gaz propane, le régulateur de pression et le montage de tuyau fournis avec l'appareil doivent être utilisés.

Ce réservoir de gaz propane est muni d'un dispositif de protection contre le remplissage excessif. Lorsque vous remplissez de nouveau ou échangez votre réservoir, s'assurer que celui que vous recevez a aussi une protection contre le remplissage excessif.

Si le gril utilise du gaz propane, connecter le régulateur au réservoir de gaz propane et vérifier les connexions du tuyau et du régulateur pour les fuites, avec une solution de savon et d'eau avant de faire fonctionner le gril.

Garder une bouteille de vaporisation d'eau savonneuse près du robinet d'alimentation de gaz et vérifier les connexions pour les fuites de gaz avant chaque utilisation.

Tourner tous les boutons à OFF (ARRÊT) ensuite ouvrir l'approvisionnement de gaz.

Ne pas utiliser le gril s'il existe une odeur de gaz.

To light the grill

Always keep your face and body as far away from the grill as possible when lighting.

Open the lid, push and turn the grill control knob to the LITE position and immediately turn the rotary igniter knob of the spark igniter next to the grill control knob. You will hear a snapping sound. At the same time a spark will be provided at the grill burner.

It may be necessary to turn the rotary igniter knob several times until the burner is lit. If the burner does not light in 4 seconds, turn both knobs to OFF and wait 5 minutes, for any accumulated gas to dissipate, before trying again.

On some models, a match stick extension rod is provided inside the grill drip pan. To match light a main grill burner, insert the UNLIT match stick securely into the clip end of the extension rod. Keep your face as far away from the grill as possible, light the match stick and, holding the end of the rod, pass the flame of the lit match through the grill rack, past the radiant tray directly in front of a burner port. Push and turn the control knob, which is centered on the burner you are trying to light, to the LITE position. If the burner does not light after 4 seconds, turn the knob OFF. Wait 5 minutes, for any accumulated gas to dissipate, before trying to light the burner again. If the burner will not light after several attempts see the Problem Solver in the back of this guide.

On some models, a match lighting hole is provided on the top left and right edges under the lid. Open the lid and use the lighting hole on the left top edge. Push and turn the control knob, which is centered on the burner you wish to light, to LITE. If the burner does not light in 4 seconds turn the knob OFF. Wait 5 minutes and try again. If the burner will not light after several attempts, see the Problem Solver in the back of this guide.

NOTE:

- Do not attempt to light the grill if the odor of gas is present. Call for service.
- Always wait 5 minutes before relighting a hot grill.

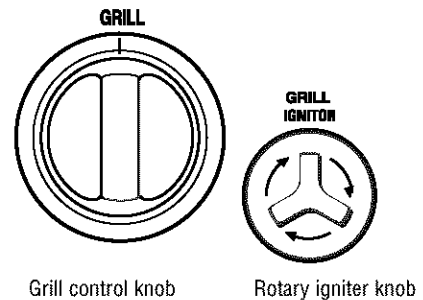

Each grill burner has its own rotary igniter.

Match lighting hole on some models (See the Features page for match lighting hole location for your model.)

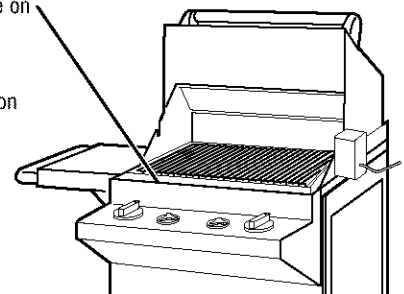

Allumage du gril

Toujours garder le visage et le corps aussi loin que possible du gril lors de l'allumage.

Ouvrir le couvercle, appuyer et tourner le bouton de commande du gril à la position LITE (allumage) et tourner immédiatement le bouton d'allumage rotatif de l'allumeur à étincelle, près du bouton de commande du gril. Un bruit sec se fait entendre. En même temps, une étincelle sera fournie au brûleur du gril.

Il peut être nécessaire de tourner le bouton d'allumage rotatif plusieurs fois jusqu'au moment où le brûleur s'allume. Si le brûleur ne s'allume pas en moins de 4 secondes, tourner les deux boutons à OFF (arrêt) et attendre 5 minutes pour que tout le gaz accumulé se dissipe, avant d'essayer de nouveau l'allumage.

Sur certains modèles, une allonge de tige d'allumette est fournie à l'intérieur de la lèche-frite du gril. Pour allumer un brûleur principal du gril avec une allumette, introduire la tige d'allumette NON ALLUMÉE solidement dans l'extrémité à pince de l'allonge de tige. Garder votre visage aussi loin que possible du gril, allumer l'allumette et en tenant l'extrémité de l'allonge, passer la flamme à travers la grille au-delà du plateau radiant directement vis-à-vis d'un orifice de brûleur. Appuyer sur le bouton de commande centré sur le brûleur que vous essayez d'allumer et le tourner à la position LITE. Si le brûleur ne s'allume pas en quatre secondes, tourner le bouton à OFF. Attendre 5 minutes pour que le gaz accumulé se dissipe avant d'essayer de nouveau d'allumer le brûleur. Si le brûleur ne s'allume pas après plusieurs essais, voir la solution proposée pour résoudre le problème au verso de ce guide.

Sur certains modèles, un trou d'allumage est fourni sur les bords supérieurs gauche et droit sous le couvercle. Ouvrir le couvercle et utiliser le trou d'allumage sur le bord supérieur gauche. Appuyer et tourner le bouton de commande, vis-à-vis le brûleur que vous désirez allumer, à la position LITE (allumage). Si le brûleur ne s'allume pas en quatre secondes, tourner le bouton à OFF (arrêt). Attendre 5 minutes et essayer de nouveau. Si le brûleur ne s'allume pas après plusieurs essais, voir la solution pour résoudre le problème au verso de ce guide.

REMARQUE :

- Ne pas essayer d'allumer le gril si une odeur de gaz existe. Faire venir le service d'entretien.
- Toujours attendre 5 minutes avant de réallumer un gril chaud.

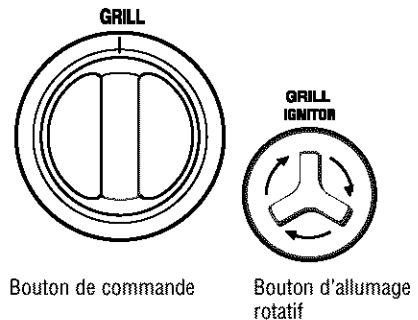

Chaque brûleur du gril a son propre allumeur rotatif

Trou d'allumage sur certains modèles (Voir la page des caractéristiques pour l'emplacement du trou d'allumage sur votre modèle.)

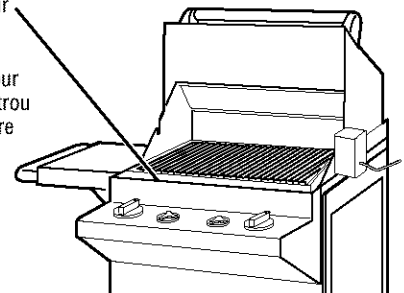

Using the grill

Grilling requires high heat for searing and proper browning. Most foods are cooked at the HI heat setting for the entire cooking time. However, when grilling large pieces of meat or poultry, it may be necessary to turn the heat to a lower setting after the initial browning. This cooks the food through without burning the outside.

Foods cooked for a long time or basted with a sugary marinade may need a lower heat setting near the end of the cooking time.

Do not leave the grill unattended while cooking.

1. Check to be certain the drip tray is in place.
2. Light the grill using the instructions in the *To light the grill* section of this guide.
3. Turn the control knob to HI and preheat the grill for 10–15 minutes. The roll top lid is to be closed during preheating.
4. Place the food on the grill and cook to the desired doneness. The control knob may be set to any position to adjust the heat setting if necessary.

NOTE: The hot grill sears the food, sealing in the juices. The longer you preheat the grill, the faster the meat browns and the darker the grill marks will be.

Grilling hints

- When turning the meat over, always use a spatula as it will not puncture the meat allowing the juices to run out. This will help to keep the meat juicy. Turn the meat only once, as juices are lost when the meat is repeatedly turned. Season or salt the meat after it has been cooked; these procedures have a tendency to dry the meat out.
- Be sure to trim any excess fat from meat or poultry. To prevent steaks or chops from curling while they are being cooked, slit the fat around the edges at about 2-inch intervals. To test for doneness, make a small cut in the center of the meat.
- The doneness of meat is affected by the thickness of the cut. It is impossible to cook a thin piece of meat to a rare doneness. A steak should be at least 1-inch thick to have it turn out rare and juicy. The cooking time is affected by the temperature of the meat when you start to cook it, the size and shape of the cut and the kind of meat you are cooking. The degree of doneness desired also affects the time.
- The U. S. Department of Agriculture says, “Rare beef is popular, but you should know that cooking it to only 140°F. means some food poisoning organisms may survive.” (Source: Safe Food Book, Your Kitchen Guide. USDA Rev. June 1985.)
- When defrosting meats it is recommended that it be done overnight in the refrigerator as opposed to a microwave. This in general yields a juicier cut of meat.
- Always ensure that the meat is thoroughly cooked by using a meat thermometer.

Grilling guide

This is a suggested guide only. There are many variables that will affect cooking performance. These include wind, temperature, humidity and cut of meat.

Food	Weight/ Thickness	Flame Size	Approximate Time	Comments
Fresh Vegetables <i>Beets, carrots, turnips</i>		Medium	12 to 20 min.	Slice. Dot with butter or margarine. Wrap in heavy duty foil. Turn occasionally.
<i>Onion</i>	1/2" slices	Medium	8 to 20 min.	Brush occasionally with melted butter or margarine. Turn once.
<i>Sweet potatoes</i>	Whole	Medium	40 to 60 min.	Wrap individually in heavy duty foil. Rotate occasionally.
<i>White potatoes</i>	6 to 8 ounces	High	45 to 60 min.	Wrap individually in heavy duty foil. Rotate occasionally.
Frozen Vegetables <i>Asparagus, broccoli, brussels sprouts, green beans, peas</i>		Medium	15 to 30 min.	Dot with butter or margarine and a small amount of water. Wrap in heavy duty foil. Turn occasionally.
Beef <i>Hamburgers</i>	1/2" to 3/4"	Medium High	10 to 18 min. 6 to 15 min.	Turn once when juices rise to the surface. Do not leave unattended. A flare-up could occur.
<i>Steaks—rare (140°)</i>	1" 1 1/2"	High High	8 to 14 min. 11 to 18 min.	Remove excess fat from edge. Slash remaining fat at 2" intervals. Turn once.
<i>Steaks—medium (160°)</i>	1" 1 1/2"	Medium to High	12 to 22 min. 16 to 27 min.	
<i>Steaks—well done (170°)</i>	1" 1 1/2"	Medium Medium	18 to 30 min. 16 to 35 min.	
Lamb Chops/Steaks <i>Rare (140°)</i>	1" 1 1/2"	High High	10 to 15 min. 14 to 18 min.	Remove excess fat from edge. Slash remaining fat at 2" intervals. Turn once.
<i>Medium (160°)</i>	1" 1 1/2"	Medium to High	13 to 20 min. 18 to 25 min.	
<i>Well done (170°)</i>	1"	Medium	17 to 30 min.	
Pork <i>Chops</i>	1" 1 1/2"	Medium Medium	15 to 40 min. 25 to 60 min.	Remove excess fat from edge. Slash remaining fat at 2" intervals. Turn once. Cook well done.
<i>Ribs</i>		Medium	40 to 60 min.	Turn occasionally. During the last few minutes, brush with barbecue sauce, turn several times.
<i>Precooked ham steaks</i>	1/2"	High	4 to 8 min.	Remove excess fat from edge. Slash remaining fat at 2" intervals. Turn once.
<i>Hot dogs</i>		Medium	5 to 10 min.	Slit skin. Turn once.
Poultry <i>Broiler fryer, halved or quartered</i>	2 to 3 lbs.	Low Medium	1 to 1 1/2 hours 40 to 60 min.	Place skin side up. Turn frequently brushing with melted butter, margarine, oil or marinade.
<i>Breasts</i>		Medium	30 to 45 min.	
Fish and Seafood <i>Steaks: halibut, salmon, swordfish</i>	3/4" to 1"	Low to Medium	8 to 15 min.	Turn once. Brush with melted butter, margarine or oil to keep moist.
<i>Whole catfish, rainbow trout</i>	4 to 8 ounces	Low to Medium	12 to 20 min.	Turn once. Brush with melted butter, margarine or oil to keep moist.

Range-Top Burners

Stainless Steel Outdoor Cooking Center

Range-top burners

(on some models)

Some cooking centers are equipped with heavy cast iron burners. Each is rated at 15,000 BTU and has a rotary spark igniter for efficient lighting.

The burner grates are porcelain enamel over cast iron for durability.

Each cooking center comes with a stainless steel cover which doubles as a work surface. When using the grill burners with the work surface in place, be careful as heat can conduct from the grill section and cause the work surface to heat up.

Never attempt to light the range-top burners with the work surface in place.

Cover the range-top burners with the stainless steel cover when not in use.

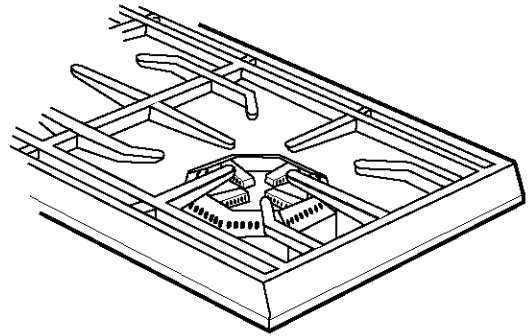

To light a range-top burner

(on some models)

First remove the burner cover, by lifting up and to the side, or any cooking utensils from the burner grate.

CAUTION: The burner cover may be hot if the grill burners are in operation.

MISE EN GARDE : Le couvercle du brûleur peut être chaud si les brûleurs du gril sont en fonctionnement.

Push and turn the control knob to the LITE position and immediately turn the rotary igniter knob (between the rear and front burner knobs) until the burner is lit or 4 seconds pass.

If the burner doesn't ignite wait 5 minutes for any accumulated gas to dissipate then try again.

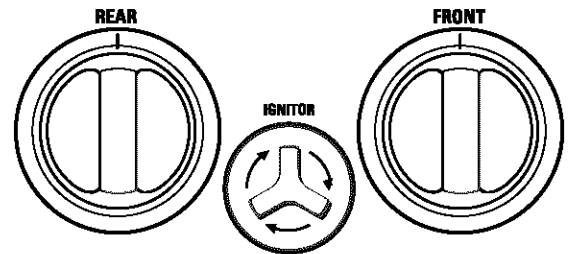

If the burner will not light after several attempts, wait 5 minutes. The burner can be lit by holding a lit match next to the burner ports and turning the control knob to LITE.

Flame height

The correct height of the flame depends on the size and material of the pan being used, the food being cooked and how much liquid is in the pan.

- The flame should never extend beyond the bottom of the pan.
- Pans that conduct heat slowly (such as glass-ceramic) should be used with low or medium flame unless you are cooking with a large amount of liquid.

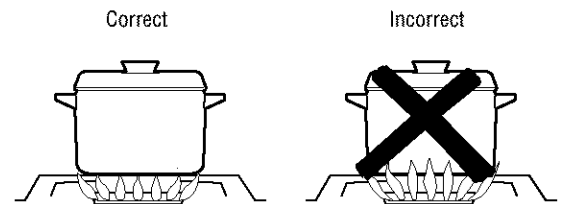

Note: The flame size on a gas burner should match the cookware you are using.

Rotisserie system

(on some models)

The rotisserie system is designed to cook items from the back of the grill using infrared heat.

The rotisserie motor is equipped with metal gears and is capable of turning up to a 12, 15 or 20 lb. cut of meat or poultry, depending on the model. The actual capacity is limited by clearance and motor torque.

Maximum 24" model 12 lb. turkey

Maximum 27" model 15 lb. turkey

Maximum 36", 48" models 20 lb. turkey

The rotisserie burner (on some models) is an infrared type which provides intense searing radiant heat. This intense heat is magnificent for searing in the natural juices and nutrients found in quality cuts of meat.

Once lit, the rotisserie burner will reach cooking temperatures in about 1 minute. The orange/red glow will even out in about 5 minutes.

WARNING: Electrical Grounding Instructions

This appliance rotisserie motor is equipped with a three-prong (grounding) plug for your protection against shock hazard and should be plugged directly into a properly grounded three-prong receptacle. Do not cut or remove the grounding prong from the plug.

The rotisserie motor must be electrically grounded in accordance with local codes or, in the absence of local codes, with the National Electrical Code, ANSI/NFPA 70-1990.

If an extension cord is required to operate the rotisserie motor, use only a grounded cord approved for outdoor use. Use as short of cord as possible and avoid wet areas.

AVERTISSEMENT : Instructions de mise à la terre électrique

Ce moteur de la rôtisserie de l'appareil est muni d'une fiche à trois broches (mise à la terre) pour votre protection contre le risque de choc et doit être branché directement dans une prise de courant à trois alvéoles dûment reliée à la terre. Ne pas couper ni enlever de la fiche la broche de liaison à la terre.

Le moteur de la rôtisserie doit être relié à la terre électriquement conformément aux codes locaux ou, à défaut de codes locaux, selon le Code électrique national, ANSI/NFPA 70-1990.

Si une rallonge est requise pour faire fonctionner le moteur de la rôtisserie, utiliser un cordon relié à la terre et approuvé pour utilisation en plein air. Utiliser un cordon aussi court que possible et éviter les endroits mouillés.

Assembly

On 24" models the motor is mounted by sliding it down into place in the metal channel attached to the right side of the grill. The skewer is connected to the motor assembly by placing the pointed end through the motor access hole in the grill and into the motor. The left side of the skewer rests in the grill groove.

On 27" models the motor is mounted to a metal channel which attaches to the left side of the grill and is tightened into place with a thumb screw. Ensure that the motor is straight prior to tightening the thumb screw.

The rotisserie motor on 36" and 48" models is secured down to a cast rotisserie block with the black screw-down knob. The rotisserie block is in turn bolted to the right side panel.

On 36" and 48" models, the skewer or the rotisserie is attached to the motor assembly by placing the pointed end into the motor and resting the threaded end on the support at the left side (right side on 27" models) of the grill.

With the skewer pushed as far as possible into the motor, the grooved skewer bushing should rest on the left side bracket. (It will rest on the right side on 27" models.)

The removable black handle should only be in place when handling the skewer. Remove the handle when cooking to allow the lid to close and avoid melting the handle with heat from the range-top burners (on some models).

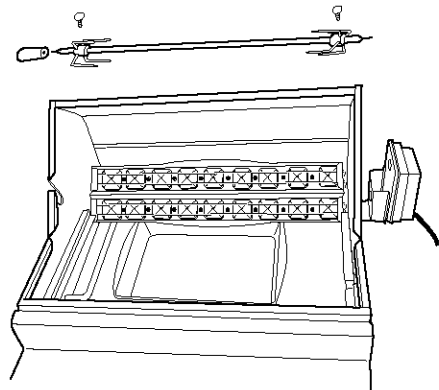

24" model rotisserie assembly

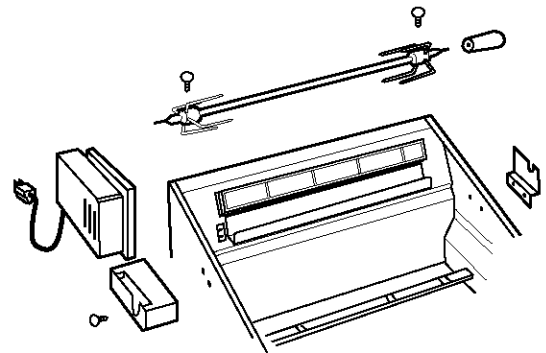

27" model rotisserie assembly

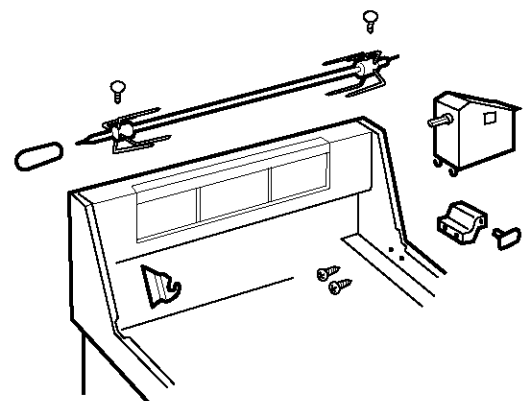

36" and 48" model rotisserie assembly

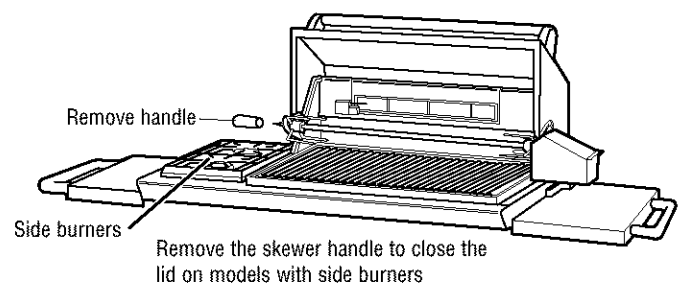

To setup the grill for rotisserie

(24" models only)

1. Open the lid.
2. Remove the grill racks.
3. Remove the front large stainless steel radiant tray with briquettes.
4. Remove the back small stainless steel radiant tray with briquettes and place it into the rotisserie cooking position by sliding it into the rotisserie cooking slots.
5. Place the basting pan, on the grill floor, inside the grill compartment, against the bottom of the stainless steel radiant tray.
6. Assemble the rotisserie motor and skewer.
Use only the small, stainless steel radiant tray with briquettes in the rotisserie cooking position. The large stainless steel radiant tray with briquettes is not used during rotisserie cooking.
7. Use the REAR GRILL control only, for rotisserie cooking.

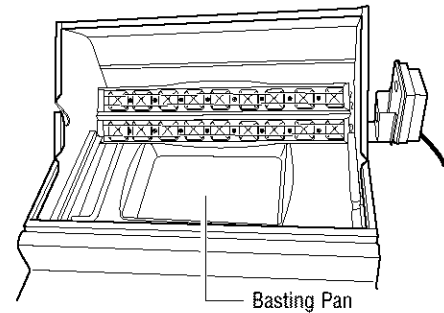

24" model rotisserie

Basting pan

The location of the burner allows the placement of the rotisserie basting pan (included) beneath the food to collect juices and drippings for basting and gravy.

To flavor the contents of the basting pan, you can add herbs, onion, garlic or spices. Hams are especially good with the addition of pineapple slices and brown sugar to the basting pan.

To load the skewer

1. To load the skewer begin with the handle in place and slide one of the meat holders, with the prongs facing away from the handle, onto the skewer.
2. Push the skewer through the center of the food, then slide the second meat holder with the prongs toward the food, onto the skewer.
3. Center the food on the skewer. Push the meat holders firmly together. (Some models have grooves on the skewer to indicate the burner position. Use them to position the meat holders.) When cooking foods such as multiple chickens, always place the thickest portion of the food nearer the center of the skewer.
4. Tighten the wing nuts with pliers. It may be necessary to wrap the food with butcher's string to secure any loose portions. Never use nylon or plastic string.
5. Once the food is secure, insert the skewer into the motor. If needed, remove the grill racks. Place the basting pan beneath the food. It is normal for the skewer to flex when larger cuts of meat are being cooked.
6. Use the motor switch (on some models) to turn the rotisserie motor on or off.

To light the rotisserie burner

(on some models)

Open the lid. Push the control knob to the LITE position.

Press the safety valve button, hold in, and begin turning the rotary ignitor button located next to the control knob. It may be necessary to turn the ignitor knob several times until the burner lights. You will hear a snapping sound. At the same time, a spark will be provided at the safety probe. Once the burner ignites, hold the safety valve button in for about 10 seconds or until the burner remains lit.

This is the only burner on the grill with a safety valve. Once lit, turn the control knob to the desired setting.

If the burner does not light within 4 seconds, release the safety valve button and turn the control knob to OFF.

Match lighting a rotisserie burner. On some models, a match stick extension rod is provided inside the grill drip pan. Insert an UNLIT match stick securely into the clip end of the extension rod. To match light the rotisserie burner, open the lid then push and turn the rotisserie control knob to the LITE position. Light the match and hold it directly in front of the ceramic rotisserie burner tile adjacent to the spark ignitor. Press and hold in the safety valve button. Once the burner ignites, continue to hold the safety valve button in for about 10 seconds or until the burner remains lit. Once lit, turn the control knob to the desired setting. If the burner does not light within 4 seconds, release the safety valve button and turn the control knob to OFF. Wait 5 minutes, for any accumulated gas to dissipate, before trying again. If the burner will not light after several attempts, see the Problem Solver in the back of this guide.

Wait 5 minutes before relighting a hot rotisserie burner.

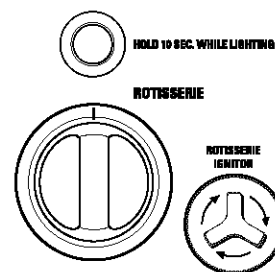

NOTE: The location of the rotisserie burner makes it susceptible to strong wind conditions, more so than the protected grill burners. For this reason you should avoid utilizing the rotisserie burner during windy conditions. As an added precaution we've equipped the burner with an automatic safety valve which will not allow gas to flow to the rotisserie burner unless the following conditions are present with the knob on:

1. The safety valve button is pressed.
2. The safety probe is sufficiently heated to open the valve.

Cooking times

To help you in planning your rotisserie cooking, these are representative cooking times. Refer to a cookbook for suggested marinade and menu ideas.

Food	Setting	Approx. Time
Large chicken thighs/kabobs	Med. High	40 minutes
Rack of spare ribs	High	50 minutes
12–15 lb. Turkey	High	3 hours
10 lb. Pork roast	High	1½–2 hours
8–12 Lamb chops	Med. High	20–25 minutes

The Smoker System

Stainless Steel Outdoor Cooking Center

The smoke flavor tray

(on some models)

For the 27" models, the smoke flavor tray is located directly beneath the rotisserie burner. It is a stainless steel tray which is designed to hold wood chips or herbs for adding a smoke flavor to foods.

For the 36" and 48" models, the smoke flavor tray is located above a 5,000 BTU burner. The burner is controlled by a precision brass valve which is capable of being turned down to very low heat levels. The smoker system may be used alone for low temperature roasting and smoking or in conjunction with any combination of other burners.

The tray may also be filled with water to produce steam. Whether smoking or steaming, the lid should remain closed as much as possible to maximize the effect.

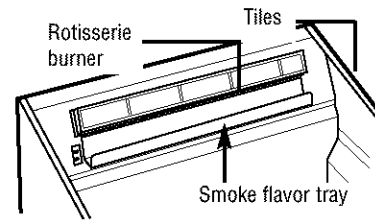

Because of the location of the smoke flavor tray on 27" models, the rotisserie burner acts as the burner for the smoke flavor tray.

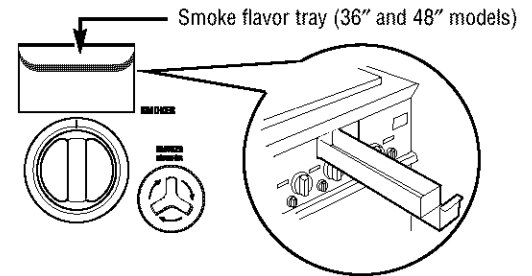

Wood chips

There are many wood chips available for purchase and selection is based on personal taste. The most common wood chips used are mesquite or hickory. Mesquite has a sweeter taste and is commonly used with poultry and seafood. Hickory is best suited for red meats. Use of oak, cherry, maple, aspen or apple is also common while aromatic herbs like sage, bay leaves, thyme or basil may also be of use.

Always soak the chips in water prior to putting them into the tray. In the beginning you may want to use the HI position to start the chips smoking, then reduce the heat to a lower level to prevent them from drying out and flaming.

If the wood chips do flame up, add a small amount of water to extinguish the flame. This should be done carefully through the top of the grill area, or by pulling the tray out slightly.

To avoid steam burns, use caution when adding water to a hot tray. Never completely remove a hot tray.

During extended roasting periods, it is normal to add fresh wood chips to the tray several times.

To minimize the possibility of burns, do not remove the smoker tray when hot.

To light the smoker burner

(on some models)

Open the lid and remove the smoker tray. Locate the burner visually by looking through the cut-out in the valve panel. Push and turn the control knob to the LITE position and immediately turn the smoker rotary ignitor knob (for 36" or 48" cooking centers) or the rotisserie rotary ignitor knob (for the 27" cooking centers) until the burner is lit or 4 seconds pass. If the burner doesn't ignite, wait 5 minutes for any accumulated gas to dissipate, then try again.

If the burner will not light after several attempts, the burner can be match lit. On some models, a match stick extension rod is provided inside the grill drip pan. Insert an UNLIT match stick securely into the clip end of the extension rod. To match light the smoker tray burner, first slide the tray out to its fully extended position. Keep your face as far away from the grill as possible, light the match stick and, holding the end of the rod, pass the flame of the lit match through the grill rack, past the radiant tray directly in front of a burner port. Push and turn the control knob to the LITE position. If the burner does not light after 4 seconds, turn the knob to OFF. Wait 5 minutes, for any accumulated gas to dissipate, before trying to light the burner again. If the burner will not light after several attempts, see the Problem Solver in the back of this guide.

Once lit, fill the smoker tray and replace.

When using the smoker system in conjunction with the optional infrared rotisserie burner, you'll find it helpful to use the low setting of the smoker burner to minimize the heat rising up to the rotisserie basting pan. Staggering the meat away from the smoker burner also helps.

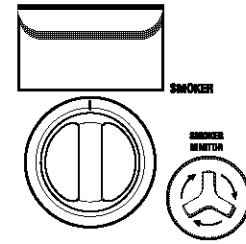

On 36" and 48" cooking centers

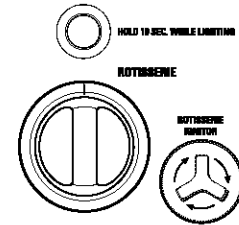

On 27" cooking centers

Grill components

Do not clean any of the grill components in a self-cleaning oven or in a dishwasher.

Do not use a steel wool pad to clean any of the grill components.

Grill components should be cleaned by hand using warm sudsy water and a Scotch Brite® pad. A brass bristle grill brush may also be used.

Grill rack(s)

The easiest way to clean the grill is immediately after cooking is completed and after turning off the flame. Wear a barbecue mitt to protect your hand from the heat and steam. Dip a brass bristle barbecue brush in tap water and scrub the hot grill. Drip the brush frequently in the bowl of water. Steam, created as water contacts the hot grill, assists the cleaning process by softening any food particles. The food particles will fall onto the hot lava rocks or ceramic briquettes and burn or fall into the drip tray (on some models). If the grill is allowed to cool before cleaning, cleaning will be more difficult.

For harder baked-on food particles, remove the grill rack and soak for about one hour in warm water. Lightly scrub with a Scotch Brite® pad.

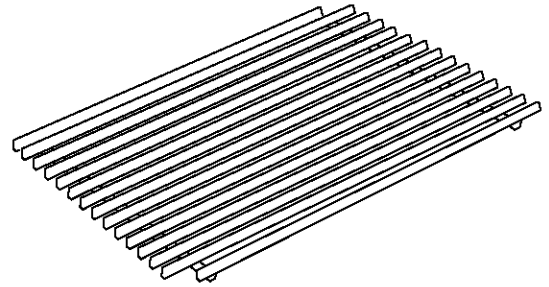

Drip trays *(on some models)*

The full width drip trays will collect grease from the grill section, as well as boilovers and spills from the range-top burners (on some models).

Allow the pan and its contents to cool before attempting to clean. Clean the grease from the pan often to avoid the possibility of a grease fire.

Lava rocks *(on some models)*

It is not necessary to remove the lava rocks for cleaning. They burn themselves clean during the next cooking operation. Periodically the rocks need to be turned over for a thorough cleaning. How often you use the grill and the amount and type of food cooked will determine when it is necessary to turn the lava rocks.

If grease can be seen on the top of the rocks, or if you get a lot of flare-ups during cooking, the rocks need to be turned over and heated on HIGH for about 30 minutes, longer for heavy soil.

Ceramic briquettes *(on some models)*

The layer of ceramic briquettes, under the grill rack(s), will last for many years with proper care.

Burned-on food particles and ash can be emptied off the stainless steel radiant trays when cool by shaking over a waste receptacle.

After emptying the ash from the trays, replace them with the small tray in the back and the large tray in the front. Make sure the briquettes do not cover the holes in the tray.

Chipping or cracking of the briquettes may occur as they may get brittle with age, depending on the frequency of use. This is normal and does not affect the performance.

Do not replace the stainless steel radiant trays with alternates. Should the ceramic briquettes ever need to be replaced, purchase them locally, wherever outdoor cooking centers are sold.

Gourmet Radiant™ Trays

(on some models)

The Gourmet Radiant™ Trays are made from 304 stainless steel and can be removed from the grill when cool.

Clean by hand using warm sudsy water and a Scotch Brite® pad. A brass bristle grill brush may also be used.

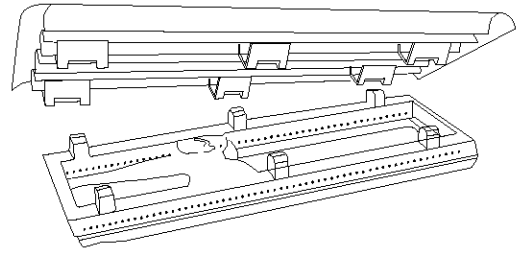

For 27", 36", and 48" models only

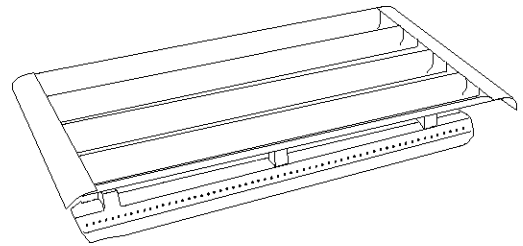

Make sure that the Gourmet Radiant™ Tray sits directly on the burner studs as shown in illustrations above.

Burner grates

(on some models)

The range-top burner grates are porcelain enamel over cast iron for durability. To avoid burns do not clean a hot grate. They may be wiped while in place with hot, soapy water, rinsed and wiped dry. Never immerse a hot grate in water.

Due to rapid temperature changes, the porcelain may pop off the edges of the grates. Do not be concerned as the base metal, cast iron, soon darkens to blend with the porcelain enamel. Use care when wiping areas where the enamel has popped off. The edges may be sharp.

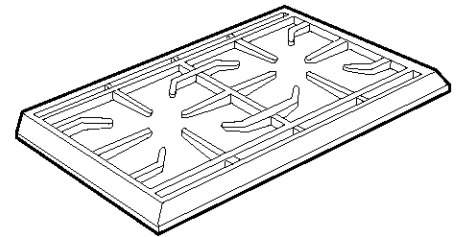

If you remove the grates for cleaning, care should be taken in lifting them. They are very heavy. Place the grates on a protected surface.

Replacing a rotary igniter

Before replacing an igniter, perform this simple test.

1. Remove the drip tray (on some models).
2. From underneath the valve panel, look upwards and locate the end of the igniter wire, where it is connected. Disconnect the wire and place the metal blade of a screwdriver about 1/8" from the terminal of the rotary igniter.
3. Turn the igniter knob. If the igniter is good, a spark will jump across to the screwdriver. If there is no spark, replace the igniter.

If there is a spark, examine the wire of the electrode for cracks and cuts. Also examine the electrode for grease and debris or see if the electrode tip is bent. Is the tip sparking to the top of the electrode bracket?

The rotary igniter may be replaced from the front by removing the drip pan (on some models) and reaching behind the valve panel to unplug the igniter wire. Remove the igniter knob and the two mounting screws. (Reverse the procedure to replace.) If removing the valve panel is necessary, begin by removing all the control knobs, then remove the 4 corner screws of the valve panel.

Spider and insect warning

Spiders and insects can nest in the burners or orifices of this or any outdoor gas appliance. The presence of spiders, spider webs or other insects can cause the gas to flow from the front of the burner. This is a very dangerous condition which can cause a fire to occur behind the valve panel, damaging the cooking center and making it unsafe for use.

You should inspect the burners at least once a year or immediately if any of the following conditions occur:

1. The smell of gas in conjunction with the burner flames appearing yellow.
2. The grill or range-top burners do not reach temperature.
3. The grill or range-top burners heat unevenly.
4. The burners make popping noises.

If blockage exists, clean the burners immediately.

Burner removal

(on some models)

Ensure the gas supply is off, the knobs are in the OFF position and all surfaces are cool before removing a burner.

The grill and range-top burners are cast iron coated with porcelain enamel. Occasionally it will be necessary to remove surface rust to ensure proper performance. Frequency of cleaning will depend on the climate and location and how often you use the cooking center. The walls of the burners are thick so they can withstand many years of use.

To remove the grill burner(s), first remove the grill rack(s). Then, depending on your model, lift out the Gourmet Radiant™ Trays or the stainless steel radiant trays with lava rocks or ceramic briquette still on them. Remove wire shipping ties if present. Pull the burner up and slightly to the rear of the unit so the burner head comes off the brass orifice at the front. Angle the burner sideways and remove. (24" models have two grill burners.)

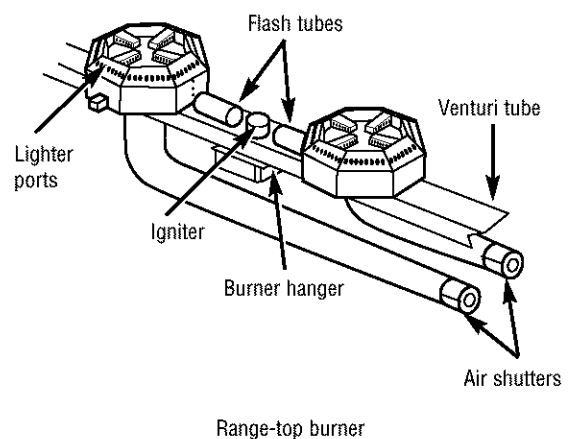

Burner removal

(on some models)

(continued)

To remove the range-top burners (on some models), remove the top grates. Lift out aeration pan from around the burners. Lift and remove the front and rear range-top burners.

The smoker burner (on some models) can be removed and cleaned by unplugging the igniter wire and lifting out the burner.

When reinstalling burners, make sure all burners are in the correct position. Burners should rest flat over the anti-flip bracket (on some models) with stubs on top and flat side down. Also, check to make sure all grill burners are level and securely seated in grill box.

To reassemble the burners, replace the burner by sliding the air shutters over the brass orifice, centering it in the hole. **It is extremely important to center the burner on the orifice properly.** (See the Installation Instructions for detailed directions.)

Be careful not to upset the air shutters' original position (unless readjusting). Lower the rear of the burner into the cutouts on the support channel and make sure the locating hole in the burner end is seated over the pin in the burner box. **Make sure all burners are level and do not rock.**

On 24" models, to double check if the two burners are properly seated over the brass orifices, you can visually inspect them.

1. Remove the two outer control knobs.
2. Remove the two screws underneath the control knobs and the two screws underneath the control panel.
3. Rotate the control panel forward. (Do not remove it.)
4. Shine a flashlight in the gap to make sure the burners are over the brass orifices. Replace screws and knobs.

Replace the radiant tray with lava rocks or the Gourmet Radiant™ trays so that the slots in the corners of the tray align with the projections on the top of the burner. (On 24" models the stainless steel radiant trays sit level on the side supports.) Make sure that it sits level and does not rock.

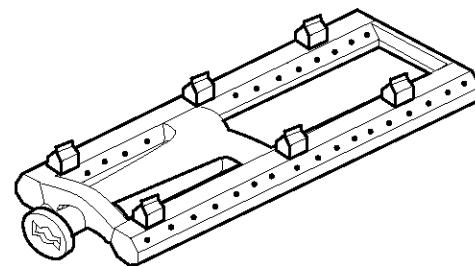

Grill burner for 27", 36" and 48" models

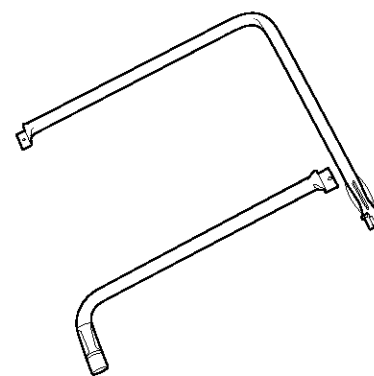
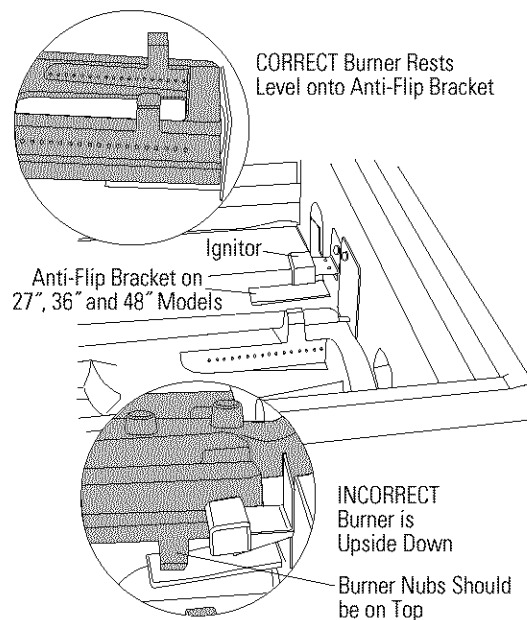

Grill burners for 24" model

Light all of the burners and check for proper flame characteristics. (Do not attempt to light the burners prior to replacing radiant trays, grills and aeration pans.) If adjustments are necessary, refer to the Installation Instructions.

Care and Cleaning

Stainless Steel Outdoor Cooking Center

Stainless steel surfaces

(on some models)

Do not use a steel wool pad; it will scratch the stainless steel surface.

Clean with hot soapy water. Rinse and dry.

If food soil remains, try a general kitchen cleaner, such as Fantastik®, Simple Green® or Formula 409®.

For hard to clean soil, use a standard stainless steel cleaner such as Bon-Ami® or Cameo®. Soils can also be soaked several hours with wet

towels. Apply cleaner with a damp sponge, rinse thoroughly and dry. Always scrub lightly in the direction of the grain.

After cleaning, use a stainless steel polish such as Stainless Steel Magic®, Revere Copper and Stainless Steel Cleaner®, or Wenzol All Purpose Metal Polish®. Follow the product instructions for cleaning the stainless steel surface.

Rotisserie

Keep the rotisserie motor electric cord away from the heated surface of the grill. When not in use remove and store the motor in a dry location.

Clean the skewer in warm sudsy water.

Burner cleaning

Clean the exterior of the burner(s) with a wire brush.

Be sure burner ports are clear and free from debris. Clear any clogged ports with a straightened paper clip. Never use a wooden toothpick as it may break off and clog the port. Never enlarge the burner ports. Shake out any debris through the air shutter.

Use a flashlight to inspect the burner inlet to ensure it is not blocked. If obstructions can be seen, use a metal wire coat hanger that has been straightened out to clear them.

NOTE: To ensure warranty coverage and proper performance of the grill and range-top burners, monthly inspection and cleaning of all the grill and range-top burner orifices is recommended.

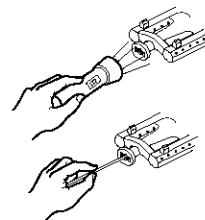

Grill burner for 27", 36" and 48" models

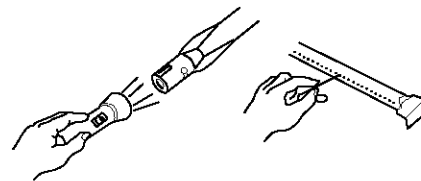

Grill burners for 24" model

Orifice cleaning

With the burner(s) removed, remove the orifice and shine a flashlight through the opening to ensure there is no blockage.

Use a needle to clear any debris. Be extremely careful not to enlarge the hole or break off the needle.

Control panel and knobs

Clean up spatters with a damp cloth. Remove heavier soil with warm, soapy water.

Do not use abrasives of any kind on the control panel.

The control knobs may be removed for easier cleaning. To remove a knob, pull it straight off the stem. Wash the knobs in soap and water but do not soak.

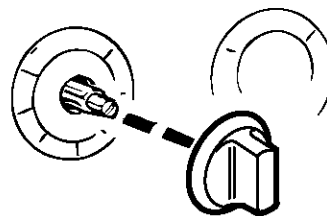

*Questions?
Use this
problem
solver!*

PROBLEM	POSSIBLE CAUSE
GRILL WON'T LIGHT WHEN THE ROTARY IGNITER IS TURNED	<ul style="list-style-type: none"> · Check to see if other burners on the unit operate. · Remove the grill rack and the stainless steel radiant tray, and watch the igniter tip. You should see a spark jump from the tip of the igniter when the knob is turned. If there is no spark check to ensure there is gas supplied to the unit. · Use a match to light the burner. (See the "To light the grill" section). · Visually check the electrode and wire while turning the igniter. The only place a spark should appear is at the electrode tip. If the electrode or wire leaks voltage, remove and replace. · Purge the gas line of any air. · Check the orifice for blockage. · Inspect the igniter tip to make sure it is clean and free from debris. Clean the area. Readjust for 1/8" gap.
BURNER FLAME IS YELLOW OR ORANGE IN CONJUNCTION WITH THE ODOR OF GAS	<ul style="list-style-type: none"> · Check the burner inlet for obstructions. · Check the air shutter for proper adjustment. (See the "Installation Instructions"). · Placement of the cooking center is important for proper burner operation. Do not place the cooking center in a dusty area.
LOW HEAT WITH CONTROL KNOB IN THE HI POSITION	<ul style="list-style-type: none"> · Inspect the fuel hose to ensure it is not bent or kinked. · Adequate gas supply may not be available. Check to make sure there is gas in the LP tank (on some models). · If it is only one burner that appears low, the burner or burner orifice may need cleaning. · The air shutter may need adjustment. · Preheat the grill for 15 minutes with the lid closed.
ROTISSERIE BURNER WON'T LIGHT (on some models)	<ul style="list-style-type: none"> · Check for a spark at the igniter. · Use a match to light the burner.
OPTIONAL ROTISSERIE LIGHTS BUT WILL NOT HOLD FLAME ONCE BUTTON IS RELEASED (on some models)	<ul style="list-style-type: none"> · Readjust the thermocouple so that it is not bent or kinked, but lies flat against the burner. · Hold the safety valve button in until the burner remains lit.
THE GRILL BURNER WILL NOT SIT LEVEL INSIDE THE GRILL BOX	<ul style="list-style-type: none"> · The burner may be upside down. Rotate the burner 180° and reinstall. Make sure it is secure and level.



**Consumer Product
Ownership Registration**
Important Mail Today

GE Appliances



Place
1st Class
Letter
Stamp
Here

General Electric Company
Warranty Registration Department
P.O. Box 32150
Louisville, KY 40232-2150

YOUR MONOGRAM OUTDOOR COOKING CENTER WARRANTY
Staple sales slip or cancelled check here. Proof of original purchase date is needed to obtain service under warranty.

WHAT IS COVERED

FULL ONE-YEAR WARRANTY

For one year from date of original purchase, we will provide, free of charge, parts and service labor in your home to repair or replace **any part of the cooking center** that fails because of a manufacturing defect.

LIMITED FIVE-YEAR WARRANTY

For five years from the date of original purchase, we will provide, free of charge, replacement **cast iron burners, stainless steel radiant tray, upper and lower heat shields, grill racks and drip pans** if they fail in normal use. You pay for the service trip to your home and all service labor charges.

LIMITED LIFETIME BURNER WARRANTY

For the life of the product, for the original owner, we will provide, free of charge, replacement **cast iron burners** if they deteriorate in normal use to the point of failure.

This warranty is extended to the original purchaser and any succeeding owner for products purchased for ordinary home use in Canada.

All warranty service will be provided by our Factory Service Centers or by our authorized Customer Care® servicers during normal working hours.

Should your appliance need service, during warranty period or beyond, call 1.888.880.3030.

WHAT IS NOT COVERED

- Service trips to your home to teach you how to use the product.
- Failure of the product if it is used for other than its intended purpose or used commercially.
- Improper installation.
- **Read your Use and Care material.**
If you then have any questions about operating the product, please contact your dealer or our Consumer Affairs office at the address below, or call, toll free: **1.888.880.3030**
- If you have an installation problem, contact your dealer or installer. You are responsible for providing adequate electrical, gas, exhausting and other connecting facilities as described in the Installation Instructions provided with the product.
- Replacement of rotary igniters.
- Chipping of porcelain enamel grates or burners.
- Replacement of house fuses or resetting of circuit breakers.
- Damage to the product caused by accident, fire, floods or acts of God.

WARRANTOR IS NOT RESPONSIBLE FOR CONSEQUENTIAL DAMAGES.

Some provinces do not allow the exclusion or limitation of incidental or consequential damages, so the above limitation or exclusion may not apply to you. This warranty gives you specific legal rights, and you may also have other rights which vary from province to province. To know what your legal rights are in your province, consult your local or provincial consumer affairs office.

Warrantor: Camco, Inc. If further help is needed concerning this warranty, write: Manager—Consumer Relations, Inc., 1 Factory Lane, Suite 310, Moncton, N.B. E1C 9M3.

Warranty for customers in the USA

Stainless Steel Outdoor Cooking Center

YOUR MONOGRAM OUTDOOR COOKING CENTER WARRANTY *Staple sales slip or cancelled check here. Proof of original purchase date is needed to obtain service under warranty.*

WHAT IS COVERED

FULL ONE-YEAR WARRANTY

For one year from date of original purchase, we will provide, free of charge, parts and service labor in your home to repair or replace **any part of the cooking center** that fails because of a manufacturing defect.

LIMITED FIVE-YEAR WARRANTY

For five years from the date of original purchase, we will provide, free of charge, replacement **cast iron burners, stainless steel radiant tray, upper and lower heat shields, grill racks and drip pans** if they fail in normal use. You pay for the service trip to your home and all service labor charges.

LIMITED LIFETIME BURNER WARRANTY

For the life of the product, for the original owner, we will provide, free of charge, replacement **cast iron burners** if they deteriorate in normal use to the point of failure.

This warranty is extended to the original purchaser and any succeeding owner for products purchased for ordinary home use in the 48 mainland states, Hawaii and Washington, D.C. In Alaska the warranty is the same except that it is LIMITED because you must pay to ship the product to the service shop or for the service technician's travel costs to your home.

All warranty service will be provided by our Factory Service Centers or by our authorized Customer Care® servicers during normal working hours.

Should your appliance need service, during warranty period or beyond, call 800-444-1845.

WHAT IS NOT COVERED

- Service trips to your home to teach you how to use the product.
 - **Read your Use and Care material.**
If you then have any questions about operating the product, please contact your dealer or our Consumer Affairs office at the address below, or call, toll free:
GE Answer Center®
800.626.2000
consumer information service
 - Replacement of rotary igniters.
 - Chipping of porcelain enamel grates or burners.
 - Replacement of house fuses or resetting of circuit breakers.
 - Damage to the product caused by accident, fire, floods or acts of God.
 - Failure of the product if it is used for other than its intended purpose or used commercially.
 - Improper installation.
If you have an installation problem, contact your dealer or installer. You are responsible for providing adequate electrical, gas, exhausting and other connecting facilities as described in the Installation Instructions provided with the product.
- WARRANTOR IS NOT RESPONSIBLE FOR CONSEQUENTIAL DAMAGES.**

Some states do not allow the exclusion or limitation of incidental or consequential damages, so the above limitation or exclusion may not apply to you. This warranty gives you specific legal rights, and you may also have other rights which vary from state to state.

To know what your legal rights are in your state, consult your local or state consumer affairs office or your state's Attorney General.

Warrantor: General Electric Company. If further help is needed concerning this warranty, write: Manager—Consumer Affairs, GE Appliances, Louisville, KY 40225



ZGG24L20	ZGG36N20	ZGG36N31	ZGG48N40
ZGG27L20	ZGG36L21	ZGG48L30	ZGG48L42
ZGG27N20	ZGG36N21	ZGG48N30	ZGG48N42
ZGG27L21	ZGG36L30	ZGG48L31	
ZGG27N21	ZGG36N30	ZGG48N31	
ZGG36L20	ZGG36L31	ZGG48L40	

10965
Part No. 164D3333P192
Pub No. 49-8965-3

03-00 JR

Printed in the United States

