

CRAFTSMAN®

120 V.A.C. 12 AMP. 60 Hz.
Double Insulated
20" Clearing Width
ELECTRIC SNOW THROWER

MODEL NO.
536.882091

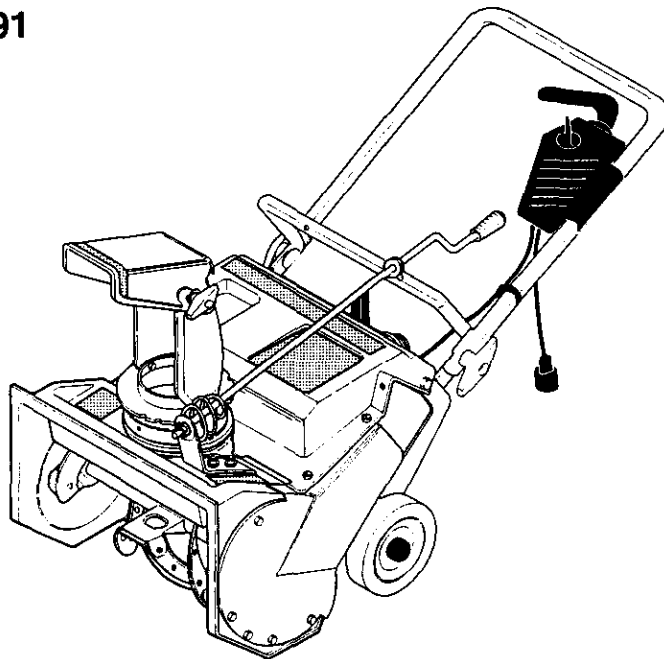

Caution:
Read and follow all Safety
Rules and Operating
Instructions before first use
of this product.

LISTED
SNOW THROWER
NO. 894Y

SEARS, ROEBUCK AND CO., Hoffman Estates, IL 60179 U.S.A.
F001021M 08/30/99

SAFETY

ASSEMBLY

OPERATION

MAINTENANCE

PARTS LIST

ESPAÑOL

TABLE OF CONTENTS

Table of Contents	2	Service and Adjustments	9-10
Warranty	2	Storage	10
Safety Rules	2-4	Troubleshooting	11
Contents of Shipping Carton	4	Repair Parts	12-20
Assembly	4-5	Spanish (Español)	21-32
Operation	5-8	Parts Ordering/Service	Back Cover
Maintenance	8		

WARRANTY STATEMENT

LIMITED ONE-YEAR WARRANTY ON CRAFTSMAN SNOW THROWER

For one year from the date of purchase, when this Craftsman Snow Thrower is maintained, lubricated, and tuned up according to the operating and maintenance instructions in the owner's manual, Craftsman will repair, free of charge, any defect in material or workmanship.

If this Craftsman Snow Thrower is used for commercial or rental purposes, this warranty applies for only 90 days from the date of purchase.

This warranty does not cover the following:

- Items which become worn during normal use, such as drive belts and shear pins.
- Repairs necessary because of operator abuse or negligence, including bent drive shafts and the failure to maintain the equipment according to the instructions contained in the owner's manual.

WARRANTY SERVICE IS AVAILABLE BY RETURNING THE CRAFTSMAN SNOW THROWER TO THE NEAREST CRAFTSMAN SERVICE CENTER/DEPARTMENT IN THE UNITED STATES. THIS WARRANTY APPLIES ONLY WHILE THIS PRODUCT IS IN USE IN THE UNITED STATES.

This warranty gives you specific legal rights, and you may also have other rights which may vary from state to state.

Sears, Roebuck and Co., D817WA, Hoffman Estates, IL 60179



SAFETY RULES



Look for this symbol to point out important safety precautions. It means— ATTENTION!!! Become alert!!! Your safety is involved.

CAUTION: Always disconnect power cord to prevent accidental starting when setting-up, transporting, adjusting or making repairs.

IMPORTANT: Safety standards require operator presence controls to minimize the risk of injury. Your snow thrower is equipped with such controls. Do not attempt to defeat the function of the operator presence control under any circumstances.

BEFORE USE

- Read the owner's manual carefully. Be thoroughly familiar with the controls and the proper use of the snow thrower. Know how to stop the snow thrower and disengage the controls quickly.
- Do not operate the snow thrower without wearing adequate outer garments. Wear footwear that will improve footing on slippery surfaces.
- Keep the area of operation clear of all persons, particularly small children and pets.
- Thoroughly inspect the area where the snow

thrower is to be used and remove all doormats, sleds, boards, wires, and other foreign objects.

- Use extension cords and receptacles as specified by the manufacturer for all snow throwers with electric drive motors or with factory-installed or optional starting motors.
- Use only attachments and accessories approved by the manufacturer of the snow thrower. No attachments are recommended for use with this unit. Any such use might increase the risk of injury to the operator.
- Never operate the snow thrower without good visibility or light. Always be sure of your footing, and keep a firm hold on the handles. Walk; never run.
- This snow thrower is for use on sidewalks, driveways, and other ground level surfaces. **CAUTION:** should be exercised while using on steep sloping surfaces. **DO NOT USE SNOW THROWER ON SURFACES ABOVE GROUND LEVEL** such as roofs of residences, garages, porches or other such structures or buildings.

- Check shear bolts and other bolts frequently for proper tightness to be sure the snow thrower is in safe working condition.
- Let engine and snow thrower adjust to outdoor temperatures before starting to clear snow.

⚠ WARNING: The motor is equipped with a protector that will disconnect power to the motor temporarily if the snow thrower is overworked, and will automatically reset as the motor cools. If the motor stops, release the control bar, disconnect the extension cord and allow the motor to cool 5 minutes before continuing operation.

OPERATING SAFETY

- Do not operate this machine if you are taking drugs or other medication which can cause drowsiness or affect your ability to operate this machine.
- Do not use this machine if you are mentally or physically unable to operate this machine safely.
- Never allow children or young teenagers to operate the snow thrower. Keep them away while it is operating. Never allow adults to operate the snow thrower without proper instruction.
- Always wear safety glasses or eye shields during operation or while performing an adjustment or repair to protect your eyes from foreign objects that may be thrown from the snow thrower.
- Always dress properly. Do not wear loose clothing or jewelry. They can be caught in moving parts.
- Do not put hands or feet near or under rotating parts. Keep clear of the discharge opening at all times.
- Exercise extreme caution when operating on or crossing gravel drives, walks, or roads to avoid slipping or falling, especially when operating in reverse or backing up. Stay alert for hidden hazards or traffic.
- Do not clear snow across the face of slopes. Exercise caution when changing direction on slopes. Do not attempt to clear steep slopes.
- Never operate the snow thrower without proper guards, plates, or other safety protective devices in place.
- Operation of the snow thrower in the hand hold position is unsafe, except in accordance with the special instructions for such use provided in this manual.
- Never operate the snow thrower near glass enclosures, automobiles, window wells, drop-offs, and the like without proper adjustment of the snow discharge angle. Keep children and pets away.
- Never operate the snow thrower on graveled surface unless the snow thrower is adjusted for such a surface in accordance with the this manual. See Operating Tips in the Operation section of this manual.

- Never operate the snow thrower at high transport speeds on slippery surfaces. Look behind and use care when backing.
- Never direct discharge at bystanders or allow anyone in front of the snow thrower.
- Take all possible precautions when leaving the snow thrower unattended. Disengage the auger/impeller, and remove key.
- To prevent accidental starting do not carry plugged in snow thrower with finger on switch. Be sure switch is off when plugging in.
- If cord is damaged in any manner while plugged in, pull extension cord from wall receptacle.
- Do not abuse cord. Never carry snow thrower by cord or yank it to disconnect from receptacle. Keep cord from heat, oil, and sharp edges.
- Do not overload the machine capacity by attempting to clear snow at too fast a rate.
- Do not force snow thrower it will perform better and safer at the rate for which it was designed.
- Do not overreach, keep proper footing and balance at all times.

WARNING: To prevent electric shock use a U.L. listed two conductor extension cord suitable for outdoor use in cold weather. Extension cord should be no longer than 100 feet. See chart on page 6 for recommended extension cords.

- To prevent accidental disconnection of extension cord from control switch during operation, loop extension cord through strain relief clip on control switch as shown in first figure on page 7.

SAFE STORAGE

- Always refer to the owner's manual instructions for important details if the snow thrower is to be stored for an extended period.
- Store snow thrower indoors when not in use, snow throwers should be stored indoors in dry, locked-up place out of reach of children.

REPAIR/ADJUSTMENTS SAFETY

- After striking a foreign object, stop the engine (motor), disconnect the cord on electric motors, thoroughly inspect the snow thoroughly inspect the snow thrower for any damage, and repair the damage before restarting and operating the snow thrower.
- If snow thrower should start to vibrate abnormally, stop engine (motor) and check immediately for the cause. Vibration is generally a warning of trouble.
- Stop the engine (motor) whenever you leave the operating position. Also, disconnect the power cord before unclogging the auger/impeller housing or discharge chute, and when making any repairs, adjustments, or inspections to prevent accidental starting.
- When cleaning, repairing, or inspecting, make certain the auger/impeller and all moving parts have stopped. Disconnect the power cord for service.

- Never attempt to make any adjustments while the engine (motor) is running (except when specifically recommended by the manufacturer).
- Maintain or replace safety and instruction labels, as necessary.
- When servicing use only identical replacement parts. Replace or repair damaged cords.
- Maintain snow throwers with care. Follow instructions and changing accessories.
- Run the snow thrower a few minutes after throwing snow to prevent freeze-up of the auger/impeller.

⚠ WARNING: Look for this symbol to point out important safety precautions. It means---Attention!!! Become alert!!! Your safety is involved.

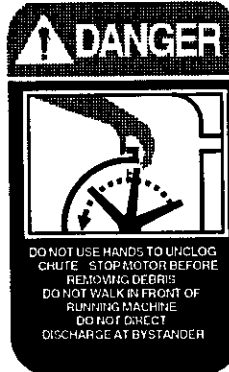

Contents of Parts Bag (not shown actual size)

- 1 - Owner's Manual
- 1 - Parts Bag
- 1 - Warranty Card



1 - Key



1 - Plastic Tie

ASSEMBLY

⚠ CAUTION: Always wear safety glasses or eye shields while assembling snow thrower.

TOOLS REQUIRED FOR ASSEMBLY

- 1 - Knife to cut carton
- 1 - Pliers

The figure below shows the snow thrower completely assembled.

References to the right or left hand side of the snow thrower are from the viewpoint of the operator's position behind the unit.

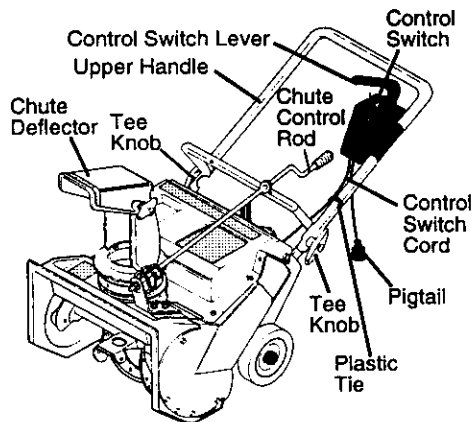

TO REMOVE SNOW THROWER FROM CARTON

- Remove the inserts positioned around the unit and the packing material.

- Cut down all four corners of the carton and lay the panels flat.
- Pull snow thrower out of the carton.

TO ASSEMBLE THE HANDLE

- Remove wrap on upper handle and along the side of both handles and on the chute control rod. Discard wrap.
- Loosen the tee knobs on each side of the upper handle (see left hand figure on this page).

NOTE: Make sure the control switch cord and pigtail are not caught between upper and lower handle.

- Raise the upper handle to the operating position. Hold upper handle apart to prevent scratching lower handle.
- Tighten the tee knobs. Make sure pigtail is free from the control switch cord.
- Secure control switch cord to handle using plastic tie found in plastic bag. Thread the pointed end of the tie through the square end. Pull tie tightly around the cable and handle, after securing clip excess from tie.

TO ASSEMBLE THE CHUTE CONTROL ROD

- Cut tie holding chute control rod to bracket.
- Remove plastic bag from chute control rod.
- Remove white cap, washer and cotter pin from crank.

- Remove cotter pin, flatwasher and wave washer from the worm end of chute control rod and set aside (see figure below).
- Insert the worm end of the chute control rod through the hole in the chute control rod bracket while inserting the worm into the notches in the discharge chute rotation ring (see figure below).
- Place wave washer and flatwasher onto worm end of chute control rod.
- Place cotter pin through worm end of chute control rod.
- Bend cotter pin to secure.
- Rotate the chute control rod fully clockwise and counterclockwise. The discharge chute should rotate freely without binding.

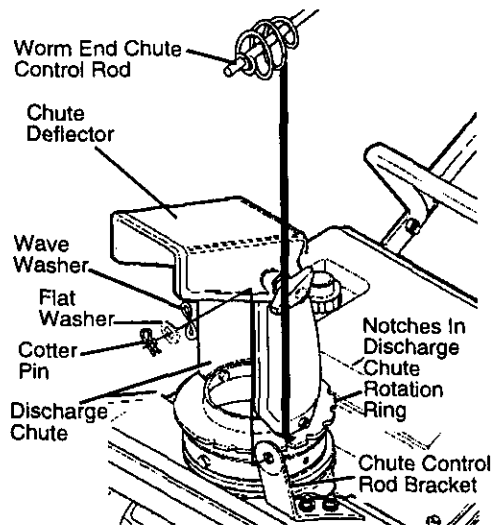

✓ CHECKLIST

Before you operate your new snow thrower, to ensure that you receive the best performance and satisfaction from this quality product, please review the following checklist:

- ✓ All assembly instructions have been completed.
- ✓ The discharge chute rotates freely.
- ✓ No remaining loose parts in carton.

While learning how to use your snow thrower, pay extra attention to the following important items:

- ✓✓ Use a U.L. listed two conductor extension cord suitable for outdoor use in cold weather.
- ✓✓ Become familiar with all controls-their location and function. Operate controls before starting motor.

OPERATION

KNOW YOUR SNOW THROWER

READ THIS OWNER'S MANUAL AND SAFETY RULES **BEFORE OPERATING YOUR SNOW THROWER**. Compare the illustrations with your SNOW THROWER to familiarize yourself with the location of various controls and adjustments. Save this manual for future reference.

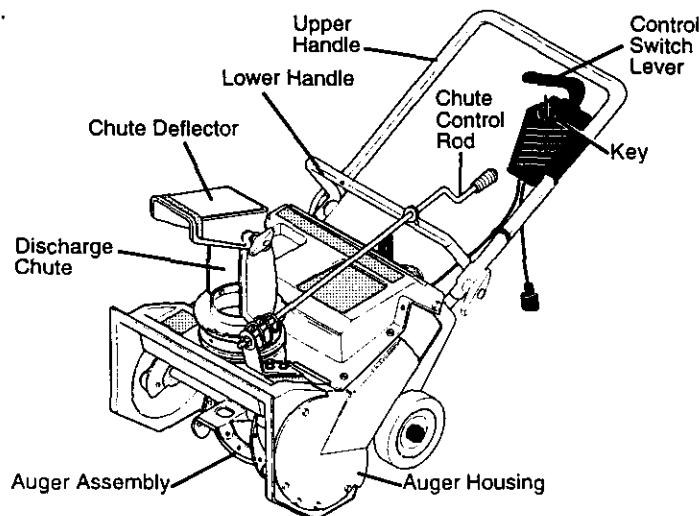

Chute Control Rod – Changes the direction of snow discharge.

Chute Deflector – Changes the distance the snow is thrown.

Discharge Chute – Changes the direction the snow is thrown.

Ignition Switch Key – Must be inserted and turned to the "UNLOCK" position to start the motor.

Control Switch Lever – Used to start and stop motor.

HOW TO USE YOUR SNOW THROWER

TO STOP YOUR SNOW THROWER

- To stop the auger or motor, release the control switch lever.

TO CONTROL SNOW DISCHARGE

- Turn the chute control rod to set the **direction** of the snow throwing.
- Loosen the wing knob on the chute deflector and move the deflector to set the **distance**. Move the deflector (Up) for more distance, (Down) for less distance. Then tighten the wing knob (See figure below).

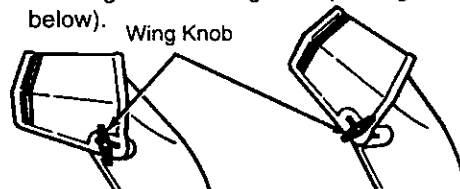

TO USE AUGER PROPEL ACTION

- Squeeze the control switch lever down against the upper handle to allow the auger to turn.
- To propel forward, raise the handle to allow the auger blades to contact the ground (See figure below).

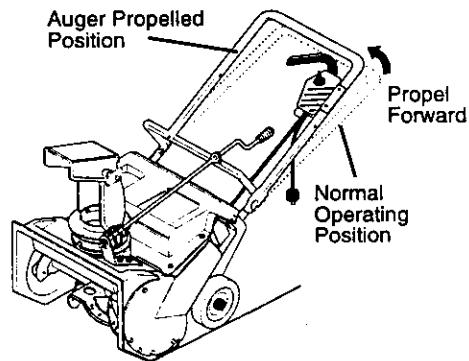

CAUTION: Read owner's manual before operating machine. Never direct discharge toward bystanders. Release the auger control bar and stop the engine

before unclogging discharge chute or auger housing and before leaving the machine.

TO OPERATE SNOW THROWER

Before starting motor be certain that you have read and understand all the instructions on the preceding pages.

WARNING: The motor is equipped with a protector that will disconnect power to the motor temporarily if the snowthrower is overworked, and will automatically reset as the motor cools. If the motor stops, release the control bar, disconnect the extension cord and allow the motor to cool 5 minutes before continuing operation.

TO START SNOW THROWER

IMPORTANT: Use a U.L. listed two conductor extension cord suitable for outdoor use in cold weather. Extension cord should be no longer than 100 feet. Extensions cords are available at Craftsman Service Centers.

RECOMMENDED EXTENSION CORDS

Ampere rating less than	Volts 120V not more than	MINIMUM GAGE FOR CORDS SETS*		
		Length of Cord in Feet 25ft	50ft	100ft
0	6	18	16	16
6	10	18	16	14
10	12	16	16	14
12	14	14	12	10

Sears stock NO. 83609 is Recommended or you may use one of the cords listed in the chart.

Always connect extension cord to control switch on snow thrower first, then connect the other end to a wall receptacle installed in accordance with local codes and inspection authorities.

To start snow thrower operation, proceed as follows:

- To prevent accidental disconnection of extension cord from control switch during operation, loop extension cord through strain relief clip on control switch as shown in the next figure.

- Snap strain relief clip down over loop of cord, see figure below. Connect extension cord to power plug on control switch.

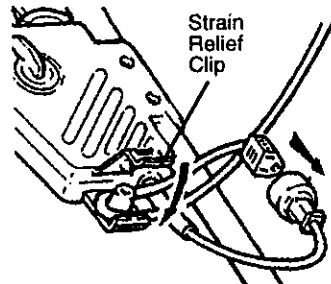

- To operate snow thrower turn key (clockwise) and hold in "unlocked" position while pulling control switch lever toward handle. Hold control switch lever and release key (see figure below).

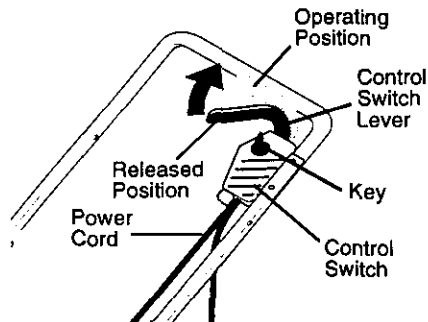

NOTE: Keep the second key (found in plastic bag) in a safe place.

- To stop snow thrower, release lever on upper handle.

TO STOP SNOW THROWER

- Release control switch lever on upper handle.
- Disconnect extension cord from wall receptacle first, then from power cord on control switch.
- Remove key when not in use.

⚠ CAUTION: If snow thrower frequently trips circuit breaker or blows fuses, Do Not replace with higher rated fuse without consulting your power company.

SNOW THROWING TIPS

- This snow thrower will propel itself forward when the handle is raised enough to cause the auger blades to contact the ground. The auger will stop when control switch lever is released.

- For most efficient snow throwing, turn the discharge chute deflector to throw snow downwind, and slightly overlap each swath. In light snow take up to a full cut and in heavy snow take less than a full cut.
- The distance snow will be discharged can be adjusted by moving the discharge chute deflector. Raise the deflector for more distance or lower the deflector for less distance.
- In windy conditions, lower the chute deflector to direct discharged snow close to the ground where it is less likely to blow into unwanted areas.
- Keep the area to be cleared free of stones, toys and other foreign objects for safety and to prevent damage to the snow thrower.
- Do not use the auger propelling feature when clearing gravel or crushed rock driveways. Move the handle down to raise the auger slightly.
- The allowable forward speed of the snow thrower is dependent on the depth and weight of the snow. Experience will establish the most effective method of using the snow thrower under different conditions.

DRY AND AVERAGE SNOW

- Snow up to eight inch depth can be removed rapidly and easily by walking at a moderate rate. For snow or drifts of a greater depth you may find it desirable to slow your pace to allow the discharge chute to dispose of the snow as rapidly as the auger receives the snow.
- Plan to have the snow discharged in the direction the wind is blowing.

⚠ CAUTION: Always stand behind snow thrower (operator's position) when starting motor.

Do Not put hands, feet, hair or loose clothing on near the discharge chute deflector or auger housing while the motor is running.

⚠ CAUTION: Objects such as gravel, rocks or other debris, if struck by the auger, may be thrown with sufficient force to cause personal injury or property damage.

WET PACKED SNOW

- Move slowly into snow of this condition. The greater the depth, the slower you should go. When it appears that the wet,

packed snow is causing the auger to slow down and the chute to clog, back off and begin a series of short jabs into the snow. These short back and forth, 4 to 6 inch, jabbing motions will "belch" the snow from the chute.

required to remove snow of this type than level snow.

SNOW BANKS AND DRIFTS

- In snow of greater depth than the unit, use the "jabbing" technique described above. Turn the discharge chute away from the snow bank. More time will be

PRODUCT SPECIFICATIONS

Rating:	120 V.A.C., 12 amps, 60Hz
Clearing Width:	20"
Clearing Height:	8"

MAINTENANCE

CUSTOMER RESPONSIBILITIES

SERVICE RECORDS Fill in dates as you complete regular service	SCHEDULE					SERVICE DATES			
	Before Each Use	After first 12 Hours	As Needed	Before Storage	Begin Each Season				
Tighten All Screws & Nuts		✓	✓						
Check Drive Belts					✓				
Lubricate Chute Control Flange				✓					

GENERAL RECOMMENDATIONS

The warranty on this snow thrower does not cover items that have been subjected to operator abuse or negligence. To receive full value from the warranty, the operator must maintain the snow thrower as instructed in this manual.

Some adjustments will need to be made periodically to properly maintain your snow thrower.

All adjustments in the Service and Adjustments section of this manual should be checked at least once each season.

SNOW THROWER AFTER FIRST USE

- Check for any loose or damaged parts after each use.
- Tighten any loose fasteners.

AFTER EACH USE

- Run the machine to clear the auger of snow.
- Remove all snow and slush from the snow thrower to prevent freezing of auger or controls.

LUBRICATION - AS REQUIRED

- Lubricate the flange on the discharge chute before storage.
- See Lubrication Chart diagram for lubrication points and type of lubricant.

LUBRICATION CHART

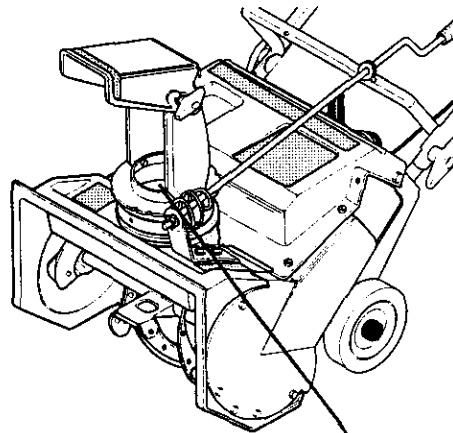

Lubricate chute control flange. Remove discharge chute and coat flange with a clinging type grease such as Lubriplate.

SERVICE AND ADJUSTMENTS

TO ADJUST THE CHUTE CRANK ASSEMBLY

If you cannot rotate the chute crank fully to the left and to the right, you need to adjust the chute crank (see figure below).

- Loosen both 1/2" nuts on the crank adjusting bracket (using 1/2" wrenches).

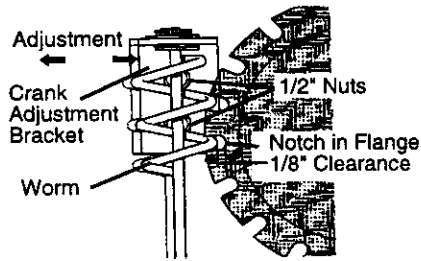

- Swivel the crank adjusting bracket to allow about 1/8" clearance between the notch in the flange and the outer diameter of the worm.
- Once this clearance is set, tighten the nuts.

TO REMOVE BELT COVER

- Remove the belt cover (see figure below) by removing the 10 screws. There are 5 screws on the front of the belt cover, 2 screws on the top cover, 3 screws on the bottom of the belt cover (the front screw on the bottom of the belt cover is shorter than the rear and top screws).
- Pull the belt cover away from the snow thrower.

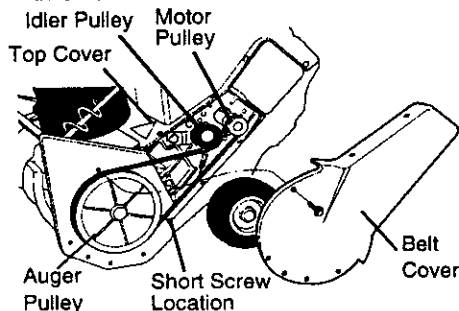

TO ADJUST THE DRIVE BELT

If the motor drive pulley and the auger drive pulley are not aligned properly, excessive belt wear will occur. To check the pulley alignment, proceed as follows:

- Remove the belt cover (see To Remove Belt Cover paragraph).
- Place a straight edge approximately 16" long across the large auger pulley, touching two points and extending to the motor pulley (see figure below). The outside of the motor pulley must be flush with the straight edge. If the pulleys are aligned, skip to the last step).

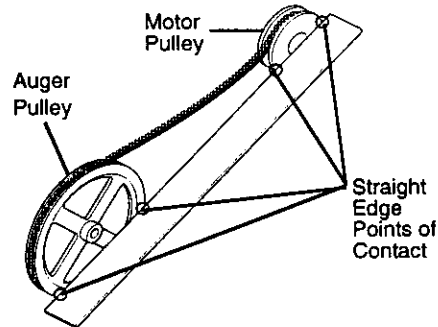

To adjust the motor pulley:

- Loosen the 2 set screws on the motor pulley.
- Slide the motor pulley in or out on the shaft until the pulley is flush with the straight edge.
- Tighten the 2 set screws on the motor pulley.
- Reinstall belt cover. Make sure the shorter screw is in the front position (see to Remove Belt Cover paragraph on this page).
- If the drive belt is damaged or worn excessively, replace it with a new belt.

NOTE: When servicing use only identical replacement parts. If extension cord is damaged, in any manner, replace or repair cord.

TO REPLACE THE DRIVE BELT

The drive belt on this unit is of special construction and must be replaced with the same type belt available at your nearest Craftsman Service Center.

- Remove the belt cover (see to Remove the Belt Cover paragraph on this page).
- Carefully lift idler pulley to release pressure on belt (see top left hand figure on page 10).
- Remove old belt.
- Replace with new belt with belt ribs down.

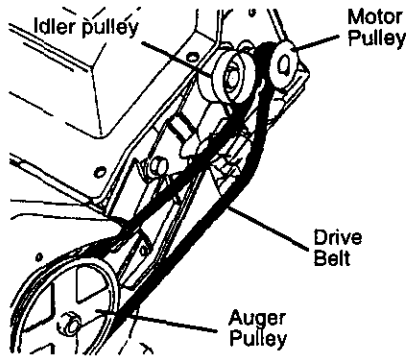

- Release idler pulley.
- Make sure the belt is seated properly.
- Check the drive belt adjustment (see to Adjust the Drive Belt paragraph on this page).
- Reinstall belt cover. Make sure the shorter screw is in the front position (see to Remove Belt Cover paragraph on page 9).

TO REPLACE THE AUGER

- Remove the belt cover (see To Remove Belt Cover paragraph on page 9) and the drive belt. See To Replace the Drive Belt paragraph on page 9.
- Remove the auger pulley (see top right hand figure) from the auger shaft (threads are left hand; turn clockwise to remove). Place a piece of wood (2x4) on the center paddle area to secure auger to keep from turning.

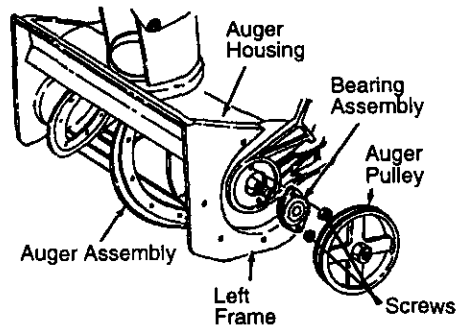

- Remove the bearing assembly from the left frame of snow thrower by removing the two nuts on the inside of housing.
- Slide the auger assembly out of the bearing assembly on the right side of the snow thrower.
- Tip the auger assembly enough to allow it to slide out of the auger housing.
- Install the new auger assembly in reverse order of removal.

NOTE: Check the drive belt adjustment before re-installing the belt cover (see To Adjust the Drive Belt paragraph on page 9).

MOTOR SERVICE

Motor repairs and adjustments should be done by technicians trained to work on snow thrower type motors. Take your snow thrower to an authorized Craftsman Service Center for repair and adjustment.

STORAGE

SNOW THROWER STORAGE

- Thoroughly clean the snow thrower.
- Lubricate all the lubrication points (see the Maintenance section, page 8).
- Be sure that all nuts, bolts and screws are securely fastened. Inspect all visible moving parts for damage, breakage and wear. Replace if necessary.
- Touch up all rusted or chipped paint surfaces; sand lightly before painting.
- Cover the bare metal parts of the blower housing and auger with rust preventative, such as a spray lubricant.

OTHER

- Store the snow thrower indoors in a clean, dry, locked-up place out of reach of children.
- Store the extension cord with the snow thrower to prevent misplacement.
- Inspect the snow thrower thoroughly for worn, loose or damaged parts. Make all necessary repairs before storing snow thrower.
- Inspect extension cord thoroughly for signs of excess wear or damage. If worn or damaged, replace with a **U.L. listed** cord suitable for outdoor use in cold weather.

NOTE: A yearly checkup or tune-up at a Craftsman Service Center is a good way of ensuring that your snow thrower will provide maximum performance for the next season.

